

# 24...28 V adjustable

# PULS

## SL5.102

- Input: AC 230V / 115V
- Output: 24V...28 V / 120 W
- Power boost up to 144 W
- High overload current, no switch-off
- Quasi-Wide-Range Input
- Robust mechanics and EMC



CE  
EMC and  
Low Volt.  
Directive

C<sup>UL</sup> US  
UL60950 E137006  
CUL/CSA-C22.2  
No. 60950

C<sup>UL</sup> US

UL508 LISTED  
IND. CONT. EQ.  
18 WM, 60°C

CB  
scheme  
IEC60950

Data sheet

### Input

Input voltage AC100-120/220-240 V (switchable), 47-63 Hz (85-132 VAC / 176-264 VAC, 210-375 VDC, see also „Output: Continuous Loading“)

Quasi-Wide-Range Input: With the switch in the 230V position the power-supply unit operates at low and moderate loads (until 3 A) at any input voltage between 95 and 264 V AC (see 'Output' below).

Note: At DC input, always leave the switch in the 230V position

Input current < 2.6 A (switch in 115V position)  
< 1.4 A (switch in 230V position)

- DCin at open output typ. 5 mA (preserves battery sources)

Inrush current typ. 15 A at 264 V AC and cold start

EN 61000-3-2 (harmonic current emissions) is fulfilled

To be fused with a 10A, B-type 'circuit-breaker' switch based on the usual thermomagn. overload sensing principle (used anyway to fuse the input lines). In addition, the unit contains an internal fuse (not accessible)

Harmonic current emissions acc. to EN 61000-3-2

Transient handling Transient resistance acc. to VDE 0160 / W2 (750 V / 1.3 ms), for all load conditions.

Hold up time > 37 ms at 196 VAC, 24 V / 5 A

### Efficiency, Reliability etc.\*

Efficiency typ. 90 % (230 VAC, 24 V / 5 A)

Losses typ. 13,3 W (230 VAC, 24 V / 5 A)

MTBF 520,000 h acc. to Siemensnorm SN 29500 (24 V/5 A, 230 VAC, T<sub>amb</sub> = +40 °C)

Life cycle (electrolytics) The unit exclusively uses longlife electrolytics, specified for +105°C (cf. 'The SilverLine', p.2).

\* For further information see data sheets „The SilverLine“, „SilverLine Family Branches“ and mechanics data sheet

### Output

Output voltage DC24 V...28 V, adjustable by (covered) front panel potentiometer; preset: 24.4 V ± 0.5 % Adjust. range guaranteed

Note: also avail. with fixed 24V output: SL5.100.

Output noise suppression Radiated EMI values below EN 61000-6-3, even when using long, unscreened output cables.

Ambient temperature range T<sub>amb</sub> Operation: -10°C...+70°C (>60°C: Derating)  
Storage: -25°C...+85°C

Continuous loading (at T <sub>amb</sub> = -10°C...+60°C, convection cooling), see also diagram overleaf. For start at T <sub>amb</sub> < 0°C and low input voltage, please contact PULS.	Switch	AC/DCin	I <sub>out</sub> @ 24V	I <sub>out</sub> @ 28V
	230V	176-264 V ≈	5 A (6 A*)	4,3 A (5,1 A*)
		95-176 V ≈	3 A	2,6 A
		210-375 V =	5 A (6 A*)	4,3 A (5,1 A*)
		150-210 V =	3 A	2,6 A
		100-150 V =	2 A	1,7 A
	115V	85-132 V ≈	5 A (6 A*)	4,3 A (5,1 A*)

Output is protected against short circuit, open circuit and overload \* short-term (< 1 min), at 45°C or forced cooling even continuous

Derating typ. 3 W/K (at T<sub>amb</sub>=+60°C...+70°C)

Voltage regulation better than 2% V<sub>out</sub> overall

Ripple / Noise < 25 mV<sub>pp</sub>, (20 MHz bandw., 50 Ω measurement.)

Overvolt. protection typ. 33 V

Parallel operation yes; current sharing available on request

Power back immunity 34 V

Front panel indicator Green LED, goes out at V<sub>out</sub><12V

### Construction / Mechanics\*

Housing dimensions and Weight

- W x H x D 64 mm x 124 mm x 102 mm (+ DIN rail)
- Free space for ventilation above/below 25 mm recommended left/right 15 mm recommended
- Weight 620 g

Design advantages:

- All connection blocks are easy to reach as mounted at the front panel.
- Input and output are strictly apart from each other and so cannot be mixed up (Input below, output above).

### Order information

Order number	Description
SL5.102	
SLZ01	Screw mounting set, two needed per unit

### Start / Overload Behaviour

Startup delay	typ. 0.1 s
Rise time	ca. 5-20 ms, depending on load
Overload Behaviour	Special PULS Overload Design (see diagram overleaf), so in case of overload <ul style="list-style-type: none"> <li>no disconnection, no hiccup</li> <li>high overload current (up to <math>1.9 I_{Nom}</math>), <math>V_{out}</math> is gradually reduced with increasing current. Moreover 20% power boost (6A short-term, at 45°C or forced cooling even continuous)</li> </ul>

Advantages:

- High short-circuit current, giving large 'start-up window': unit starts reliably even with awkward loads (DC-DC converters, motors).
- No 'sticking' such as can occur with fold-back characteristics
- Secondary fuses operate reliably

### Further information

For further information, especially about

- EMC
  - Connections
  - Safety, Approvals
  - Mechanics und Mounting,
- see page 2 of the „The SilverLine“ data sheet.

**For detailed dimensions**

see SilverLine mechanics data sheet SL2.5/ SL5/ SL10

### Output Current over Input Voltage

(min., at  $V_{out}=24V$ )

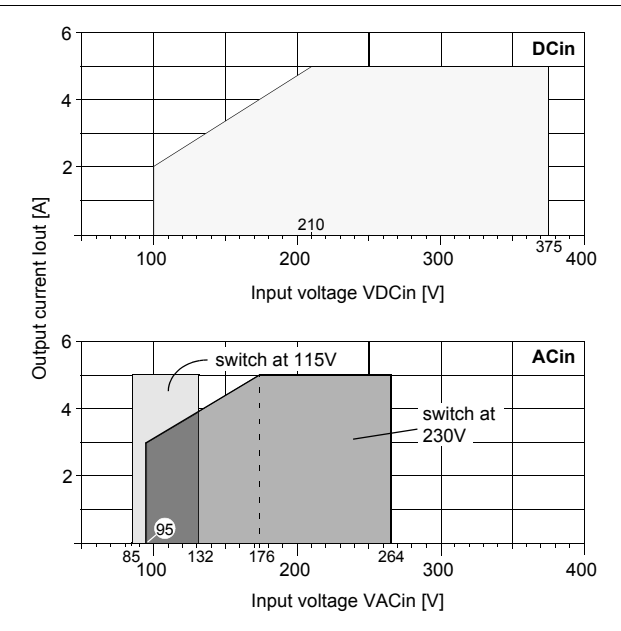

### Output characteristic (min.)

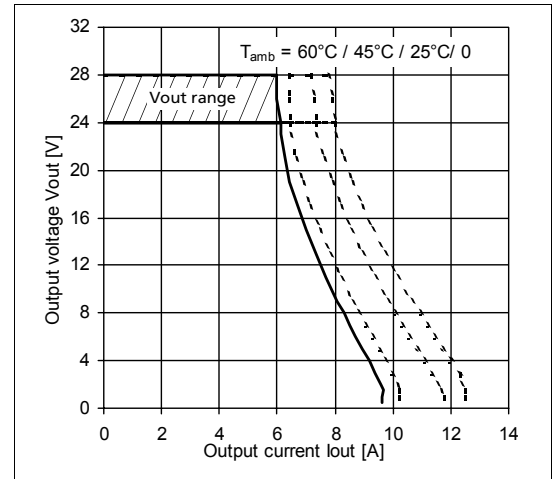

### Hold-up time (min., at $V_{out}=24V$ )

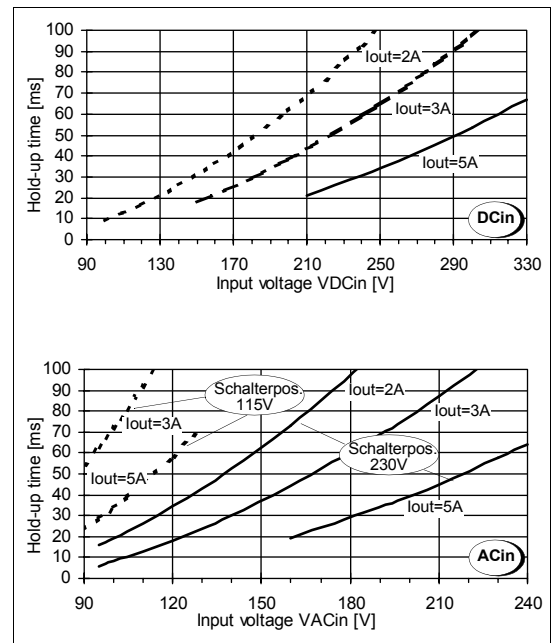

Unless otherwise stated, specifications are valid for AC 230V input voltage, +25°C ambient temperature, and 5 min. run-in time. They are subject to change without prior notice.

### Your partner in power supply:



Bayerns Best 50  
Czech 100 Best  
EuropeOs 500

**PULS GmbH**  
 Arabellastraße 15  
 D-81925 München  
 Tel.: +49 89 9278-0  
 Fax: +49 89 9278-199  
 www.puls-power.com

## SL2.5/ SL5/ SL10

- Innovative DIN-Rail mount, unit holds even at vibration or lateral pressure
- Clearly arranged and user oriented
- Large, robust screw terminals
- Sealed metal housing
- Fine ventilating grid



Data sheet

**Side view SL2.5**

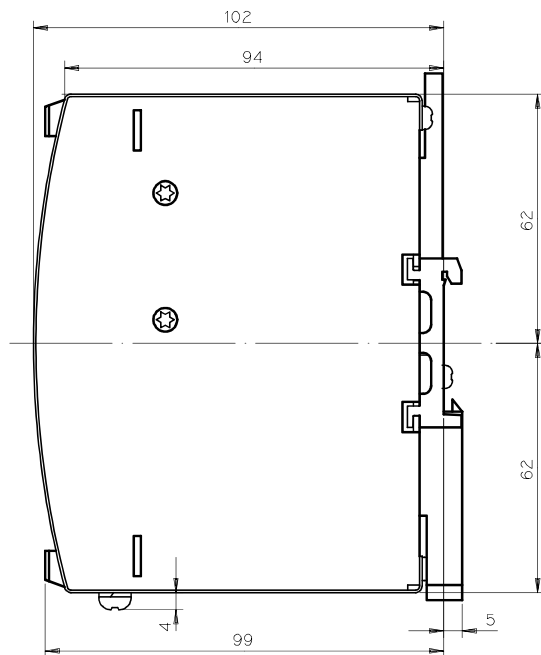

**Front view SL2.5**

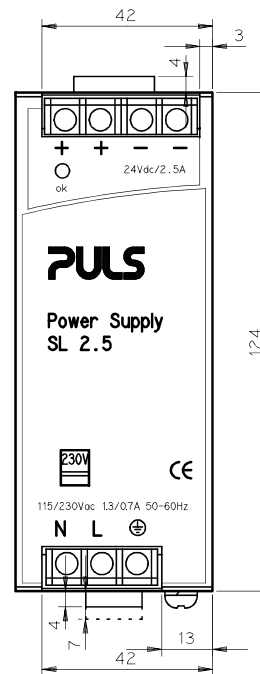

**Bottom view SL2.5**

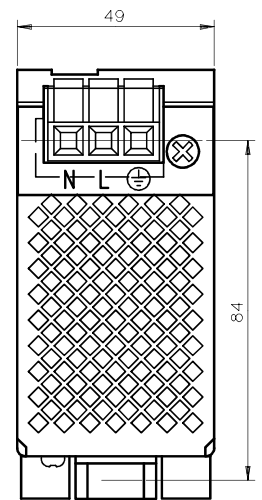

### Construction / Mechanics

Unit	Housing dimensions and Weight		Free space for ventilation		
	W x H x D [mm]	weight	left	above/below	right
• <b>SL2.5</b>	49 x 124 x 102	460 g	0 mm	25 mm each	10 mm
• <b>SL5.10x</b>	64 x 124 x 102	620 g	15 mm	25 mm each	15 mm
• <b>SL5.300</b>	73 x 124 x 117	730 g	15 mm	50 mm each	15 mm
• <b>SL10</b>	120 x 124 x 102	980 g	15 mm	25 mm each	15 mm

Overall depth = depth value as mentioned + DIN rail depth

Robust metal housing with fine ventilat. grid (◇ 3,5 mm, IP20), to keep out small parts (e.g. screws)

Mounting on DIN-Rail (TS35/7.5 or TS35/15, 1...1.5 mm thick), thus

- Simple snap-on system
- Sits safely and firmly on the DIN-Rail
- No tools required to remove

or backplane-mounted (two optional screw mounting sets SLZ01 required)

### Connections

Connections

- Input/Output
- Current handling capacity
- Grid

Screw terminals, connector size range: solid 0.5- 6 mm<sup>2</sup> / flexible 0.5- 4 mm<sup>2</sup>  
30 A per output  
Two connectors per output, 9 mm distance between adjacent connectors

Design advantages:

- All connection blocks are easy to reach as mounted at the the front panel.
- Input and output are strictly apart from each other and so cannot be mixed up

### Order information

Order number	Description
SL2.100	24V/2.5A
SL2.103	12-15V/40W
SL5.100	24V/5A
SL5.102	24-28V/120W
SL5.105	24-28V/120W
SL5.300	24-28V/120W, 3AC400-500V input
SL10.100 and SL10.105	24-28V/240W
SL10.101	48-56V/240W
SLZ01	Screw mounting set, two needed per unit

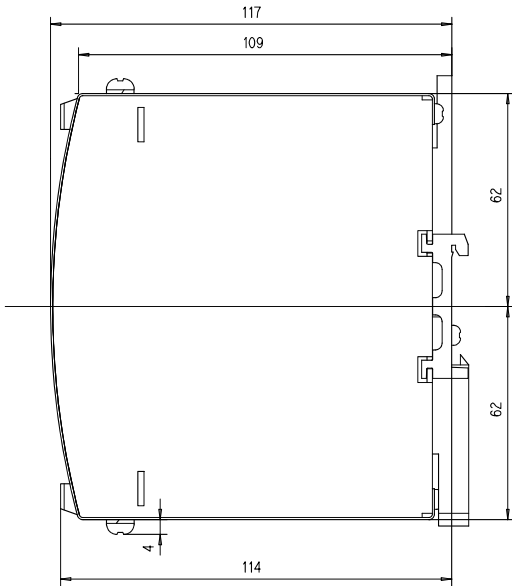

**All views SL5.300**

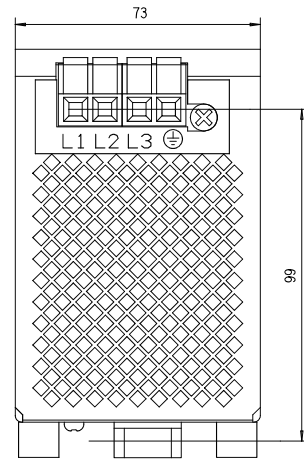
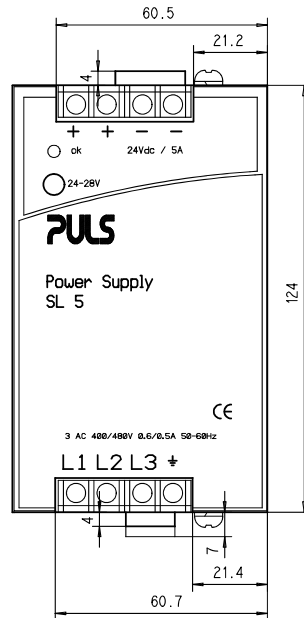

**Bottom view  
SL10 SL5.10x**

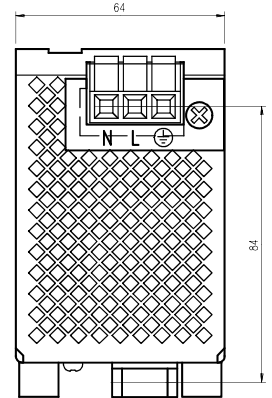
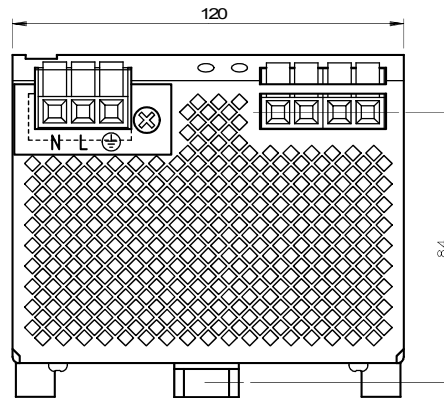

**Side view and front view  
SL10, SL5.10x**

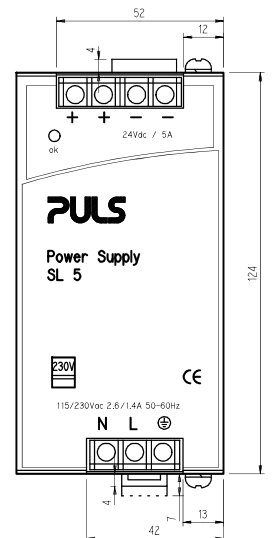
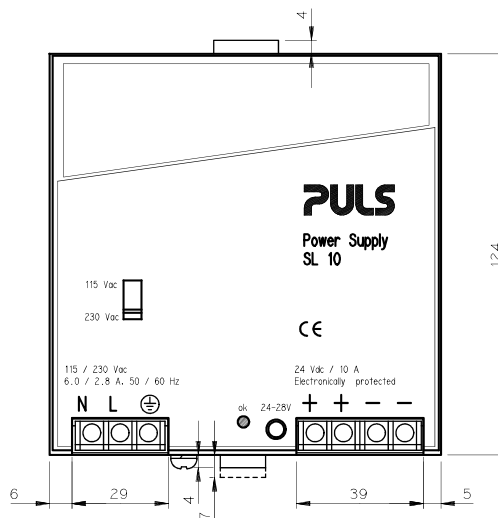
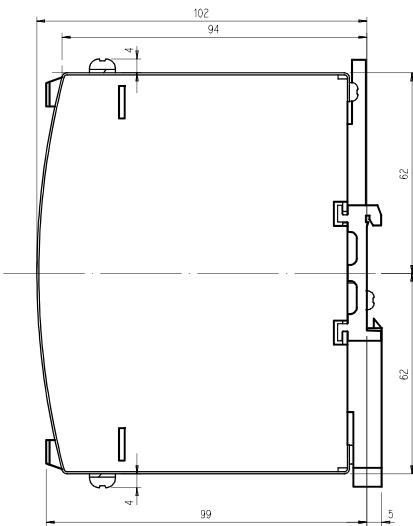

This 'mechanics data sheet' exclusively deals with the mechanical properties of the product. For further information (especially concerning electrical properties), please refer to the generic data sheet of the SL2.5, SL5 and SL10 and to the basic data sheet „The SilverLine“ dealing with common features of all SilverLine units. This data sheet is subject to change without prior notice.

**Your partner in power supply:**



Bayerns Best 50  
Czech 100 Best  
EuropeOs 500

**PULS GmbH**  
Arabellastraße 15  
D-81925 München  
Tel.: +49 89 9278-0  
Fax: +49 89 9278-199  
www.puls-power.com