

©1960 BY AMP INCORPORATED. ALL RIGHTS RESERVED. AMP PRODUCTS COVERED BY PATENTS AND/OR PATENTS PENDING.

NUMBER 42637

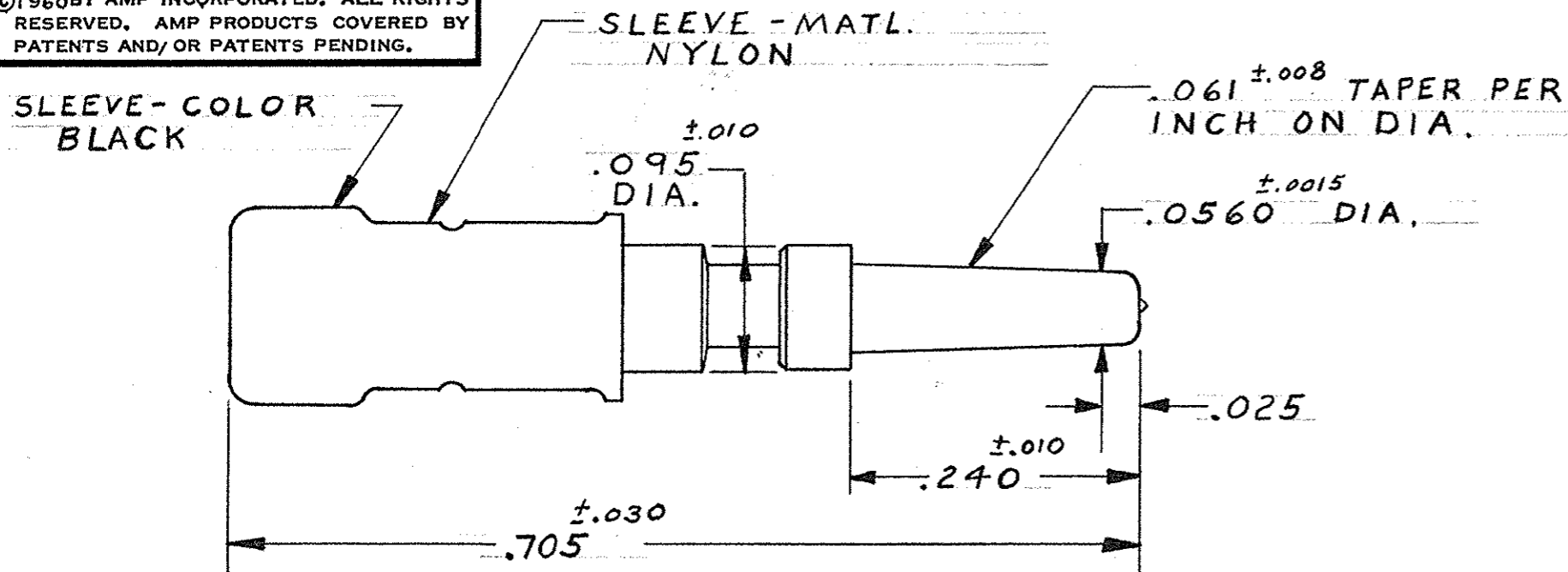

REVISIONS				
ZONE	LTR	DESCRIPTION	DATE	APPROVED
	N-1	REDRAWN AND REVISED	1678 3-26-8	M.S. D.H.
	P	PRINT DIST WAS "39" LOC WAS "AB"	9347 10-72	CO
	R	.705 WAS .715 ECN 7803	7-10-74	MAV
	S	BRIGHT TIN-LEAD WAS TIN	EA 1818 6-18-81	DS
	T	OBS -5, -6 & -8	ECN 53379 11-24-86	R8
	U	REVISED	ECN 53785 3-2-87	R8
	V	REV PER DF-6307	MS 6-11-88	MPO
	W	REV PER ECN DF-0612	MS 8-11-88	MPO
	Y	REV PER OH14-0139-05	1-26-06	PX RG

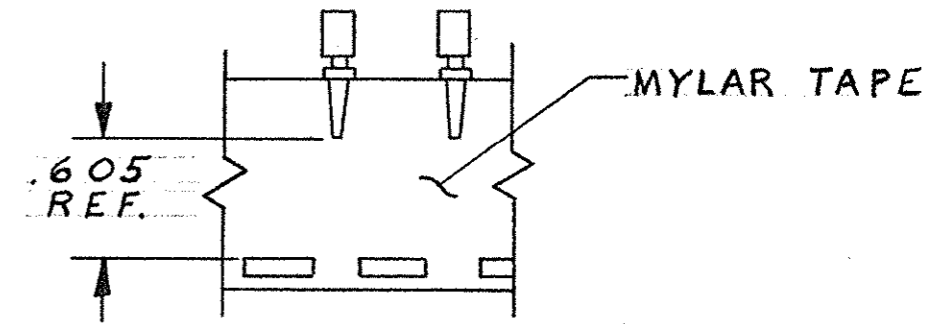

TAPE MOUNTED ASS'Y. NO'S.  
42637-5 THRU 42637-8.

INS. RANGE: .080-.110 DIA  
WIRE RANGE: #16

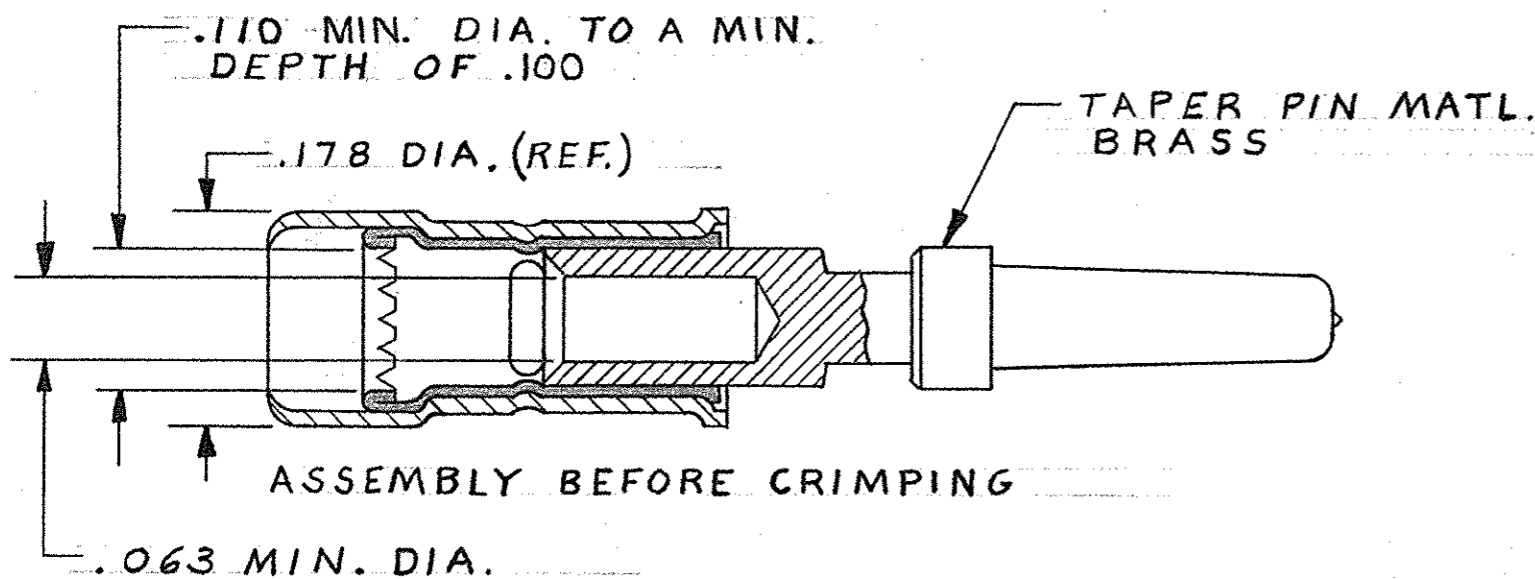

ASSEMBLY BEFORE CRIMPING

	PART NO.	FINISH
	5-42637-1	.0001 MATTE TIN
OBSOLETE	42637-8	.0002 GOLD OVER .000050 NICKEL
	42637-7	.000030 GOLD OVER .000050 NICKEL
OBSOLETE	42637-6	SILVER - .0002 THICK
	42637-5	BRIGHT TIN-LEAD .0002 THICK
	42637-4	.0002 GOLD OVER .000050 NICKEL
	42637-3	.000030 GOLD OVER .000050 NICKEL
OBSOLETE	42637-2	SILVER - .0002 THICK
	42637-1	BRIGHT TIN-LEAD .0002 THICK

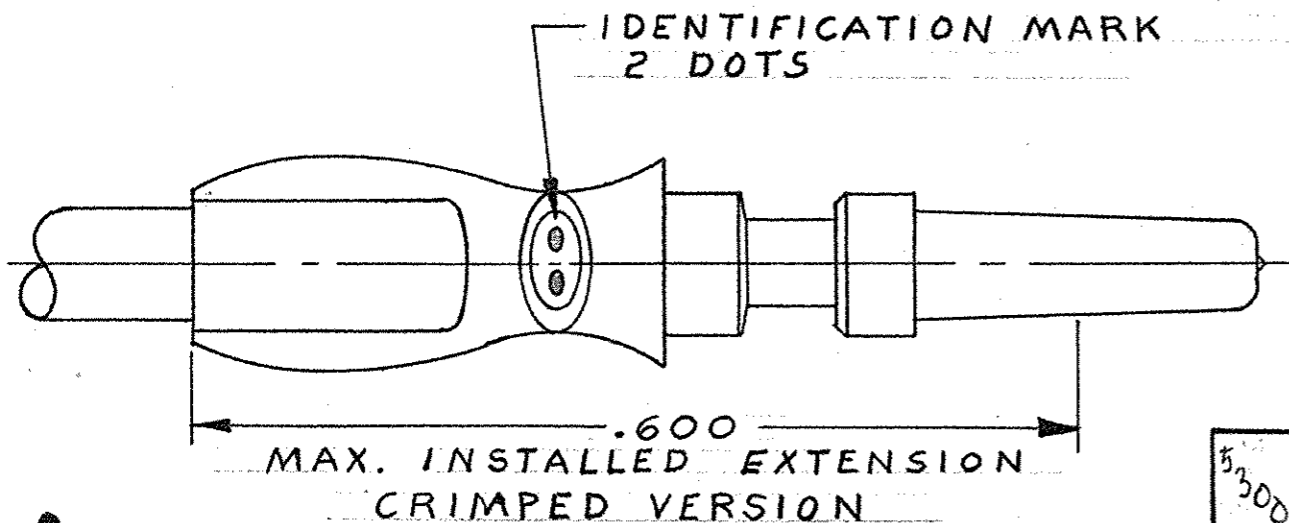

MAX. INSTALLED EXTENSION  
CRIMPED VERSION

UNLESS OTHERWISE SPECIFIED DIM. ARE IN INCHES. TOLERANCES ON: DECIMALS ± .015 ANGLES ±	CONTRACT NO.		<b>AMP</b> AMP INCORPORATED HARRISBURG, PENNSYLVANIA	
	DR	3-25-68		
MATERIAL	CHK	M. Smith	NAME	
	APPD	S. Yeide 5/10/68	PIN, TAPER, "53" SERIES P.I.D.G.	
SEE CALLOUT	DSGN APPD	W. F. Mason 5-15-68	SIZE	CODE IDENT NO.
	HEAT TREAT	#	B	00779
	FINISH	SEE TABLE	NUMBER	42637
AMP INFO	LOC	PRINT DIST	SCALE	WT CALC ACTUAL SHEET
5300	DF		8-1	