

---

**ATAK43001-V1 Development Kit for the  
ATA664251 Atmel IC**

---

**Atmel ATAN0063****Introduction**

---

The development kit for the Atmel® ATA664251 IC consists of the PC interface board (ATAB0004A-V2.0) and the Atmel ATA664251 application board (ATAB664251A-V1.0) attached together as one unit. The kit provides users with a quick start guide for prototyping and testing new LIN designs with the Atmel ATA664251 IC.

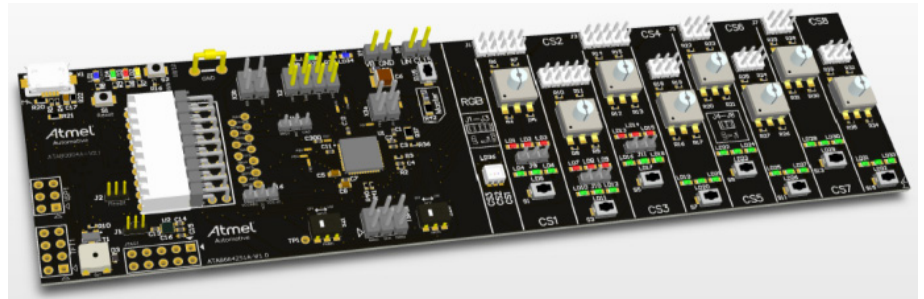
**Figure 1. Atmel ATAK43001-V1 Development Kit**

The Atmel ATA664251 is a system-in-package (SiP) product, which is especially well suited for complete LIN-bus node applications. It is designed specifically for LIN switch applications and includes nearly the complete LIN node. It consists of two ICs in one package supporting highly integrated solutions for in-vehicle LIN networks. The first chip is the ATA664151 LIN system basis chip (SBC), which has an integrated LIN transceiver, a 5V regulator (80mA), a window watchdog, an 8-channel high voltage switch interface with high-voltage current sources and a 16-bit SPI for configuration and diagnosis.

The second chip is an Atmel automotive microcontroller from the AVR 8-bit microcontroller series featuring advanced RISC architecture, the Atmel ATtiny167 with 16 Kbytes of Flash memory.

All the LIN SBC pins as well as all the AVR microcontroller pins are bonded out to provide customers with the same flexibility for their applications they have when using discrete parts.

The Atmel® LIN SBC ATA664251 has the following features:

SBC:

- LIN master and slave operation possible
- Up to 40V supply voltage
- Operating voltage  $V_S = 5V$  to 27V
- 8-channel HV switch interface with HV current sources
- Internal voltage divider for VBattery sensing ( $\pm 2\%$ )
- 16-bit serial interface (daisy-chain-capable) for configuration and diagnosis
- Typically 8 $\mu$ A supply current during sleep mode
- Typically 35 $\mu$ A supply current in active low-power mode
- 5V  $\pm 2\%$  linear low-drop voltage regulator, up to 80mA current capability
- VCC undervoltage detection (5ms reset time) and watchdog reset logical combined at NRES open drain output
- LIN high-speed mode for transmission rates up to 200kBit/s
- Watchdog timer adjustable via external resistor
- Negative trigger input for watchdog
- LIN physical layer complies with LIN 2.1 specification and SAE J2602-2
- Wake-up capability via LIN bus and CL15
- Bus pin is overtemperature and short-circuit protected versus GND and battery
- Advanced EMC and ESD performance
- System-level ESD performance conforming with OEM “Hardware Requirements for LIN in Automotive Applications Rev. 1.2”
- 3x PWM inputs for direct control of the switch interface sources

AVR microcontroller:

- High-performance, low-power AVR® 8-bit microcontroller
- Advanced RISC architecture
  - 123 powerful instructions - in most cases single clock cycle execution
  - 32  $\times$  8 general purpose working registers
  - Fully static operation
- Non-volatile program and data memories
  - 16 Kbytes of in-system programmable (ISP) program memory flash
    - Endurance: 10,000 write/erase cycles
  - 512 bytes in-system programmable EEPROM
    - Endurance: 100,000 write/erase cycles
  - 512 bytes internal SRAM
  - Programming lock for self-programming Flash program and EEPROM data security
- Peripheral features
  - LIN 2.1 and LIN 1.3 controller or 8-bit UART
  - 8-bit asynchronous timer/counter0
    - 10-bit clock prescaler
    - One output compare or 8-bit PWM channel
  - 16-bit synchronous timer/counter1
    - 10-bit clock prescaler
    - External event counter
    - Two output compare units or 16-bit PWM channels each driving up to four output pins

- Master/slave SPI serial interface
- Universal serial interface (USI) with start condition detector (master/slave SPI, TWI, ...)
- 10-bit ADC
  - 11 single-ended channels
  - Eight differential ADC channel pairs with programmable gain (8x or 20x)
- On-chip analog comparator with selectable voltage reference
- 100µA ±10% current source (LIN node identification)
- On-chip temperature sensor
- Programmable watchdog timer with separate on-chip oscillator
- Special microcontroller features
  - Dynamic clock switching (external/internal RC/watchdog clock) for power control, EMC reduction
  - DebugWIRE on-chip debug (OCD) system
  - Hardware in-system programmable (ISP) via SPI port
  - External and internal interrupt sources
  - Interrupt and wake-up on pin change
  - Low-power idle, ADC noise reduction, and power-down modes
  - Enhanced power-on reset circuit
  - Programmable brown-out detection circuit
  - Internal calibrated RC oscillator 8MHz
  - 4MHz to 16MHz and 32kHz crystal/ceramic resonator oscillators
- I/O
  - 16 programmable I/O lines
- Speed grade
  - 0MHz to 16MHz at 4.5V to 5.5V (automotive temperature range: –40°C to +125°C)

This document has been developed to provide users with start-up information about the Atmel ATAK43001-V1 development kit. For more information about the use of the devices themselves, see the appropriate datasheet.

## 1. Development Kit Features

The development kit for the Atmel® ATA664251 IC has the following features, starting with the features of the Atmel ATA664251 (ATAB664251A-V1) board:

- All necessary components to put the Atmel ATA664251 into operation are included to simulate and test the real application
- LEDs connectable to all HV ports
- 1x RGB LED
- 8x push-buttons
- 8x rotary switches
- Easy access to all pins
  - ISP connector for on-chip ISP (in-system programming)
- Easily adaptable watchdog times by replacing a single resistor
- Possibility of selecting between master or slave operation (mounting D2 and R1)
- Push button included for creating a local wake-up after entering sleep mode
- Easily adaptable current level of the current sources by replacing a single resistor
- Ground coulter clip for connecting probes easily when measuring with the oscilloscope

The interface board (Atmel ATAB0004A) has the following features:

- Easy connection to a PC (AT90USB1287 on board)
- USB interface to PC
- SBC functions easily configurable via PC GUI
- ISP connector for in-chip ISP (in-system programming)
- JTAG connector for on-chip debugging
- Buzzer
- On-board RESET button
- On-board boot loader button to force AVR® into DFU mode at reset
- 16MHz crystal for system clock

## 2. Getting Started

The development kit for the Atmel® ATA664251 is shipped with the default jumper settings and all accessories required for immediate use.

Figure 2-1. Atmel ATAK43001-V1 Development Kit with Reference Points

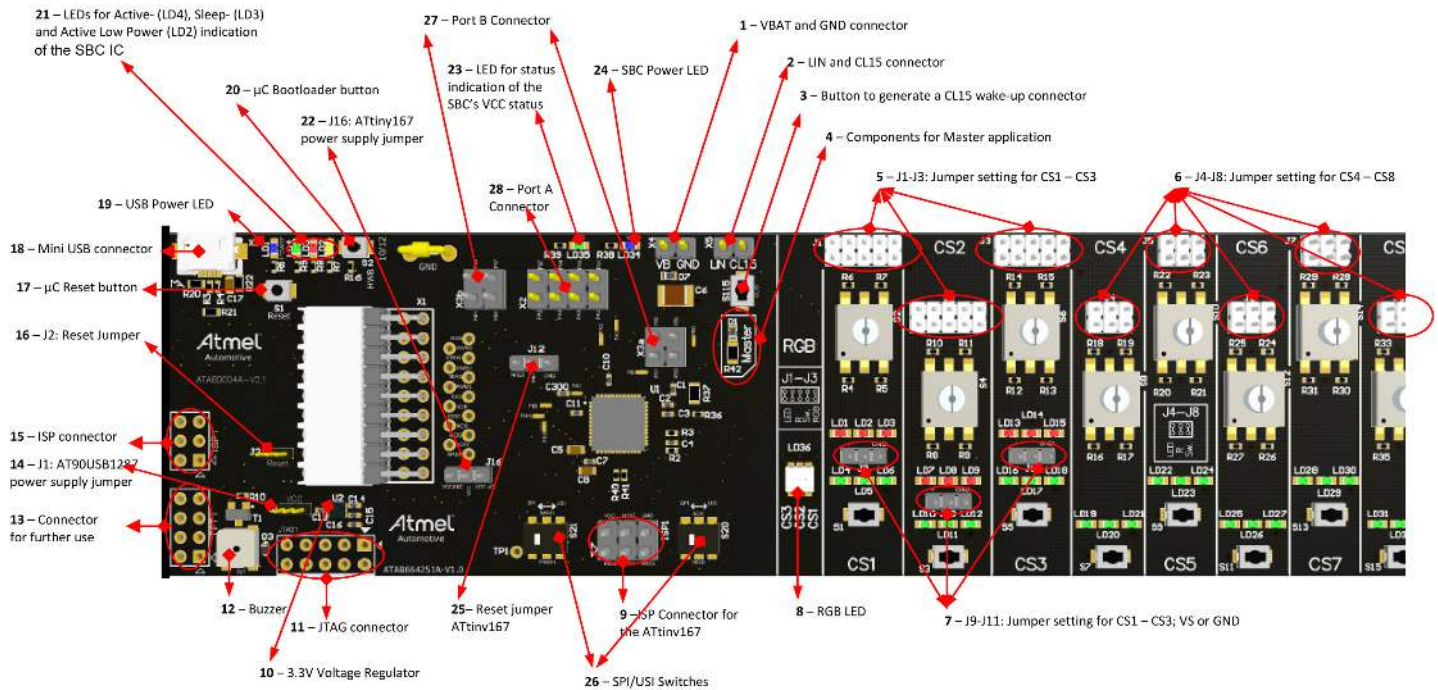

The IC mounted on the PC interface board (AT90USB1287) is preprogrammed with firmware which facilitates testing and gaining familiarity with the basic functions of the kit.

The microcontroller within the Atmel ATA664251 (Atmel ATtiny167) is held in reset via jumper J12 and the SCB is controlled via the PC interface board and the demo GUI.

First of all the USB drivers and the GUI software have to be installed (please see [Section 2.2 “USB Driver Installation” on page 8](#) and [Section 2.1 “GUI Software Installation” on page 7](#) for more information). After correctly connecting an external 12V DC power supply (reference point 1) to the power connector and connecting the PC interface board to the PC via the supplied USB cable, the kit is ready to use.

The Atmel ATA664251 IC starts in active mode, with the VCC voltage regulator, the window watchdog switched on (the latter depends on the VDIV pin, see [Section 5.7 “Watchdog Section” on page 39](#)), the AVR core is in reset (reset pin (pin 2) is connected by default to GND via jumper J12). The status of all pins is shown in [Table 2-1 on page 6](#).

**Table 2-1. Overview of Pin Status at Power-Up of the Development Kit**

Test Point	Expected Behavior	Additional Information
NTRIG	5V	
TXD	5V	
RXD	5V	
NRES	≈ 5ms reset pulse with ≈ 165ms period, because the watchdog is not triggered	
NIRQ	0V	
MISO	0V	
MOSI	0V	
SCK	0V	
NCS	5V	
PWM1	0V	
PWM2	0V	
PWM3	0V	
VDIV	0V	
LIN	≈ 12V	Dependent on the supply voltage (VBAT-0.7V)
CL15	0V	
J16	≈ 5.1V	If jumper J1 (controller board) is set, this jumper should be open.
J2	≈ 5ms reset pulse with ≈ 165ms period, because the watchdog is not triggered	
J1	≈ 5.1V	Default setting, otherwise ≈ 3.3V
Jxx	0V	Default setting: connected to GND
VCC (pin 14)	5V	Voltage regulator is ON
PA0...7	0V	AVR is in reset --> I/Os in tristate
PB0...7	0V	AVR is in reset --> I/Os in tristate
CS1...8	0V	Switch interface is OFF

## 2.1 GUI Software Installation

To install the GUI, execute the setup.exe file and follow the instructions to complete the installation. Select the directory where you want to install the demo and click “Next.”

Figure 2-2. Selecting the Directory

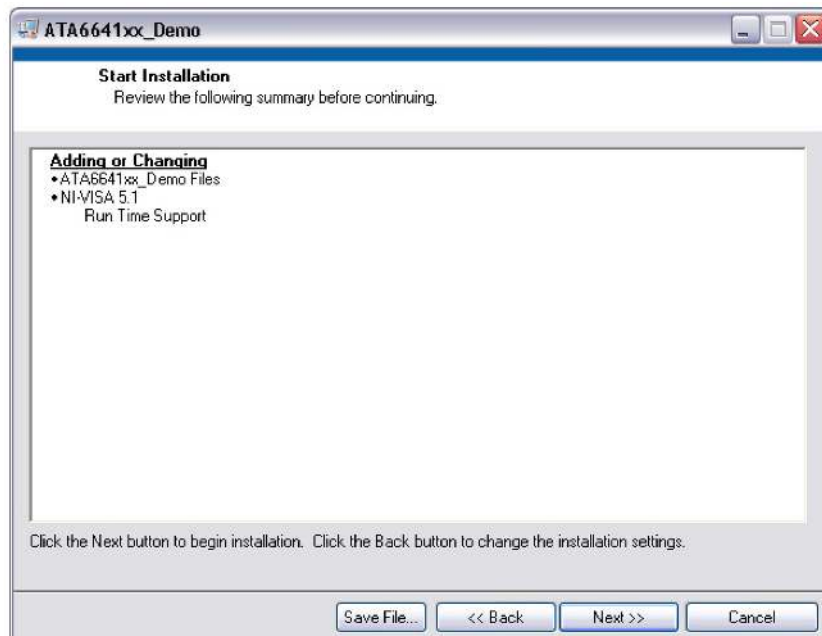
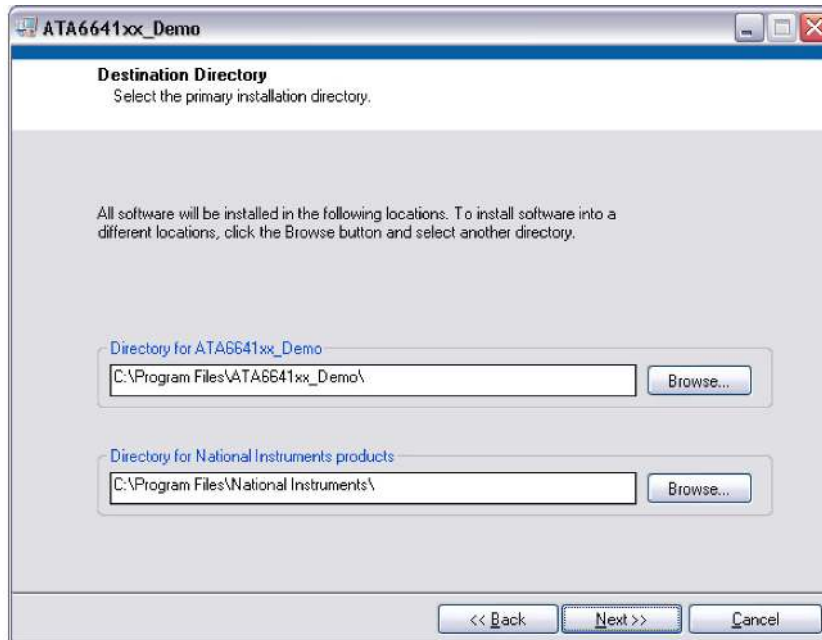

After the installation is done, press “Finish.”

**Figure 2-3. Completing the Installation**

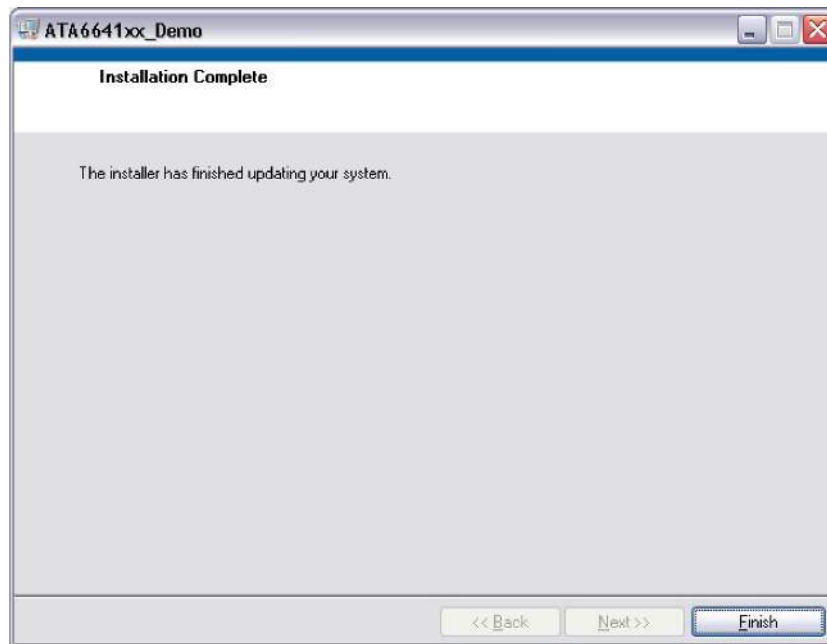

## 2.2 USB Driver Installation

After connecting the PC interface board to a PC the first time, the required USB drivers must be installed before the kit can be used.

Be sure to install the GUI first before installing the USB driver (see [Section 2.1 “GUI Software Installation” on page 7](#)).

As soon as the PC has detected a new hardware device, the “Hardware Wizard” appears. Select “No, not this time” and then click “Next.”

**Figure 2-4. Selecting “No, not this time”**





Select “Install from a list or specific location” and then click “Next.”

**Figure 2-5. Selecting “Install from a list or specific location (advanced)”**



Select “Don’t search. I will choose the driver to install.” and then click “Next.”

**Figure 2-6. Selecting “Don’t search. I will choose the driver to install.”**



If more than one driver is found, be sure to select the “Destiny National Instruments” driver and then click “Next.”

**Figure 2-7. Selecting the “Destiny National Instruments” Driver**



**Figure 2-8. Installing the Driver**

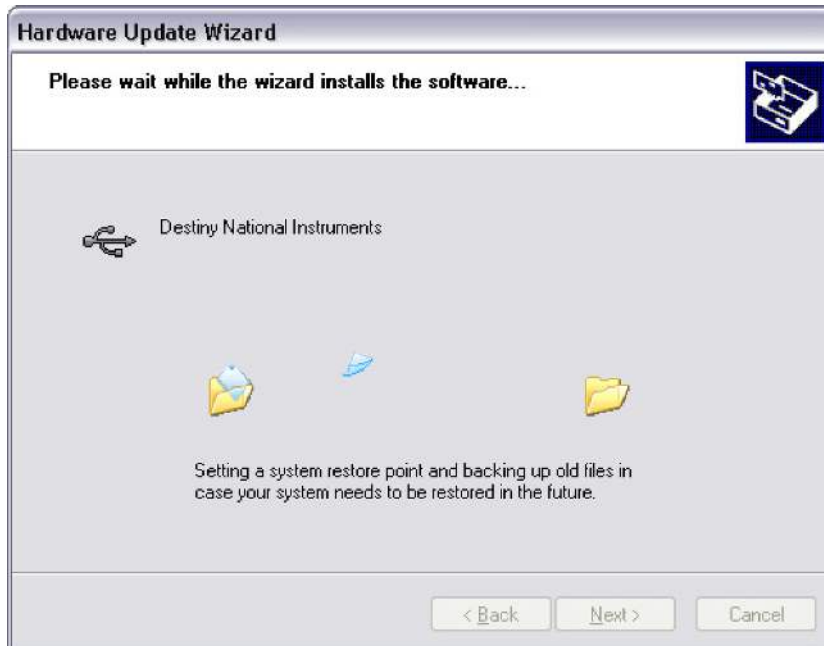

After successfully installing the driver, press the “Finish” button.

**Figure 2-9. Selecting “Finish”**



## 2.3 Quick Start User Guide

1. To start working with the kit, execute the Atmel® ATA6641\_Demo.exe. This can be done either from the “Start” menu or from the folder containing the kit files (see [Section 2.1 “GUI Software Installation” on page 7](#)). Before starting the GUI, make sure the correct USB driver (see [Section 2.2 “USB Driver Installation” on page 8](#) for more information) and GUI software are installed and that the power supply and USB are properly connected. The following window is opened so that the user can set up and test all the features of the SBC.

Figure 2-10. Atmel ATA664251 Demo GUI at Start-up



After starting up the GUI, as standard the SBC is set to low-power mode. This is indicated in [Section 5.1 “SBC Section” on page 34](#) (yellow LED - ActiveLP is ON) in the GUI and on the PC interface board (LED - LD2 is ON (reference point 21)) as well (see [Figure 2-12](#)).

2. A quick check to determine everything is working properly can be done by clicking the “Active Mode” button in the SBC section where all “Bit Buttons” in [Section 5.5 “I/O Ports Section” on page 36](#) are checked (please see [Figure 2-11](#)) and the following LEDs on the ATAB664251A board (please see [Figure 2-12](#)) are turned on:
  - LD1-3 (indicate that CS1 is set to low-side ON)
  - LD7-9 (indicate that CS4 is set to low-side ON)
  - LD13-15 (indicate that CS3 is set to low-side ON)
  - LD19-33 (indicate that CS4-8 are ON)

Figure 2-11. Atmel ATA664251 Demo GUI after “Active Mode” Button Is Pressed

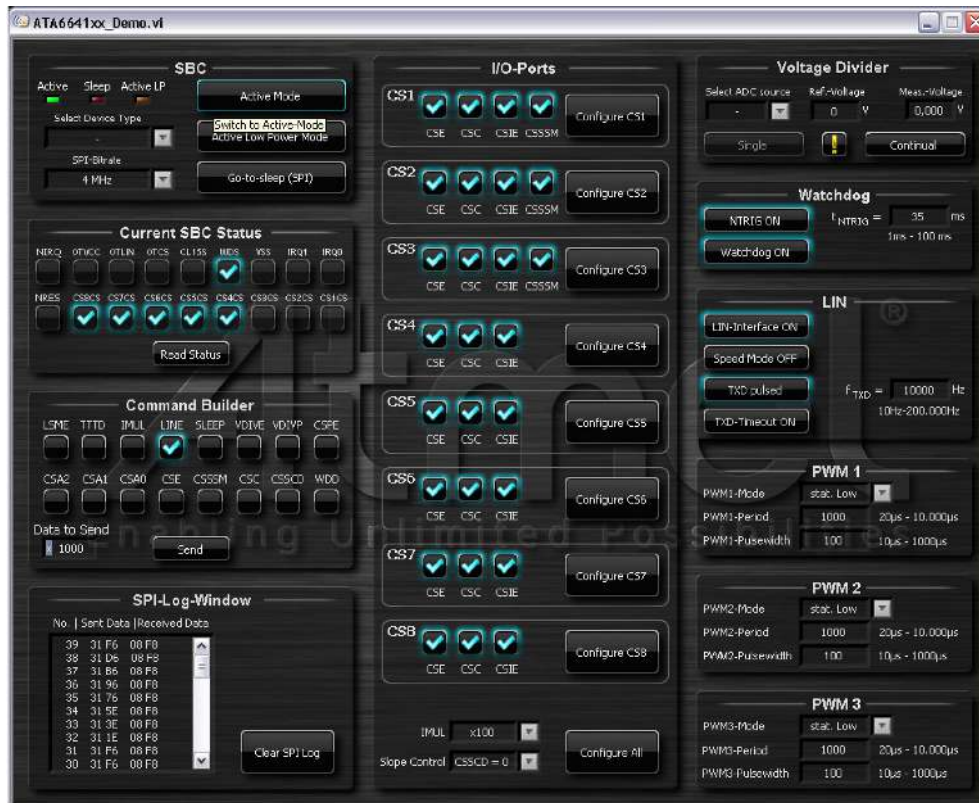
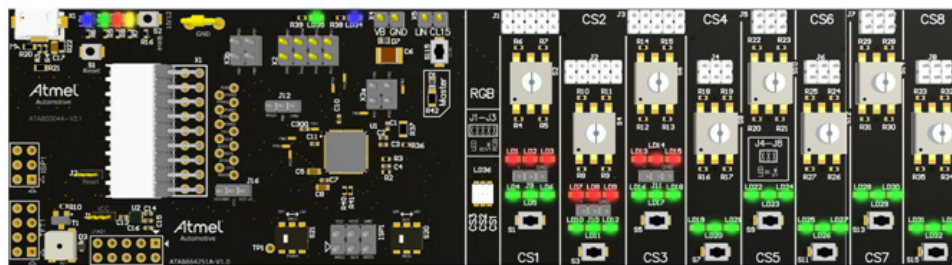

Figure 2-12. Atmel ATAK43001-V1 Kit LEDs in Active Mode



In active mode, the watchdog and a valid trigger signal (35ms) are activated. In addition, the LIN interface is enabled and a default frequency of 10kHz (20kBit/s) is generated on the TXD pin.

In order to have a LIN signal approximating a real LIN network, a master pull-up and a master diode (reference point 4) are populated on the board (see [Section 3.6.3 “Configuring the Atmel ATAK43001-V1 Kit as a Master or a Slave Node” on page 30](#)).

- It is relatively easy to change the mode of the SBC. Click one of the three mode buttons in [Section 5.1 “SBC Section” on page 34](#). The current mode is indicated in the GUI (3x LEDs in [Section 5.1 “SBC Section” on page 34](#)) and on the PC interface board (reference point 21; LEDs - LD2, LD4, LD4) as well. For more information about the different modes, see [Section 5.1 “SBC Section” on page 34](#) or the ATA664251 datasheet.

Figure 2-13. Mode Change



4. To better understand the features of the high-voltage I/O ports, try changing various settings for the I/O ports by:
  - Enabling/disabling a specific CSx port (select/deselect the CSE bit and click the appropriate “Configure CSx” button)
  - Configure CS1...3 as low-side or high-side by selecting/deselecting the CSSSM bit and click the appropriate “Configure CS1...3” button
  - Configure one of the CS1...8 ports to be controlled either by PWM signal or not: Select/deselect the CSC bit and click the appropriate “Configure CS1...8” button. Make sure the dedicated PWM1...3 signals in the corresponding section of the GUI have been enabled (for more information, see [Section 5. “Atmel ATA664251 Demo GUI Description” on page 33](#)).
  - Double/halve the current of the CS1...8 ports by selecting either “x100” or “x50” for the IMUL bit.

Figure 2-14. CSx Port Setting



- The VBattery voltage or the voltage on the I/O ports can be easily measured (one at a time) at the VDIV pin. To do so, select the desired source in the “Voltage Divider” section (at the upper right side of the GUI) that has to be measured and press the “Continual” button for continuous measurement of the selected source.

**Figure 2-15. Selecting the Voltage Measurement Source**



- For testing purposes and to become familiar with the system, it may be helpful to see the behavior when the watchdog is not triggered correctly. This can be done in two different ways without changing the firmware of the IC:
  - Disable NTRIG frequency (click on the “NTRIG ON/OFF” button)  
No trigger signal reaches the watchdog and the watchdog generates a reset directly after the lead time  $t_d$  ( $51k\Omega$ ) = 155ms has expired.
  - Re-program the fuse bit  
Changing the CKDIV8 fuse bit to be programmed changes the microcontroller’s internal clock from 16MHz to 2MHz. Because of this the trigger signal generated from the microcontroller does not meet the open window from the window watchdog and a reset is generated.

In this case the watchdog generates resets ( $\approx 5ms$  reset pulse with  $\approx 165ms$  period) on the NRES pin (displayed also in the GUI in the “Current SBC Status” section).

## 3. Hardware Description

### 3.1 Pin Description - ATAB664251A Board

In the following sections, the external elements required for some of the pins are shown and described. See the relevant datasheet for more information about this topic.

Note: The Atmel® ATA664251's AVR® is held in reset (J12 connected to GND) and it is not supplied (J16 is open).

#### 3.1.1 Power Supply

In order to get the Atmel ATAB664251A development board running, an external 5V to 27V DC power supply has to be connected to the power connector. The input circuit is protected against inverse polarity with the protection diode D7, resulting in a difference of approximately 0.7V between the VBAT supply voltage and the voltage at the VS pin.

In order to avoid false bus messages, undervoltage detection is implemented to disable data transmission via the LIN bus and the switch interface if  $V_{VS}$  falls below  $V_{VStH}$ . After switching on VS, the IC starts in active mode (for more information, please see also Section 4.1 "Active Mode" in the Atmel ATA664251 datasheet) with the VCC voltage regulator and the window watchdog switched on.

#### 3.1.2 Voltage Regulator (VCC)

The internal 5V voltage regulator is capable of driving loads up to 80mA for supplying the microcontroller and other loads. It is protected against overloads by means of current limitation and overtemperature shutdown. In addition, the output voltage is monitored and causes a reset signal at the NRES output pin if it drops below a defined threshold  $V_{VCCthun}$ .

A safe operating area (SOA) is defined for the voltage regulator because the power dissipation caused by this block might exceed the system's thermal budget (please see the Atmel ATA664251 datasheet for more detailed information).

#### 3.1.3 The Window Watchdog (NTRIG, WD\_OSC, and NRES)

The watchdog anticipates a trigger signal from the microcontroller at the NTRIG input (negative edge) within a defined time window. If no correct trigger signal is received during the open window, a reset signal (active low) is generated at the NRES output. During silent mode or sleep mode the watchdog is switched off to reduce current consumption.

The timing basis of the watchdog is provided by the internal oscillator, whose time period  $t_{OSC}$  can be adjusted via the external resistor R2 at the WD\_OSC pin. All watchdog-specific timings ( $t_1$ ,  $t_2$ ,  $t_d$ , ...) are based on the value of this resistor. There is a resistor with a value of 51k $\Omega$  mounted on the development board by default, resulting in the timing sequence for the integrated watchdog in [Figure 3-1](#).

Figure 3-1. Watchdog Timing Sequence with R2 = 51k $\Omega$

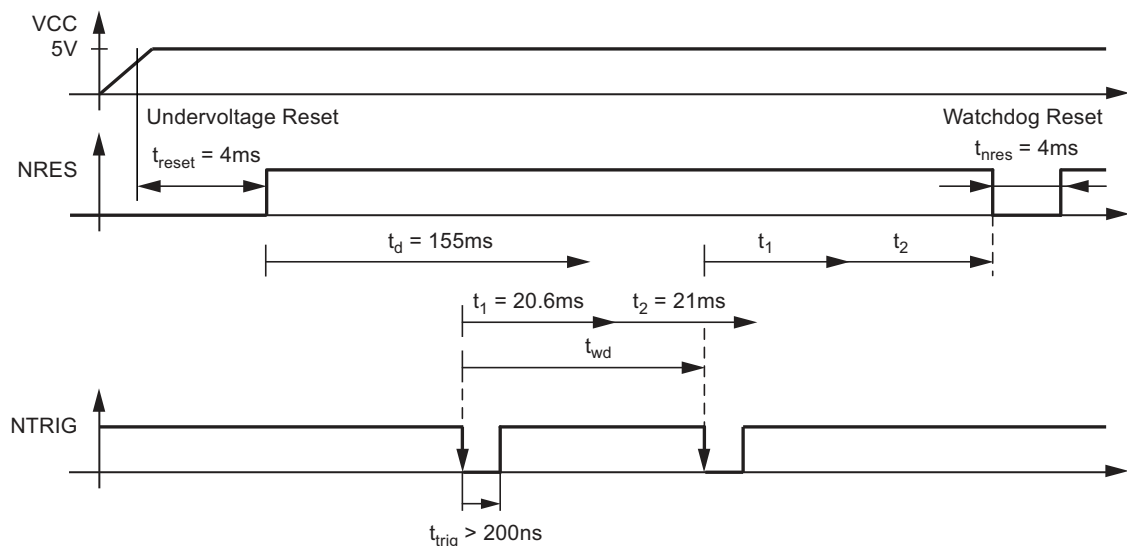



Replacing the resistor R2 results in a frequency change of the internal oscillator. This in turn results in different watchdog timing. The following formula demonstrates how the frequency of the internal oscillator depends on the value of the resistor R2. For more information, see the Atmel ATA664251 datasheet. The resistor  $R_{wd\_osc}$  in the datasheet corresponds to resistor R2 on the board:

$$t_{OSC} [R_{WD\_OSC}] = 0.405 \times R_{WD\_OSC} - 0.0004 \times (R_{WD\_OSC})^2$$

$t_{OSC}$  in  $\mu s$

$R_{WD\_OSC}$  in  $k\Omega$

With the values given in the datasheet, all relevant watchdog times (such as the open window and closed window) can be calculated using  $t_{OSC}$ .

In general, the AT90USB1287 is shipped with an oscillator start-up time of 65ms. Due to the extra-long lead time of 155ms it should be possible in almost all cases to meet the first open window of the watchdog. If more time is needed, the 65ms default start-up time of the microcontroller can be reduced via the fuse bits to 4.1ms or even 0ms. The IC mounted on the board is shipped preset to a start-up time of 65ms.

### 3.1.4 The LIN Interface (LIN, TXD, and RXD)

A low-side driver with internal current limitation and thermal shutdown, and an internal pull-up resistor in compliance with the LIN 2.1 specification are implemented. The allowed voltage range is from  $-30V$  to  $+40V$ . Reverse currents from the LIN bus to VS are suppressed, even in the event of GND shifts or battery disconnection. The LIN receiver thresholds are compatible with the LIN protocol specification. The fall time from recessive to dominant bus state and the rise time from dominant to recessive bus state are slope-controlled.

For higher bit rates the slope control can be switched off by setting the SPI-bit LSME. Then the slope time of the LIN falling edge is  $< 2\mu s$ . The slope time of the rising edge is highly dependent on the capacitive load and the pull-up resistance at the LIN line. To achieve a high bit rate Atmel recommends using a small external pull-up resistor ( $500\Omega$ ) and a small capacitor. This allows very fast data transmission of up to 200kBit/s, e.g., for electronic control tests of the ECU, microcontroller programming, or data download. In this high-speed mode superior EMC performance is not guaranteed.

Note: The internal pull-up resistor is only switched on in active mode and when the LIN transceiver is activated by the LINE bit (active mode with LIN bus transceiver).

Because the two TXD and RXD pins on the LIN SBC are controlled by the microcontroller's LIN/UART, they are connected to the corresponding TXD and RXD pins on the microcontroller and can be monitored at these pins. Test points have been provided on the development board.

#### 3.1.4.1 TXD Input Pin (LIN SBC)

The TXD pin is the microcontroller interface for controlling the state of the LIN output. TXD must be pulled to ground in order to keep the LIN bus in the dominant state. If TXD is high or not connected (internal pull-up resistor), the LIN output transistor is turned off and the bus is in recessive state.

If configured, an internal timer prevents the bus line from being constantly driven in the dominant state. If TXD is forced to low for longer than  $t_{DOM}$ , the LIN bus driver is switched back to recessive state. TXD has to be switched to high for at least  $t_{TOrel}$  to reactivate the LIN bus driver (by resetting the time-out timer).

As mentioned above, this time-out function can be disabled via the SPI configuration register in order to achieve any long dominant state on the connected line (such as PWM transmission or low bit rates).

### 3.1.4.2 RXD Output Pin (LIN SBC)

This output pin reports the state of the LIN bus to the microcontroller. SLIN high (recessive state) is reported by a high level, LIN low (dominant state) is reported by a low level at RXD. The output has push-pull characteristics, meaning no external time-defining measures are required. The RXD pin is at high level during disabled LIN-PHY states (configuration bit “LINE” = 0). Please note that the signal on the RXD pin is not valid for a certain period of time upon activation of the LIN transceiver ( $t_{RXDInvalid}$ ).

**Figure 3-2. RXD Timing upon Transceiver Enable**

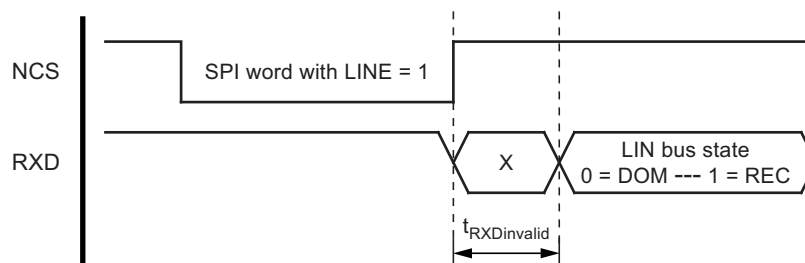

RXD is switched off in sleep and unpowered mode.

### 3.1.5 Interrupt Request Output Pin (NIRQ)

The interrupt request output pin is an open drain output and switches to low whenever a chip-internal event occurs that is set up to trigger an interrupt. A power-up, a wake-up over LIN bus, a change in a switch state, or an overtemperature condition are examples of such events. The pin remains at ground until the end of the next SPI command, at which point the interrupt source is passed to the SPI master.

### 3.1.6 CL\_15 (LIN SBC)

This CL15 pin is a high-voltage input that can be used to wake up the device from sleep mode. It is an edge-sensitive pin (low-to-high transition). Thus, even if CL15 pin is at high voltage ( $V_{CL15} > V_{CL15th}$ ), it is possible to switch to sleep mode. The CL 15 pin is usually connected to the ignition for generating a local wake-up in the application if the ignition is switched on. If not needed, the CL15 pin should be tied directly to ground. A debounce timer with a value  $t_{debCL15}$  of typically 160 $\mu$ s is implemented. The pin state (CL15 ON or OFF) can be read out through the SPI interface.

### 3.1.7 VBATT Pin

The VBATT is a high-voltage input pin for performing measurements using a voltage divider. The latter provides a low-voltage signal at the VDIV pin that is linearly dependent on the input voltage. In an application with battery voltage monitoring, this pin is connected in series to VBattery via a 51 $\Omega$  resistor and a 10nF capacitor to GND. The divider ratio is 1:4. This ratio results in maximum output voltages on the VDIV pin when 20V is reached at the input.

### 3.1.8 NRES Output Pin (LIN SBC) and PB6/Reset Input Pin (Microcontroller at the PC Interface Board)

The NRES reset output pin is an open-drain output and switches to low during a VCC undervoltage event or a watchdog timing window failure. Please note the reset hold time of typically 4ms has disappeared after the undervoltage condition. The PB6/reset input pin already has a pull-up resistor included with resistance between 30k $\Omega$  and 60k $\Omega$ . The NRES output pin of the LIN SBC is connected by default to the PB6 input pin of the microcontroller at the PC Interface board. The NRES pin can be connected to the reset pin of the microcontroller via the JP2 jumper (PC interface board). An additional 10k $\Omega$  pull-up resistor is included on the development board to have a defined value of the NRES output in case the PJ2 is left open.

Because the NRES output is an open-drain output, it is not necessary to remove the J2 jumper (only if placed on position 1 and 2) during programming or debugging of the microcontroller.

### 3.1.9 VDIV Input/Output Pin

This pin handles two different functions. During the VCC start-up and watchdog reset phase (pin NRES driven to LOW), the pin acts as the input and determines the setting of the WDD bit within the SPI configuration register (see [Figure 3-3](#)). In other words, if the window watchdog operation were disabled directly after power-up (e.g., for microcontroller programming or debugging purposes), the VDIV pin would have to be tied to the HIGH level until the reset phase ends (pin NRES has a positive slope from LOW to HIGH). In other cases, such as when the VDIV pin is not driven actively by the application, the signal is assessed as LOW and the WDD bit (watchdog disable) is thus also low and the window watchdog is operational (see [Figure 3-3](#)).

**Figure 3-3. WDD Configuration Bit Setup During VCC Start-up**

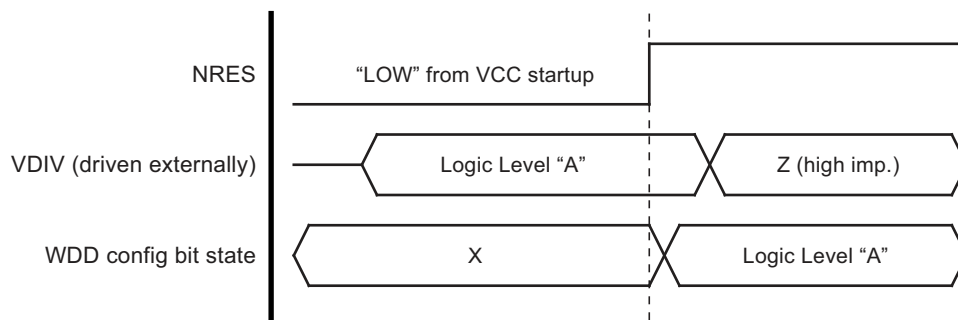

During normal operation, this pin provides a low-voltage signal for the ADC such as for a microcontroller. It is sourced either by the VBATT pin or one of the switch input pins CS1 to CS8. An external ceramic capacitor is recommended for low-pass filtering of this signal (10nF mounted on the board by default; depending on the timings in the current application, this value should be adjusted). If selected in the configuration register of the SPI, this pin guarantees a voltage- and temperature-stable output ratio of the selected test input and is available in all modes except sleep mode. Please note that the current consumption values in the active low-power mode of the Atmel ATA664251 indicated in the electrical characteristics lose their validity if the VDIV output pin is being used in this low-power mode. The voltage on this pin is actively clamped to VCC if the input value would lead to higher values.

### 3.1.10 IREF Output Pin

This pin is the connection for an external resistor toward ground. It provides regulated voltage which causes a resistor-dependent current to be used as reference for the current sources in the switch interface I/O ports. Fail-safe circuitry detects if the resistor is missing or if there is a short circuit toward ground or VCC on this pin. An internal fail-safe current is generated in this event.

### 3.1.11 CS1 to CS8 High-Voltage Input/Output Pins

These pins are intended for contact monitoring and/or constant current sourcing. A total of eight I/Os (pins CS1 through CS8) are available, of which three (CS1, CS2, and CS3) can be configured either as current sources (such as for switches toward ground) or as current sinks (such as for switches toward battery). The other five pins (CS4 to CS8) have current sourcing capability. Apart from a high-voltage (HV) comparator for simple switches, the I/Os are also equipped with a voltage divider to enable analog voltage measurements on HV pins by using the ADC of the application's microcontroller. Also, each input can trigger an interrupt upon state change even while low-power mode is active.

### 3.1.12 PWM1...3 Input Pins

These pins can be used to control the switch interface current sources directly, such as for pulse width-modulated load control or for pulsed switch scanning. For example, they accept logic level signals from the microcontroller and are equipped with pull-down structures so that the input is well defined in case of an open connection. For more information, see the “Switch Interface Unit” section in the Atmel ATA664251 datasheet.

The assignment of the current sources to the three PWM input pins is shown in [Table 3-1](#).

**Table 3-1. CSx Port Configuration Table**

PWM Port	CS1	CS2	CS3	CS4	CS5	CS6	CS7	CS8
PWM1	x	-	-	-	-	-	x	X
PWM2	-	x	-	-	x	x	-	-
PWM3	-	-	x	x	-	-	-	-

### 3.1.13 PA0...7 Input/Output Pins

All I/O pins are easily accessible – PA0...7 on Header X2. Most of the I/O ports are hardwired to the corresponding pins of the SBC. [Table 3-4 on page 29](#) shows the connection between the Atmel ATtiny167 and the SBC. Cut-straps are available to remove the connection between the AVR and the SBC. For more information about the function of the I/O pins, please see the datasheet of the Atmel ATA664251.

### 3.1.14 PB0...7 Input/Output Pins

All I/O pins are easily accessible – PB0...7 on header X3a and X3b. Most of the I/O ports are hardwired to the corresponding pins of the SBC. [Table 3-2](#) shows the connection between the Atmel ATtiny167 and the SBC. A cut-straps are available to remove the connection between the AVR and the SBC. For more information about the function of the I/O pins, please see the Atmel ATA664251 datasheet.

**Table 3-2. Hardwire Connections between the Atmel ATtiny167 and the SBC Table**

ATtiny167	SBC
PA0	RXD
PA1	TXD
PA2	To switch S21
PA3	VDIV
PA4	To switch S20
PA5	To switch S20
PA6	NCS
PA7	Over C300 (100nF) to GND
PB0	To switch S21
PB1	To switch S20
PB2	To switch S20
PB3	NTRIG
PB4	PWM3
PB5	PWM2
PB6	NIRQ
PB7	To jumper J12

## 3.2 Pin Description - Atmel ATAB0004A Board (PC Interface Board)

### 3.2.1 PD4 to PD6 and PC5

Three LEDs are connected to PD4 - PD6 and are used for indicating the status of the SBC:

- Green LED connected to PD4, ON when the SBC is in active mode
- Yellow LED connected to PD5, ON when the SBC is in low active mode
- Red LED connected to PD6, ON when the SBC is in sleep mode

A buzzer is connected to PC5. Currently not used, but if needed can easily be activated via software for any sound indication.

### 3.2.2 JTAG Header

The JTAG header allows users to upload and debug their application with the JTAG programmer.

Figure 3-4. The JTAG Header

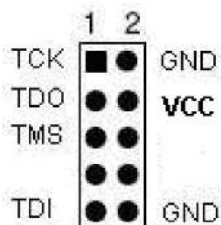

### 3.2.3 ISP Header

The ISP header can be used to program the Atmel® AT90USB1287 through in-system programming.

Figure 3-5. 6-Pin ISP Connector Pinout

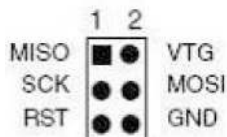

### 3.2.4 Reset Button

The “RESET” push button resets the target AVR® device when pushed.

**Figure 3-6. Reset Button**

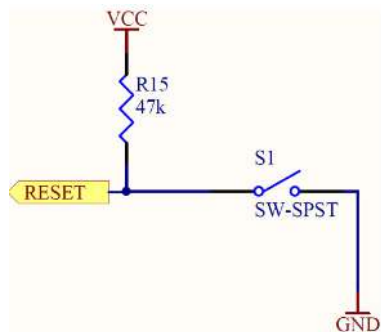

### 3.2.5 Boot Loader Button

The “HWB” push button is used to switch the AVR to DFU mode (boot loader).

The HWB mode of this pin is active only when the HWBE fuse is enabled.

The following steps enable DFU mode:

1. Press and hold the “HWB” push button.
2. Press the “RESET” push button.
3. Release the “RESET” push button.
4. Release the “HWB” push button.

**Figure 3-7. Boot Loader Button**

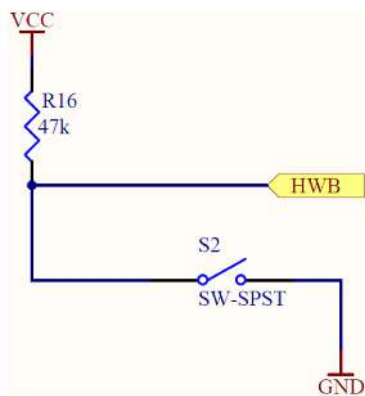

### 3.2.6 Other Pins

All remaining pins not described in this section do not have any special external circuitry and/or are used as described in detail in the next section.

### 3.3 Summary of the Pin Connection

As already described in detail in the previous sections, there are some pins tied together on the development board. The pin connection of the Atmel ATAB664251A board and ATAB0004A board is summarized in [Table 3-3](#).

**Table 3-3. Summary of the Hardwired Pins on the Atmel ATA664251 Kit**

Connector Pin No. (PC Interface Board)	Microcontroller Pin (AT90USB1287)	Connected to Atmel ATA664251	Connector Pin No. (PC Interface Board)
1	PC1	NIRQx	1
2	PC6	NCSx	18
3	PC4	PWM2	2
4	PD2	RXD	17
5	PB5	PWM1	3
6	PE5	NTRIG	16
7	PD0	PWM3	4
8	PE4	NIRQ	15
9	PB1	SCK	5
10	PD3	TXD	14
11	PB0	NCS	6
12	PB3	MISO	13
13	PF0	VDIV	7
14	PB2	MOSI	12
15	GND	GND	8
16	PB6/Reset	NRES	11
17	PF1	VDIVx	9
18	VCC_AVR	VCC_SBC	10

The three connections marked in bold are made via jumpers and the other connections are hardwired with a test point for easy access.

## 3.4 Jumper Description

In order to be more flexible and to meet as many requirements as possible, some jumpers are provided on the development board. With the help of these jumpers, users have the opportunity to work with the system itself in order to test some features and/or to modify the system to meet their requirements. In the following sections all jumpers on the development board are briefly described.

Figure 3-8. Jumpers on the Atmel ATAK43001-V1 Kit

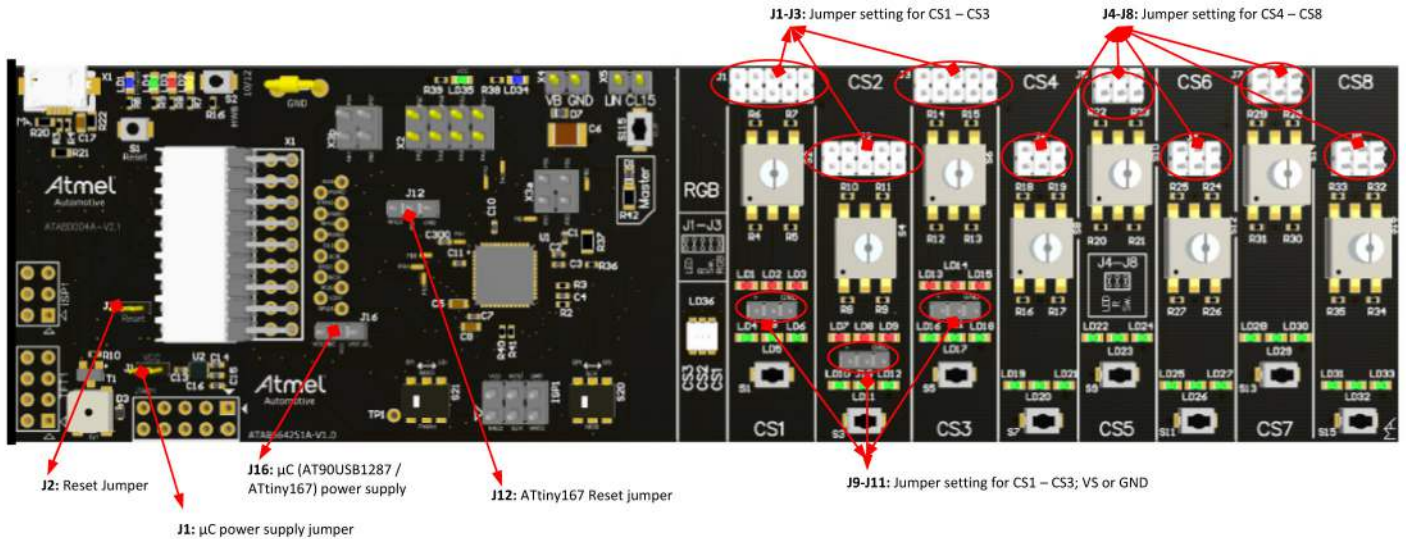

### 3.4.1 Jumper VCC - J1 (PC Interface Board)

There are three different ways to supply the microcontroller:

- Directly from the USB bus (5V supply) (jumper between 2 and 3)
- Via an on-board voltage regulator (3.3V supply) (jumper between 1 and 2) or
- Via the voltage regulator of the Atmel ATA664251 device (5V); jumper JP1 should be left unconnected and jumper JP16 should be set (left side).

By default, this jumper is set connecting the microcontroller to the USB bus supply. Changing the position of this jumper causes the microcontroller to be supplied via the on-board 3.3V voltage regulator.

To supply the microcontroller (AT90USB1287) from the voltage regulator of the Atmel ATA664251 device, remove this jumper and set jumper J16 (left side).

### 3.4.2 Jumper Reset - J2 (PC Interface Board)

By default, this jumper is set connecting the NRES output of the LIN SBC and PB6 input of the microcontroller. If desired or needed, or when simply changing the position of this jumper, the NRES could be connected to the reset input of the microcontroller. This means the microcontroller is reset in the event of watchdog failure or undervoltage at the voltage regulator output. It is helpful to leave the jumper in the default position for testing purposes, debugging, etc.

### 3.4.3 Jumper Reset - J12 (Atmel ATAB664251A Board)

By default, this jumper is set with the NRES output of the Atmel ATtiny167 and GND connected, thus holding the microcontroller inside the Atmel ATA664251 device in reset. In this case the SBC is controlled from GUI via the AT90USB1287 (on the PC interface board). To enable the ATtiny167 move this jumper to the left position or leave it open and make sure that the jumper J16 is also set in the left position.

Setting the jumper J12 in the left position connects the reset pin of the Atmel ATtiny167 with the NRES pin of the SBC. This means the ATtiny167 is reset in the event of watchdog failure or undervoltage at the voltage regulator output. It is helpful to leave the jumper open for testing purposes, debugging, etc.



### 3.4.4 Jumper SBC VCC - J16 (Atmel ATAB664251A Board)

By default, this jumper is not set and the microcontroller (AT90USB1287) is supplied either from the USB or from 3.3V external voltage regulator. To supply the microcontroller (AT90USB1287) via the voltage regulator of the Atmel ATA664251 this jumper has to be set on the left side and the jumper J1 (PC interface board) has to be removed.

Setting this jumper on the right side the Atmel ATtiny167 within the Atmel ATA664251 device powers it. In this case please make sure that neither the jumper J12 is set to the right side (GND) nor the PC interface board is plugged to the ATAB664251A board.

### 3.4.5 Jumper Settings for the CSx Ports (Atmel ATAB664251A Board)

The I/Os pins are intended for contact monitoring and/or constant current sourcing. For maximum flexibility there are various components that can be easily connected to the HV I/O ports. The following sections provide a detailed description of how the CSx port hardware can be configured.

#### 3.4.5.1 Jumpers of CS1...3

##### Jumper JP1...3

With the jumper header JP1...3 the user can select whether an RGB LED, three simple LEDs (connected in series), rotary switch, or a push button is connected to the respective CSx port.

Figure 3-9. Jumpers JP1...3

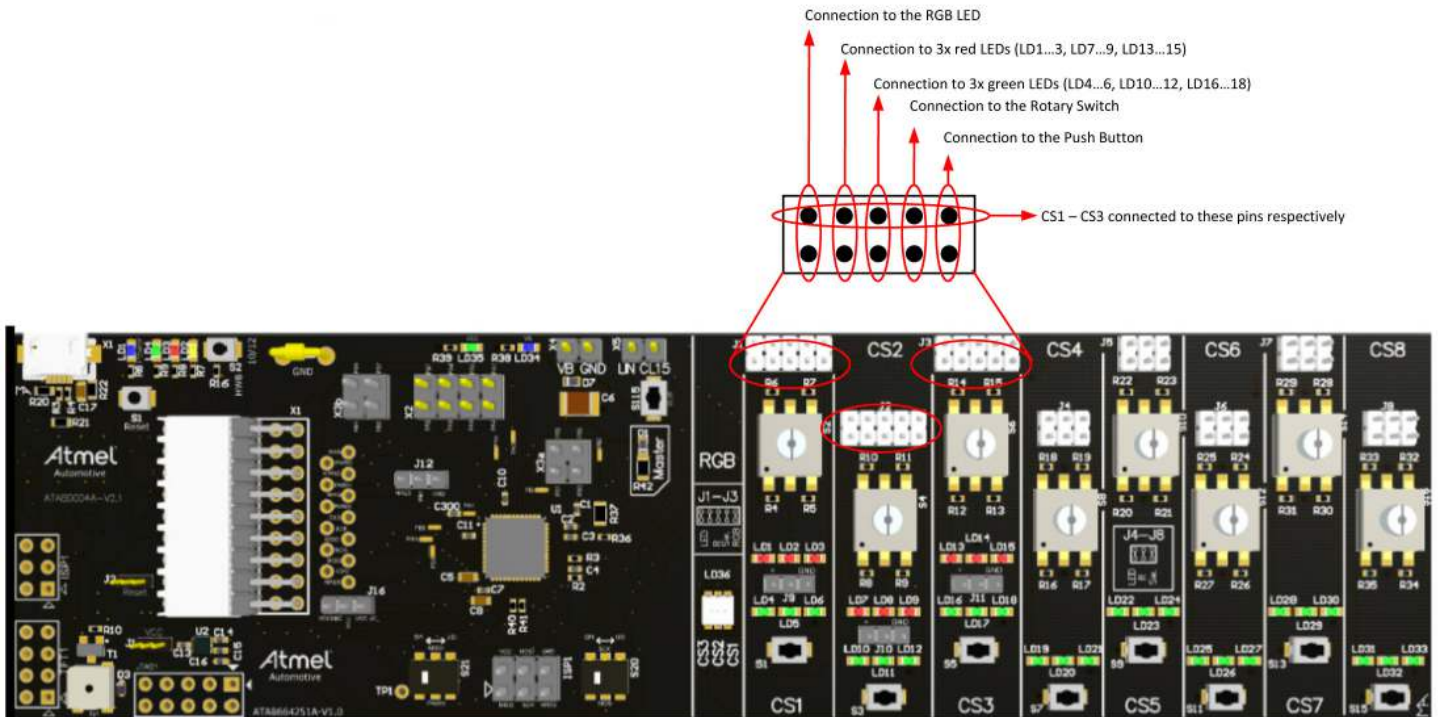

By default, this jumper is set so that the CS1...3 ports are connected to the three simple LEDs (red) - LD1...3, LD7...9 and LD13...15. Those LEDs are hardwired to VBAT so that the LEDs are turned on when one or all of the CS1...3 ports are configured as low-side and are enabled.

For demonstration purposes a second jumper (in addition to the default jumper) could be set, connecting the three green LEDs, showing that by only changing one bit the CS1...3 ports can be configured as high-side or low-side. In the case the supply voltage has to be lower than 10V (see Figure 8-2 on page 46).

If customer-specific circuitry needs to be connected to one or all of the CS1...3 ports, the jumper has to be disconnected and the customer circuitry can then be connected to one of the pins on the upper side of the pin headers PJ1...3.

## Jumper JP9...JP11

The I/Os pins CS1 to CS3 can be configured either as current sources (such as for switches toward ground) or as current sinks (such as for switches toward battery). With the jumpers JP9...11 the user can specify if the particular CSx port should be connected to ground or the VBAT. By default, these jumpers are set connecting the CS1...3 ports with VBAT.

### 3.4.5.2 Jumper of CS4...8 - JP4...8

With the jumper header JP4...8 the user can select whether three simple LEDs (connected in series), a rotary switch, or a push button is connected to a given CSx port. By default, this jumper is set so that the CS4...8 ports are connected to the three simple LEDs (green) - LD19...33.

If customer-specific circuitry needs to be connected to one or all of the CS4...8 ports, the jumper has to be disconnected and the customer circuitry can then be connected to one of the pins on the upper side of the pin headers PJ4...8.

Figure 3-10. Jumpers JP4...8

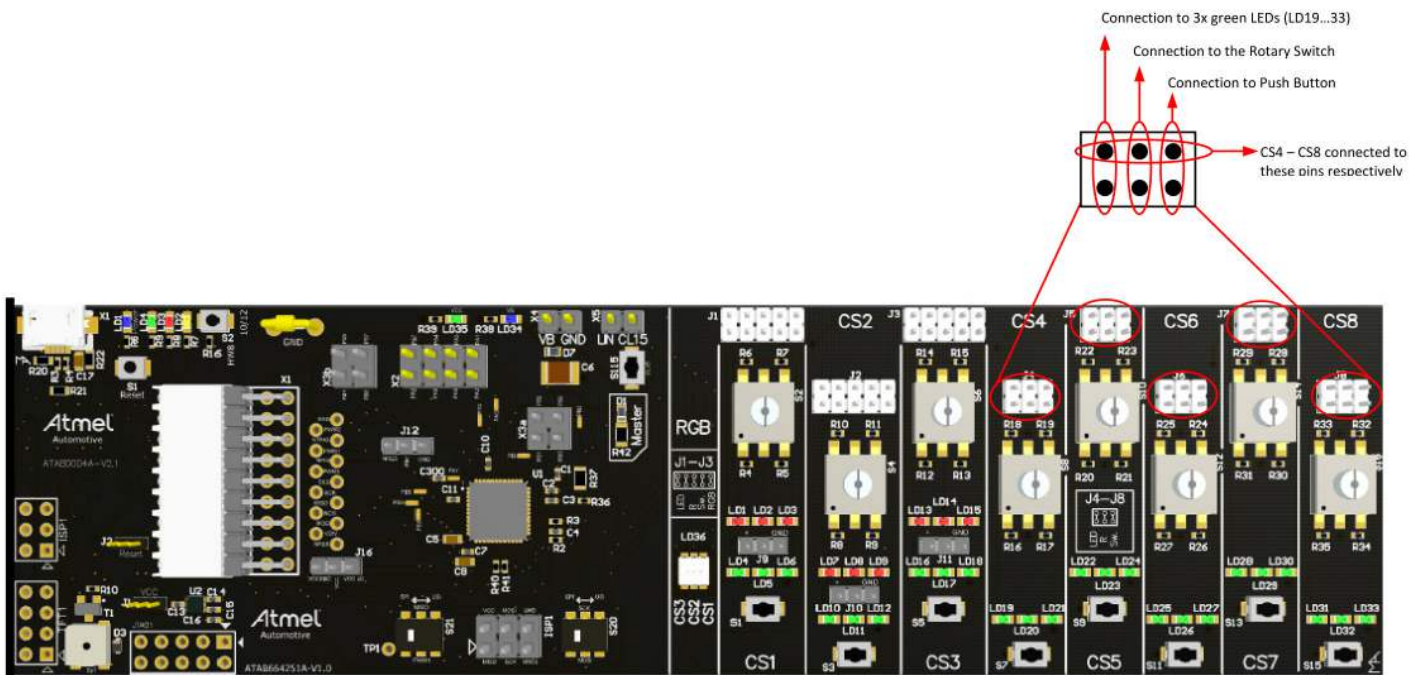

## 3.5 LEDs Description

Figure 3-11. LEDs on the Atmel ATAK43001-V1 Kit

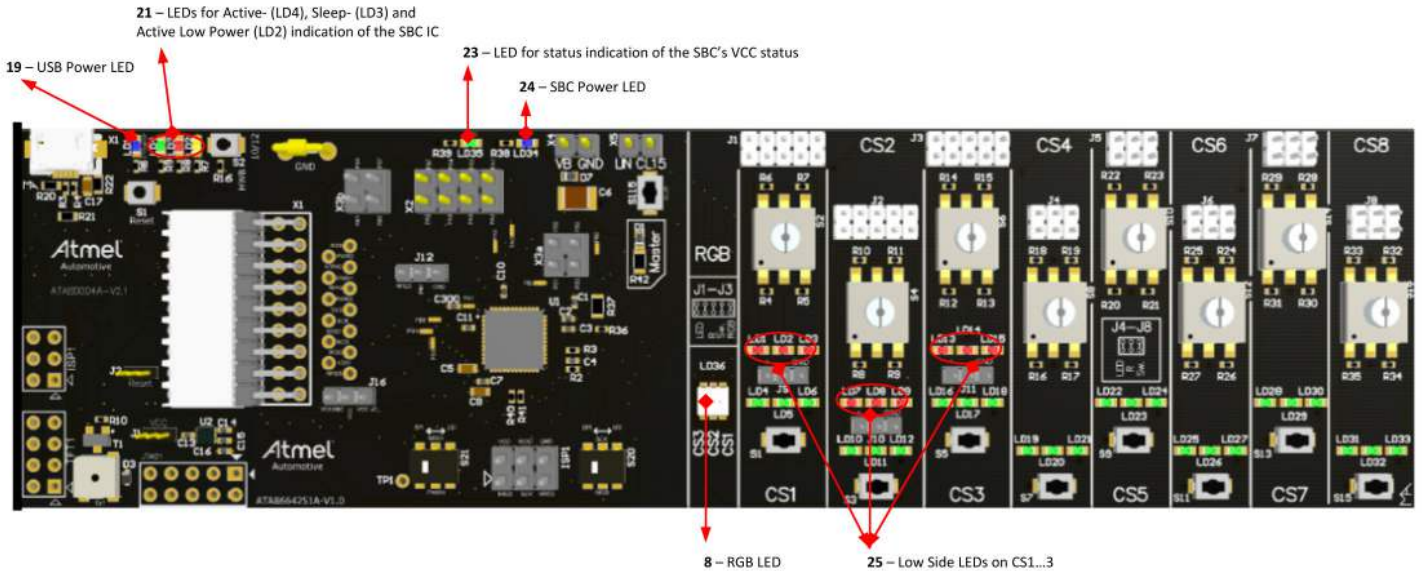

### 3.5.1 Power LED (PC Interface Board)

The blue USB power LED is connected directly to the VCC pin of the USB connector (see [Figure 3-11](#), reference point 19). The SBC power LED is always lit when power is available at the USB connector.

### 3.5.2 Power LED (Atmel ATAB664251A Board)

The blue SBC power LED is connected directly to the VS pin of the Atmel ATAB664251 device (see [Figure 3-11](#), reference point 24). The SBC power LED is always lit when power is available at the VBAT and GND connector (reference point 1). For current consumption measuring purposes the SBC power LED and the VCC SBC LED might have to be disabled. To do so, the resistors R38 and R39 have to be desoldered.

### 3.5.3 Mode Status LEDs (PC Interface Board)

There are 3 LEDs (see [Figure 3-11](#), reference point 21) on the PC interface board. The preprogrammed firmware in the Atmel AT90USB1287 uses these 3 LEDs to display the current mode of the Atmel ATAB664251:

- LD4 (green) - active mode
- LD3 (red) - sleep mode
- LD2 (yellow) - active low-power mode

These 3 LEDs can be used for any indication or debug purposes.

### 3.5.4 VCC SBC LED (Atmel ATAB664251A Board)

The green VCC SBC LED on the Atmel ATAB664251 board is connected directly to the VCC pin of the Atmel ATAB664251 device (see [Figure 3-11](#), reference point 19). This LED is always lit when the Atmel ATAB664251 is in active mode. The voltage regulator of the Atmel ATAB664251 device is only on in active mode; in all other modes it is off.

### 3.5.5 RGB LED (Atmel ATAB664251A Board)

An RGB LED is mounted on the Atmel ATA664251 board to demonstrate that the Atmel ATA664251 is capable of driving RGB LEDs. The RGB LED is connected via jumpers J1...J3 to the CSx ports as follows:

- CS1 - blue
- CS2 - red
- CS3 - green

The RGB LED is hardwired to GND. Therefore, when using the RGB LED (see [Section “Jumper JP1...3” on page 25](#) for correct jumper settings), the CS1...3 ports have to be high-side configured. The RGB LED can be permanently driven with the selected constant current (see [Section 3.6.6 “Changing the Current Level of the Current Sources” on page 31](#)) from the CS1...3 ports or with PWM signals fed on the PWM1...3 pins of the Atmel ATA664251 device (for more information, see [Section 5. “Atmel ATA664251 Demo GUI Description” on page 33](#) and the Atmel ATA664251 datasheet).

### 3.5.6 Low-Side LEDs (Atmel ATAB664251A Board)

The red LEDs LD1...3, LD7...9 and LD13...15 are hardwired to VBAT and via the jumpers JP1...JP3 to the CS1...3 ports of the Atmel ATA664251 device.

When one or all of the CS1...3 ports is/are configured as low-side and enabled, and the jumpers JP1...3 are set so that the red LEDs are connected to the CS1...3 ports (see [Section “Jumper JP1...3” on page 25](#) for correct jumper settings), then the red LEDs are lit.

### 3.5.7 High-Side LEDs (Atmel ATAB664251A Board)

The green LEDs LD4...6, LD10...12 and LD16...33 are hardwired to VBAT and via the jumpers JP1...JP8 to all CS1...8 ports of the Atmel ATA664251 device.

When one or all of the CS1...8 ports is/are enabled (CS1...3 have to be configured as low-side) and the jumpers JP1...8 are set so that the green LEDs are connected to the CS1...8 ports (see [Section “Jumper JP1...3” on page 25](#) and [Section 3.4.5.2 “Jumper of CS4...8 - JP4...8” on page 26](#) for correct jumper settings), then the green LEDs are lit.

## 3.6 Other Components

The development board for the Atmel ATA664251 comes with some additional components which can be replaced in order to adapt the LIN node to user-specific requirements. These components are shown and described in the following sections.

### 3.6.1 Push Buttons (Atmel ATAB664251A Board)

There are eight push buttons on the Atmel ATA664251 board demonstrating the switch scanning/monitoring capability of the Atmel ATA664251.

The push buttons S1...3 can be connected to GND or VBAT via the jumpers JP9...11. The push buttons 4...8 are hardwired to GND.

All 8 push buttons are connected to the CS1...8 ports via the jumpers JP1...8 (see [Section “Jumper JP1...3” on page 25](#) and [Section 3.4.5.2 “Jumper of CS4...8 - JP4...8” on page 26](#) for correct jumper settings).

### 3.6.2 Rotary Switches (Atmel ATAB664251A Board)

Eight rotary switches are mounted on the Atmel ATAB664251A board to simulate coded switches. The rotary switches S can be connected to GND or VBAT via the jumpers JP9...11. The rotary switches S10, S12, S14, and S16 are hardwired to GND.

All eight rotary switches are connected to the CS1...8 ports via the jumpers JP1...8 (see [Section "Jumper JP1...3" on page 25](#) and [Section 3.4.5.2 "Jumper of CS4...8 - JP4...8" on page 26](#) for correct jumper settings).

Figure 3-12. Rotary Switches S2, S4, and S6

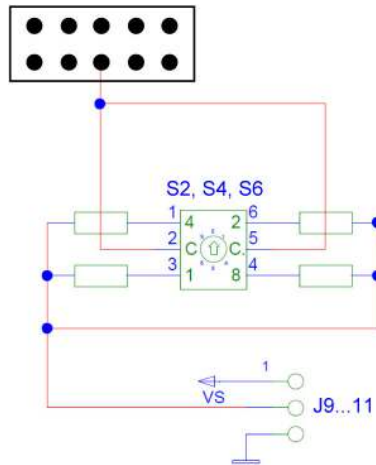

Figure 3-13. Rotary Switches S10, S12, S14, and S16

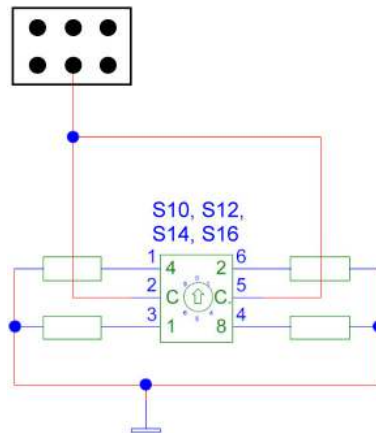

Table 3-4. Coding of the Rotary Switches

Position	0	1	2	3	4	5	6	7	8	9
Code	8								X	X
	4					X	X	X	X	
	2			X	X			X	X	
	1		X		X				X	X

When one or all of the CS1...8 ports is/are enabled and the jumpers JP1...8 are set so that the rotary switches are connected to the CS1...8 ports (see Section "Jumper JP1...3" on page 25 and Section 3.4.5.2 "Jumper of CS4...8 - JP4...8" on page 26 for correct jumper settings), a different voltage value resulting from the CSx output current, dependent on the position of the rotary switch, can be measured (and displayed in the GUI) on the VDIV pin (see also Section 5.6 "Voltage Divider Section" on page 38).

### 3.6.3 Configuring the Atmel ATA43001-V1 Kit as a Master or a Slave Node

Both the LIN2.0 and LIN2.1 specifications specify that the master node in a LIN network has to be set up as shown below.

Figure 3-14. External Circuitry for a LIN Master Node

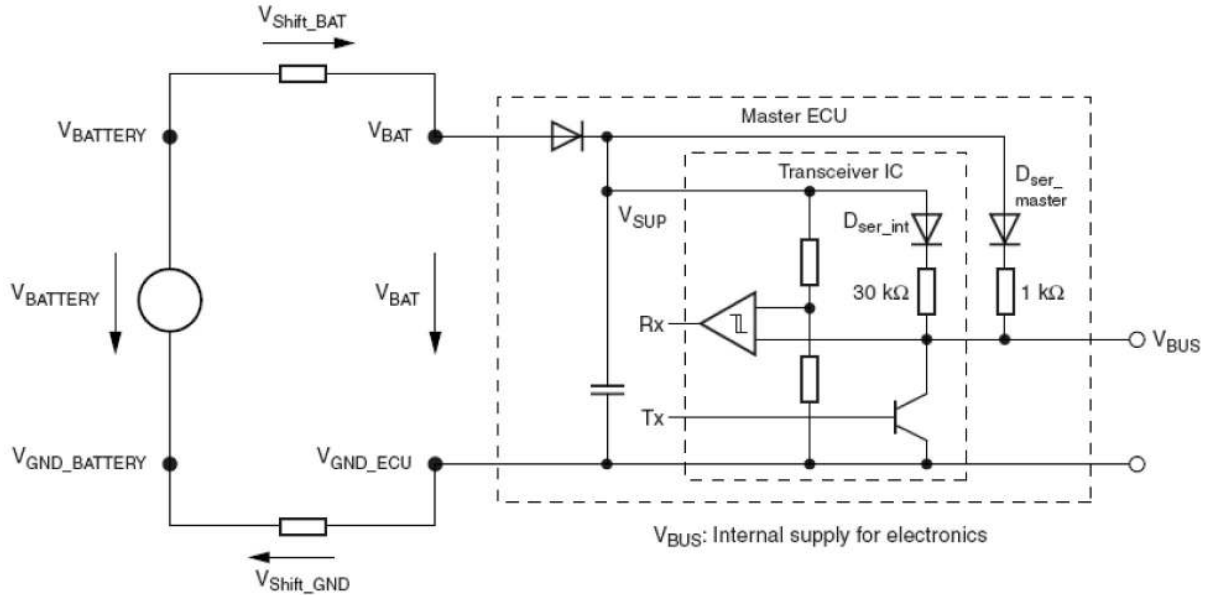

The difference between a master node and a slave node with regard to the hardware is the additional diode  $D_{ser\_master}$  together with a serial 1kΩ pull-up resistor between  $V_{sup}$  and the LIN line. The two components D1 and R42 on the ATA66B4251A board required for LIN master applications are shown in Figure 3-15.

Figure 3-15. The Diode and Resistor Required for LIN Master Applications

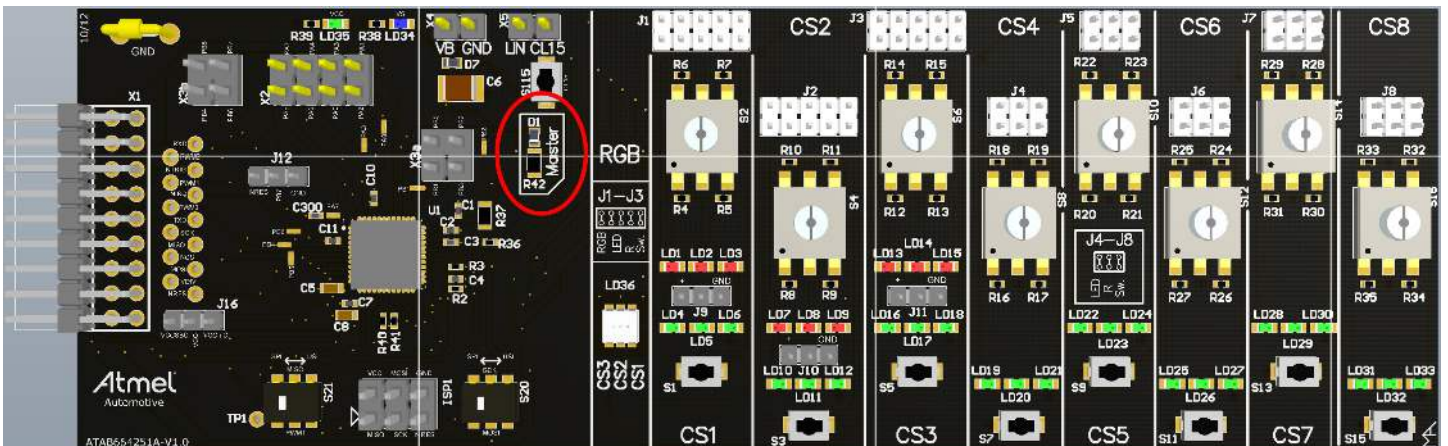

### 3.6.4 Generating a Local Wake-Up on CL15

A positive edge at pin CL15 followed by a high-voltage level for a given time period ( $> t_{CL15deb}$ ) results in a local wake-up request and the device switches to active mode. The debounce time ensures that no transients at CL15 create a wake-up.

In order to show this function easily a switch is implemented between the CL15 pin and VS. When the device is in sleep mode, pressing the S115 switch generates a wake-up pulse. The local wake-up request is indicated by a low level at the NIRQ pin, generating an interrupt for the microcontroller, which is displayed in the GUI.

Figure 3-16. Button for Local Wake-Up on CL15

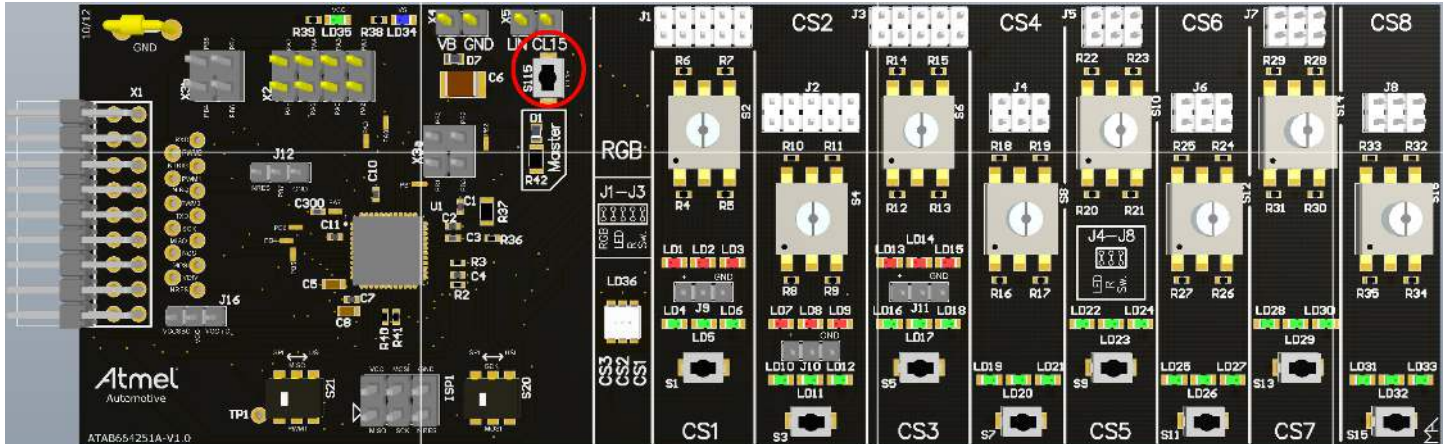

### 3.6.5 Changing the Watchdog Timings

On the Atmel ATA66B4251A board, the watchdog timing is generated by default with the help of the 51kΩ resistor R2 connected between the WD\_OSC pin and ground. In order to change these timings, the resistor R2 has to be changed.

A description of how the R2 resistor influences the watchdog timing can be found in [Section 5.7 “Watchdog Section” on page 39](#) (NTRIG, WD\_OSC, and NRES) and in the Atmel ATA664251 datasheet.

### 3.6.6 Changing the Current Level of the Current Sources

The current sources are available in active mode. They deliver a current level derived from a reference value measured at the IREF pin. This pin is voltage-stabilized ( $V_{IREF} = 1.23V$  typ.) so that the reference current is directly dependent on the externally applied resistor (R3) connected between the IREF pin and ground. The resulting current at the CSx- pins is  $(1.23V/R_{Iref}) \times r_{ICS}$ . By default, a 12kΩ resistor is mounted between IREF and GND; therefore the resulting current at the CSx pins is 10mA (assumed  $IMUL = '0' \Rightarrow r_{ICS\_H} = 100$ ).

Both a missing and a short-circuited resistor are detected. In this case, an internally generated reference current  $I_{IREFb}$  is used instead to maintain fail-safe functionality.

### 3.6.7 Using the ATAB664251A Board Stand-Alone

The Atmel ATA664251 kit allows users to learn more about Atmel ATA664251 device features by using the demo GUI but also to build their own applications and write own software using the kit.

Only a few steps are needed to prepare the kit before creating your own applications. First, disconnect the PC interface board from the ATAB664251A board, then remove the J12 jumper (for debug and test purposes it should be left open) and set the J16 jumper to the right side. Now after powering up the board the Atmel ATA664251 (the ATtiny167 and the SBC) device is ready for use.

The Atmel ATtiny167 can be programmed and debugged with an appropriate programming tool via the ISP1 connector.

For applications where the 3x different PWM signals have to be generated to control the CS1...8 HV I/O ports (for example, RGB LED control), the Atmel ATtiny167 and the SBC have to be interconnected in a different way because the timers of the Atmel ATtiny167 are available on certain I/O pins only. The SPI pins (MISO, MOSI, and SCK) have an alternate function which is needed to generate PWM signal. That is why instead of the SPI the USI interface has to be used for communicating with the SBC. Two SMD DIP switches are included on the board to facilitate quick rerouting of the MISO, MOSI, and SCK SBC lines to the corresponding Atmel ATtiny167 I/O pins.

## 4. Programming and Debugging

The easiest way to program and to debug the Atmel® AT90USB1287 is to use the Atmel Studio environment together with the STK500/600 or the JTAG-ICE MkII from Atmel. Atmel Studio is an integrated development platform (IDP) for writing and debugging AVR applications in Windows® 9x/Me/NT/2000/XP/7 environments. Atmel Studio provides a project management tool, source file editor, chip simulator, and in-circuit emulator interface for the powerful AVR 8-bit RISC family of microcontrollers.

### 4.1 Programming

Connect the selected hardware (STK500/600 or JTAG-ICE MkII) to the ISP or JTAG header of the ATAB0004A board respectively. Pin “1” is marked with two small triangles on the board. In the Atmel Studio select the Atmel AT90USB1287. For more information about using the STK500/600, the JTAG-ICE MkII, or the Atmel Studio, see the relevant documentation available on the Internet.

### 4.2 Debugging

Combined with Atmel Studio, the JTAGICE MkII can perform on-chip debugging on all AVR 8-bit RISC microcontrollers with a JTAG or debugWIRE interface. The Atmel AT90USB1287 comes with a debugWIRE interface so only a minimum of three wires is required for communication between the JTAGICE MkII and the board. These signals are RESET, VCC, and GND.

The debugWIRE on-chip debug system uses a one-wire bidirectional interface to control the program flow, execute AVR instructions in the CPU, and to program the different non-volatile memories. For debugging via debugWIRE, the reset line is used and the NRES jumper has to be removed because the JTAG ICE mkII requires exclusive access to this line.

For more detailed information about debugging via the debugWIRE interface, see the relevant documentation available on the Internet.



## 5. Atmel ATA664251 Demo GUI Description

The Atmel® ATA664251 demo GUI (graphical user interface) is a software tool for configuring and demonstrating the Atmel ATA664251 device using the Atmel ATAK43001-V1 kit.

The Atmel ATA664251 demo GUI was designed to minimize the learning curve for using the Atmel ATA664251 device in the user application. It is divided into 11 main sections:

- SBC: general SBC settings and mode status
- Current SBC Status: displays the current SBC status (16-bit status register)
- Command Builder: builds a specific command and sends to the SBC
- SPI-Log-Window: the complete SPI communication is logged in here
- I/O Ports: configuration settings for all high-voltage I/O ports
- Voltage Divider: voltage divider settings and display of the currently measured voltage
- Watchdog: watchdog settings
- LIN: LIN interface settings
- PWMx: PWM test settings for the three different PWM inputs

Figure 5-1. Atmel ATA664251 Demo GUI



In the following section the Atmel ATA664251 demo GUI sections are described in detail, including some examples showing how to configure the Atmel ATA664251 device.

## 5.1 SBC Section

After executing the Atmel ATA6641xx\_Demo.exe file, the Atmel ATA664251 is automatically set to active low-power mode. This is indicated in the GUI: [Figure 5-2](#) (yellow LED - ActiveLP is ON) and on the PC interface board (LED - LD2 is ON (reference point 21)) as well (please see [Figure 2-12 on page 13](#)).

In this mode, only the VCC voltage regulator is active and can therefore supply the application's microcontroller. All other functions of the Atmel ATA664251 are disabled in the configuration register or inhibited by the PWM pins for the CSx pin current sources. This reduces the current consumption of the chip itself to a low-power range typically below 50µA. Note that this is only valid if the chip select input of the SPI, NCS, is also kept at a high level. If it is pulled to ground, SPI communication is enabled, causing higher current consumption.

The Atmel ATA664251 can easily be set to active mode (simply press the "Active Mode" button) with all peripherals/functions enabled, or set to sleep mode (simply press the "Go to Sleep" button), which switches off all peripherals, i.e., the LIN transceiver, the watchdog, the voltage dividers, the switch interface unit, and the VCC voltage regulator. The overall supply current on the VS pin is then reduced to a minimum (typ. 8µA). In sleep mode the GUI is also disabled and no changes can be made as long as the device is in sleep mode.

Two wake-up mechanisms are possible for leaving the sleep mode again: wake-up via LIN and wake-up via CL15. A wake-up via CL15 is easily generated by pressing the S115 switch.

The SPI data rate can be modified; it is 4MHz by default.

**Figure 5-2. SBC Section**



## 5.2 Current SBC Status Section

[Section 5.2 "Current SBC Status Section" on page 34](#) indicates the status of the Atmel ATA664251. The 16 bits of the status register, NRES, and NIRQ are displayed where the 16 status bits are updated after a new SPI command.

This means, for example, that if you enable the watchdog with an SPI command, the status "Watchdog Active" is not reported in this data transmission but in the next one.

Depending on the setting of the VDIVE bit, the bits 15 to 12 in the status register have a different meaning:

- VDIVE=0: bits 15 to 12 show the overtemperature status of different peripherals.

**Figure 5-3. Current SBC Status Section VDIVE=0**



- VDIVE=1: bits 15 to 12 show the selected source for the voltage monitor (VBATT or CS1...8).

**Figure 5-4. Current SBC Status Section VDIVE=1**



For more information on the single bits, see Table 7-4 in the Atmel ATA664251 datasheet.

### 5.3 Command Builder Section

Section 5.3 “Command Builder Section” on page 35 gives the user the ability to create and send any command to the Atmel ATA664251 device. There are two possible ways to create a command: either by selecting the desired bits or just typing a sixteen-bit value into the “Data to Send” field (press “Enter” to activate the typed value).

In order to avoid false watchdog disabling, the configuration bit (WDD) needs to be written twice. Therefore two consecutive SPI words are sent in order to alter the WDD bit to ‘1’.

Depending on the setting of the CSPE bit, bit 1 in the configuration register has a different function:

- CSPE=0: bit #1 enables/disables the slope control of the CS ports

**Figure 5-5. Command Builder Section CSPE=0**



- CSPE=1: bit #1 enables interrupt from addressed switch input (CS1...8)

**Figure 5-6. Command Builder Section CSPE=1**



For more information on the single bits, see Table 7-1 in the Atmel ATA664251 datasheet.

## 5.4 SPI Log Window Section

The complete communication to and from the Atmel ATA664251 device is logged into the “SPI Log Window.” If a specific command has to be resent, just copy and paste it into the “Data to Send” field in [Figure 5-7](#) and press “Send.”

**Figure 5-7. Command Builder Section**

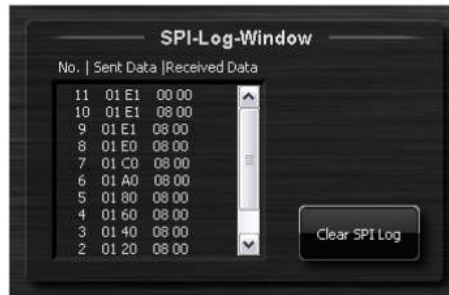

## 5.5 I/O Ports Section

A total of eight high-side current sources with high-voltage comparators and voltage dividers are available. Note that three of them (CS1, CS2, and CS3) can also be switched to low-side current sinks. All eight high-voltage I/O ports can be configured separately with the three or four configuration bits:

- CSE: Enable/disable addressed current source (CS1...CS8)
- CSC: Control of addressed current source (CS1...CS8) - controlled either by PWM input or internally by CSE
- CSIE: Enable/disable from interrupt from addressed switch input (CS1...CS8)
- CSSSM: Switch between source/sink mode (CS1...CS3 only)

The output current level can be divided by 2 using the IMUL bit. With the default setting of IMUL = 'x100' the resulting current at the CSx- pins is  $(1.23V/R3) \times 100 = 10\text{mA}$  (default value for R3 is 12k $\Omega$ ).

The CSSCD bit is the one common control bit for all current sources. With this bit, the slope control of all eight sources can be disabled. By default, the slope control is activated and all currents are switched on and off smoothly. When setting this bit to '1' the current sources are enabled and disabled without transition times. In order to change the configuration of a certain current source via SPI, it must be addressed and the current source programming CSPE bit must be set to '1' (in the GUI this is done automatically).

**Figure 5-8. I/O Port Section**



**Example 1:** Enabling a particular current source and controlling it via the CSC bit or via the PWM1 input:

In this example, the CS1 port is connected to the green/red LEDs (the following is valid for CS1...8). Set the J1 jumper to the second position (counted from left to right). Then all that has to be done in the GUI is to select the corresponding CSE bit and CSC bit (for internal control) and press the “Configure CS1” button. Now the CS1 port is enabled as indicated by illuminated green LEDs and configured as the high-side current source and controlled by the internal logic.

The control of the current source can be easily changed to be PWM-controlled by deselecting the CSC bit and pressing the “Configure CS1” button again; this turns off the LEDs. The PWM1 pin is assigned to the CS1 port. By default the PWM mode in the GUI is set to static-low, meaning the PWM1 input is actively kept to low. To turn on the LED the PWM must be changed to static-high, which is equal to CSC=1, or “pulsed” selected where the signal with default period (1ms) and pulse width (100µs) is to be generated on the PWM1 pin. To adjust the brightness of the LEDs, simply change the period and the pulse width as desired.

To configure the CS1 port as the low-side current source (this is only valid for CS1...3), simply set the CS5SM bit and set the jumper at the very first position on the left side.

**Example 2:** Connecting a switch to a specific current source (Contact Monitoring):

Now the CS1 port is connected to a tactile switch (S1) (the following is valid for CS1...8). Change the jumper setting of J1 to the second position from the right, with jumper J9 connecting the middle and right pin (the tactile switch is connected toward GND). Configure and enable a high-side current source for the CS1 port (set CSE and CSC bits and press “Configure CS1” button). From the voltage divider section, select the CS1 port as ADC source and activate continuous voltage measurement. By pressing the tactile switch (S1) the measured voltage in the voltage divider section changes to 0V because the CS1 port is then (when S1 is pressed) connected directly to GND. This status change is also indicated with the CS1CS bit in the status register. Please note that the status bits in the “Current SBC Status” section are updated only after an SPI command has been sent.

Now the interrupt from the CS1 port is enabled and the CS1 port to be PWM1-controlled is configured. To do this, set the CSIE bit and deselect the CSC bit. Finally, press the “Configure CS1” button and set the pulsed mode in the PWM1 section.

Now the output state of the HV comparator is sampled with each falling edge of the PWM<sub>y</sub> or CSC signal. As soon as the sampled state changes (S1 pressed), an interrupt request is generated and reported by a low level on the NIRQ pin (automatically displayed in the “Current SBC Status” section). Please bear in mind that the NIRQ pin remains at ground until the end of the next SPI command.

The same can be done when the CS1 port is configured as low-side current source (enable the CSSSM bit and change the setting of the J9 jumper to the left) (this is only valid for CS1...3).

## 5.6 Voltage Divider Section

The VDIV pin provides a low-voltage signal for the microcontroller’s ADC which is linearly dependent on the input voltage. It is sourced either by the VBATT pin or one of the switch input pins CS1 to CS8. The divider ratio of the measured input voltage for the Atmel ATA664251 is 1:4. This results in maximum output voltages on the VDIV pin when reaching 20V at the input.

The voltage on this pin is actively clamped to VCC if the input value would lead to higher values.

**Figure 5-9. Voltage Divider Section**



The displayed voltage value in the voltage divider section is the result of the following equation:

$$\text{Input\_Voltage} = (\text{Divider\_Ratio} \times \text{VDIV\_Value} \times \text{Reference\_Voltage})/1023$$

- Input\_Voltage is the measured and displayed voltage.
- Divider\_Ratio is 4.
- VDIV\_Value is the measured voltage at the VDIV pin.
- Reference\_Voltage is the internal reference voltage of the microcontroller, which is dependent on the microcontroller’s supply voltage (for setting jumper J1 and J16, see [Section 3.4.1 “Jumper VCC - J1 \(PC Interface Board\)” on page 24](#) and [Section 3.4.4 “Jumper SBC VCC - J16 \(Atmel ATAB664251A Board\)” on page 25](#)).

Because the supply voltage of the microcontroller is not measured precisely, a fixed values of 5.0V for the Reference\_Voltage is used. If a more precise display of the measured voltage is desired, the real supply voltage of the microcontroller has to be measured and typed in the “Ref. Voltage” field. This value is used in the equation above to calculate the input voltage only when the



button is pressed. The input voltage can be measured continuously or at intervals.

## 5.7 Watchdog Section

The watchdog expects a trigger signal from the microcontroller at the NTRIG (negative edge) input within a time window of  $t_{wd} = t_{NTRIG}$ . The trigger signal must exceed a minimum time  $t_{trigmin} > 7\mu s$ . If a triggering signal is not received, a reset signal will be generated at output NRES. The timing basis of the watchdog is provided by the internal watchdog oscillator. Its time period,  $t_{WDosc}$ , is adjustable between 20ms and 64ms using the external resistor R2 (34k $\Omega$  ... 120k $\Omega$ , the default value is 51k $\Omega$ ). During sleep mode the watchdog is switched off to reduce current consumption.

The GUI offers the option of experimenting with trigger values (simply change the  $t_{NTRIG}$  value) or even disabling the trigger signal in order to gain a better understanding of how the watchdog works.

Figure 5-10. Watchdog Section



In order to avoid false watchdog disabling, this configuration bit (WDD) needs to be written twice. Therefore two consecutive SPI words are sent in order to alter the WDD bit to '1'.

**To disable the watchdog directly after power-up (e.g., for microcontroller programming or debugging purposes) (i.e., after external power-up or after sleep mode), the VDIV pin has to be tied to VCC until the start-up time  $t_{reset}$  of typ. 4ms has elapsed.**

The minimum time for the first watchdog pulse is required after the undervoltage reset at NRES disappears. It is defined as lead time  $t_d = 155ms$  (for more information, please see Section 10 in the Atmel ATA664251 datasheet). After wake-up from sleep mode, the lead time  $t_d$  starts with the positive edge of the NRES output.

## 5.8 LIN Section

The LIN interface of the Atmel ATA664251 device has to be activated via an SPI command. This is done with the GUI by simply pressing the "LIN Interface" button.

Figure 5-11. LIN Section

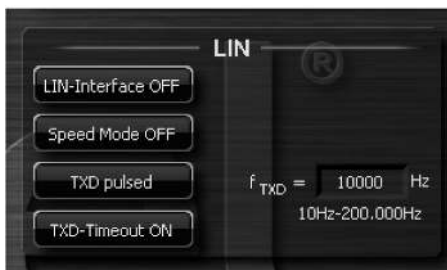

The slope control of the LIN transceiver can be switched off to achieve higher bit rates (up to 200kBit/s). Then the slope time of the LIN falling edge is  $< 2\mu s$ . The slope time of the rising edge greatly depends on the capacitive load and the pull-up resistance at the LIN line. To achieve a high bit rate Atmel recommends using a small external pull-up resistor (500 $\Omega$ ) and a small capacitor. Superior EMC performance is not guaranteed in this high-speed mode.

For test purposes a test signal (10Hz - 200kHz) can be generated at the TXD pin and if the LIN interface is enabled, the same signal can be observed at the LIN pin.

In order to achieve any long dominant state on the pin LIN (such as PWM transmission or low bit rates), the time-out function can be easily disabled by pressing the "TXD Time-Out" button.

## 5.9 PWMy Section

There are three PWM sections in the GUI where a specific PWM signal can be generated at the corresponding PWM inputs of the Atmel ATA664251 device.

**Figure 5-12. PWM Section**



The switch interface current sources can be controlled directly via the PWMy input pins, such as for pulse-width-modulated load control or for pulsed switch scanning.

The assignment of the current sources to the three PWM input pins is shown in [Table 5-1](#).

**Table 5-1. CSx Port Configuration Table**

PWM Port	CS1	CS2	CS3	CS4	CS5	CS6	CS7	CS8
PWM1	X	-	-	-	-	-	X	X
PWM2	-	X	-	-	X	X	-	-
PWM3	-	-	X	X	-	-	-	-

To enable the external control functionality of a given current source the relevant CSC bit should be disabled (please see [Section 5.5 “I/O Ports Section” on page 36](#)). External PWM signals could be applied at the PWMy input pins or the GUI could be used to generate a PWM signal on the PWMy input pins. In the PWM 1...3 sections in the GUI three independent PWM signals can be generated; just type in the desired period and pulse width and select “pulsed” as the PWM mode. The PWM 3 signal is generated by using the 8 bit timer of the AT90USB1287 (PC Interface board), therefore fine settings for the “PWM3-Pulsewidth” are not possible like for the PWM 1 and PWM 2, where 16 bit timers are used to generate the PWM pulses.



## 6. Operation Using the Default Software

### 6.1 Standalone Demonstration Quick Start User Guide

As the SiP on the Atmel® ATAB664251A-V1.0 includes an Atmel ATtiny167 AVR® 8-bit microcontroller, the Atmel ATAB664251A-V1.0 board can operate “standalone” without the PC interface board connected. The following sections describe standalone operation with the default software programmed in the Atmel AVR 8-bit microcontroller.

#### 6.1.1 Configuration for Standalone Operation

1. Disconnect the PC interface board
2. Configure the jumpers and switches
  - Jumper reset - J12 (Atmel ATAB664251A board)  
Jumper J12 controls the reset signal to the Atmel ATtiny167 microcontroller. Remove jumper J12 or set jumper J12 in left side (NRES) for standalone operation. Refer to [Section 3.4.3 “Jumper Reset - J12 \(Atmel ATAB664251A Board\)” on page 24](#) for additional information concerning this jumper.
  - Jumper SBC VCC - J16 (Atmel ATAB664251A board)  
Jumper J16 controls the supply voltage to the Atmel ATtiny167 microcontroller. Set jumper J16 to the right side (VCC microcontroller) for standalone operation. Refer to [Section 3.4.4 “Jumper SBC VCC - J16 \(Atmel ATAB664251A Board\)” on page 25](#) for additional information concerning this jumper.
  - Jumper J1 to J3  
Set jumpers J1, J2 and J3 each to the left-most position to connect the constant current source to the RGB LED (LD36).
  - Jumper J4  
Set jumpers J4 to the right-most position to connect to the push button S7.
  - Jumper J5 to J8  
Set jumpers J5, J6, J7 and J8 each to the left-most position to connect the constant current source to the green LED's (LD22 through LD33).
  - Switch S20 and S21  
Switches S20 and S21 are used to select the peripheral used for the SPI communication between the Atmel ATtiny167 microcontroller and the Atmel ATA664151 LINSBC. If both switches S20 and S21 are in the right position, the USI peripheral in the Atmel ATtiny167 microcontroller is used to communicate with the LINSBC. If both switches S20 and S21 are in the left position, the SPI peripheral in the Atmel ATtiny167 microcontroller is used to communicate with the LINSBC. For standalone operation with the default software programmed in the Atmel AVR 8-bit microcontroller, switches S20 and S21 should be set in the right position (USI).
  - Header X4  
Apply 12V power and ground to header X4.

#### 6.1.2 Standalone Demonstration Operation

After applying power to header X4, the blue power LED (LD34) and green VCC SBC LED (LD35) should be on indicating power is supplied to the Atmel ATtiny167 microcontroller. The RGB LED (LD36) should show blue, the LEDs assigned to CS5 (LD22-LD24) should flash approximately 0.5 seconds on - 0.5 seconds off, and the LEDs connected to CS6 (LD25-LD27) should be on.

After powering up, subsequent presses of the push button (S7) connected to CS4 will cycle LED's in the following manner, demonstrating the capabilities of the device to interface to switch type inputs and drive outputs:

RGB LED (LD36): RED → GREEN → WHITE → OFF → BLUE → RED → ...

LEDs connected to CS6-CS8 (LD25-LD33): Cycle through binary codes for 2 → 3 → 4 → 5 → 6 → 7 → 0 → 1 → ... (LEDs connected to CS6 represent the least significant bit of the binary code)

The LEDs connected to CS5 (LD22-LD24) should continue to blink on-off at the same rate.

## 6.2 LIN Slave Node Demonstration Quick Start User Guide

The default standalone demonstration software also includes the capability for the Atmel® ATAB664251A board to operate as a LIN slave node responding to messages from a LIN master node. Among other things, the standalone demonstration illustrates the use of the LIN SIP for ambient lighting applications by controlling the RGB LED based on messages received from a LIN master node.

### 6.2.1 Configuration for Ambient Lighting LIN Slave Node

The Atmel ATAB664251A board should be configured as described in [Section 6.1.1 “Configuration for Standalone Operation” on page 41](#). In addition, the LIN BUS from the LIN master node should be connected to header X5.

The Atmel AT32UC3C-EK evaluation kit (available separately) can be utilized as the LIN Master. Software is available from Atmel for this kit to configure it to send ambient lighting messages over the LIN bus in response to actions on the kit’s user interface, allowing the user to send different RGB values to each of several ambient lighting slave nodes. Each slave node should respond only to the ambient lighting messages directed to its slave node address.

### 6.2.2 Ambient Lighting LIN Slave Node Operation

The ambient lighting slave node address of the Atmel ATAB664251A board is selected using the push button (S7) connected to CS4. Successive presses of this push button increment the slave node addresses from 1 through 7; after address 7, a press of the push button selects an invalid slave address (meaning the board will not respond to any ambient lighting messages). A subsequent press of the push button after this starts the sequence again with a slave address of 1. The selected slave address is displayed in binary code on the LEDs connected to CS6-CS8 (LD25-LD33) with the LEDs connected to CS6 representing the least significant bit of the binary code. The invalid slave address is indicated by all the LEDs (LD25-LD33) being off.

The Atmel ATAB664251A board will respond to ambient lighting messages targeted to its slave node address, allowing the RGB LED on the board to be controlled from a LIN master node.

### 6.2.3 LIN Messages Supported in the Default Software

In addition to the LIN messages used for ambient lighting control, several other LIN messages are supported in the default software on the Atmel ATAB664251A board. These LIN messages allow for complete control of the LIN SBC features from a LIN master node.

**Table 6-1. LIN Messages**

Message	PID	Direction <sup>(1)</sup>	Data	Notes
Set SBC configuration register	0x23	Receive	2 bytes: Bit 15 to Bit 0: Configuration register	1 - The received value is transferred over SPI to the LIN SBC. 2 - Ambient lighting operation will not work properly after this message is received.
Set PWM period and duty	0x25	Receive	8 bytes: Bit 15 to Bit 0: PWM Period Bit 31 to Bit 16: PWM-1 duty cycle Bit 47 to Bit 32: PWM-2 duty cycle Bit 63 to Bit 48: PWM-3 duty cycle	Period and duty cycles are in terms of microseconds (us); 1 count = 1μs.
Set watchdog trigger period	0x26	Receive	1 byte: Bit 7 to Bit 0: Trigger period	Watchdog trigger period is in terms of milliseconds (ms); 1 count = 1 ms. A period of 0 will <b>not</b> generate a trigger.
Ambient lighting	0x2C	Receive	4 bytes: Bit 7 to Bit 0: Slave node address Bit 15 to Bit 8: Red duty cycle Bit 23 to Bit 16: Green duty cycle Bit 31 to Bit 24: Blue duty cycle	Duty cycles are scaled to 255 counts; 255 counts = 100% duty cycle.
Get SBC status register and VDIV	0x24	Transmit	4 bytes: Bit 15 – Bit 0: Status register Bit 31 – Bit 16: VDIV A/D reading	The transmitted value is the value obtained over SPI from the LIN SBC.

Note: 1. Direction is relative to the Atmel ATAB664251A board configured by default software as a LIN slave

## 6.3 Default Software Overview

The following depicts an overview of the default software programmed in the Atmel® ATtiny167 AVR® 8-bit microcontroller.

Figure 6-1. Overview of the Default Software

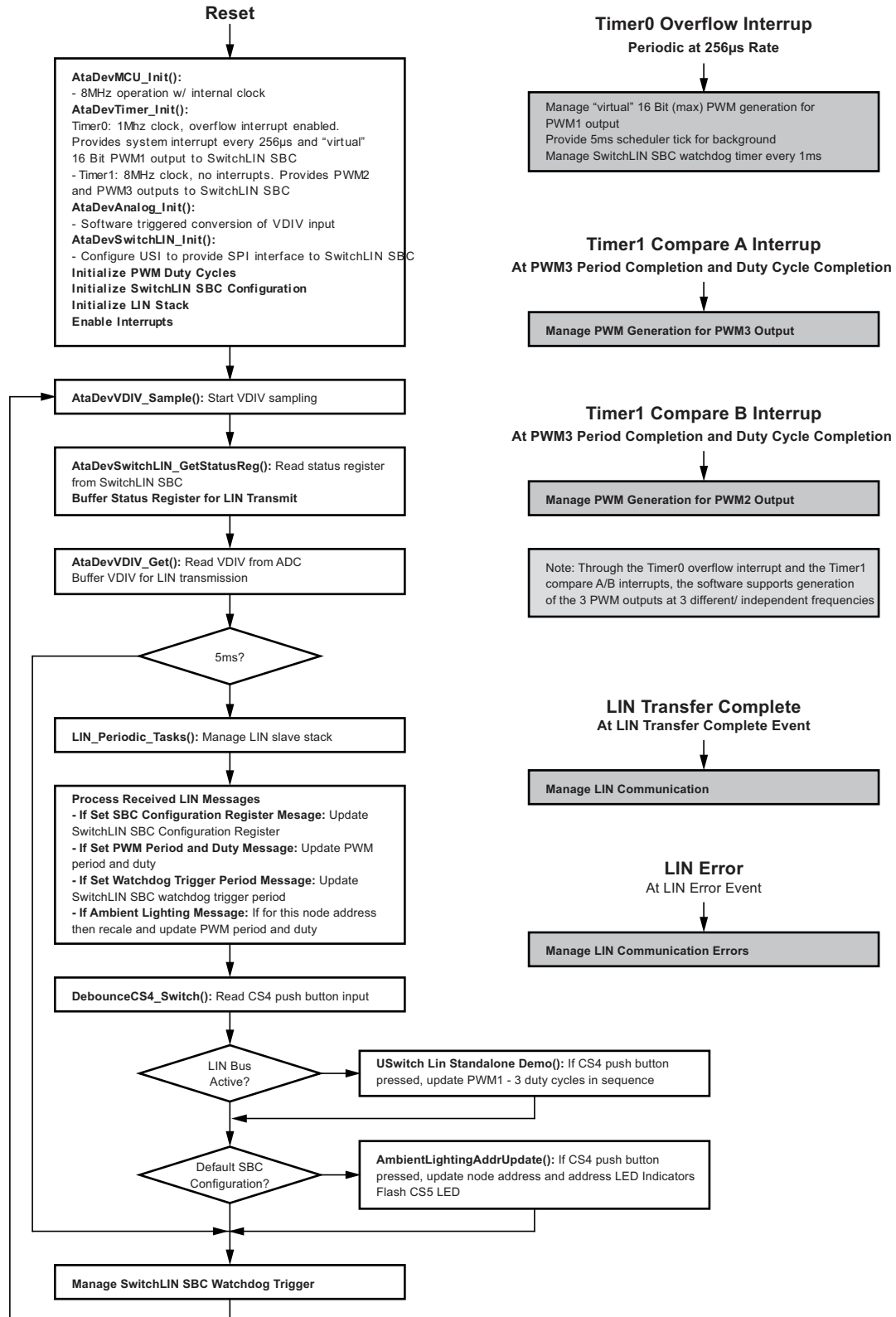

## 7. Tools

In combination with the STK500 and JTAG ICE MkII, Atmel Studio is a powerful tool for programming and debugging the AVR® microcontroller family in general.

Furthermore, Atmel® provides cost-effective software support for the development of a LIN network. These can easily be used together with the development board.

A LIN1.3 ANSI C software library for the AVR microcontroller family is available. The software library allows programming of protocol handling for LIN slave nodes. This library can be downloaded at <http://www.atmel.com/Images/doc1637.pdf>

Many OEMs demand that their suppliers use certified third-party LIN protocol stacks. To meet this requirement there are LIN2.0 as well as LIN2.1 protocol stacks available for the large number of AVR microcontrollers from Mentor Graphics®, Vector Informatik, Warwick Control Technologies, Dunasys, and from IHR.

Warwick Control Technologies offers the NETGEN configuration and autocoder tool. For testing purposes and to provide a quick start to using Atmel products, there is a limited but free version available. The demo version is available at <http://www.warwickcontrol.com/>

For more information about the certified LIN stacks, please contact the third-party suppliers directly.

## 8. Schematics of the Atmel ATAK43001-V1 Kit

Figure 8-1. Schematics of the PC Interface Board

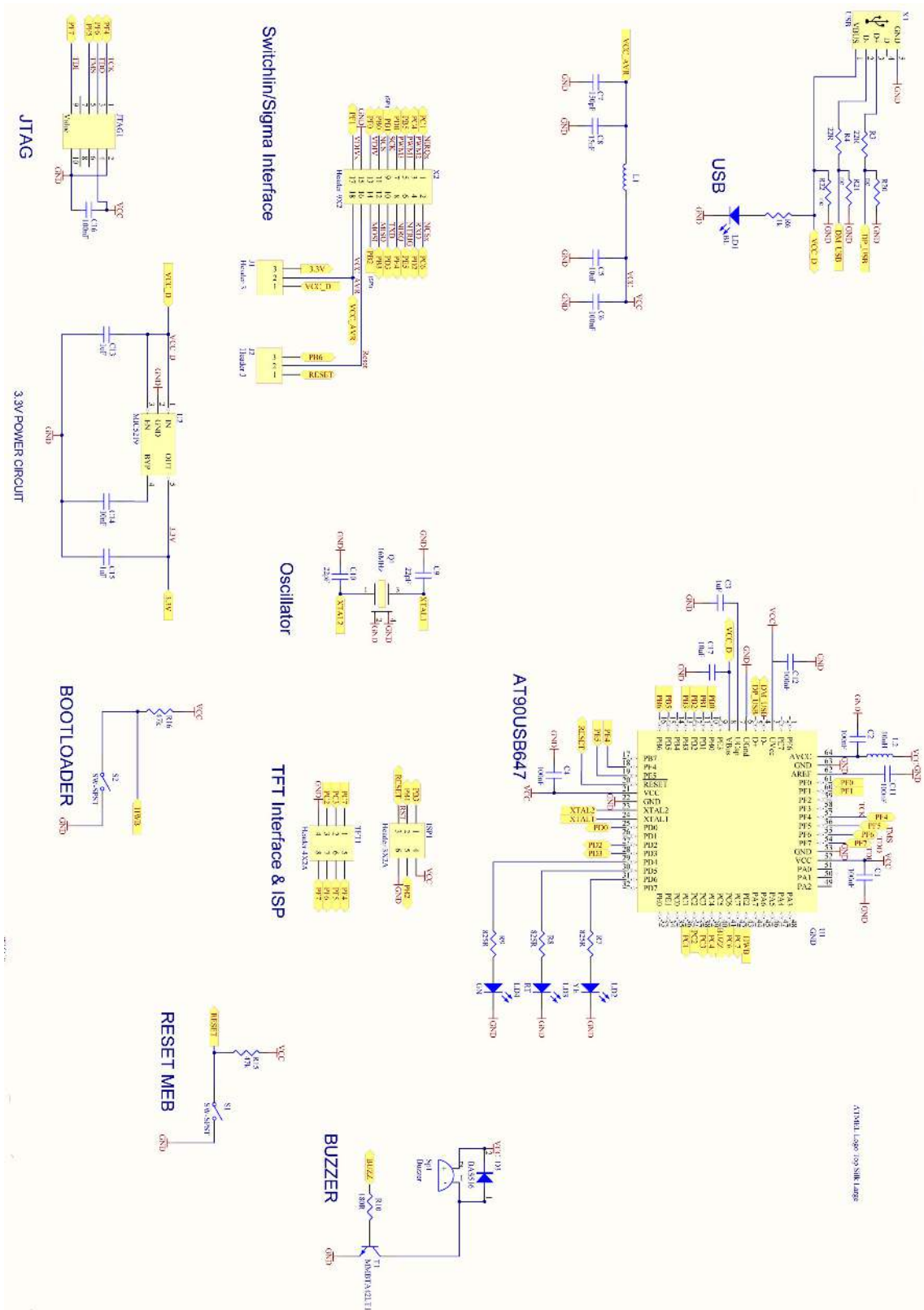
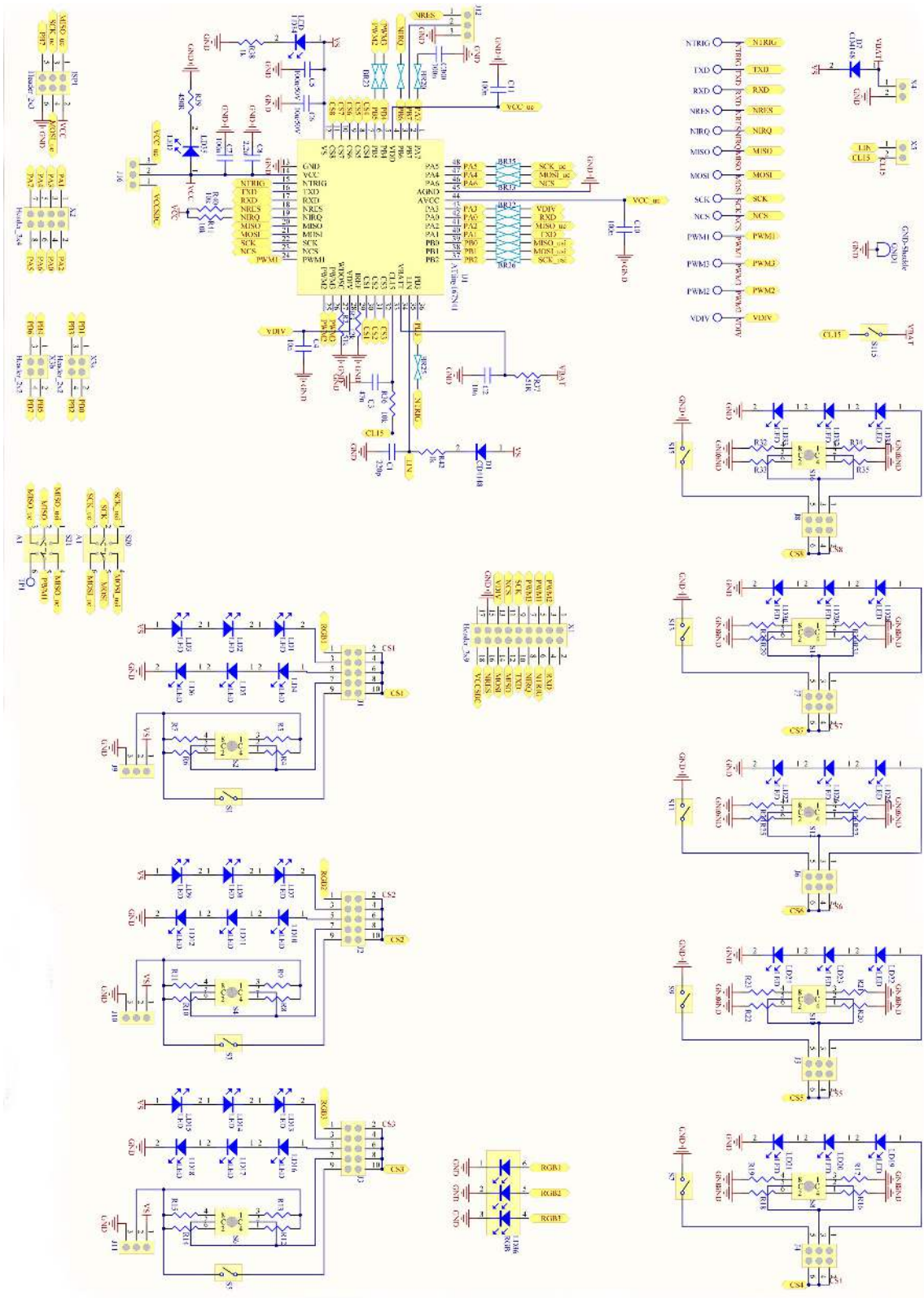

Figure 8-2. Schematics of the Atmel ATAB664251A Board



## 9. Board Layout

Figure 9-1. PC Interface Board Component Placement; Top Side, Top View

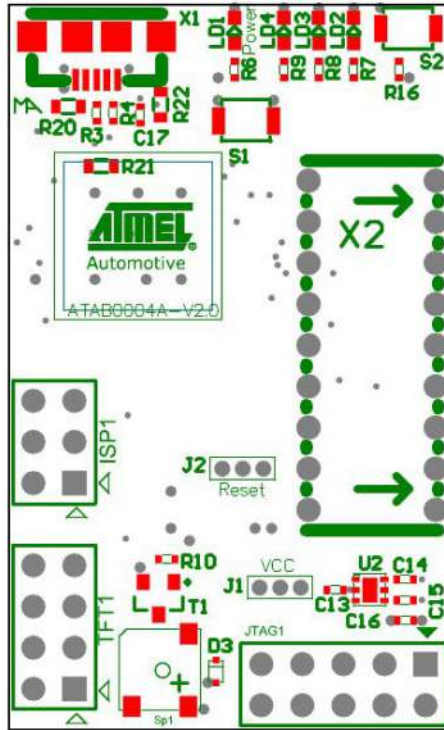

Figure 9-2. PC Interface Board Component Placement; Bottom Side, Top View (as if PCB was Transparent)

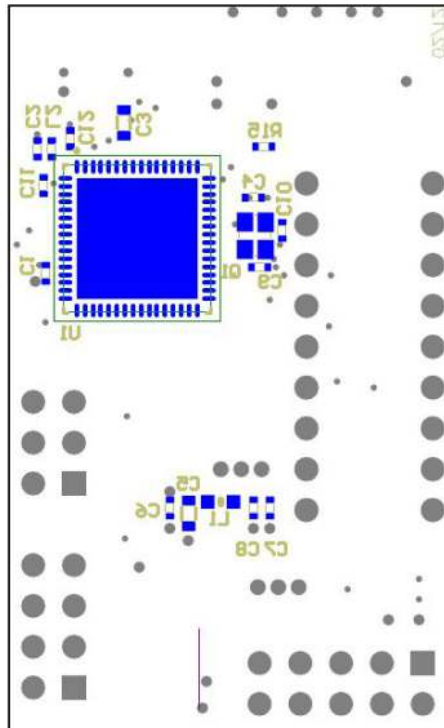

Figure 9-3. PC Interface Board; Top Side, Top View

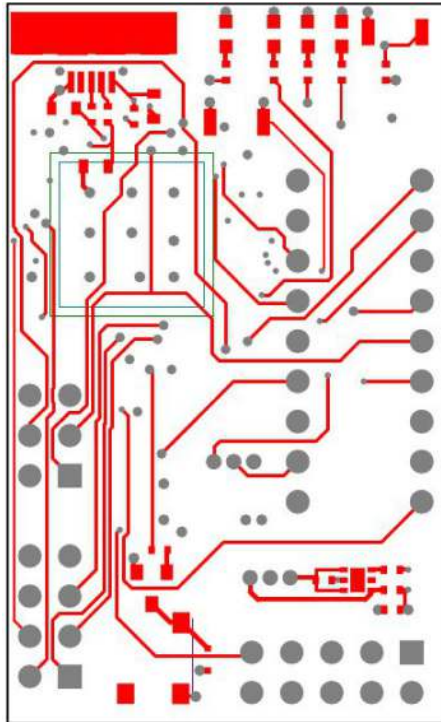

Figure 9-4. PC Interface Board; Middle Layer 1, Top View (as if PCB was Transparent)

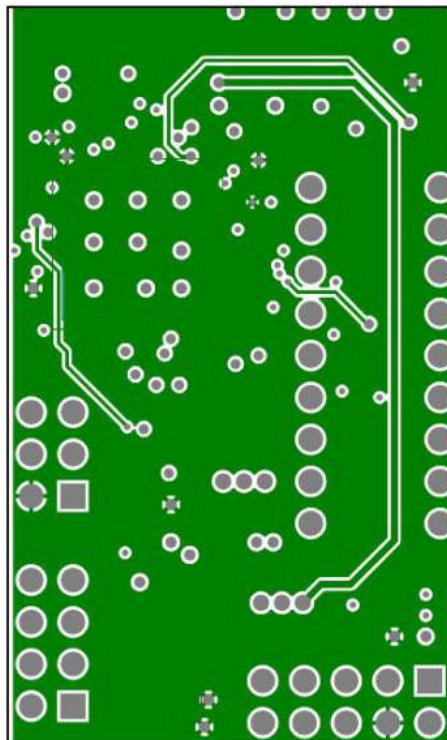



Figure 9-5. PC Interface Board; Middle Layer 2, Top View (as if PCB was Transparent)

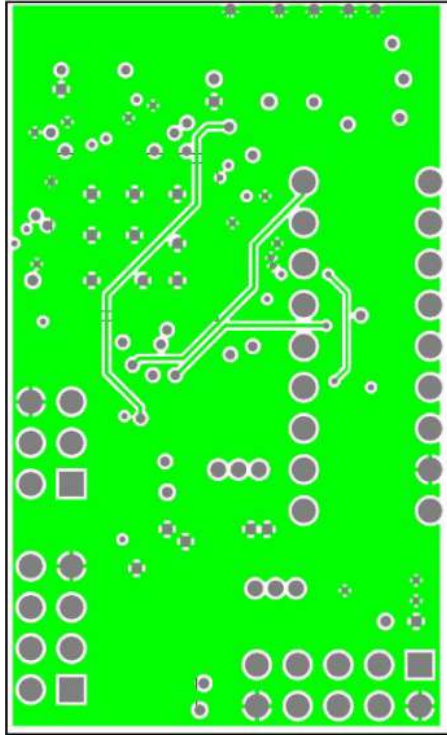

Figure 9-6. PC Interface Board; Bottom Side, Top View (as if PCB was Transparent)

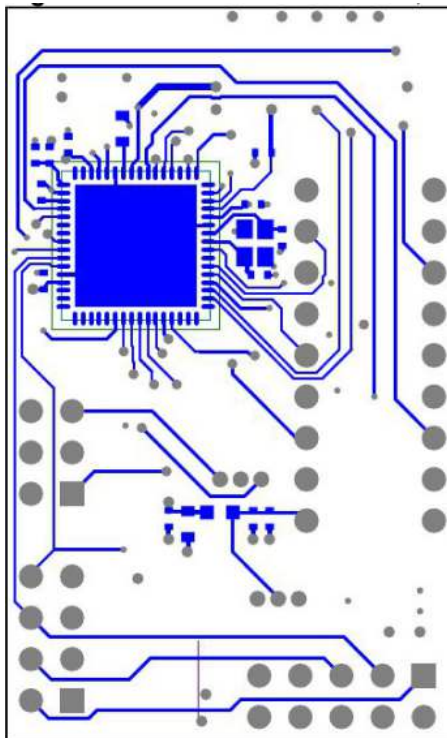

Figure 9-7. Atmel ATAB664251A Board Component Placement; Top Side, Top View

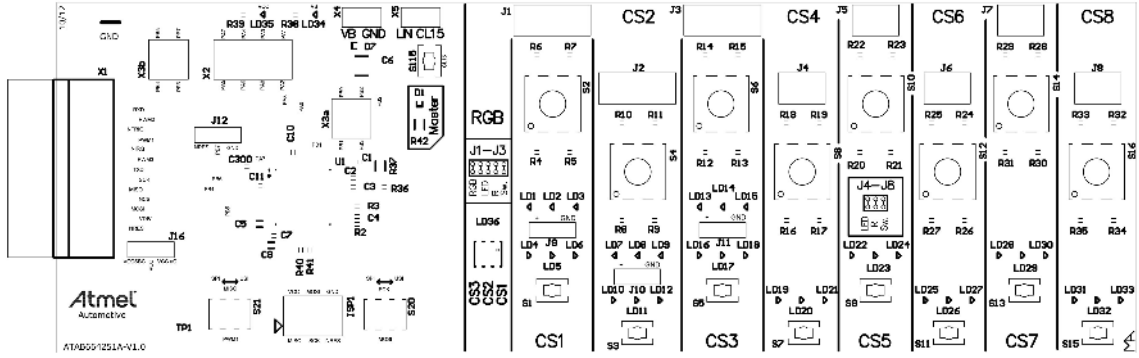

Figure 9-8. Atmel ATAB664251A Board; Top Side, Top View

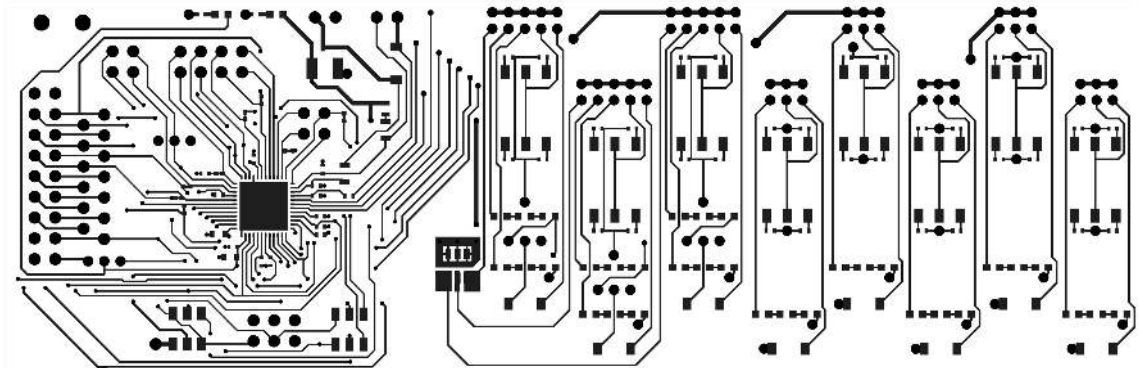
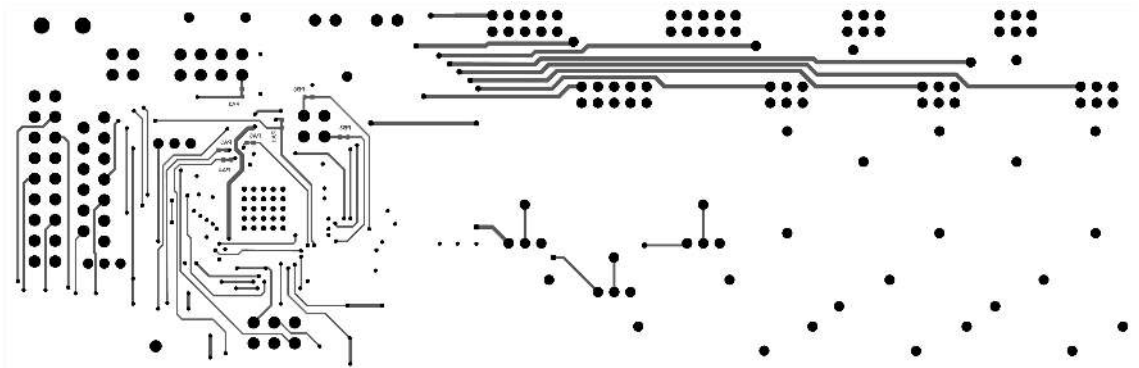

Figure 9-9. Atmel ATAB664251A Board; Bottom Side, Top View (as if PCB is Transparent)



## 10. Atmel ATA664251 Kit BOM

Table 10-1. PC Interface Board BOM

#	Designator	Quantity	Value	Class	Voltage	Tolerance	Description	Footprint	Manufacturer and Part Number
1	C1, C2, C4, C6, C11, C12, C16	4	100nF				CAP 0402	0402_C	
2	C3	1	1 $\mu$ F				CAP 0603	0603_C	
3	C5, C17	1	10 $\mu$ F				CAP 0603	0603_C	
5	C7	1	150pF				CAP 0402	0402_C	
6	C8	1	15nF				CAP 0402	0402_C	
7	C9, C10	2	22pF				CAP 0402	0402_C	
8	C13, C15	2	1 $\mu$ F				CAP 0402	0402_C	
9	C14	1	10nF				CAP 0402	0402_C	
11	D3	1					BAS516	SOD523_D	RS No: 508-282; Mfg P/N: BAS516
12	ISP1	1					Header, 3-Pin, Dual Row	HDR2X3_CEN 2.54mm	Samtec - TSW-105-24-S-D
13	J1, J2	2					Header, 3-Pin	Jumper 1x3 1.27mm	Samtec - MTMS-103.51-S-S-130
14	JTAG1	1					HDR 5X2 100MIL	HDR2X5_JTAG 2.54mm	Samtec
15	L1	1					IND 0603 EMI	0603_L	Mouser No: 875-MI0603J601R-10
16	L2	1	10 $\mu$ H				Inductor	0603_L	Würth: 744 796 8
17	LD1	1					Typical BLUE GaAs LED	0603_LED_BL	RS No: 700-8026
18	LD2	1					Typical YELLOW GaAs LED	0603_LED_GE	
19	LD3	1					Typical RED GaAs LED	0603_LED_rt	RS No: 466-3728P
20	LD4	1					Typical GREEN GaAs LED	0603_LED_gn	RS No: 466-3706P
21	Q1	1	16MHz				Crystal Unit SMD 2.5x2.0mm	CX2520	Kyocera - CX2520SB
22	R3, R4	2	22R				RES 0402 1k 5% 0.1W	0402_R	
23	R6	1	1k				RES 0402 1k 5% 0.1W	0402_R	
24	R7, R8, R9	3	825R				RES 0402 1k 5% 0.1W	0402_R	
25	R10	1	180R				RES 0402 1k 5% 0.1W	0402_R	
26	R15, R16	2	47k				RES 0402 0 $\Omega$ 5% 0.1W	0402_R	
27	R20, R21, R22	3	nc					0603_R	
28	S1, S2	2					Tact Switch - Vertical SMD	B3U-1000P	RS No: 682-1421

**Table 10-1. PC Interface Board BOM (Continued)**

#	Designator	Quantity	Value	Class	Voltage	Tolerance	Description	Footprint	Manufacturer and Part Number
29	Sp1	1					Buzzer, e.g., BST-5523SA	Buzzer_BST	Mouser No: 665-SMT0540SR
30	T1	1					High-Voltage NPN Transistor	SOT23-3	RS No: 545-0438P; Mfg P/N: MMBTA42LT1G
31	TFT1	1					Header, 4-Pin, Dual Row	HDR2X4_CEN	Samtec
32	U1	1					8-bit Microcontroller with 64/128Kbytes of ISP Flash and USB Controller	QFN64_5x5	Atmel - AT90USB1287
33	U2	1					VREG, 3.3V, 500A	MLF 6-Pin	DigiKey No: 576-2768-1-ND; MIC5219
34	X1	1					Mini USB Connector	USB-micro	Samtec - UUSB_B_S_S_SM_TR
35	X2	1					Header, 9-Pin, Dual Row	BCS-109-X-D-HE	Samtec - BCS-109-X-D-HE

**Table 10-2. Atmel ATAB664251A Board BOM**

#	Designator	Quantity	Value	Class	Voltage	Tolerance	Description	Footprint	Manufacturer and Part Number
1	U1	1	-				ATA664251	QFN32 5x5mm	Atmel ATA664251
2	C3	4	47nF				Surface-Mount Ceramic Multilayer Capacitor	RC-0402	
3	C7, C10, C11, C300	4	100nF				Surface-Mount Ceramic Multilayer Capacitor	RC-0402	
4	C5	1	100nF		50V		Surface-Mount Ceramic Multilayer Capacitor	RC-0603	
5	C6	1	10µF	X7R	50V	10%	Surface-Mount Ceramic Multilayer Capacitor	R3225	Mouser No: 81-GRM32ER71H106KA2L
6	C8	1	2.2µF	COG		5%	Surface-Mount Ceramic Multilayer Capacitor	RC-0603	
7	C2, C4	2	10nF	COG	50V (C2 only)	5%	Surface-Mount Ceramic Multilayer Capacitor	RC-0402	

**Table 10-2. Atmel ATAB664251A Board BOM (Continued)**

#	Designator	Quantity	Value	Class	Voltage	Tolerance	Description	Footprint	Manufacturer and Part Number
8	C1	1	220pF	COG	50V	5%	Surface-Mount Ceramic Multilayer Capacitor	RC-0402	
9	D1, D7	2					Diode	RC-1608	BAV302
10	J12	1					Jumper 1x3 2mm	J12	
11	J16	1	-				Jumper 1x3 2mm		Samtec
12	J9, J10, J11	3	-				Jumper 1x3 2mm		Samtec - MTMM-103-04-T-S-140
13	J1, J2, J3	3					Jumper 2x5 2mm		Samtec
14	J4, J5, J6, J7, J8	5					Jumper 2x3 2mm		Samtec - MTMM-103-04-T-D-140
15	X1						Header 2x9 2.54mm		Samtec - TSW-109-08-L-D-RA
16	X2						Header 2x4 2.54mm		
17	LD34	1					LED Blue	RC-0603	RS No: 700-8026
18	LD1, LD2, LD3, LD7, LD8, LD9, LD13, LD14, LD15,	9					LED Red	RC-0603	RS No: 466-3728P
19	LD4, LD5, LD6, LD10, LD11, LD12, LD16, LD17, LD18, LD19, LD20, LD21, LD22, LD23, LD24, LD25, LD26, LD27, LD28, LD29, LD30, LD31, LD32, LD33, LD35	25					LED Green	RC-0603	RS No: 466-3706P
20	LD36	1					RGB-LED	P-LCC-6	RS No: 708-0747P
21	GND	1					Messbuegel		
22	VB, GND, CL15, LIN	2					MessPin 1x2 2.54mm		
23	R3	1	12k				Chip Resistor Surface Mount	RC-0402	
24	R39	1	430R				Chip Resistor Surface Mount	RC-0402	
25	R40, R41	1	10k				Chip Resistor Surface Mount	RC-0402	
26	R42	1	1k				Chip Resistor Surface Mount	R2012	
27	R36, R42	2	47k				Chip Resistor Surface Mount	RC-0402	

**Table 10-2. Atmel ATAB664251A Board BOM (Continued)**

#	Designator	Quantity	Value	Class	Voltage	Tolerance	Description	Footprint	Manufacturer and Part Number
28	R2	1	51k				Chip Resistor Surface Mount	RC-0402	
29	R38	1	1k				Chip Resistor Surface Mount	RC-0402	
30	R37	1	56R				Chip Resistor Surface Mount	RC-0402	
31	R4, R8, R12, R16, R20, R27, R31, R35	8	820R				Chip Resistor Surface Mount	RC-0402	
32	R5, R9, R13, R17, R21, R26, R30, R34	8	200R				Chip Resistor Surface Mount	RC-0402	
33	R6, R10, R14, R18, R22, R25, R29, R33	8	100R				Chip Resistor Surface Mount	RC-0402	
34	R7, R11, R15, R19, R23, R24, R28, R32	8	390R				Chip Resistor Surface Mount	RC-0402	
35	S1, S3, S5, S7, S9, S11, S13, S15, S115	9					Tact Switch - Vertical SMD	TL1015	Mouser No: 612-TL1015AF
36	S2, S4, S6, S8, S10, S12, S14, S16	8					Rotary Switch	SMR_SW	RS No:702-3381P
37	S20, S21	2					SMD DIP Switch		
38	X3a, X3b	2					Header 2x2 2.54mm		
39	ISP1	1					Header 2x3 2.54mm		



**Atmel Corporation**  
1600 Technology Drive  
San Jose, CA 95110  
USA  
**Tel:** (+1) (408) 441-0311  
**Fax:** (+1) (408) 487-2600  
[www.atmel.com](http://www.atmel.com)

**Atmel Asia Limited**  
Unit 01-5 & 16, 19F  
BEA Tower, Millennium City 5  
418 Kwun Tong Roa  
Kwun Tong, Kowloon  
HONG KONG  
**Tel:** (+852) 2245-6100  
**Fax:** (+852) 2722-1369

**Atmel Munich GmbH**  
Business Campus  
Parkring 4  
D-85748 Garching b. Munich  
GERMANY  
**Tel:** (+49) 89-31970-0  
**Fax:** (+49) 89-3194621

**Atmel Japan G.K.**  
16F Shin-Osaki Kangyo Building  
1-6-4 Osaki  
Shinagawa-ku, Tokyo 141-0032  
JAPAN  
**Tel:** (+81) (3) 6417-0300  
**Fax:** (+81) (3) 6417-0370

© 2013 Atmel Corporation. All rights reserved. / Rev.: 9300C-AUTO-03/13

Atmel®, Atmel logo and combinations thereof, Enabling Unlimited Possibilities®, AVR®, and others are registered trademarks or trademarks of Atmel Corporation or its subsidiaries. Other terms and product names may be trademarks of others.

Disclaimer: The information in this document is provided in connection with Atmel products. No license, express or implied, by estoppel or otherwise, to any intellectual property right is granted by this document or in connection with the sale of Atmel products. EXCEPT AS SET FORTH IN THE ATMEL TERMS AND CONDITIONS OF SALES LOCATED ON THE ATMEL WEBSITE, ATMEL ASSUMES NO LIABILITY WHATSOEVER AND DISCLAIMS ANY EXPRESS, IMPLIED OR STATUTORY WARRANTY RELATING TO ITS PRODUCTS INCLUDING, BUT NOT LIMITED TO, THE IMPLIED WARRANTY OF MERCHANTABILITY, FITNESS FOR A PARTICULAR PURPOSE, OR NON-INFRINGEMENT. IN NO EVENT SHALL ATMEL BE LIABLE FOR ANY DIRECT, INDIRECT, CONSEQUENTIAL, PUNITIVE, SPECIAL OR INCIDENTAL DAMAGES (INCLUDING, WITHOUT LIMITATION, DAMAGES FOR LOSS AND PROFITS, BUSINESS INTERRUPTION, OR LOSS OF INFORMATION) ARISING OUT OF THE USE OR INABILITY TO USE THIS DOCUMENT, EVEN IF ATMEL HAS BEEN ADVISED OF THE POSSIBILITY OF SUCH DAMAGES. Atmel makes no representations or warranties with respect to the accuracy or completeness of the contents of this document and reserves the right to make changes to specifications and products descriptions at any time without notice. Atmel does not make any commitment to update the information contained herein. Unless specifically provided otherwise, Atmel products are not suitable for, and shall not be used in, automotive applications. Atmel products are not intended, authorized, or warranted for use as components in applications intended to support or sustain life.