

# HiPerFAST™ IGBT

## ISOPLUS247™

### B2-Class High Speed IGBTs

(Electrically Isolated Back Surface)

IXGR 60N60B2  
IXGR 60N60B2D1

$V_{CES}$  = 600 V  
 $I_{C25}$  = 75 A  
 $V_{CE(sat)}$  = 2.0 V  
 $t_{fi(typ)}$  = 100 ns

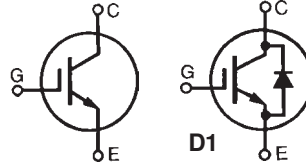

| Symbol                        | Test Conditions   | Maximum Ratings |                  |
|-------------------------------|---|-----------------|------------------|
| $V_{CES}$                     | $T_J = 25^\circ\text{C}$ to $150^\circ\text{C}$   | 600             | V                |
| $V_{CGR}$                     | $T_J = 25^\circ\text{C}$ to $150^\circ\text{C}$ ; $R_{GE} = 1\text{ M}\Omega$   | 600             | V                |
| $V_{GES}$                     | Continuous  | $\pm 20$        | V                |
| $V_{GEM}$                     | Transient   | $\pm 30$        | V                |
| $I_{C25}$                     | $T_C = 25^\circ\text{C}$ (limited by leads)   | 75              | A                |
| $I_{C110}$                    | $T_C = 110^\circ\text{C}$   | 47              | A                |
| $I_{CM}$                      | $T_C = 25^\circ\text{C}$ , 1 ms   | 300             | A                |
| <b>SSOA</b><br><b>(RBSOA)</b> | $V_{GE} = 15\text{ V}$ , $T_{VJ} = 125^\circ\text{C}$ , $R_G = 10\ \Omega$<br>Clamped inductive load @ $V_{CE} \leq 600\text{ V}$ | $I_{CM} = 150$  | A                |
| $P_C$                         | $T_C = 25^\circ\text{C}$  | 250             | W                |
| $T_J$                         |   | -55 ... +150    | $^\circ\text{C}$ |
| $T_{JM}$                      |   | 150             | $^\circ\text{C}$ |
| $T_{stg}$                     |   | -55 ... +150    | $^\circ\text{C}$ |
| $V_{ISOL}$                    | 50/60 Hz, RMS, $t = 1\text{ m}$   | 2500            | V                |
| <b>Weight</b>                 |   | 5               | g                |
|                               | Maximum lead temperature for soldering<br>1.6 mm (0.062 in.) from case for 10 s   | 300             | $^\circ\text{C}$ |

PLUS247(IXGR)  
E153432

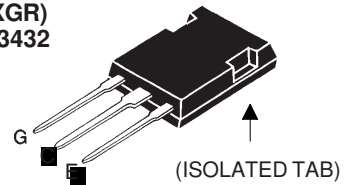

G = Gate      C = Collector  
E = Emitter

#### Features

- DCB Isolated mounting tab
- Meets TO-247AD package Outline
- High current handling capability
- Latest generation HDMOS™ process
- MOS Gate turn-on - drive simplicity

#### Applications

- Uninterruptible power supplies (UPS)
- Switched-mode and resonant-mode power supplies
- AC motor speed control
- DC servo and robot drives
- DC choppers

#### Advantages

- Easy assembly
- High power density
- Very fast switching speeds for high frequency applications

| Symbol        | Test Conditions  | Characteristic Values<br>( $T_J = 25^\circ\text{C}$ , unless otherwise specified) |      |                           |
|---------------|--|---|------|---------------------------|
|               |  | Min.  | Typ. | Max.                      |
| $V_{GE(th)}$  | $I_C = 250\ \mu\text{A}$ , $V_{CE} = V_{GE}$                             | 3.0   |      | 5.0 V                     |
| $I_{CES}$     | $V_{CE} = V_{CES}$<br>$V_{GE} = 0\text{ V}$<br>$T_J = 125^\circ\text{C}$ |   |      | 300 $\mu\text{A}$<br>5 mA |
| $I_{GES}$     | $V_{CE} = 0\text{ V}$ , $V_{GE} = \pm 20\text{ V}$                       |   |      | $\pm 100\text{ nA}$       |
| $V_{CE(sat)}$ | $I_C = 50\text{ A}$ , $V_{GE} = 15\text{ V}$<br>Note 1                   |   |      | 2.0 V                     |

| Symbol       | Test Conditions  | Characteristic Values<br>( $T_J = 25^\circ\text{C}$ , unless otherwise specified) |      |         |    |
|--------------|--|---|------|---------|----|
|              |  | Min.  | Typ. | Max.    |    |
| $g_{fs}$     | $I_C = 50\text{ A}; V_{CE} = 10\text{ V}$ ,<br>Note 1  | 40  | 58   | S       |    |
| $C_{ies}$    | $V_{CE} = 25\text{ V}, V_{GE} = 0\text{ V}, f = 1\text{ MHz}$  |   | 3900 | pF      |    |
| $C_{oes}$    |  |   | 340  | pF      |    |
| $C_{res}$    |  |   | 100  | pF      |    |
| $Q_g$        | $I_C = 50\text{ A}, V_{GE} = 15\text{ V}, V_{CE} = 0.5 V_{CES}$  |   | 170  | nC      |    |
| $Q_{ge}$     |  |   | 25   | nC      |    |
| $Q_{gc}$     |  |   | 57   | nC      |    |
| $t_{d(on)}$  | <b>Inductive load, <math>T_J = 25^\circ\text{C}</math></b><br>$I_C = 50\text{ A}, V_{GE} = 15\text{ V}$<br>$V_{CE} = 400\text{ V}, R_G = R_{off} = 3.3\ \Omega$  |   | 28   | ns      |    |
| $t_{ri}$     |  |   | 30   | ns      |    |
| $t_{d(off)}$ |  |   | 160  | 270     | ns |
| $t_{fi}$     |  |   | 100  | 170     | ns |
| $E_{off}$    |  |   | 1.0  | 2.5     | mJ |
| $t_{d(on)}$  | <b>Inductive load, <math>T_J = 125^\circ\text{C}</math></b><br>$I_C = 50\text{ A}, V_{GE} = 15\text{ V}$<br>$V_{CE} = 400\text{ V}, R_G = R_{off} = 2.0\ \Omega$ |   | 28   | ns      |    |
| $t_{ri}$     |  |   | 36   | ns      |    |
| $E_{on}$     |  |   | 1.5  | mJ      |    |
| $t_{d(off)}$ |  |   | 310  | ns      |    |
| $t_{fi}$     |  |   | 240  | ns      |    |
| $E_{off}$    |  | 2.8   | mJ   |         |    |
| $R_{thJC}$   |  |   | 0.15 | 0.5 K/W |    |
| $R_{thCK}$   |  |   |      | K/W     |    |

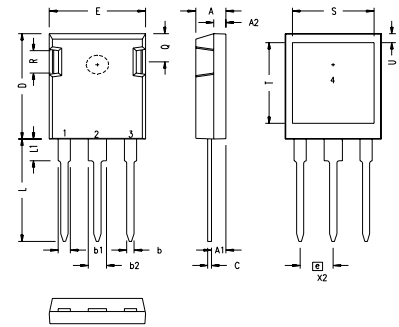
**ISOPLUS 247 Outline**

| SYM | INCHES   |      | MILLIMETERS |       |
|-----|----------|------|-------------|-------|
|     | MIN      | MAX  | MIN         | MAX   |
| A   | .190     | .205 | 4.83        | 5.21  |
| A1  | .090     | .100 | 2.29        | 2.54  |
| A2  | .075     | .085 | 1.91        | 2.16  |
| b   | .045     | .055 | 1.14        | 1.40  |
| b1  | .075     | .084 | 1.91        | 2.13  |
| b2  | .115     | .123 | 2.92        | 3.12  |
| C   | .024     | .031 | 0.61        | 0.80  |
| D   | .819     | .840 | 20.80       | 21.34 |
| E   | .620     | .635 | 15.75       | 16.13 |
| e   | .215 BSC |      | 5.45 BSC    |       |
| L   | .780     | .800 | 19.81       | 20.32 |
| L1  | .150     | .170 | 3.81        | 4.32  |
| Q   | .220     | .244 | 5.59        | 6.20  |
| R   | .170     | .190 | 4.32        | 4.83  |
| S   | .520     | .540 | 13.21       | 13.72 |
| T   | .620     | .640 | 15.75       | 16.26 |
| U   | .065     | .080 | 1.65        | 2.03  |

- 1 - GATE
- 2 - DRAIN (COLLECTOR)
- 3 - SOURCE (EMITTER)
- 4 - NO CONNECTION

NOTE: This drawing will meet all dimensions requirement of JEDEC outline TO-247AD except screw hole.

**Reverse Diode (FRED)**

| Symbol     | Test Conditions  | Characteristic Values<br>( $T_J = 25^\circ\text{C}$ , unless otherwise specified) |      |          |
|------------|--|---|------|----------|
|            |  | min.  | typ. | max.     |
| $V_F$      | $I_F = 60\text{ A}, V_{GE} = 0\text{ V}$ ,<br>Note 1   |   |      | 2.1 V    |
|            |  |   |      | 1.4 V    |
| $I_{RM}$   | $I_F = 60\text{ A}, V_{GE} = 0\text{ V}, -di_F/dt = 100\text{ A}/\mu\text{s}$<br>$T_J = 100^\circ\text{C}$<br>$V_R = 100\text{ V}$ |   |      | 8.3 A    |
| $t_{rr}$   | $I_F = 1\text{ A}; -di/dt = 200\text{ A}/\text{ms}; V_R = 30\text{ V}$   |   | 35   | ns       |
| $R_{thJC}$ |  |   |      | 0.85 K/W |

Note 1: Pulse test,  $t \leq 300\ \mu\text{s}$ , duty cycle  $\leq 2\%$

IXYS reserves the right to change limits, test conditions, and dimensions.

**Fig. 1. Output Characteristics**  
**@ 25 Deg. C**

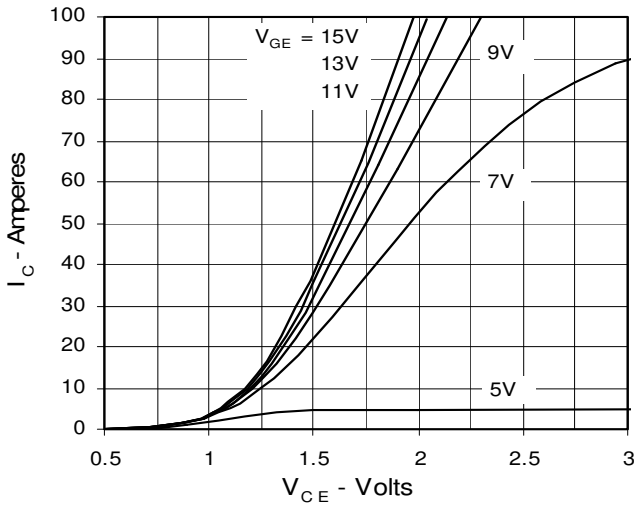

**Fig. 2. Extended Output Characteristics**  
**@ 25 deg. C**

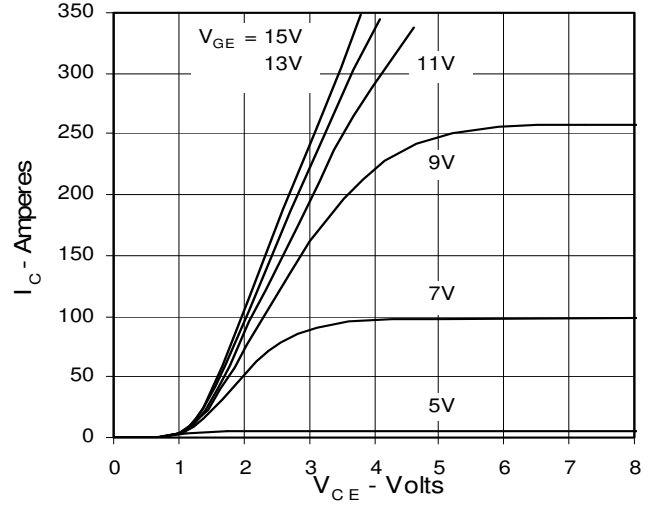

**Fig. 3. Output Characteristics**  
**@ 125 Deg. C**

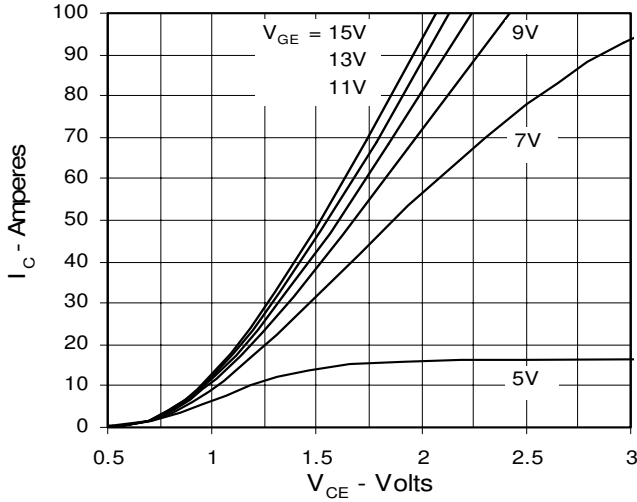

**Fig. 4. Dependence of  $V_{CE(sat)}$  on Temperature**

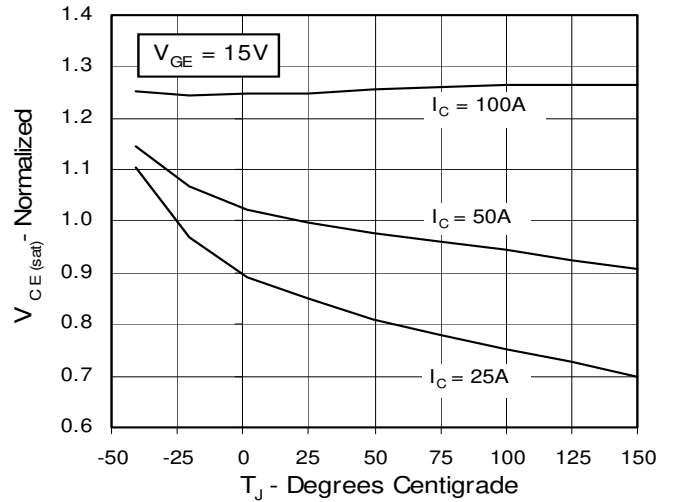

**Fig. 5. Collector-to-Emitter Voltage vs. Gate-to-Emitter voltage**

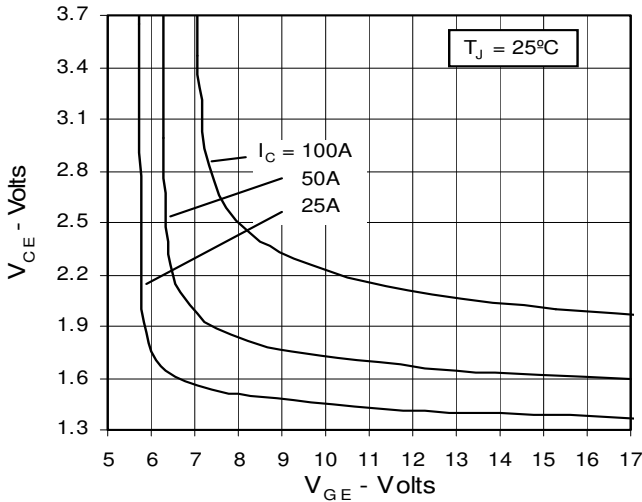

**Fig. 6. Input Admittance**

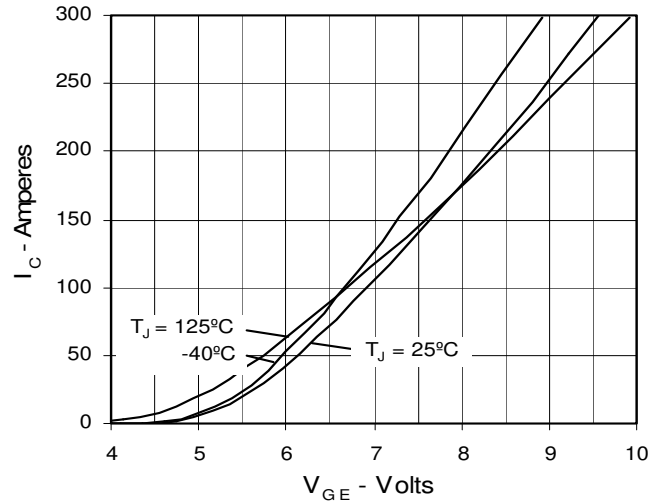

Fig. 7. Transconductance

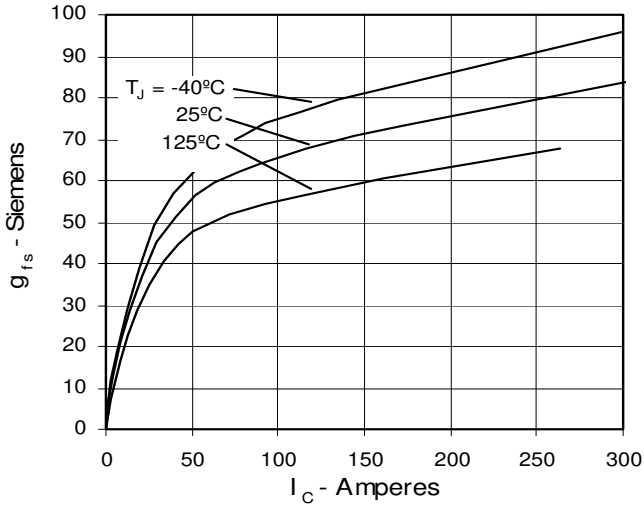

Fig. 8. Dependence of Turn-Off Energy on  $R_G$

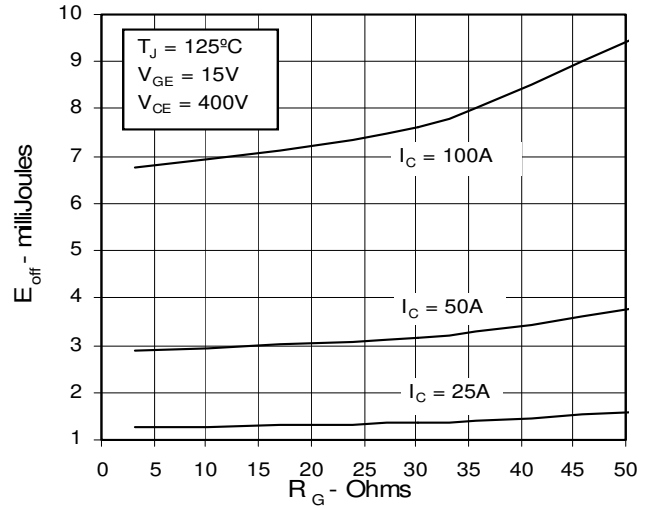

Fig. 9. Dependence of Turn-Off Energy on  $I_C$

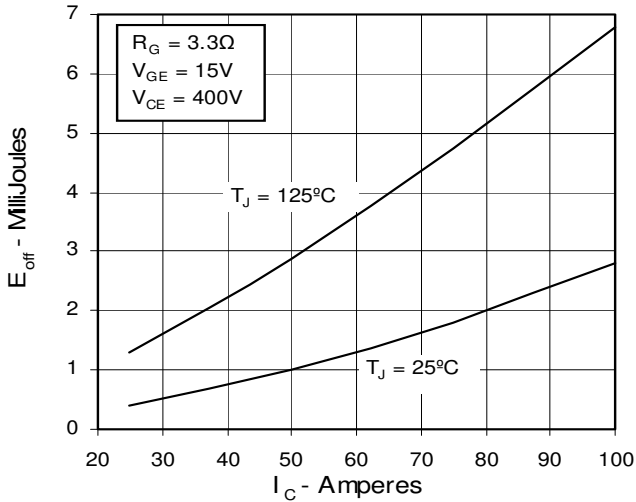

Fig. 10. Dependence of Turn-Off Energy on Temperature

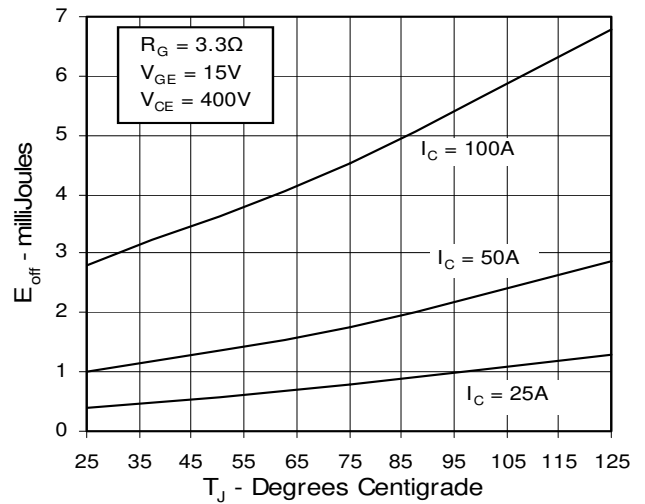

Fig. 11. Dependence of Turn-Off Switching Time on  $R_G$

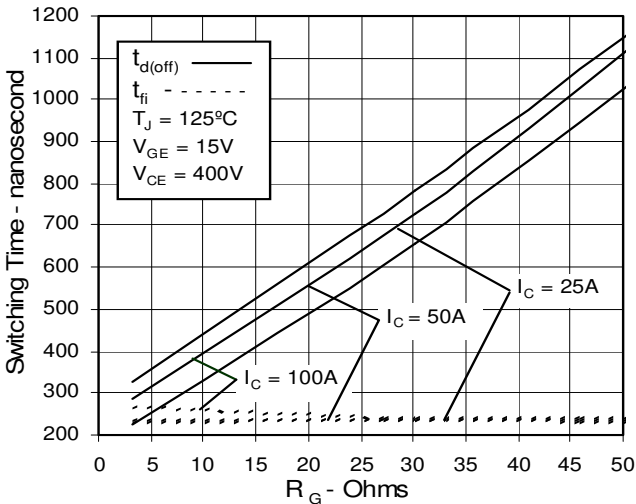
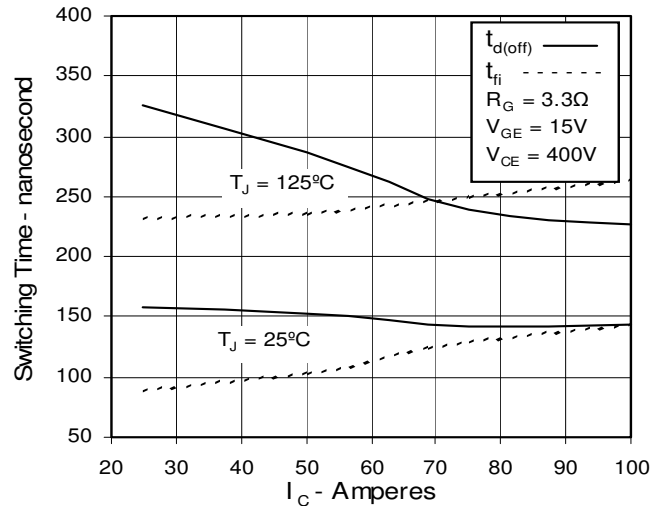
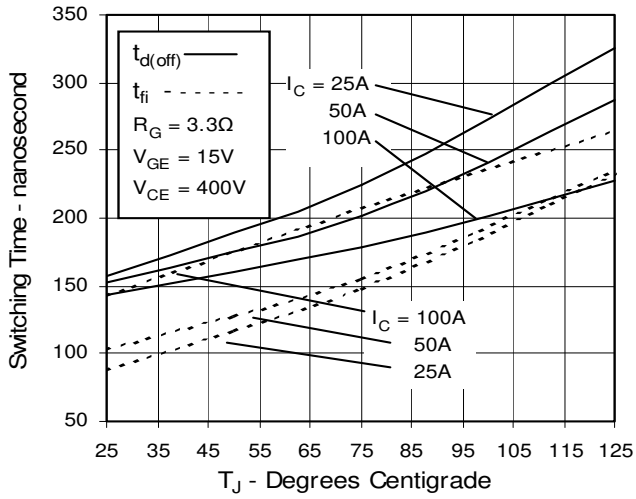

Fig. 12. Dependence of Turn-Off Switching Time on  $I_C$



**Fig. 13. Dependence of Turn-Off Switching Time on Temperature**



**Fig. 14. Gate Charge**

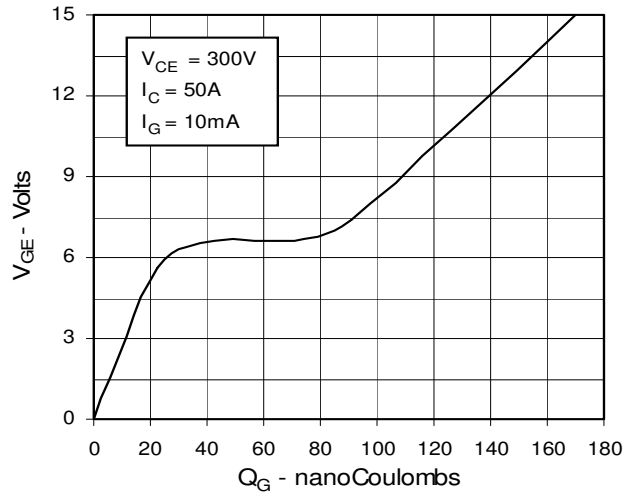

**Fig. 15. Capacitance**

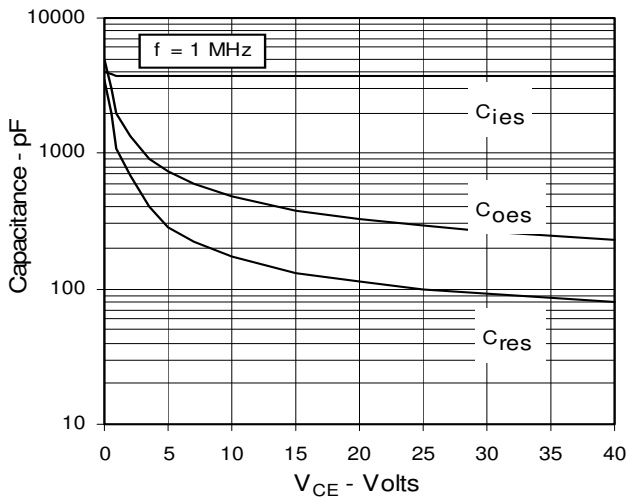

**Fig. 13. Maximum Transient Thermal Resistance**

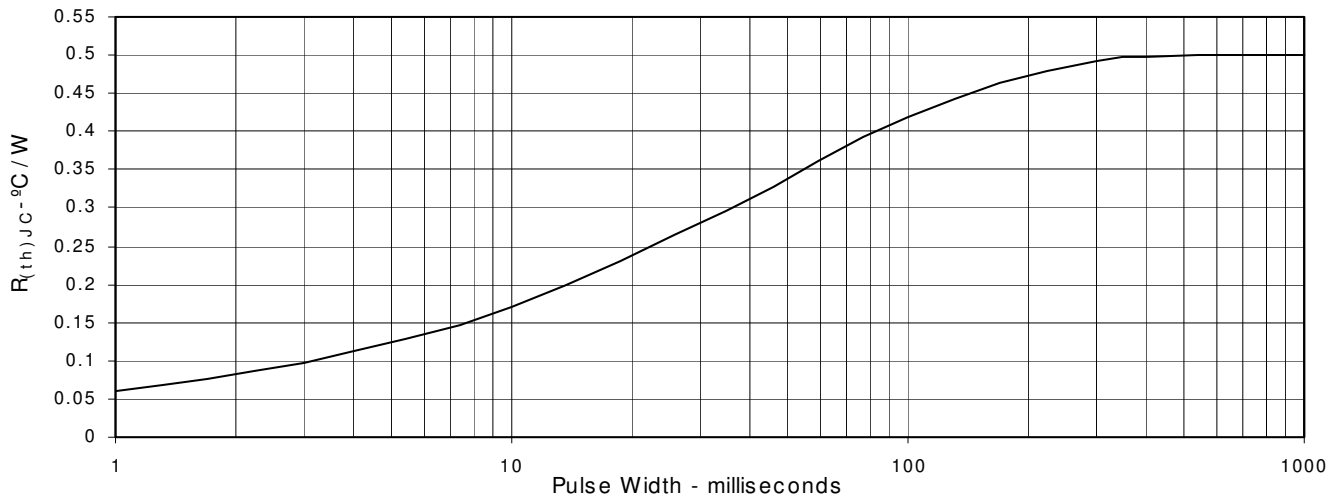

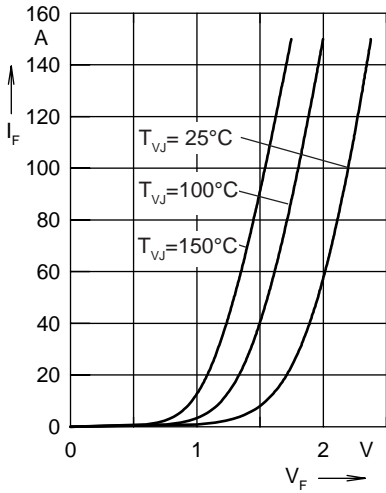

Fig. 17. Forward current  $I_F$  versus  $V_F$

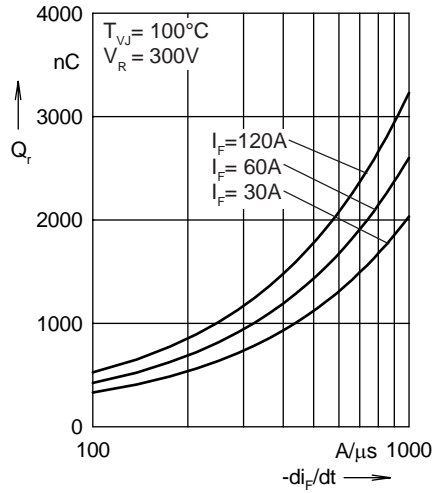

Fig. 18. Reverse recovery charge  $Q_r$  versus  $-di_F/dt$

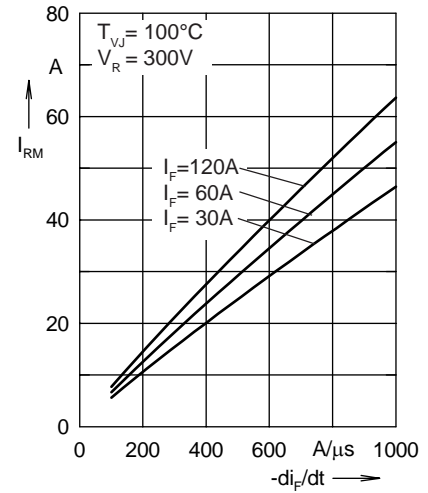

Fig. 19. Peak reverse current  $I_{RM}$  versus  $-di_F/dt$

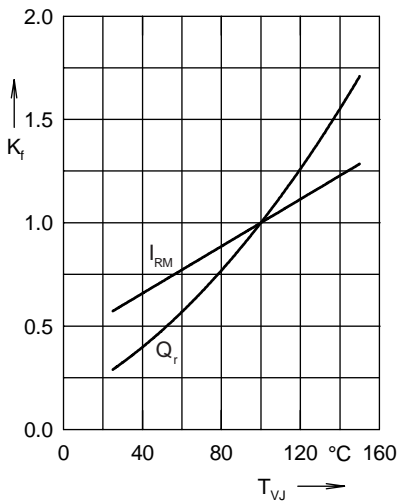

Fig. 20. Dynamic parameters  $Q_r$ ,  $I_{RM}$  versus  $T_{VJ}$

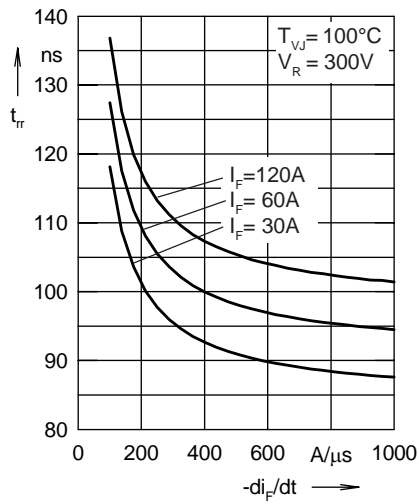

Fig. 21. Recovery time  $t_{tr}$  versus  $-di_F/dt$

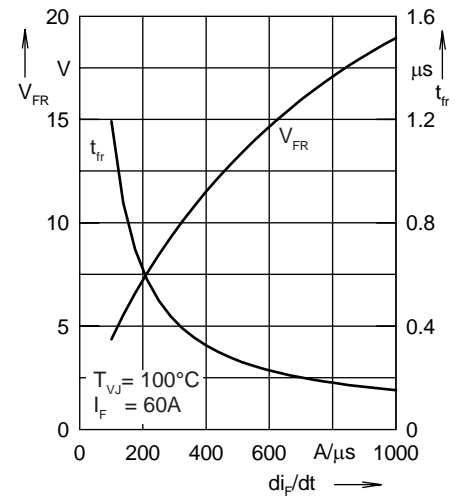

Fig. 22. Peak forward voltage  $V_{FR}$  and  $t_{tr}$  versus  $di_F/dt$

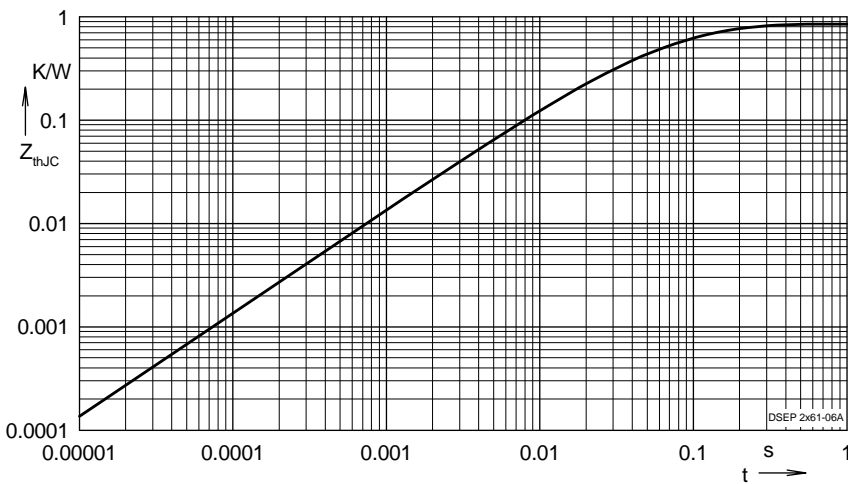

Fig. 23. Transient thermal resistance junction to case

Constants for  $Z_{thJC}$  calculation:

| i | $R_{thi}$ (K/W) | $t_i$ (s) |
|---|-----------------|-----------|
| 1 | 0.3073          | 0.0055    |
| 2 | 0.3533          | 0.0092    |
| 3 | 0.0887          | 0.0007    |
| 4 | 0.1008          | 0.0399    |