

90155-AS

SOLDERTAIL SPRING LOADED CONTACT

Visit us at WWW.PRECI-DIP.COM



preci-dip

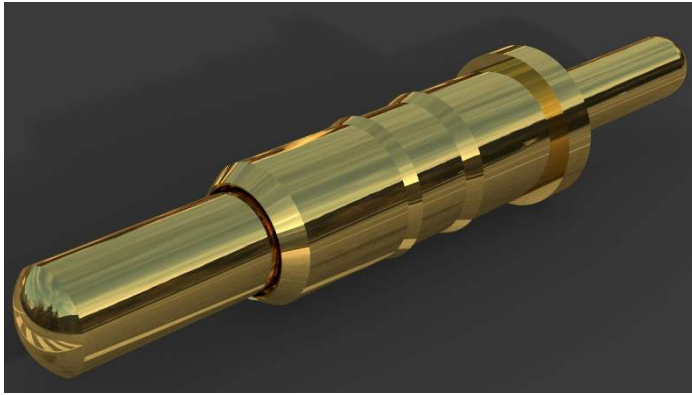

Engineered for Success

Assembly: Soldertail
Overall Length:
10mm (.394")
Above Board Height:
7mm (.276")
Stroke: 1.4mm (.055")

**ORDER AS:
90155-AS**

APPLICATION NOTES:

PRODUCT DESCRIPTION:

Preci-Dip Spring Loaded contact soldertail termination for wave or hand soldering. Every Preci-Dip spring contact is Swiss precision machined and assembled for highest quality, performance and long product life.

PRODUCT PACKAGING:

This product is sold in bulk but is also available but can be provided assembled in an insulator. Let us help you with your custom packaging request.

HOW TO USE THIS PRODUCT:

This product is ideal for PCB applications on 2.54mm (.100") grid. With solid one-piece body construction, These spring loaded contacts are typically used in docking stations, recharging stations, module stacking and pluggable SLC requirements.

CAN I CUSTOMIZE THIS PRODUCT?

Preci-Dip welcomes custom design requests. Please provide us your spring force and packaging requirements. Call today to discuss your application.

Temperature rise [°C]

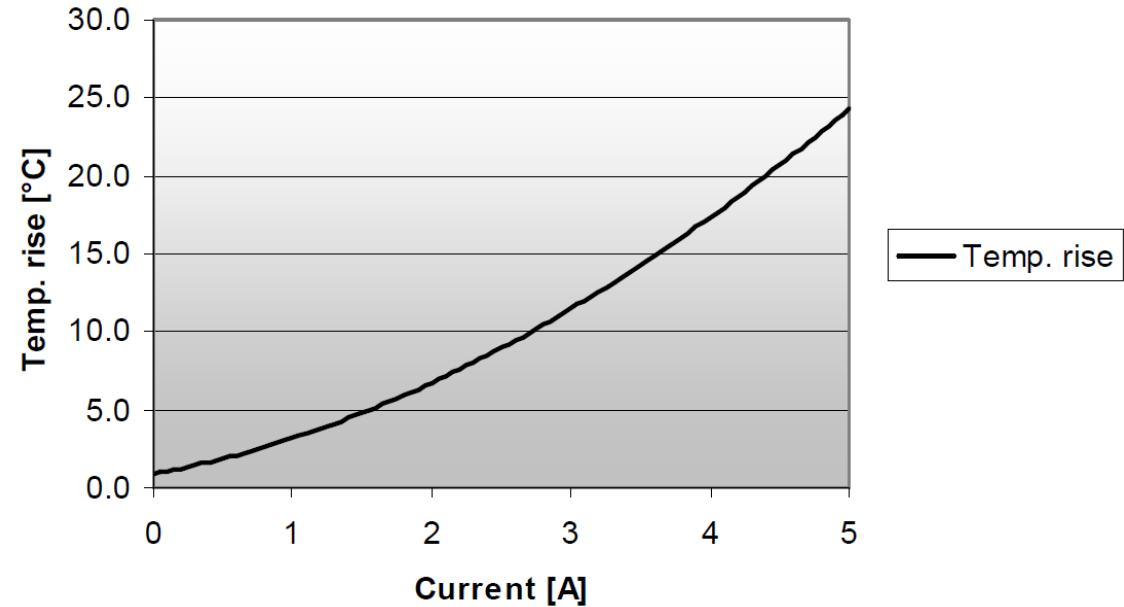

Current: 3A continuous @ 10 ° C rise

Soldertail

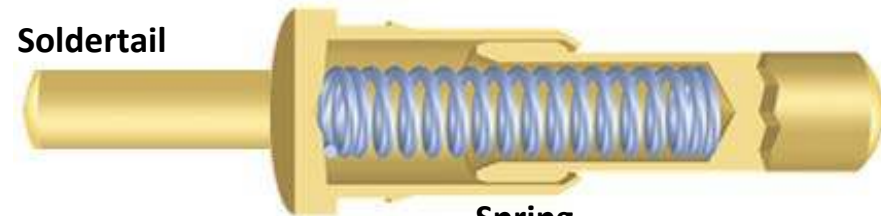

Piston

Spring

HOW IT WORKS:

Strong, secure and featuring one piece solid body construction, there are no capped components at the bottom of this spring contact. No seams for solder to wick inside the shell.



90155-AS

SOLDERTAIL SPRING LOADED CONTACT

Visit us at WWW.PRECI-DIP.COM



preci-dip

SPECIFICATIONS:

MATERIAL:

Piston: Brass Alloy, plated 0.5um (20μ") Gold
Barrel: Brass Alloy, plated 0.25um (10μ") Gold
Spring: Music Wire plated Gold Flash

ELECTRICAL:

Current: 3A continuous @ @ 10 ° C rise. 5A Peak.
Rated Voltage: 100Vrms 150Vdc
Contact Resistance: 20mΩ max..

ENVIRONMENTAL

Operating Temperature: -55 to 125° C
Passed Vibration Test Sinusoidal per IEC 512.6d / IEC 68-2-6
Passed Shock Test per IEC 512.6d / IEC 68-2-27
No electrical discontinuity greater than 1μs.

SPRING CONTACT FEATURES:

- * Swiss Experience
- * Swiss Quality
- * Swiss precision machined components
- * Seamless shell construction
- * Press-fit barb on barrel for packaging
- * Gold plating for corrosion resistance.
- * Smooth piston travel
- * High quality, smooth surface finish on tip of piston.
- * Strong and durable construction
- * RoHs

See 90155-AS in an insulator:

811-S1-NNN-10-016101

813-S1-NNN-10-016101

Note about S1 plating:

Barrel = 0.25um Gold

Piston= 0.50um Gold

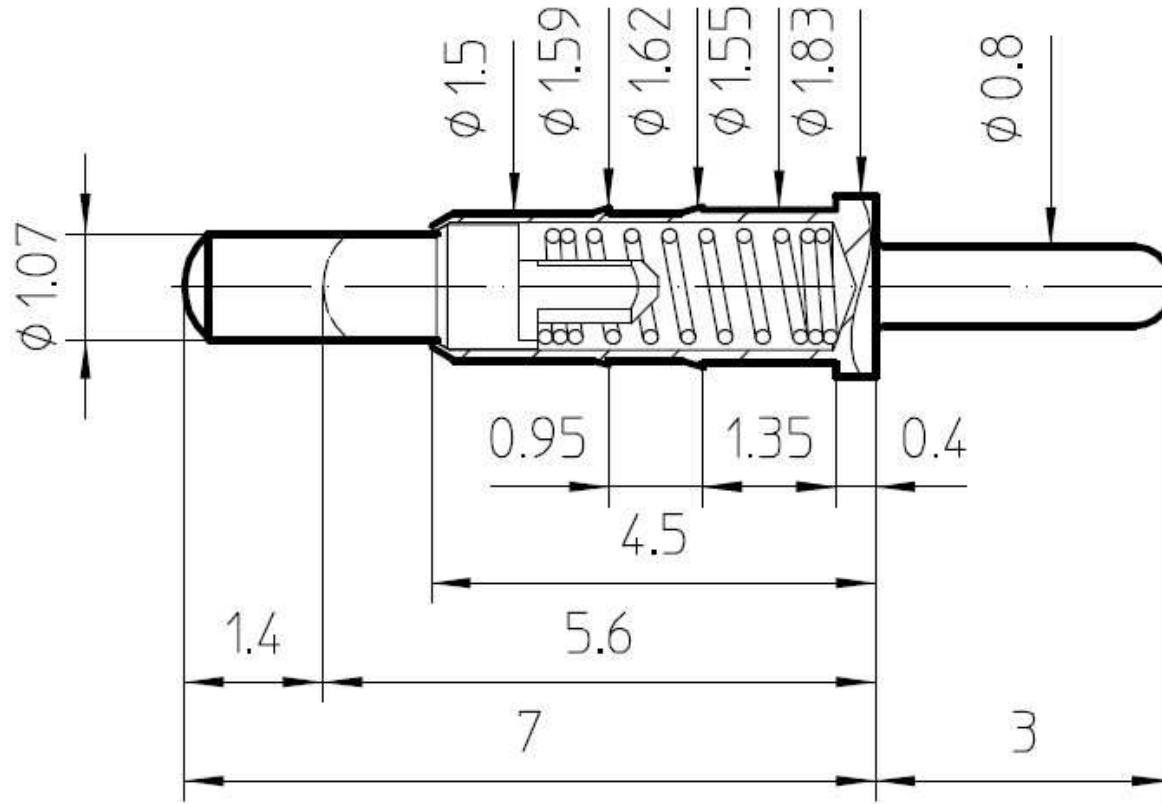

MECHANICAL

Durability: Minimum 40,000 cycles.
Stroke: 1.4mm (.055")
Working Travel: 7-5.65mm
(.276-.222")
Force: Initial .25N
Half-Stroke .85N

HOW TO CUSTOMIZE A SPRING CONTACT

Specify:

1. Stacking distance between boards
2. Desired piston stroke
3. Desired spring force
4. Desired current rating.
5. Termination style SMT, Solder tail, Wire
6. Desired Cycle life

