

TLE4699

Low Drop Out Linear Voltage Regulator
5 V Fixed Output Voltage

Data Sheet

Rev. 1.0, 2010-11-30

Automotive Power

Table of Contents

1	Overview	3
2	Block Diagram	4
3	Pin Configuration	5
3.1	Pin Assignment TLE4699GM (PG-DSO-14)	5
3.2	Pin Definitions and Functions TLE4699GM (PG-DSO-14)	5
3.3	Pin Assignment TLE4699E	7
3.4	Pin Definitions and Functions TLE4699E (PG-SSOP-14 EP)	7
4	General Product Characteristics	9
4.1	Absolute Maximum Ratings	9
4.2	Functional Range	10
4.3	Thermal Resistance	11
5	Voltage Regulator	12
5.1	Description Voltage Regulator	12
5.2	Electrical Characteristics Voltage Regulator	13
5.3	Typical Performance Characteristics Voltage Regulator	14
6	Current Consumption	16
6.1	Electrical Characteristics Current Consumption	16
6.2	Typical Performance Characteristics Current Consumption	17
7	Enable Function	18
7.1	Description Enable Function	18
7.2	Electrical Characteristics Enable Function	18
7.3	Typical Performance Characteristics Enable Input	19
8	Reset Function	20
8.1	Description Reset Function	20
8.2	Electrical Characteristics Reset Function	23
8.3	Typical Performance Characteristics Reset Function	24
9	Early Warning Function	25
9.1	Description Early Warning Function	25
9.2	Electrical Characteristics Early Warning Function	27
9.3	Typical Performance Characteristics Early Warning Function	27
10	Package Outlines	28
11	Revision History	30



1 Overview

Features

- Output Voltage $5\text{ V} \pm 2\%$
- Current Capability 200 mA
- Ultra Low Current Consumption
- Very Low Drop Out Voltage
- Enable Function: Below $1\mu\text{A}$ Current Consumption in off mode
- Reset Circuit Sensing the Output Voltage with Programmable Switching Threshold and Delay Time
- Reset Output Active Low Down to $V_Q = 1\text{ V}$
- Integrated Early Warning Comparator
- Excellent Line Transient Robustness
- Maximum Input Voltage $-42\text{ V} \leq V_I \leq +45\text{ V}$
- Reverse Polarity Protection
- Short Circuit Protected
- Overtemperature Shutdown
- Automotive Temperature Range $-40\text{ }^\circ\text{C} \leq T_j \leq 150\text{ }^\circ\text{C}$
- Available in a small thermally enhanced PG-SSOP-14 EP package
- Green Product (RoHS Compliant)
- AEC Qualified



PG-DSO-14

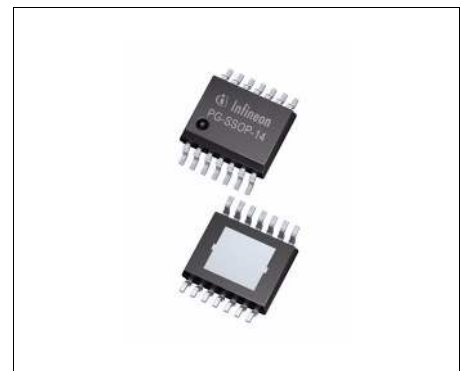

PG-SSOP-14 EP

Description

The TLE4699 is a monolithic integrated low drop out fixed output voltage regulator for loads up to 200 mA. An input voltage of up to 45 V is regulated to an output voltage of 5 V. The integrated reset as well as several protection circuits, combined with a wide operating temperature range offered by the TLE4699 make it suitable for supplying microprocessor systems in automotive environments.

The early warning function supervises the voltage at pin SI. Modifying the reset threshold is possible by an optional resistor divider.

The TLE4699 is available in a PG-DSO-14 package which makes it pin-compatible to the TLE4299 as well as in a small thermally enhanced PG-SSOP-14 EP exposed pad package.

Type	Package	Marking
TLE4699GM	PG-DSO-14	TLE4699
TLE4699E	PG-SSOP-14 EP	TLE4699

2 Block Diagram

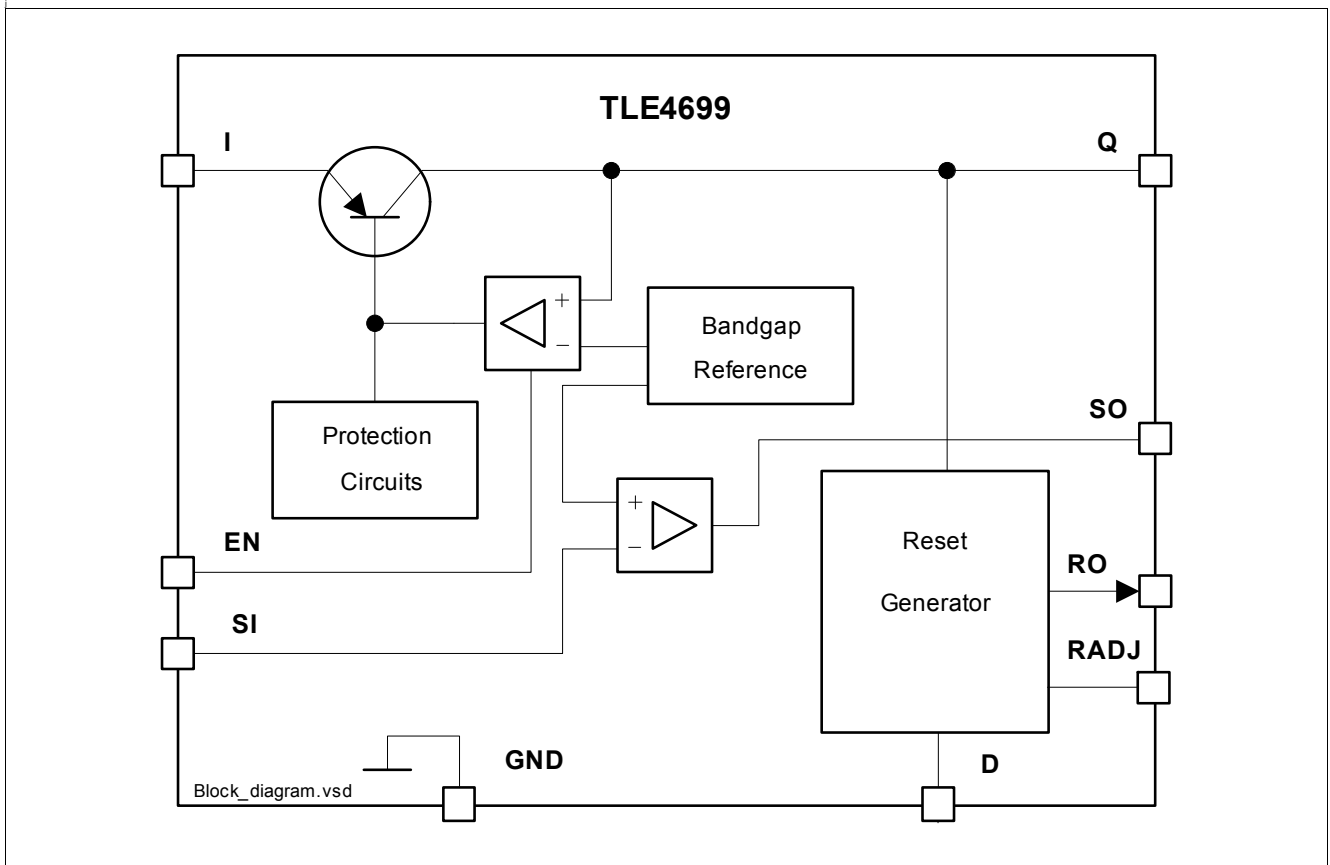

Figure 1 Block Diagram TLE4699

3 Pin Configuration

3.1 Pin Assignment TLE4699GM (PG-DSO-14)

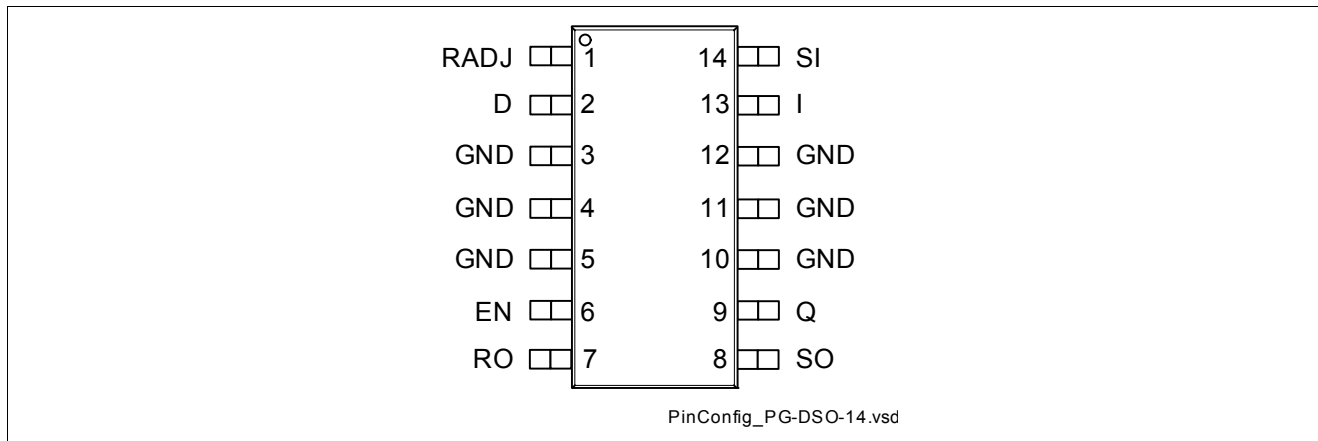

Figure 2 Pin Configuration PG-DSO-14 Package (top view)

3.2 Pin Definitions and Functions TLE4699GM (PG-DSO-14)

Pin	Symbol	Function
1	RADJ	Reset Threshold Adjust Connect an external voltage divider to adjust reset threshold; Connect to GND for using internal threshold.
2	D	Reset Delay Connect a ceramic capacitor from D (Pin 2) to GND for reset delay time adjustment; Leave open, if the reset function is not needed.
3, 4, 5	GND	Ground Connect all pins to heat sink area.
6	EN	Enable High signal enables the regulator; Low signal disables the regulator; Connect to I if the enable function is not needed
7	RO	Reset Output Open collector output with an internal pull-up resistor to the output Q; An additional external pull-up resistor to the output Q is optional; Leave open if the reset function is not needed.
8	SO	Sense Output Open collector output with an internal pull-up resistor to the output Q; An additional external pull-up resistor to the output Q is optional; Leave open if the sense function is not needed.
9	Q	5 V Regulator Output Connect a capacitor between Q (Pin 9) and GND close to the IC pins, respecting the values given for its capacitance C_Q and ESR in the table Chapter 4.2 Functional Range .
10, 11, 12	GND	Ground Connect all pins to heat sink area.

Pin Configuration

Pin	Symbol	Function
13	I	Regulator Input and IC Supply for compensating line influences, a capacitor to GND close to the IC pin is recommended.
14	SI	Sense Input Connect the voltage rail to be monitored; Connect to Q if the sense comparator is not needed.

3.3 Pin Assignment TLE4699E

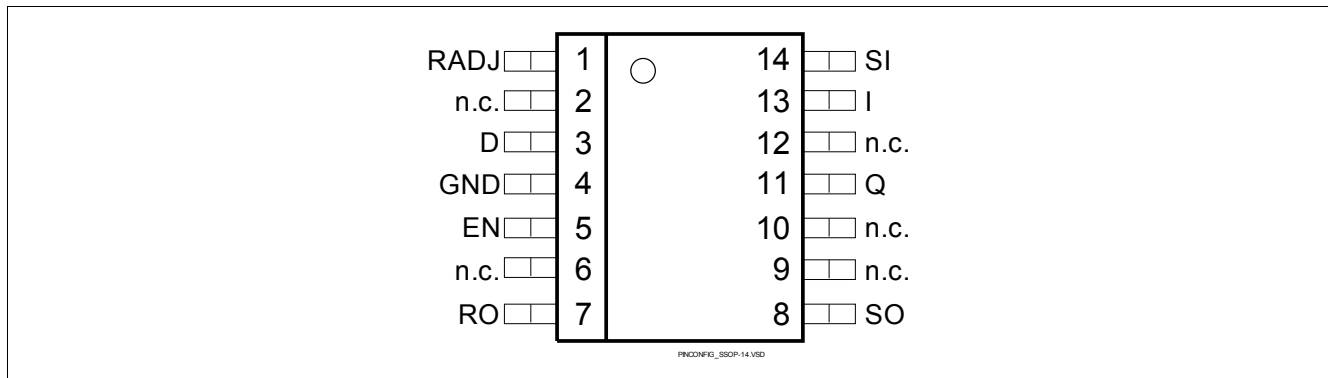

Figure 3 Pin Configuration PG-SSOP-14 EP Package (top view)

3.4 Pin Definitions and Functions TLE4699E (PG-SSOP-14 EP)

Pin	Symbol	Function
1	RADJ	Reset Threshold Adjust Connect an external voltage divider to adjust reset threshold; Connect to GND for using internal threshold.
3	D	Reset Delay Connect a ceramic capacitor from D (Pin 3) to GND for reset delay time adjustment; Leave open, if the reset function is not needed.
4	GND	Ground Connect to heat sink area.
5	EN	Enable High signal enables the regulator; Low signal disables the regulator; Connect to I if the enable function is not needed
7	RO	Reset Output Open collector output with an internal pull-up resistor to the output Q; An additional external pull-up resistor to the output Q is optional; Leave open if the reset function is not needed.
8	SO	Sense Output Open collector output with an internal pull-up resistor to the output Q; An additional external pull-up resistor to the output Q is optional; Leave open if the sense function is not needed.
11	Q	5 V Regulator Output Connect a capacitor between Q (Pin 11) and GND close to the IC pins, respecting the values given for its capacitance C_Q and ESR in the table Chapter 4.2 Functional Range .
13	I	Regulator Input and IC Supply For compensating line influences, a capacitor to GND close to the IC pin is recommended.
14	SI	Sense Input Connect the voltage rail to be monitored; Connect to Q if the sense comparator is not needed.

Pin Configuration

Pin	Symbol	Function
2, 6, 9, 10, 12	n.c.	Not connected Internally not connected; Connection to PCB GND recommended.
PAD		Exposed Pad Attach the exposed pad on package bottom to the heatsink area on circuit board; Connect to GND

4 General Product Characteristics

4.1 Absolute Maximum Ratings

Absolute Maximum Ratings ¹⁾

$T_j = -40\text{ °C}$ to $+150\text{ °C}$; all voltages with respect to ground, positive current flowing into pin (unless otherwise specified)

Pos.	Parameter	Symbol	Limit Values		Unit	Conditions
			Min.	Max.		
Voltage Rating						
4.1.1	Regulator Input and IC Supply I	V_I	-42	45	V	–
4.1.2	Enable Input EN	V_{EN}	-42	45	V	–
4.1.3	Sense Input SI	V_{SI}	-42	45	V	–
4.1.4	Regulator Output Q	V_Q	-1	7	V	–
4.1.5	Sense Output SO	V_{WI}	-0.3	7	V	–
4.1.6	Reset Output RO	V_{RO}	-0.3	7	V	–
4.1.7	Reset Delay D	V_D	-0.3	7	V	–
4.1.8	Reset Switching Threshold Adjust RADJ	V_{RADJ}	-0.3	7	V	–
Temperatures						
4.1.9	Junction Temperature	T_j	-40	150	°C	–
4.1.10	Storage Temperature	T_{stg}	-55	150	°C	–
ESD Susceptibility						
4.1.11	ESD Resistivity	V_{ESD}	-4	4	kV	HBM ²⁾
4.1.12	ESD Resistivity	V_{ESD}	-1500	1500	V	CDM ³⁾

1) Not subject to production test, specified by design.

2) ESD susceptibility, Human Body Model “HBM” according to AEC-Q100-002-JESD 22-A114.

3) ESD susceptibility, Charged Device Model “CDM” according to ESDA STM5.3.1.

Note: Stresses above the ones listed here may cause permanent damage to the device. Exposure to absolute maximum rating conditions for extended periods may affect device reliability.

Note: Integrated protection functions are designed to prevent IC destruction under fault conditions described in the data sheet. Fault conditions are considered as “outside” normal operating range. Protection functions are not designed for continuous repetitive operation.

4.2 Functional Range

Pos.	Parameter	Symbol	Limit Values		Unit	Conditions
			Min.	Max.		
4.2.1	Input Voltage Range for Normal Operation	$V_{I(nor)}$	$V_Q + V_{dr}$	45	V	¹⁾
4.2.2	Extended Input Voltage Range	$V_{I(ext)}$	3.3	45	V	²⁾
4.2.3	Input Voltage Transient Immunity	dV_I/dt	-10	20	V/ μ s	$dV_I \leq 10$ V; $V_I > 9$ V; No trigger of RO. ³⁾
4.2.4	Junction Temperature	T_j	-40	150	°C	–
4.2.5	Output Capacitor	C_Q	10	–	μ F	– ⁴⁾
4.2.6	Requirements	ESR_{CQ}	–	3	Ω	– ⁵⁾

1) For specification of the input voltage V_Q and the drop out voltage V_{dr} see [Chapter 5 Voltage Regulator](#).

2) The output voltage V_Q will follow the input voltage, but is outside the specified range. For details see [Chapter 5 Voltage Regulator](#).

3) Transient measured directly at the input pin. Not subject to production test, specified by design.

4) Not subject of production test, specified by design.

The minimum output capacitance requirement is applicable for a worst case capacitance tolerance of 30%

5) Relevant ESR value at $f = 10$ kHz

Note: Within the functional range the IC operates as described in the circuit description. The electrical characteristics are specified within the conditions given in the related electrical characteristics table.

4.3 Thermal Resistance

Pos.	Parameter	Symbol	Limit Values			Unit	Conditions
			Min.	Typ.	Max.		
TLE4699GM Package PG-DSO-14							
4.3.1	Junction to Soldering Point ¹⁾	R_{thJSP}	–	27	–	K/W	Pins 3-5 and 10-12 fixed to T_A
4.3.2	Junction to Ambient	R_{thJA}	–	112	–	K/W	Footprint only ²⁾
4.3.3			–	73	–	K/W	300 mm ² PCB heat sink area ²⁾
4.3.4			–	65	–	K/W	600 mm ² PCB heat sink area ²⁾
4.3.5			–	63	–	K/W	2s2p PCB ³⁾
TLE4699E Package PG-SSOP-14 EP							
4.3.6	Junction to Soldering Point ¹⁾	R_{thJSP}	–	10	–	K/W	–
4.3.7	Junction to Ambient ¹⁾	R_{thJA}	–	140	–	K/W	Footprint only ²⁾
4.3.8			–	63	–	K/W	300 mm ² PCB heat sink area ²⁾
4.3.9			–	53	–	K/W	600 mm ² PCB heat sink area ²⁾
4.3.10			–	47	–	K/W	2s2p PCB ³⁾

1) Not subject to production test, specified by design

2) Specified R_{thJA} value is according to JEDEC JESD 51-3 at natural convection on FR4 1s0p board; The Product (Chip+Package) was simulated on a 76.2 × 114.3 × 1.5 mm³ board with 1 copper layer (1 x 70µm Cu).

3) Specified R_{thJA} value is according to Jedec JESD51-2,-5,-7 at natural convection on FR4 2s2p board; The Product (Chip+Package) was simulated on a 76.2 x 114.3 x 1.5 mm board with 2 inner copper layers (2 x 70µm Cu, 2 x 35µm Cu). Where applicable a thermal via array under the exposed pad contacted the first inner copper layer.

5 Voltage Regulator

5.1 Description Voltage Regulator

The output voltage V_Q is controlled by comparing a portion of it to an internal reference and driving a PNP pass transistor accordingly. Saturation control as a function of the load current prevents any oversaturation of the pass element. The control loop stability depends on the output capacitor C_Q , the load current, the chip temperature and the poles/zeros introduced by the integrated circuit. To ensure stable operation, the output capacitor's capacitance and its equivalent series resistor ESR requirements given in the table “**Functional Range**” on Page 10 have to be maintained. For details see also the typical performance graph “Output Capacitor Series Resistor ESR_{CQ} vs. Output Current I_Q ”. Also, the output capacitor shall be sized to buffer load transients.

An input capacitor C_1 is not needed for the control loop stability, but recommended to buffer line influences. Connect the capacitors close to the IC terminals.

Protection circuitry prevent the IC as well as the application from destruction in case of catastrophic events. These safeguards contain output current limitation, reverse polarity protection as well as thermal shutdown in case of overtemperature.

In order to avoid excessive power dissipation that could never be handled by the pass element and the package, the maximum output current is decreased at input voltages above $V_I = 22\text{ V}$.

The thermal shutdown circuit prevents the IC from immediate destruction under fault conditions (e.g. output continuously short-circuited) by switching off the power stage. After the chip has cooled down, the regulator restarts. This leads to an oscillatory behavior of the output voltage until the fault is removed. However, a junction temperature above 150 °C is outside the maximum rating and therefore reduces the IC lifetime.

The TLE4699 allows a negative supply voltage. However, several small currents are flowing into the IC increasing its junction temperature. This has to be considered for the thermal design, respecting that the thermal protection circuit is not operating during reverse polarity condition.

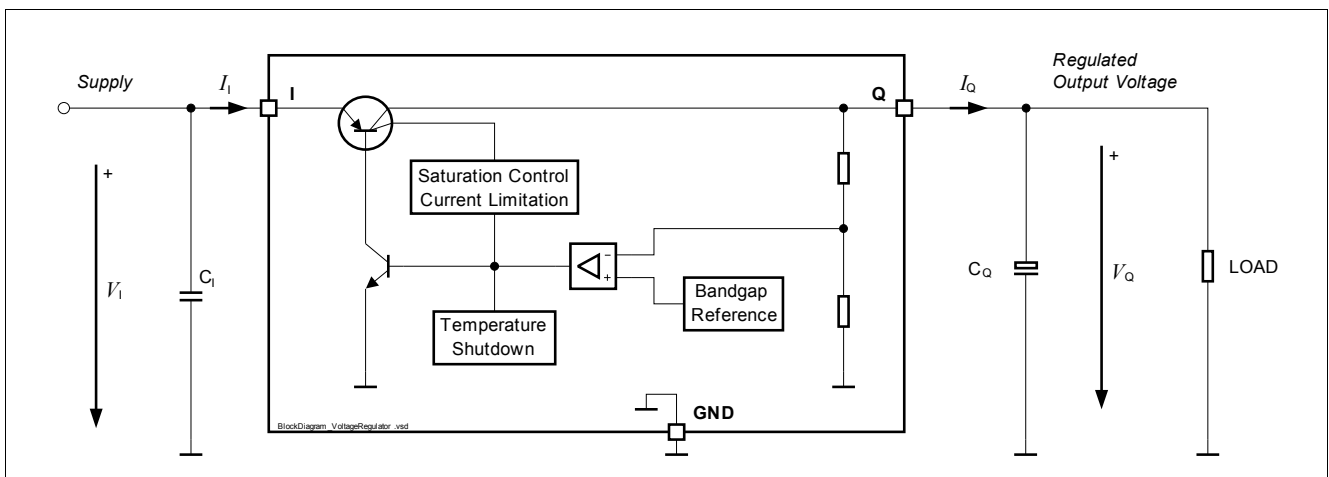

Figure 4 Block Diagram Voltage Regulator Circuit

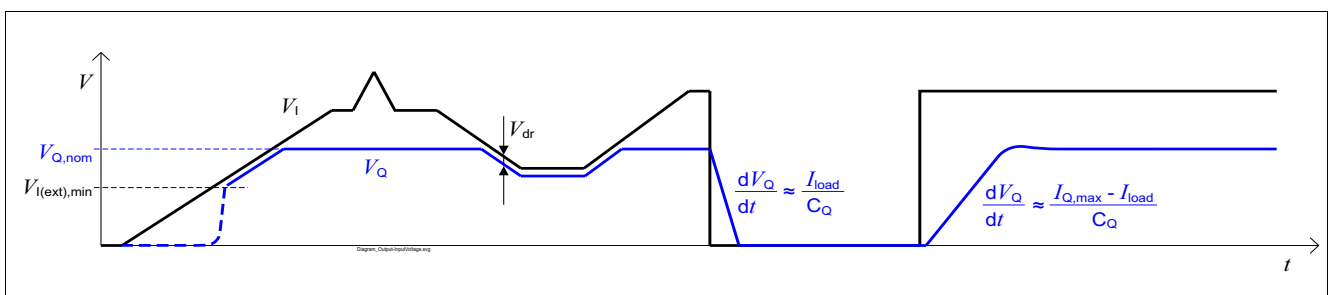

Figure 5 Output Voltage vs. Input Voltage

5.2 Electrical Characteristics Voltage Regulator

Electrical Characteristics: Voltage Regulator

$V_I = 13.5 \text{ V}$, $T_j = -40 \text{ }^\circ\text{C}$ to $+150 \text{ }^\circ\text{C}$,

all voltages with respect to ground, direction of currents as shown in **Figure 4** (unless otherwise specified)

Pos.	Parameter	Symbol	Limit Values			Unit	Conditions
			Min.	Typ.	Max.		
5.2.1	Output Voltage	V_Q	4.9	5.0	5.1	V	$0 \text{ mA} \leq I_Q \leq 200 \text{ mA}$; $8 \text{ V} \leq V_I \leq 18 \text{ V}$
5.2.2							$0 \text{ mA} \leq I_Q \leq 150 \text{ mA}$; $6 \text{ V} \leq V_I \leq 18 \text{ V}$
5.2.3							$0 \text{ mA} \leq I_Q \leq 100 \text{ mA}$; $18 \text{ V} \leq V_I \leq 32 \text{ V}$ $T_j \leq 105 \text{ }^\circ\text{C}$ ^{1) 2)}
5.2.4							$0 \text{ mA} \leq I_Q \leq 10 \text{ mA}$; $32 \text{ V} \leq V_I \leq 45 \text{ V}$ $T_j \leq 105 \text{ }^\circ\text{C}$ ^{1) 2)}
5.2.5							$0.3 \text{ mA} \leq I_Q \leq 100 \text{ mA}$; $18 \text{ V} \leq V_I \leq 32 \text{ V}$ ¹⁾
5.2.6							$0.3 \text{ mA} \leq I_Q \leq 10 \text{ mA}$; $32 \text{ V} \leq V_I \leq 45 \text{ V}$ ¹⁾
5.2.7	Load Regulation steady-state	$ dV_{Q,load} $	–	5	30	mV	$I_Q = 1 \text{ mA}$ to 150 mA ; $V_I = 6 \text{ V}$
5.2.8	Line Regulation steady-state	$ dV_{Q,line} $	–	2	20	mV	$V_I = 6 \text{ V}$ to 32 V ; $I_Q = 5 \text{ mA}$
5.2.9	Power Supply Ripple Rejection	$PSRR$	60	65	–	dB	$f_{ripple} = 100 \text{ Hz}$; $V_{ripple} = 1 \text{ Vpp}$ ²⁾
5.2.10	Drop out Voltage	V_{dr}	–	90	200	mV	$I_Q = 50 \text{ mA}$ ³⁾
5.2.11			$V_{dr} = V_I - V_Q$	–	160	350	mV
5.2.12	Output Current Limitation	$I_{Q,max}$	201	350	500	mA	$0 \text{ V} \leq V_Q \leq 4.8 \text{ V}$
5.2.13	Reverse Current	I_Q	-1.5	-0.7	–	mA	$V_I = 0 \text{ V}$; $V_Q = 5 \text{ V}$
5.2.14	Reverse Current at Negative Input Voltage	I_I	-2	-1	–	mA	$V_I = -16 \text{ V}$; $V_Q = 0 \text{ V}$
5.2.15			-5	-3,5	–	mA	$V_I = -42 \text{ V}$; $V_Q = 0 \text{ V}$
5.2.16	Overtemperature Shutdown Threshold	$T_{j,sd}$	151	–	200	$^\circ\text{C}$	T_j increasing ²⁾
5.2.17	Overtemperature Shutdown Threshold Hysteresis	$T_{j,hy}$	–	20	–	K	T_j decreasing ²⁾

1) See typical performance graph for details.

2) Parameter not subject to production test; specified by design.

3) Measured when the output voltage V_Q has dropped 100 mV from its nominal value.

5.3 Typical Performance Characteristics Voltage Regulator

Output Voltage V_Q vs. Junction Temperature T_j

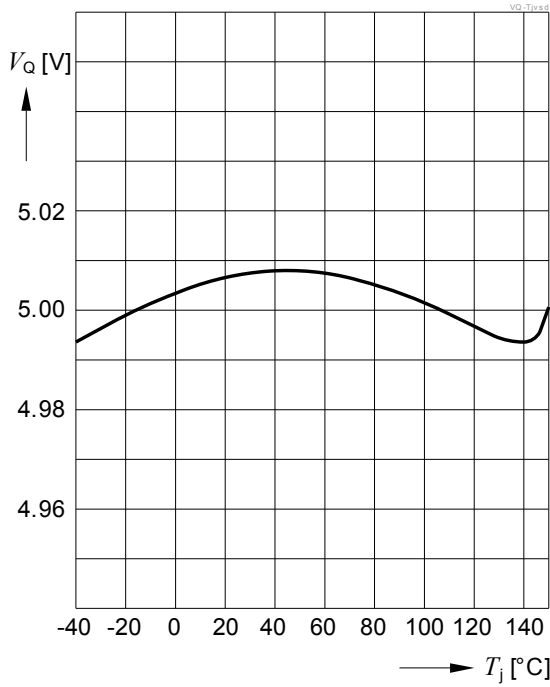

Output Capacitor Series Resistor ESR_{CQ} vs. Output Current I_Q

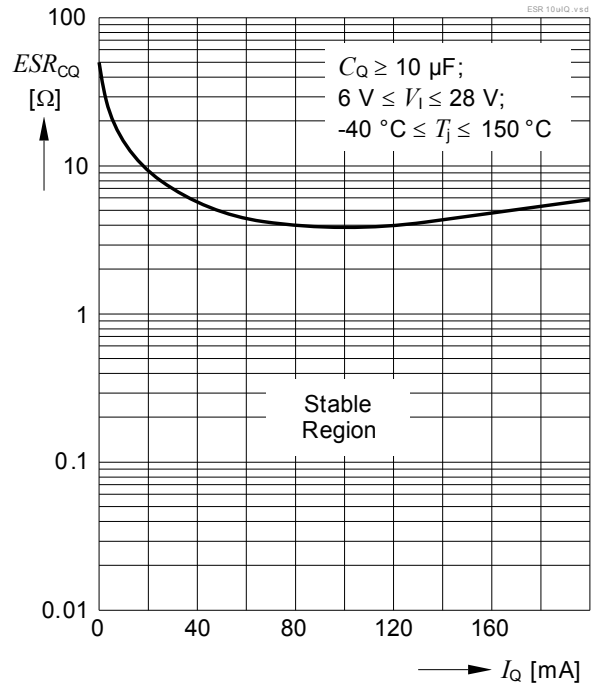

Output Current Limitation $I_{Q,max}$ vs. Input Voltage V_I

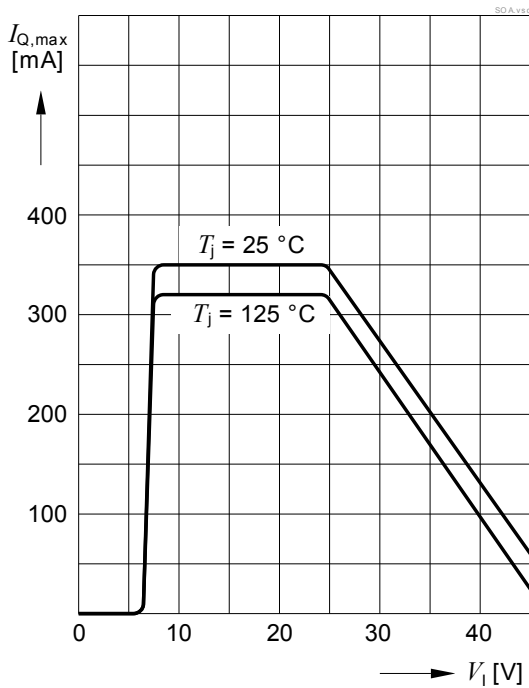

Dropout Voltage V_{dr} vs. Output Current I_Q

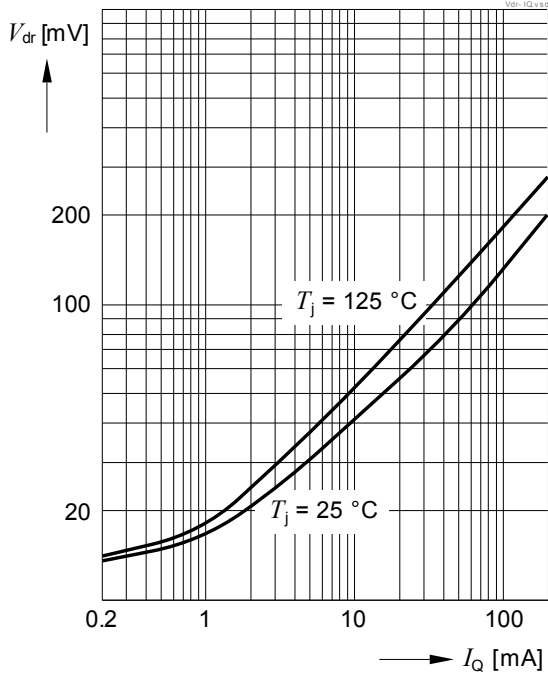

Dropout Voltage V_{dr} vs. Junction Temperature T_j

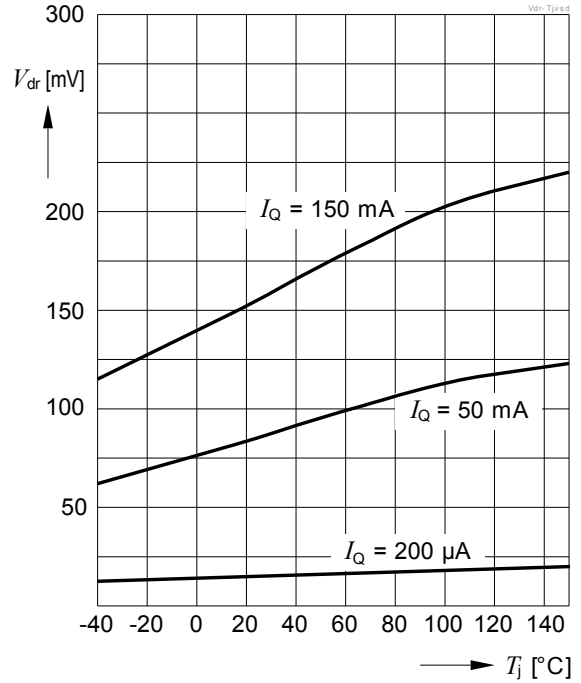

Reverse Output Current I_Q vs. Output Voltage V_Q

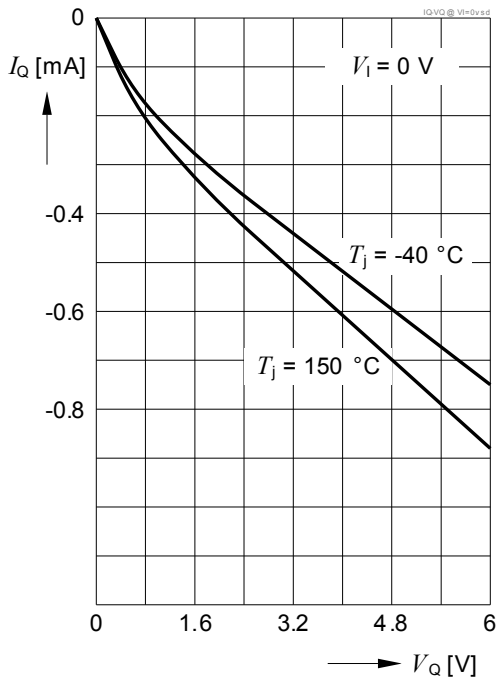

Reverse Current I_I vs. Input Voltage V_I

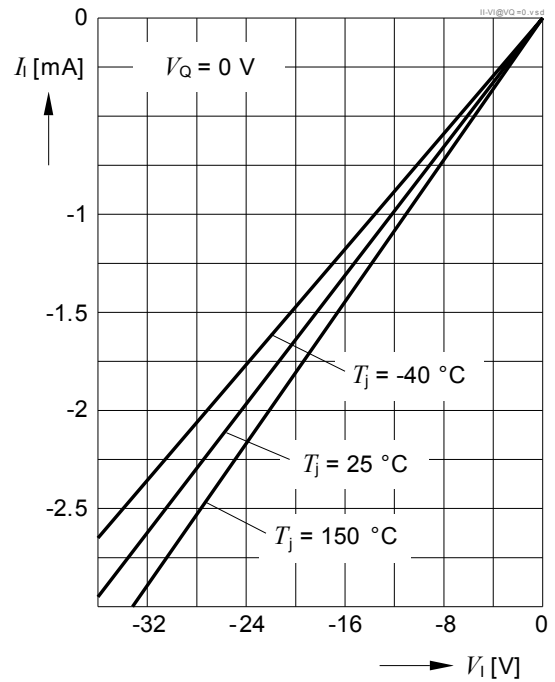

6 Current Consumption

6.1 Electrical Characteristics Current Consumption

Electrical Characteristics: Current Consumption

$V_1 = 13.5\text{ V}$, $T_j = -40\text{ °C}$ to $+150\text{ °C}$, all voltages with respect to ground, direction of currents as shown in [Figure 6 “Parameter Definition” on Page 18](#) (unless otherwise specified)

Pos.	Parameter	Symbol	Limit Values			Unit	Conditions
			Min.	Typ.	Max.		
6.1.1	Current Consumption $I_q = I_1 - I_Q$	$I_{q,on}$	–	65	100	μA	$I_Q \leq 200\ \mu\text{A}$; $T_j \leq 25\text{ °C}$ Enable on
6.1.2			–	80	105	μA	$I_Q \leq 200\ \mu\text{A}$; $T_j \leq 85\text{ °C}$ Enable on
6.1.3			–	1.0	2.0	mA	$I_Q = 50\text{ mA}$ Enable on
6.1.4			–	5	10	mA	$I_Q = 150\text{ mA}$ Enable on
6.1.5	Current Consumption $I_{q,off} = I_1$	$I_{q,off}$	–	–	1	μA	$T_j \leq 25\text{ °C}$ $V_{EN} = 0\text{V}$
6.1.6			–	–	2	μA	$T_j \leq 85\text{ °C}$ $V_{EN} = 0\text{V}$

6.2 Typical Performance Characteristics Current Consumption

Current Consumption I_q vs. Junction Temperature T_j

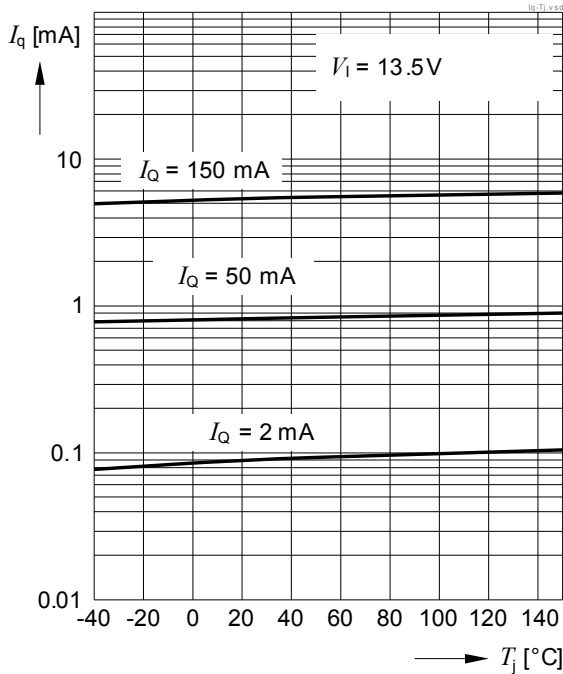

Current Consumption I_q vs. Junction Temperature T_j

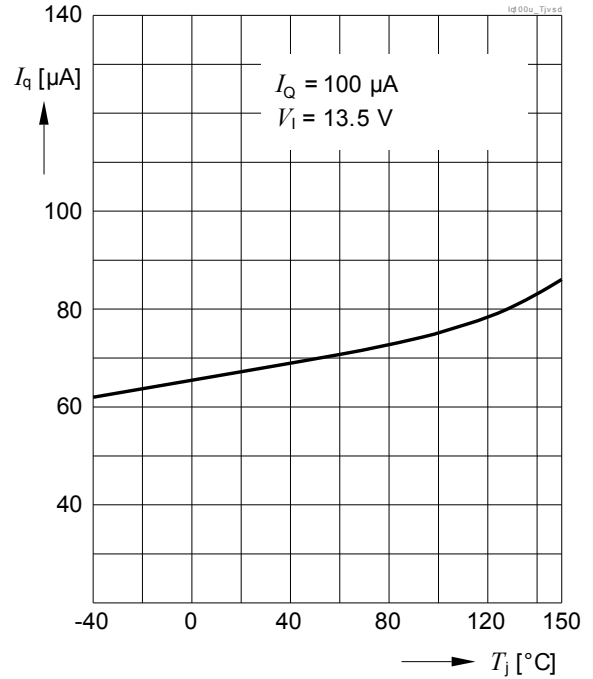

Current Consumption I_q vs. Output Current I_Q

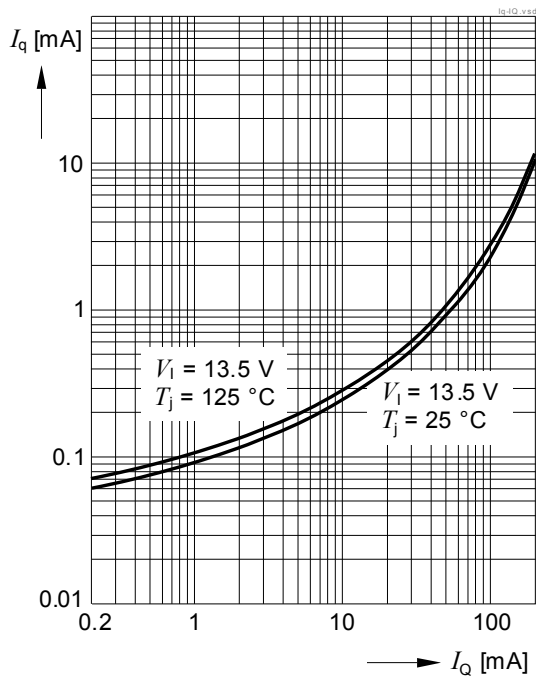

Current Consumption I_q vs. Input Voltage V_1

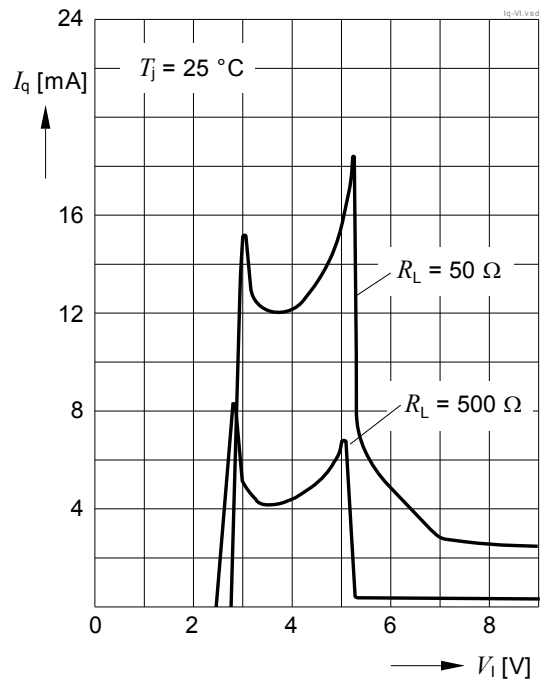

7 Enable Function

7.1 Description Enable Function

The TLE4699 can be turned on or turned off via the EN Input. With voltage levels higher than $V_{EN,high}$ applied to the EN Input the device will be completely turned on. A voltage level lower than $V_{EN,low}$ sets the device to low quiescent current mode. In this condition the device is turned off and is not functional. The Enable Input has an build in hysteresis to avoid toggling between ON/OFF state, if signals with slow slope are applied to the input.

7.2 Electrical Characteristics Enable Function

Electrical Characteristics: Enable Function

$V_I = 13.5\text{ V}$, $T_j = -40\text{ }^\circ\text{C}$ to $+150\text{ }^\circ\text{C}$, all voltages with respect to ground, direction of currents as shown in [Figure 6](#) (unless otherwise specified)

Pos.	Parameter	Symbol	Limit Values			Unit	Conditions
			Min.	Typ.	Max.		
7.2.1	Enable Low Signal Valid	$V_{EN,low}$	–	–	0.8	V	–
7.2.2	Enable High Signal Valid	$V_{EN,high}$	2.4	–	–	V	$V_Q > V_{Q,min}$
7.2.3	Enable Threshold Hysteresis	$V_{EN,hyst}$	50	–	–	mV	–
7.2.4	Enable Input current	I_{EN}	–	1	2	μA	$V_{EN} = 5\text{ V}$
7.2.5	Enable internal pull-down resistor	R_{EN}	3.2	4.7	6.2	$\text{M}\Omega$	–

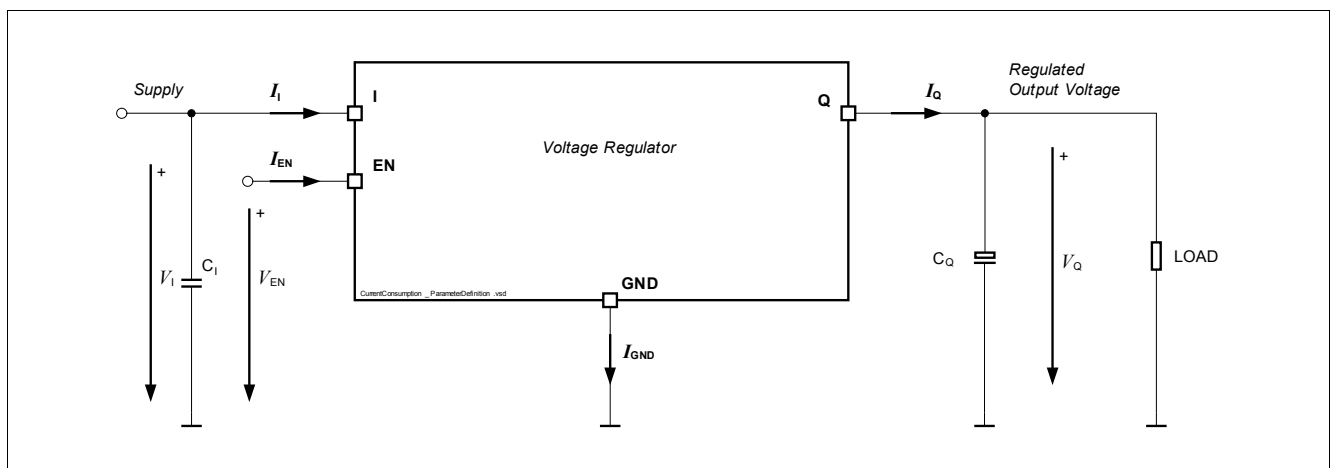
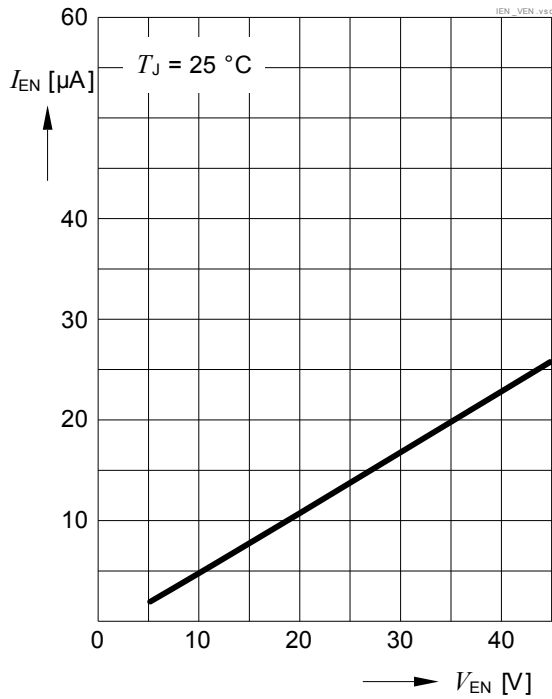

Figure 6 Parameter Definition

7.3 Typical Performance Characteristics Enable Input

Enable Input Current I_{EN} vs.
Enable Input Voltage V_{EN}



Enable Input Current vs.
Junction Temperature T_J

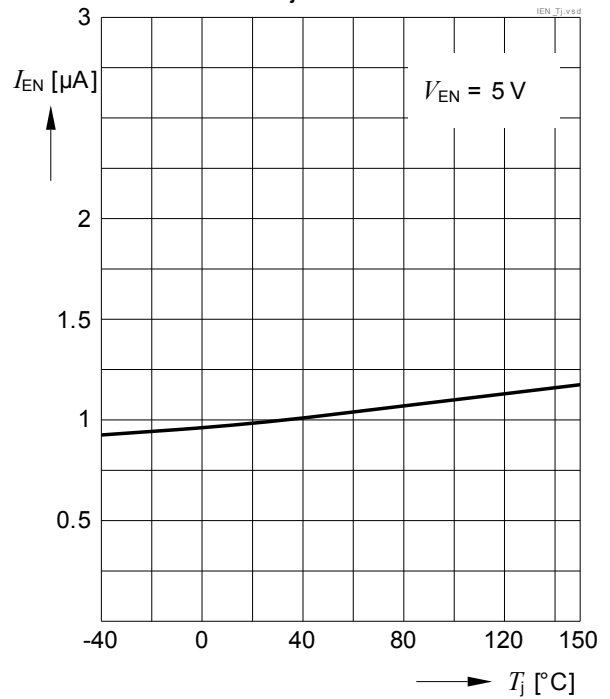

8 Reset Function

8.1 Description Reset Function

The reset function contains several features:

Output Undervoltage Reset:

An output undervoltage condition is indicated by setting the reset output “RO” to “low”. This signal might be used to reset a microcontroller during a low supply voltage condition.

Power-On Reset Delay Time

The power-on reset delay time $t_{d,PWR-ON}$ allows a microcontroller and oscillator to start up. This delay time is the time period from exceeding the upper reset switching threshold $V_{RT,hi}$ until the reset is released by switching the reset output “RO” from “low” to “high”. The power-on reset delay time $t_{d,PWR-ON}$ is defined by an external delay capacitor C_D connected to pin “D”, which is charged up by the delay capacitor charge current $I_{D,ch}$ starting from $V_D = 0$ V.

In case a power-on reset delay time $t_{d,PWR-ON}$ different from the value for $C_D = 100$ nF is required, the delay capacitor’s value can be derived from the specified value given in [Item 8.2.15](#):

$$C_D = \frac{t_{d,PWR-ON}}{t_{d,PWR-ON,100nF}} \times 100\text{nF}$$

with

- $t_{d,PWR-ON}$: Desired power-on reset delay time
- $t_{d,PWR-ON,100nF}$: Power-on reset delay time specified in [Item 8.2.15](#)
- C_D : Delay capacitor required

The formula is valid for $C_D \geq 10$ nF. For a precise calculation consider also the delay capacitor’s tolerance.

Undervoltage Reset Delay Time

Unlike the power-on reset delay time, the undervoltage reset delay t_d time considers a short output undervoltage event, where the delay capacitor C_D is assumed to be discharged to $V_D = V_{DST,lo}$ only before the charging sequence starts. Therefore, the undervoltage reset delay time t_d is defined by the delay capacitor charge current $I_{D,ch}$ starting from $V_D = V_{DST,lo}$ and the external delay capacitor C_D .

A delay capacitor C_D for a different undervoltage reset delay time as specified in [Item 8.2.14](#) can be calculated similar as above:

$$C_D = \frac{t_d}{t_{d,100nF}} \times 100\text{nF}$$

with

- t_d : Desired reset delay time
- $t_{d,100nF}$: Reset delay time specified in [Item 8.2.14](#)
- C_D : Delay capacitor required

The formula is valid for $C_D \geq 10$ nF. For a precise calculation consider also the delay capacitor’s tolerance.

Reset Reaction Time

In case the output voltage of the regulator drops below the output undervoltage lower reset threshold $V_{RT,lo}$, the delay capacitor C_D is discharged rapidly. Once the delay capacitor's voltage has reached the lower delay switching threshold $V_{DST,lo}$, the reset output RO will be set to "low".

Additionally to the delay capacitor discharge time $t_{rr,d}$ an internal time $t_{rr,int}$ applies. Hence the total reset reaction time $t_{rr,total}$ becomes:

$$t_{rr,total} = t_{rr,int} + t_{rr,d}$$

with

- $t_{rr,total}$: total reset reaction time
- $t_{rr,int}$: Internal reset reaction time; see [Item 8.2.16](#)
- $t_{rr,d}$: Delay capacitor discharge time. For a capacitor C_D different from the value specified in [Item 8.2.17](#), see typical performance graphs.

Reset Output "RO"

The reset output "RO" is an open collector output with an integrated pull-up resistor. In case a lower-ohmic "RO" signal is desired, an external pull-up resistor to the output "Q" can be connected. Since the maximum "RO" sink current is limited, the optional external resistor $R_{RO,ext}$ must not be below as specified in [Item 8.2.8](#).

Reset Output "RO" Low for $V_Q \geq 1\text{ V}$

In case of an undervoltage reset condition reset output "RO" is held "low" for $V_Q \geq 1\text{ V}$, even if the input voltage V_I is 0 V. This is achieved by supplying the reset circuit from the output capacitor.

Reset Adjust Function

The undervoltage reset switching threshold can be adjusted according to the application's needs by connecting an external voltage divider ($R_{ADJ,1}$, $R_{ADJ,2}$) at pin "RADJ". For selecting the default threshold connect pin "RADJ" to GND. The reset adjustment range is given in [Item 8.2.6](#).

When dimensioning the voltage divider, take into consideration that there will be an additional current constantly flowing through the resistors.

With a voltage divider connected, the reset switching threshold $V_{RT,new}$ is calculated as follows

$$V_{RT,new} = V_{RADJ,th} \times \frac{R_{ADJ,1} + R_{ADJ,2}}{R_{ADJ,2}}$$

with

- $V_{RT,new}$: Desired reset switching threshold.
- $R_{ADJ,1}$, $R_{ADJ,2}$: Resistors of the external voltage divider, see [Figure 7](#).
- $V_{RADJ,th}$: Reset adjust switching threshold given in [Item 8.2.5](#).

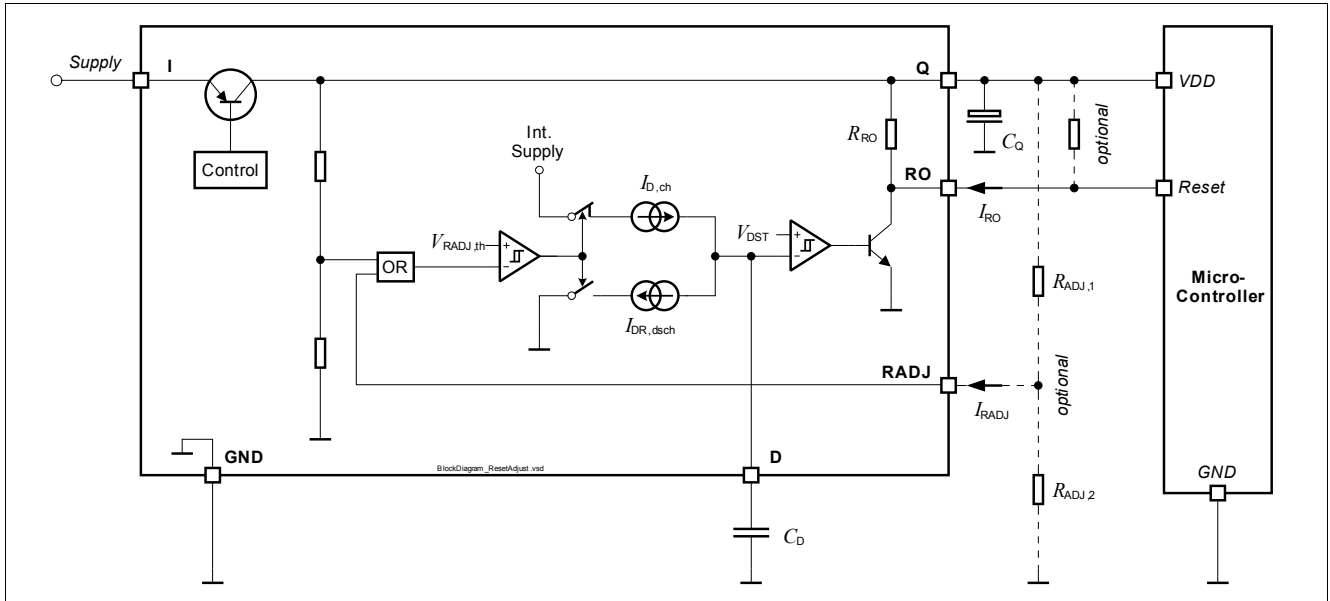

Figure 7 Block Diagram Reset Circuit

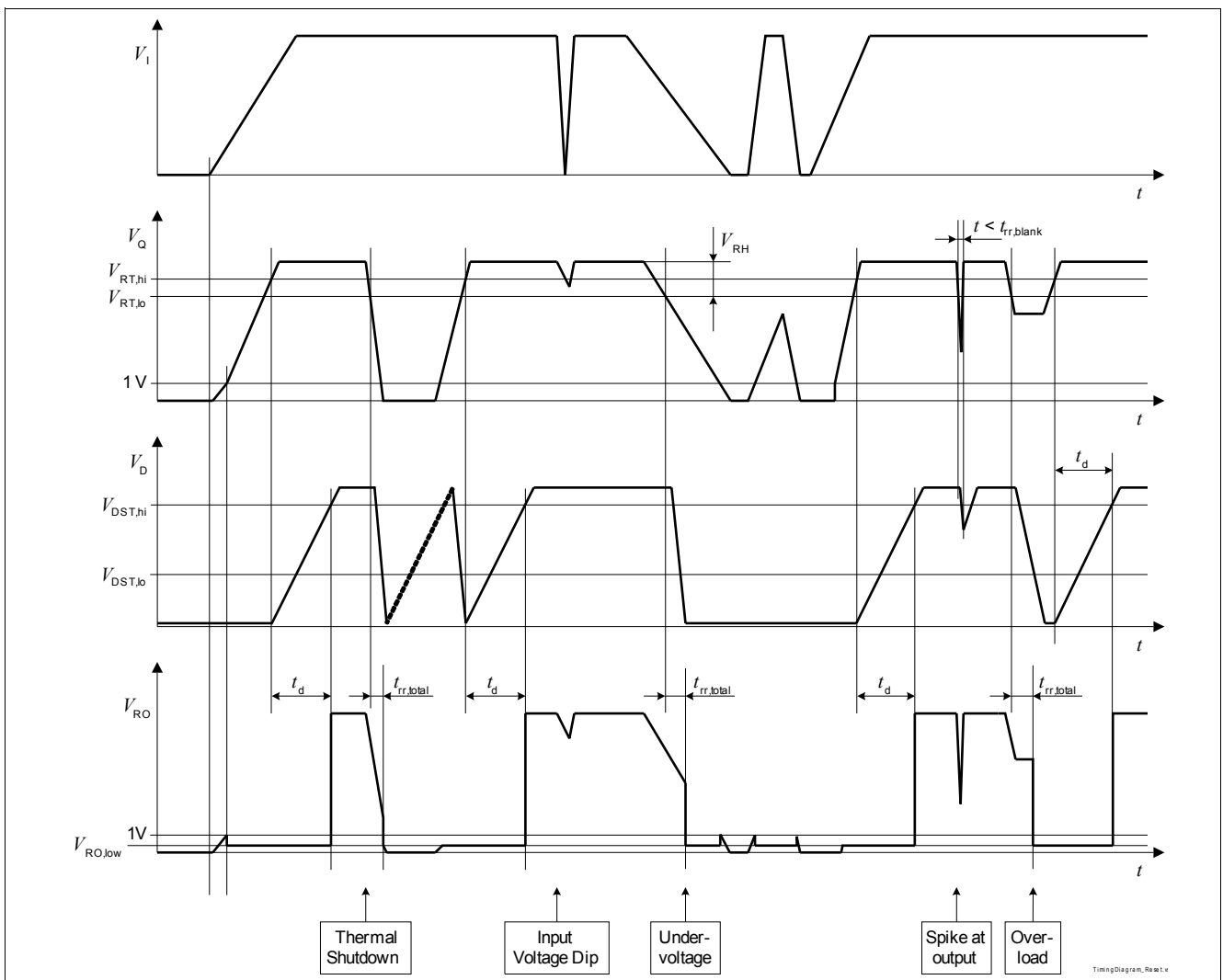

Figure 8 Timing Diagram Reset

8.2 Electrical Characteristics Reset Function

Electrical Characteristics: Reset Function

$V_I = 13.5\text{ V}$, $T_j = -40\text{ °C}$ to $+150\text{ °C}$,

all voltages with respect to ground, direction of currents as shown in **Figure 7** (unless otherwise specified).

Pos.	Parameter	Symbol	Limit Values			Unit	Conditions
			Min.	Typ.	Max.		

Output Undervoltage Reset Comparator Default Values (Pin RADJ = GND)

8.2.1	Output Undervoltage Reset Lower Switching Threshold	$V_{RT,lo}$	4.6	4.7	4.8	V	$V_I = 0\text{ V}$ V_Q decreasing RADJ = GND
8.2.2	Output Undervoltage Reset Upper Switching Threshold	$V_{RT,hi}$	4.7	4.8	4.9	V	V_I within operating range V_Q increasing RADJ = GND
8.2.3	Output Undervoltage Reset Switching Hysteresis	$V_{RT,hy}$	60	120	–	mV	V_I within operating range RADJ = GND.
8.2.4	Output Undervoltage Reset Headroom	V_{RH}	250	300	–	mV	Calculated Value: $V_Q - V_{RT,lo}$ V_I within operating range $I_Q = 50\text{ mA}$ RADJ = GND

Reset Threshold Adjustment

8.2.5	Reset Adjust Lower Switching Threshold	$V_{RADJ,th}$	1.17	1.195	1.22	V	$V_I = 0\text{ V}$ $3.2\text{ V} \leq V_Q < 5\text{ V}$
8.2.6	Reset Adjustment Range ¹⁾	$V_{RT,range}$	3.20	–	4.70	V	–

Reset Output RO

8.2.7	Reset Output Low Voltage	$V_{RO,low}$	–	0.2	0.4	V	$V_I = 0\text{ V}$; $1\text{ V} \leq V_Q \leq V_{RT,low}$ $R_{RO,ext} = 3.3\text{ k}\Omega$
8.2.8	Reset Output External Pull-up Resistor to Q	$R_{RO,ext}$	3	–	–	k Ω	$V_I = 0\text{ V}$; $1\text{ V} \leq V_Q \leq V_{RT,low}$ $V_{RO} = 0.4\text{ V}$
8.2.9	Reset Output Internal Pull-up Resistor	R_{RO}	20	30	40	k Ω	internally connected to Q

Reset Delay Timing

8.2.10	Upper Delay Switching Threshold	$V_{DST,hi}$	–	1.21	–	V	–
8.2.11	Lower Delay Switching Threshold	$V_{DST,lo}$	–	0.30	–	V	–
8.2.12	Delay Capacitor Charge Current	$I_{D,ch}$	–	3.5	–	μA	$V_D = 1\text{ V}$
8.2.13	Delay Capacitor Reset Discharge Current	$I_{DR,dsch}$	–	80	–	mA	$V_D = 1\text{ V}$
8.2.14	Undervoltage Reset Delay Time	$t_{d,100nF}$	16	23	30	ms	Calculated value; $C_D = 100\text{ nF}$ ²⁾ ; C_D discharged to $V_{DST,lo}$

Electrical Characteristics: Reset Function (cont'd)

$V_I = 13.5\text{ V}$, $T_j = -40\text{ °C}$ to $+150\text{ °C}$,

all voltages with respect to ground, direction of currents as shown in **Figure 7** (unless otherwise specified).

Pos.	Parameter	Symbol	Limit Values			Unit	Conditions
			Min.	Typ.	Max.		
8.2.15	Power-on Reset Delay Time	$t_{d,PWR-ON,100nF}$	20	31	40	ms	Calculated value; $C_D = 100\text{ nF}^{2)}$; C_D discharged to 0 V
8.2.16	Internal Reset Reaction Time	$t_{rr,int}$	–	9	15	μs	$C_D = 0\text{ nF}$
8.2.17	Delay Capacitor Discharge Time	$t_{rr,d,100nF}$	–	1.5	3	μs	$C_D = 100\text{ nF}^{2)}$
8.2.18	Total Reset Reaction Time	$t_{rr,total,100nF}$	–	10.5	18	μs	Calculated Value: $t_{rr,d,100nF} + t_{rr,int}$; $C_D = 100\text{ nF}^{2)}$

1) Related Parameters ($V_{RT,hi}$, $V_{RT,hy}$) are scaled linear when the Reset Switching Threshold is modified.

2) For programming a different delay and reset reaction time, see **Chapter 8.1**.

8.3 Typical Performance Characteristics Reset Function

Undervoltage Reset Switching Thresholds

$V_{RT,lo}$, $V_{RT,hi}$ vs. T_j

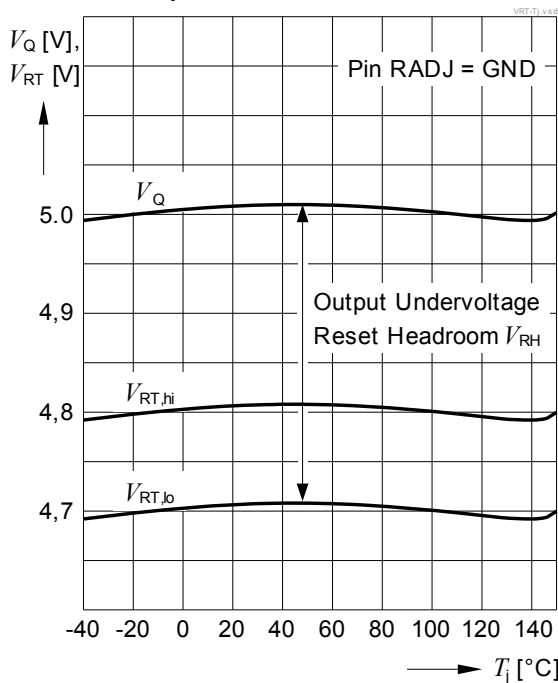

Reset Delay Time t_d , $t_{d,PWR-ON}$ vs. Delay Capacitor C_D

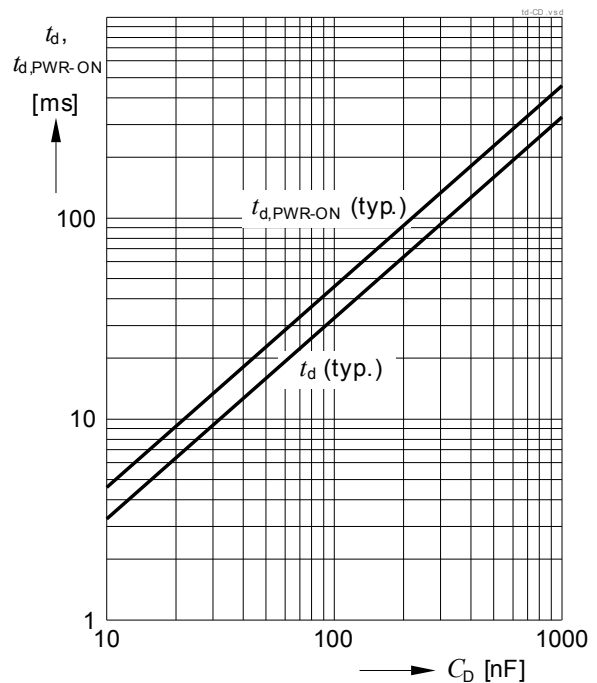

9 Early Warning Function

9.1 Description Early Warning Function

The additional sense comparator provides an early warning function: Any voltage (e.g. the input voltage) can be monitored, an undervoltage condition is indicated by setting the comparator's output to low. The use of an external voltage divider makes this comparator very flexible in the application.

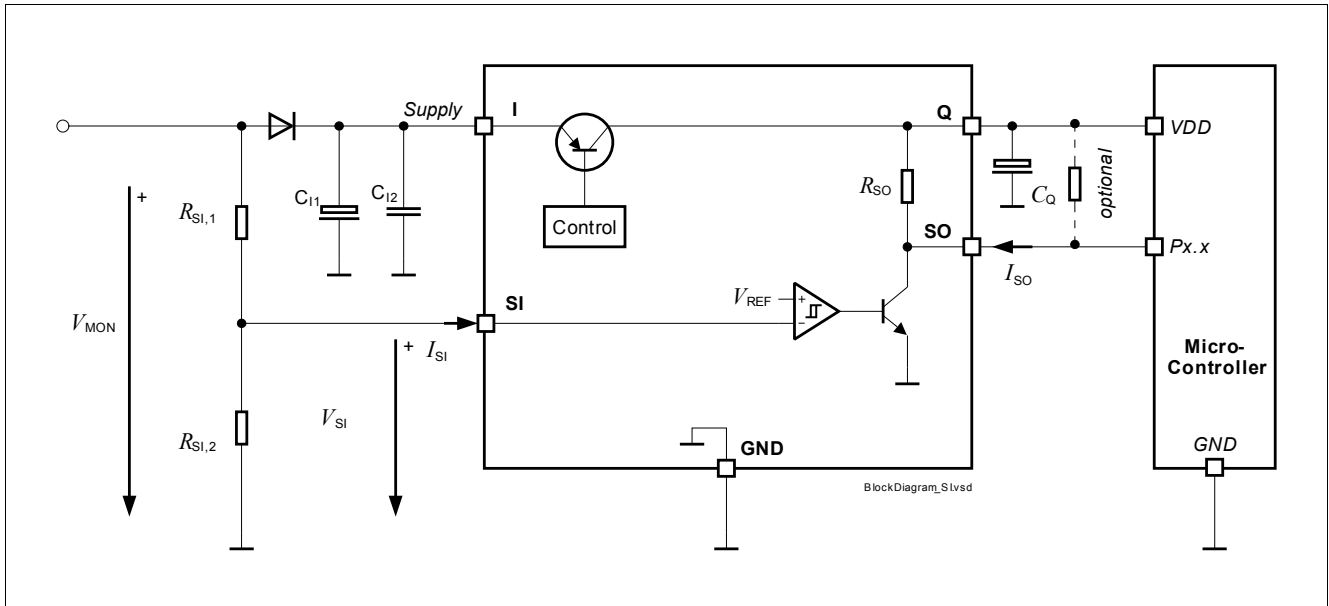

Figure 9 Diagram

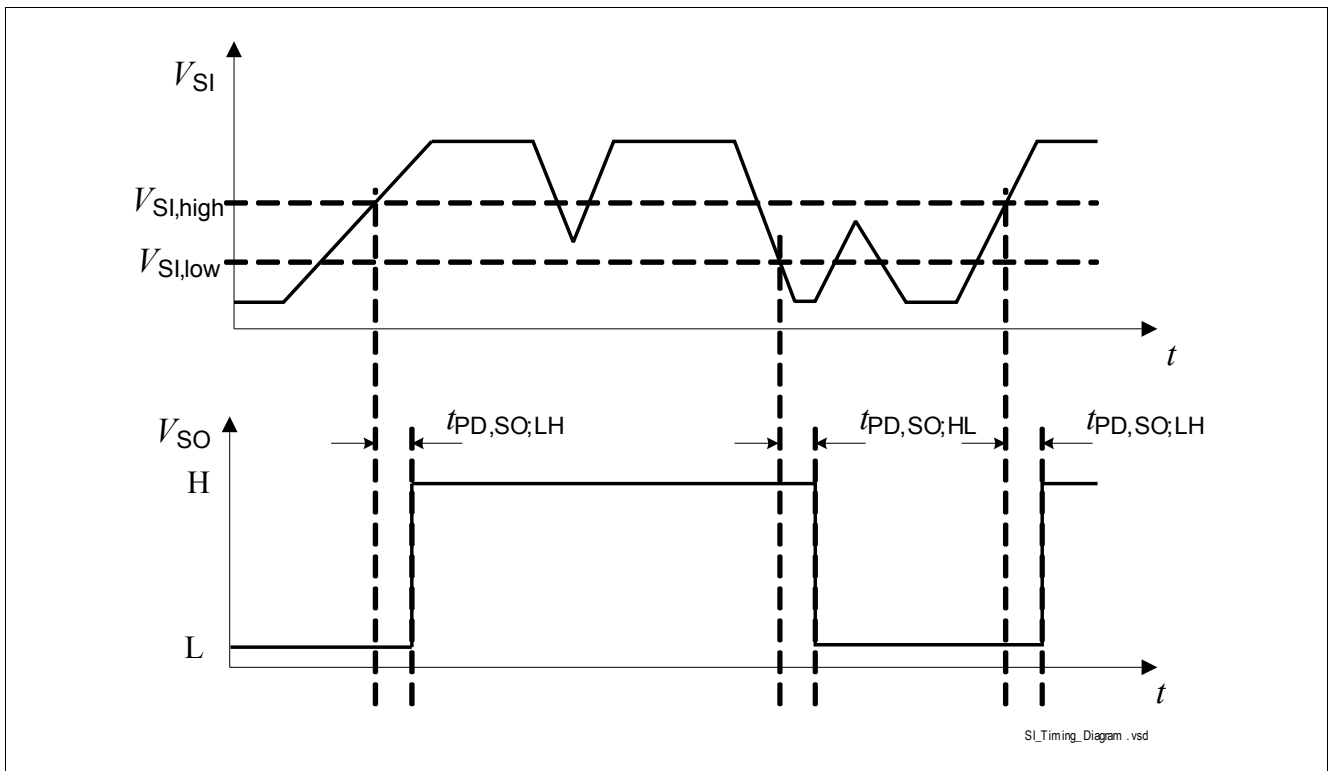

Figure 10 Timing Diagram

Early Warning Resistor Divider Adjust

The switching threshold can be set to the application's needs by connecting an external voltage divider ($R_{SI,1}$, $R_{SI,2}$) at pin "SI". If the Early Warning function is not needed, it is recommend to connect the SI pin to the output voltage pin Q.

When dimensioning the voltage divider, take into consideration that there will be an additional current constantly flowing through the resistors.

With a voltage divider connected, the upper switching threshold for the monitored voltage $V_{MON,high}$ is calculated as follows

$$V_{MON,high} = V_{SI,high} \times \frac{R_{SI,1} + R_{SI,2}}{R_{SI,2}}$$

with

- $V_{MON,high}$: Desired reset switching threshold.
- $R_{SI,1}$, $R_{SI,2}$: Resistors of the external voltage divider, see [Figure 9](#).
- $V_{SI,high}$: Sense threshold high given in [Item 9.2.1](#). The lower switching threshold for the monitored voltage

$V_{MON,low}$ is calculated as follows

$$V_{MON,low} = V_{SI,low} \times \frac{R_{SI,1} + R_{SI,2}}{R_{SI,2}}$$

with

- $V_{mon,high}$: Desired reset switching threshold.
- $R_{SI,1}$, $R_{SI,2}$: Resistors of the external voltage divider, see [Figure 9](#).
- $V_{SI,high}$: Reset adjust switching threshold given in [Item 9.2.2](#).

Sense Output "SO"

The sense output "SO" is an open collector output with an integrated pull-up resistor. In case a lower-ohmic "SO" signal is desired, an external pull-up resistor to the output "Q" can be connected.

9.2 Electrical Characteristics Early Warning Function

Electrical Characteristics: Early Warning Function

$V_I = 13.5\text{ V}$, $T_j = -40\text{ °C}$ to $+150\text{ °C}$, all voltages with respect to ground, direction of currents as shown in [Figure 9](#) (unless otherwise specified)

Pos.	Parameter	Symbol	Limit Values			Unit	Conditions
			Min.	Typ.	Max.		
Sense Comparator Input							
9.2.1	Sense threshold high	$V_{SI,high}$	1.22	1.25	1.28	V	–
9.2.2	Sense threshold low	$V_{SI,low}$	1.16	1.185	1.21	V	–
9.2.3	Sense input switching hysteresis	$V_{SI,hy}$	–	65	–	mV	–
9.2.4	Sense input current	I_{SI}	-1	0.1	1	μA	–
Sense Comparator Output							
9.2.5	Sense output low voltage	$V_{SO,low}$	–	0.2	0.4	V	–
9.2.6	Maximum sink current capability	$I_{SO,max}$	1.5	–	–	mA	–
9.2.7	Internal sense pull up resistor	R_{SO}	10	20	40	$\text{k}\Omega$	–
9.2.8	Sense high reaction time	$t_{PD,SO,HL}$	–	5	10	μs	–
9.2.9	Sense low reaction time	$t_{PD,SO,LH}$	–	5	10	μs	–

9.3 Typical Performance Characteristics Early Warning Function

Sense threshold V_{SI} vs. T_j

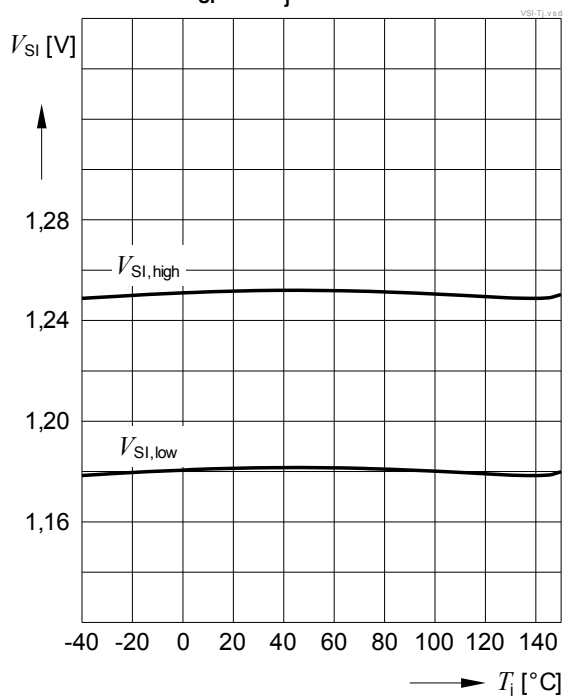

10 Package Outlines

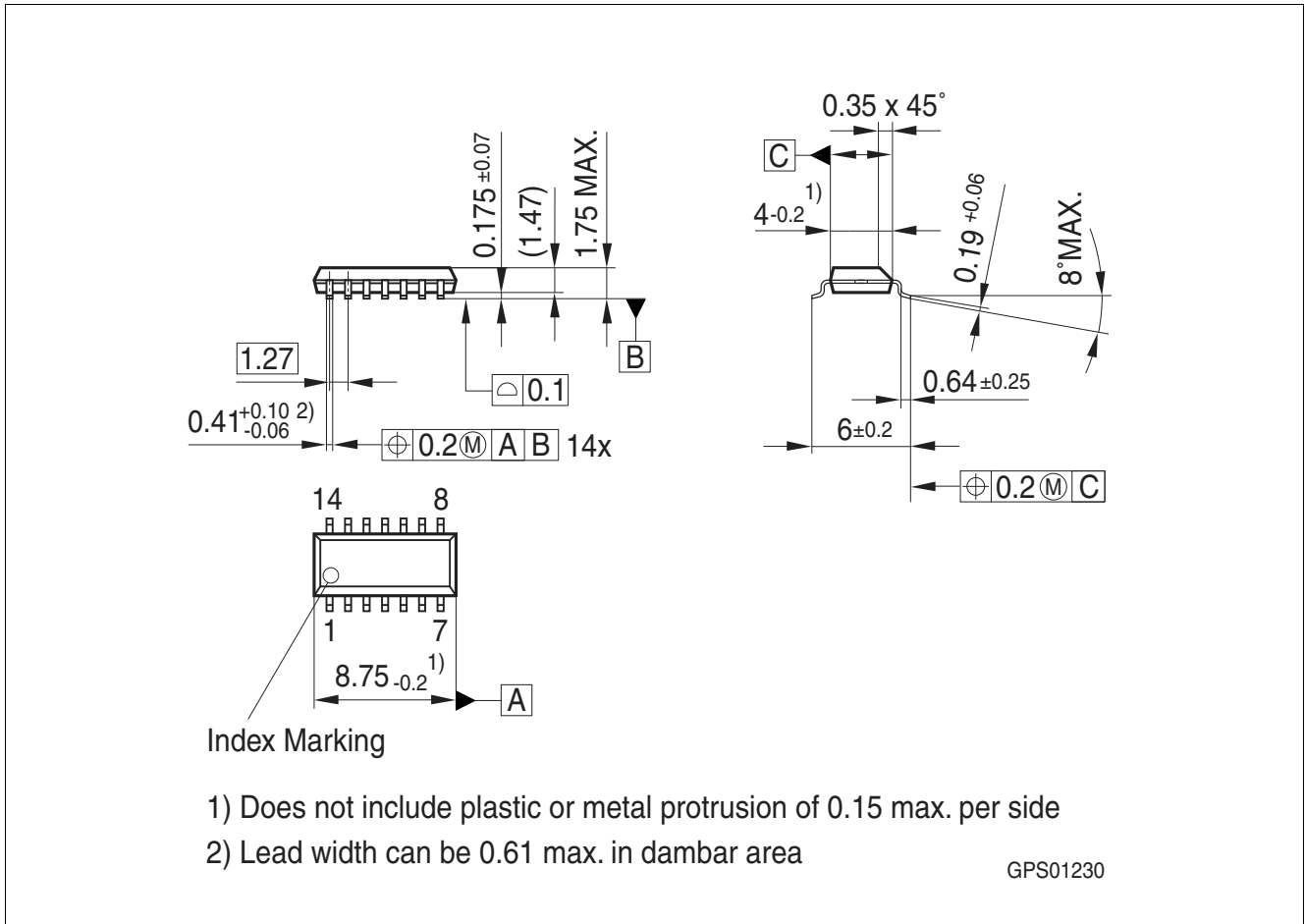

Figure 11 Outline PG-DSO-14

Green Product (RoHS compliant)

To meet the world-wide customer requirements for environmentally friendly products and to be compliant with government regulations the device is available as a green product. Green products are RoHS-Compliant (i.e Pb-free finish on leads and suitable for Pb-free soldering according to IPC/JEDEC J-STD-020).

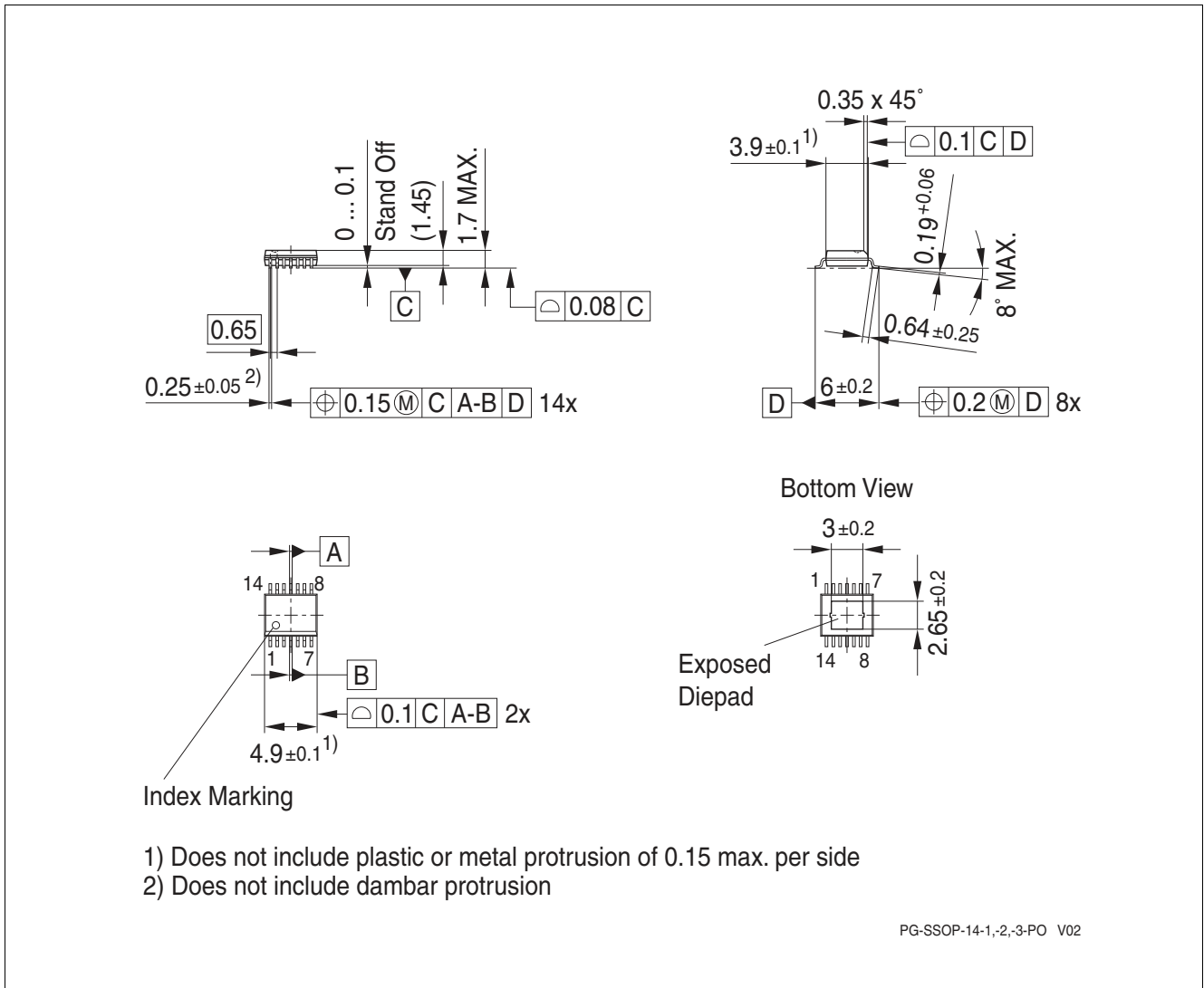

Figure 12 Outline PG-SSOP-14 EP

Green Product (RoHS compliant)

To meet the world-wide customer requirements for environmentally friendly products and to be compliant with government regulations the device is available as a green product. Green products are RoHS-Compliant (i.e Pb-free finish on leads and suitable for Pb-free soldering according to IPC/JEDEC J-STD-020).

For further information on packages, please visit our website:
<http://www.infineon.com/packages>.

Dimensions in mm

11 Revision History

Revision	Date	Changes
1.0	2010-11-30	Data sheet

Edition 2010-11-30

**Published by
Infineon Technologies AG
81726 Munich, Germany**

**© 2010 Infineon Technologies AG
All Rights Reserved.**

Legal Disclaimer

The information given in this document shall in no event be regarded as a guarantee of conditions or characteristics. With respect to any examples or hints given herein, any typical values stated herein and/or any information regarding the application of the device, Infineon Technologies hereby disclaims any and all warranties and liabilities of any kind, including without limitation, warranties of non-infringement of intellectual property rights of any third party.

Information

For further information on technology, delivery terms and conditions and prices, please contact the nearest Infineon Technologies Office (www.infineon.com).

Warnings

Due to technical requirements, components may contain dangerous substances. For information on the types in question, please contact the nearest Infineon Technologies Office.

Infineon Technologies components may be used in life-support devices or systems only with the express written approval of Infineon Technologies, if a failure of such components can reasonably be expected to cause the failure of that life-support device or system or to affect the safety or effectiveness of that device or system. Life support devices or systems are intended to be implanted in the human body or to support and/or maintain and sustain and/or protect human life. If they fail, it is reasonable to assume that the health of the user or other persons may be endangered.