

4

3

2

1

REVISIONS					
ZONE	LTR	ECN	DESCRIPTION	DATE	APPROVED
	P	24298	REVISED & REDRAWN 8-22-79 ORIGINAL RELEASE 12-25-59 M.F.M. AND G.P.F.	9/25/79	RAY
	R	36837	ITEM 7, WAS 003-006A-0000	3-31-97	ES
	S	38597	UPDATE REV LETTER	2/11/79	ES

CABLE ACCEPTANCE DIMENSIONS  
 JACKET DIA. .134 MAX  
 SHIELD DIA. .118 MAX  
 DIELECTRIC DIA. .100 MAX  
 INNER CONDUCTOR DIA. .015 MAX

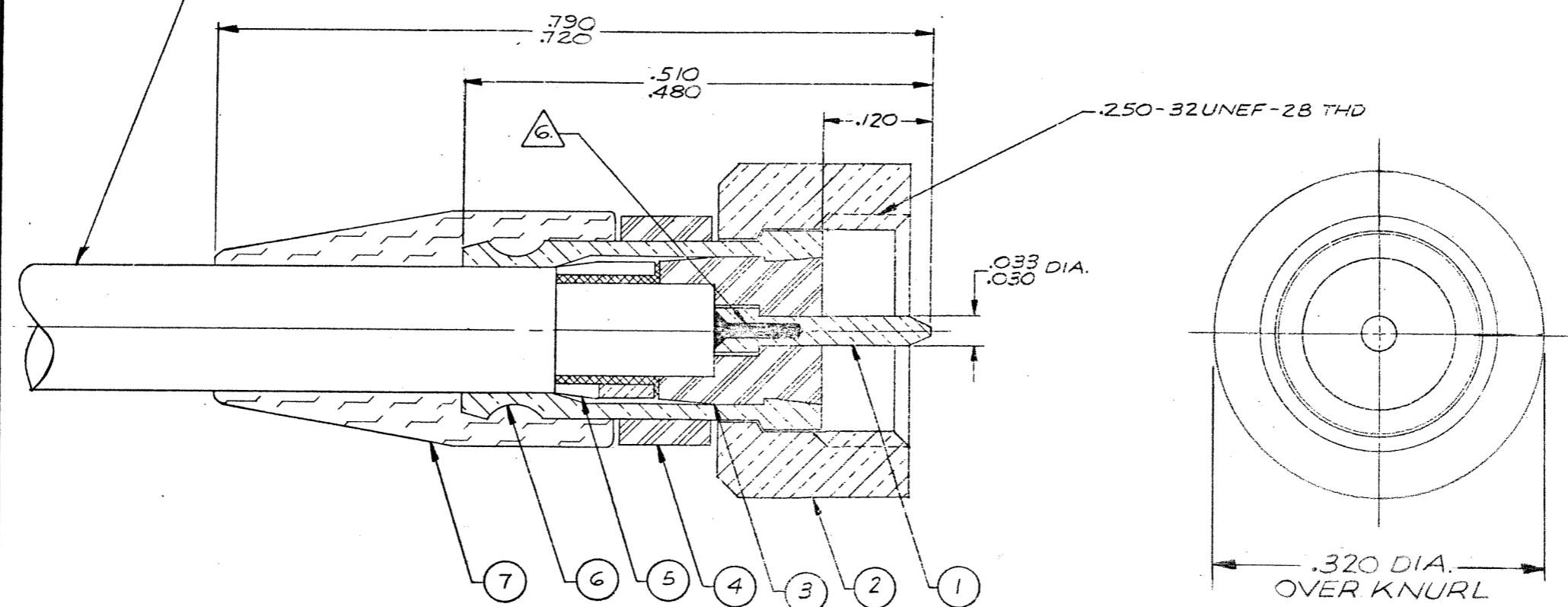

Tyco Dwg 1466114  
 Micro P/N 03200170001

- NOTES: UNLESS OTHERWISE SPECIFIED.
1. THIS CONNECTOR MATES WITH ALL S-93 JACKS AND RECEPTACLES AS LISTED IN MALCO CATALOG.
  2. FOR ASSEMBLY INSTRUCTIONS SEE RF-ASMB-95.
  3. MALCO ASSEMBLY TOOL # 010-0005-0000 REQ'D.
  4. SILVER PLATE .0002 MIN. PER QQ-S-365, TYPE II, GRADE A.
  5. GOLD PLATE PER MIL-G-45204, TYPE II, GRADE C, CLASS I.
  6. INNER CONDUCTOR SOLDERED TO PIN CONTACT.

QTY REQD	CODE IDENT	PART OR IDENTIFYING NO.	DESCRIPTION	MAT'L AND SPEC.	ITEM NO.
1		003-0272-0000	BEND RELIEF CAP	SILICONE RUBBER, ZZ-R-765	7
1		000-2501-0053	FERRULE	BRASS PER QQ-B-626	6
1		000-5301-0007	JERK RING	BRASS PER QQ-B-626	5
1		000-4801-0012	SLEEVE, PIN PROTECTOR	TEFLON PER L-P-403	4
1		000-0301-0125	INSULATOR	TEFLON PER L-P-403	3
1		000-2001-0053	NUT	BRASS PER QQ-B-626	2
1		003-0360-0002	CONTACT, PIN	BRASS PER QQ-B-626	1

UNLESS OTHERWISE SPECIFIED DIMENSIONS ARE IN INCHES TOLERANCES ARE: FRACTIONS DECIMALS ANGLES ± .XX ± .XXX ± .010		CONTRACT NO.		<b>MALCO</b> A MICRODOT COMPANY, INC. 220 PASADENA AVE., SO. PASADENA, CALIF. 91030	PROD. CODE
MATERIAL		APPROVALS	DATE		931
FINISH		DRAWN <i>Ray</i>	8-22-79		CORE
NEXT ASSY		CHECKED <i>Wally Kelly</i>	9-13-79		CDM
USED ON		PR. ENG. <i>RAY</i>	9-14-79	PLUG, STRAIGHT S-93 SERIES	
APPLICATION		APPD.	SIZE	CODE IDENT NO.	DRAWING NO.
DO NOT SCALE DRAWING		These drawings and specifications are the property of Microdot Inc. and shall not be produced or copied, or used as the basis for the manufacture or sale of any article without written permission of Microdot Inc.		B	98278 032-0017-0001

D

C

B

A