

MAX6279

0.1%, 25ppm, Ceramic Shunt Voltage Reference

General Description

The MAX6279 is a precision, two-terminal shunt mode, bandgap voltage reference available in fixed reverse breakdown voltage of 1.225V. Ideal for space-critical applications, the MAX6279 is offered in an 8-Pin ceramic package.

Laser-trimmed resistors ensure precise initial accuracy. With a 25ppm/°C temperature coefficient, the device is offered in three grades of initial accuracy ranging from 0.1% to 0.5%. The MAX6279 has a 70µA to 12mA shunt-current capability with low-dynamic impedance, ensuring stable reverse breakdown voltage accuracy over a wide range of operating temperatures and currents.

The MAX6279 does not require an external stabilizing capacitor while ensuring stability with capacitive loads. The MAX6279 is a higher precision device than the LM4040/LM4050.

Applications

- Portable, Battery-Powered Equipment
- Notebook Computers
- Cell Phones
- Industrial Process Control

Ordering Information appears at end of data sheet.

Benefits and Features

- 8-Pin Ceramic Package Reduces System Board Space
- Hermetically Sealed Ceramic Package Offers Stable Results vs. Time, Humidity and Temperature
- 0.1% (max) Initial Accuracy
- 25ppm/°C (max) Temperature Coefficient Guaranteed Over -40°C to +85°C Temperature Range
- Wide Operating Current Range: 70µA to 12mA
- Low 28µV_{RMS} Output Noise (10Hz to 10kHz)
- No Output Capacitors Required
- Stable with Capacitive Loads

Typical Operating Circuit

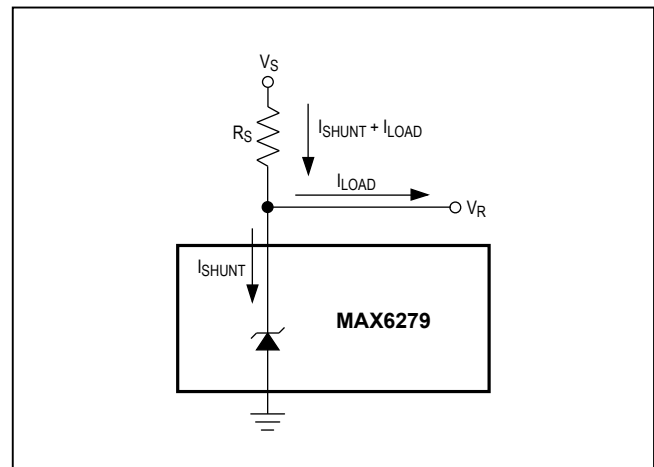

Absolute Maximum Ratings

Reverse Current (cathode to anode).....	20mA	Operating Temperature Range.....	-40°C to +85°C
Forward Current (anode to cathode).....	10mA	Storage Temperature Range.....	-65°C to +150°C
Continuous Power Dissipation (T _A = +70°C)		Junction Temperature.....	+150°C
8-Pin LCC (derate 10.3mW/°C above +70°C).....	387mW	Lead Temperature (soldering, 10s)	+300°C
		Soldering Temperature (reflow).....	+260°C

Stresses beyond those listed under "Absolute Maximum Ratings" may cause permanent damage to the device. These are stress ratings only, and functional operation of the device at these or any other conditions beyond those indicated in the operational sections of the specifications is not implied. Exposure to absolute maximum rating conditions for extended periods may affect device reliability.

Electrical Characteristics—MAX6279_12 (1.225V)

(I_R = 100µA, T_A = -40°C to +85°C, unless otherwise noted. Typical values are at T_A = +25°C.) (Note 1)

PARAMETER	SYMBOL	CONDITIONS		MIN	TYP	MAX	UNITS
Reverse Breakdown Voltage (Note 2)	V _R	T _A = +25°C	MAX6279A (0.1%)	1.22377	1.225	1.22623	V
Minimum Operating Current	I _{RMIN}				45	70	µA
Reverse Voltage Temperature Coefficient (Notes 2, 3)	TC				4	25	ppm/°C
Reverse Breakdown Voltage Change with Operating Current Change	ΔV _R /ΔI _R	I _{RMIN} ≤ I _R ≤ 1mA			0.3	1.0	mV
		1mA ≤ I _R ≤ 12mA			2.5	13.0	
Reverse Dynamic Impedance (Note 3)	Z _R	I _R = 1mA, f = 120Hz, I _{AC} = 0.1I _R			0.3		Ω
Wideband Noise	e _N	I _R = 10µA, 10Hz ≤ f ≤ 10kHz			20		µV _{RMS}
Reverse Breakdown Voltage	ΔV _R	t = 1000h			30		ppm

Note 1: All devices are 100% production tested at +25°C and are guaranteed by correlation for T_A = T_{MAX} to T_{MIN}, as specified.

Note 2: TC is measured by the "box" method, i.e. (V_{MAX} - V_{MIN}) / (T_{MAX} - T_{MIN})

Note 3: Guaranteed by design.

Typical Operating Characteristics

($I_R = 100\mu A$, $T_A = +25^\circ C$, unless otherwise noted.)

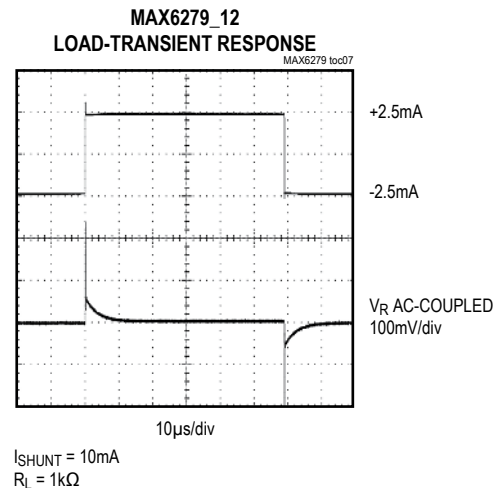
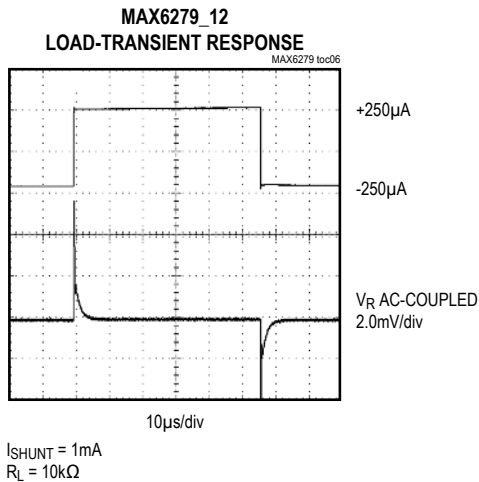
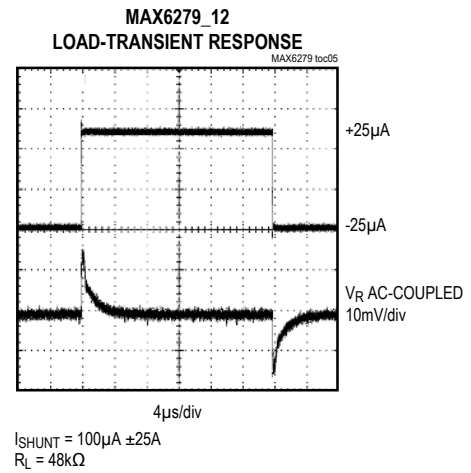
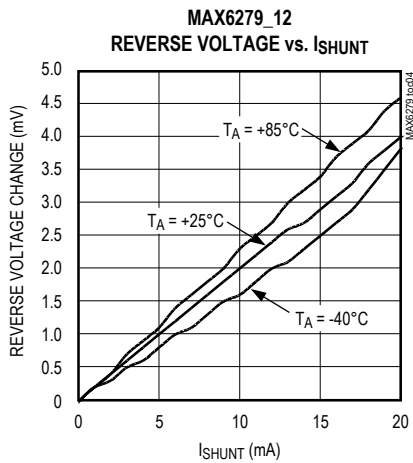
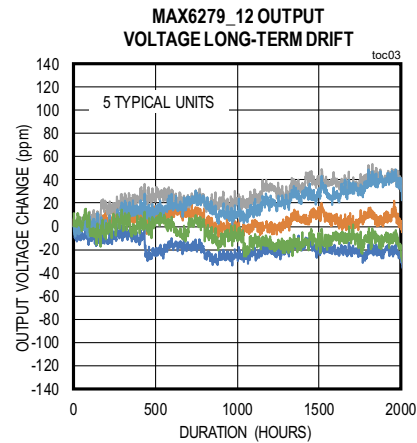
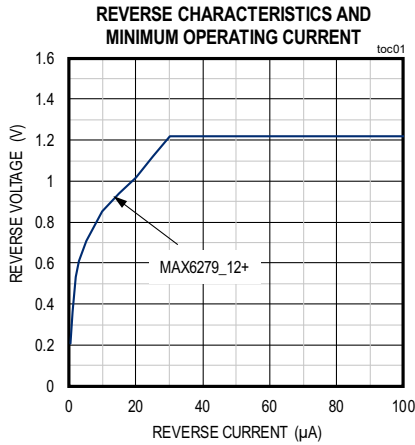

Typical Operating Characteristics (continued)

($I_R = 100\mu A$, $T_A = +25^\circ C$, unless otherwise noted.)

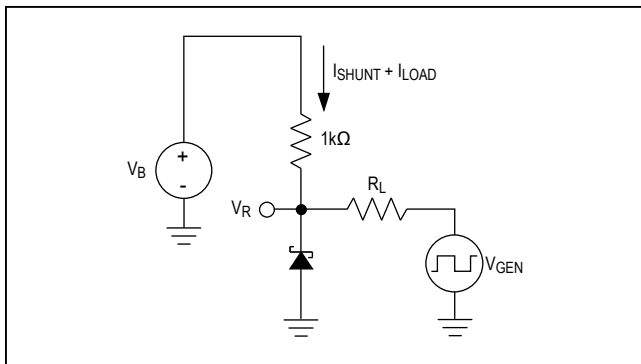
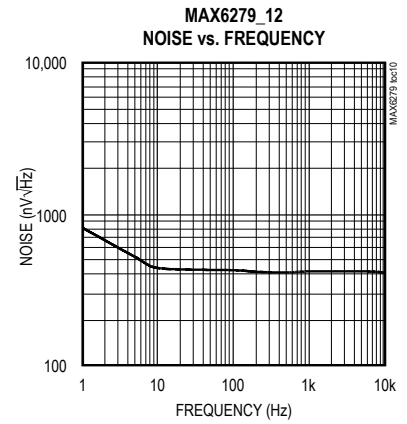
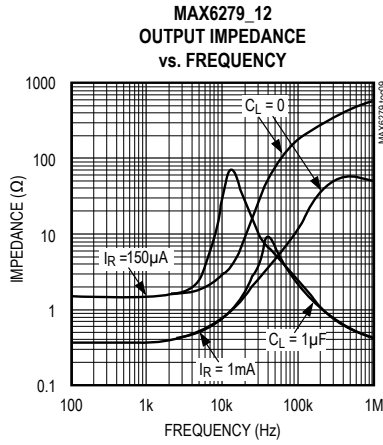
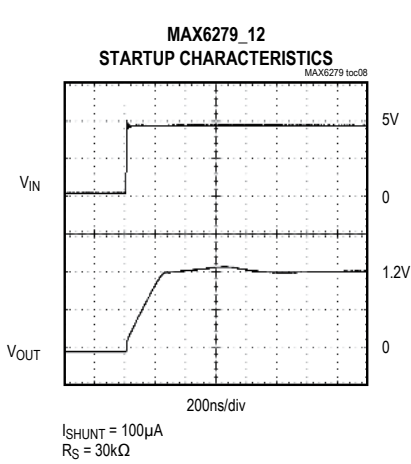

Figure 1. Load-Transient Circuit

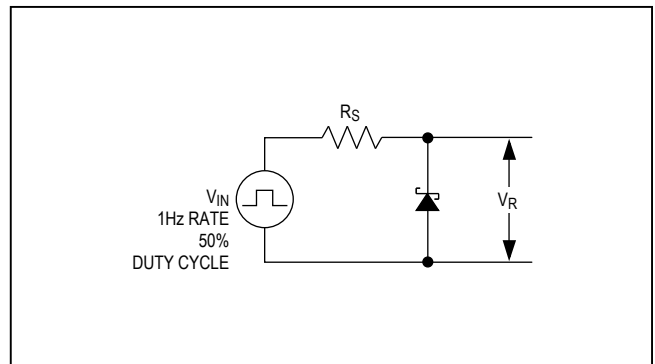
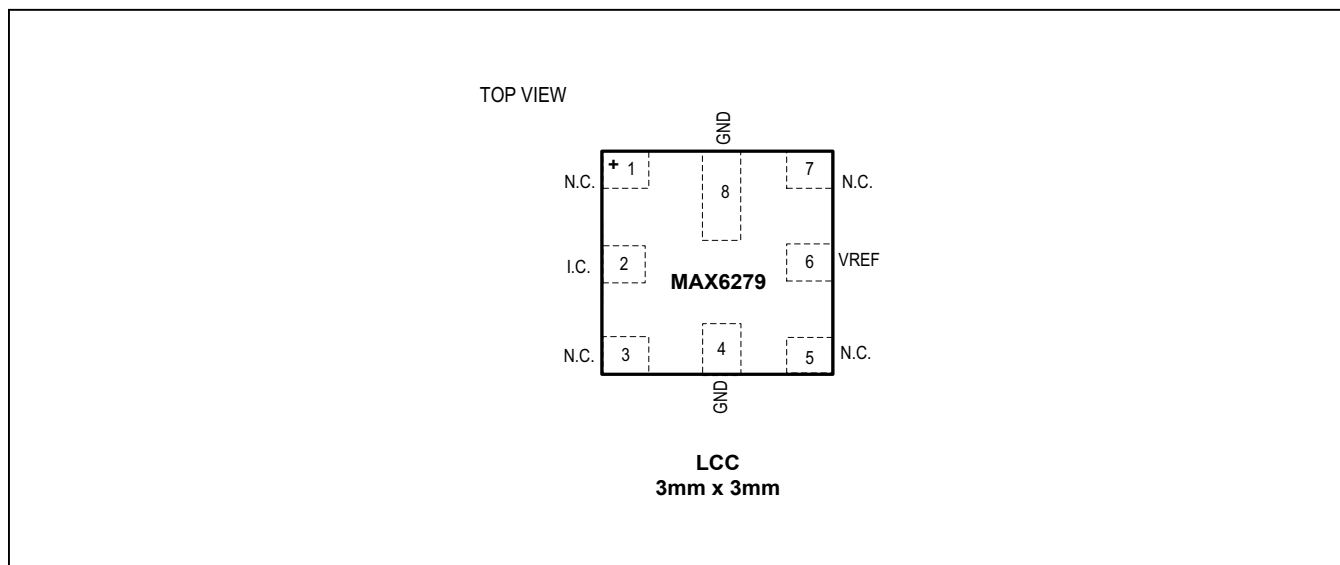

Figure 2. Startup Characteristics Test Circuit

Pin Configuration



Pin Description

PIN	NAME	FUNCTION
6	V _{REF}	Positive Terminal of the Shunt Reference
4, 8	GND	Negative Terminal of the Shunt Reference
2	I.C.	No Connection. Leave this pin unconnected or connect to GND.
1, 3, 5, 7	N.C.	No Connection. Not connected internally.

Detailed Description

The MAX6279 shunt reference uses the bandgap principle to produce a stable, accurate voltage. The device behaves similarly to an ideal zener diode; a fixed voltage is maintained across its output terminals when biased with 70µA to 12mA of reverse current. The MAX6279 behaves similarly to a silicon diode when biased with forward currents up to 10mA.

Figure 3 shows a typical operating circuit. The MAX6279 is ideal for providing a stable reference from a high-voltage power supply.

Applications Information

The MAX6279's internal pass transistor is used to maintain a constant output voltage (V_{SHUNT}) by sinking the necessary amount of current across a source resistor. The source resistance (R_S) is determined from the load current (I_{LOAD}) range, supply voltage (V_S) variations, V_{SHUNT} , and desired quiescent current.

Choose the value of R_S when V_S is at a minimum and I_{LOAD} is at a maximum. Maintain a minimum I_{SHUNT} of 70µA at all times. The R_S value should be large enough to keep I_{SHUNT} less than 12mA for proper regulation when V_S is maximum and I_{LOAD} is at a minimum. To prevent damage to the device, I_{SHUNT} should never exceed 20mA.

Therefore, the value of R_S is bounded by the following equation:

$$\frac{[V_{S(MIN)} - V_R]/[70\mu A + I_{LOAD(MAX)}]}{[V_{S(MAX)} - V_R]/[20mA + I_{LOAD(MIN)}]} > R_S >$$

Choosing a larger resistance minimizes the total power dissipation in the circuit by reducing the shunt current ($P_{D(TOTAL)} = V_S \times I_{SHUNT}$). Provide a safety margin to

incorporate the worst-case tolerance of the resistor used. Ensure that the resistor's power rating is adequate, using the following general power equation:

$$P_{DR} = I_{SHUNT} \times (V_{S(MAX)} - V_{SHUNT})$$

Output Capacitance

The MAX6279 does not require an external capacitor for operational stability and is stable for any output capacitance.

Temperature Performance

The MAX6279 typically exhibits an output voltage temperature coefficient within $\pm 4\text{ppm}/^\circ\text{C}$. The polarity of the temperature coefficient may be different from one device to another; some may have positive coefficients, and others may have negative coefficients.

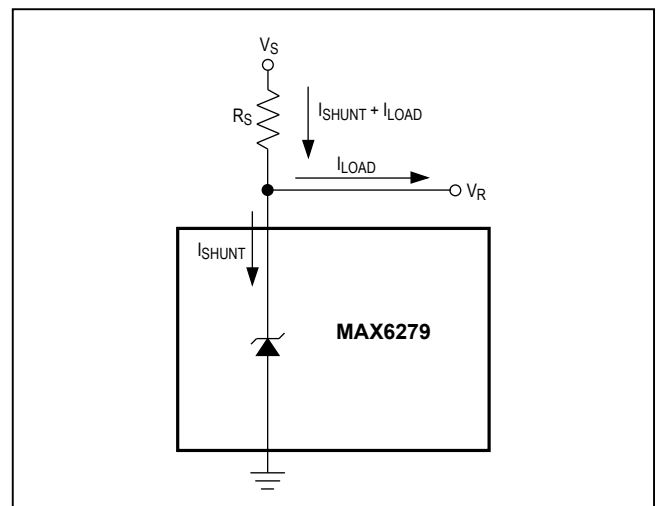

Figure 3. Typical Operating Circuit

The MAX6279 in Ceramic LCC Package

The MAX6279's ceramic LCC package is a hermetic ceramic package that gives substantially better performance than plastic, while at the same time is a small, surface-mount package. The MAX6279 die is packaged in this ceramic 8-LCC package that prevents the reference voltage from getting mechanical disturbances from humid environments, improving long-term drift and thermal hysteresis. The MAX6279's Ceramic LCC package shows excellent output long-term drift of 30ppm (Figure 4).

Thermal Hysteresis is also improved in the Ceramic LCC package. Hysteresis is the change in the output voltage is created by mechanical stress that applied to the device depending on whether it was previously at a higher or

lower temperature. Output voltage is always measured at $T_A = +25^{\circ}\text{C}$ before and after the device is cycled over its entire operating temperature range. The MAX6279 has a typical hysteresis value of 60ppm.

Even though the hermitically-sealed ceramic MAX6279 prevents the reference output from getting mechanical disturbances from humid environments, the PC board can be affected by humidity, and in turn causes mechanical stress to the MAX6279 being mounted on it. Proper board layout is critical for best stability and performance. Refer to the MAX6279 EV kit data sheet for recommended layout guidelines and power supply bypassing.

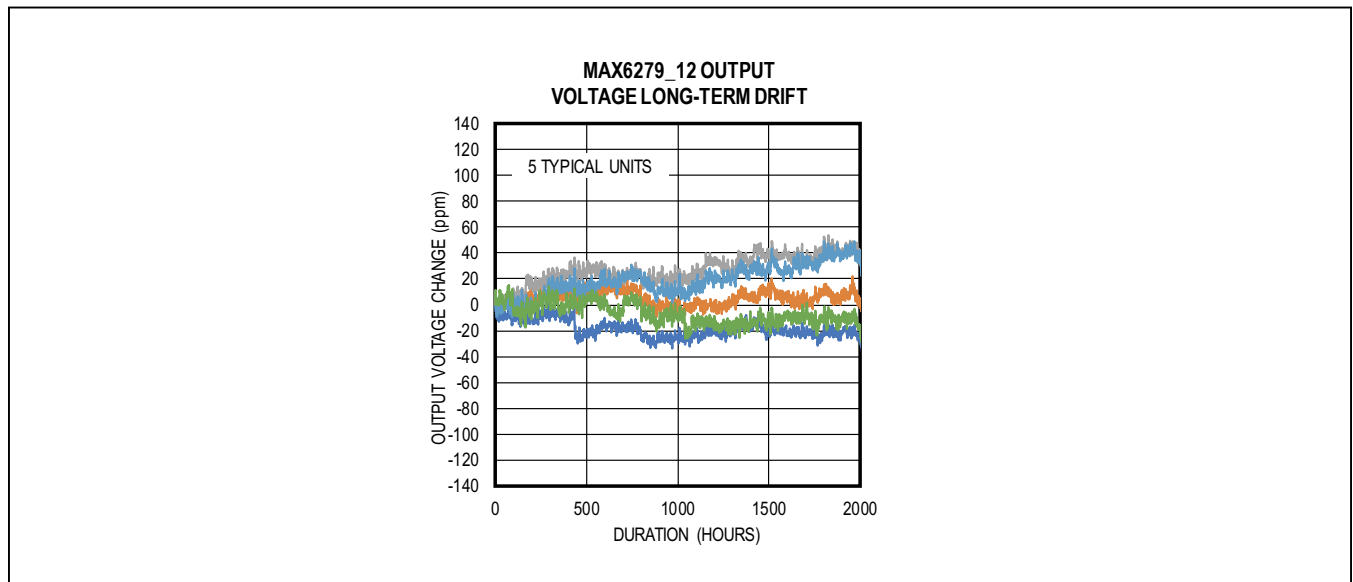

Figure 4. Output Voltage Long-Term Drift of the MAX6279 in Ceramic LCC Package

MAX6279

0.1%, 25ppm, Ceramic Shunt
Voltage Reference

Ordering Information

PART	OUTPUT VOLTAGE (V)	INITIAL ACCURACY (%)	TEMP RANGE	PIN-PACKAGE	TOP MARK
MAX6279ELA12+T	1.225	0.1	-40°C to +85°C	8 LCC	ADZA

Chip Information

TRANSISTOR COUNT: 70

PROCESS: BiCMOS

Package Information

For the latest package outline information and land patterns (footprints), go to www.maximintegrated.com/packages. Note that a "+", "#", or "-" in the package code indicates RoHS status only. Package drawings may show a different suffix character, but the drawing pertains to the package regardless of RoHS status.

PACKAGE TYPE	PACKAGE CODE	OUTLINE NO.	LAND PATTERN NO.
8 LCC	L8+1	21-100203	90-100085

Revision History

REVISION NUMBER	REVISION DATE	DESCRIPTION	PAGES CHANGED
0	10/18	Initial release	—
1	3/19	Updated <i>Pin Description</i>	5

For pricing, delivery, and ordering information, please visit Maxim Integrated's online storefront at <https://www.maximintegrated.com/en/storefront/storefront.html>.

Maxim Integrated cannot assume responsibility for use of any circuitry other than circuitry entirely embodied in a Maxim Integrated product. No circuit patent licenses are implied. Maxim Integrated reserves the right to change the circuitry and specifications without notice at any time. The parametric values (min and max limits) shown in the Electrical Characteristics table are guaranteed. Other parametric values quoted in this data sheet are provided for guidance.