

## DESCRIPTION

The MPM3690-30 is a dual 18A or single 36A output power module, which offers a complete power solution with excellent load and line regulation. The MPM3690-30 supports a 4V to 16V input voltage ( $V_{IN}$ ) range and a 0.6V to 3.3V output voltage ( $V_{OUT}$ ) range. The voltage of the MPM3690-30's two outputs can be set separately by a single resistor per output.

The MPM3690-30 offers two configurations: the MPM3690-30A has a dual 18A output, and the MPM3690-30B has a single 36A output. The MPM3690-30 is also pin-compatible with the MPM3690-20A/B (dual 13A or single 26A) and the MPM3690-50A/B (dual 25A or single 50A) power modules.

The MPM3690-30 adopts MPS's proprietary, multi-phase constant-on-time (MCOT) control, which provides ultra-fast transient response and minimizes the output capacitance.

The MPM3690-30 integrates monolithic DC/DC converter, power inductor, and other passive components, and is available in a BGA (16mmx16mmx5.18mm) package.

## FEATURES

- Pin-Compatible Dual 18A and Single 36A Output Power Modules
  - MPM3690-30A Dual 18A
  - MPM3690-30B Single 36A
- 4V to 16V Input Voltage Range
  - 3.2V to 16V Input Voltage Range with External 3.3V VCC Bias
- 0.6V to 3.3V Output Voltage Range
- Ultra-Fast Transient Enabled by Constant-On-Time (COT) Control
- Adjustable Switching Frequency
- Adjustable Soft-Start Time
- Over-Current and Over-Voltage Protection
- Differential Remote Sense for Both Output Channels
- Pin Compatible with the MPM3690-20 and MPM3695-50
- Available in a BGA (16mmx16mmx5.18mm) Package

## APPLICATIONS

- Telecom and Networking Equipment
- Industrial Equipment
- FPGA and ASIC Power Systems

All MPS parts are lead-free, halogen-free, and adhere to the RoHS directive. For MPS green status, please visit the MPS website under Quality Assurance. "MPS", the MPS logo, and "Simple, Easy Solutions" are trademarks of Monolithic Power Systems, Inc. or its subsidiaries.

## TYPICAL APPLICATION

### Interleaved Operation at 1.2V, 36A

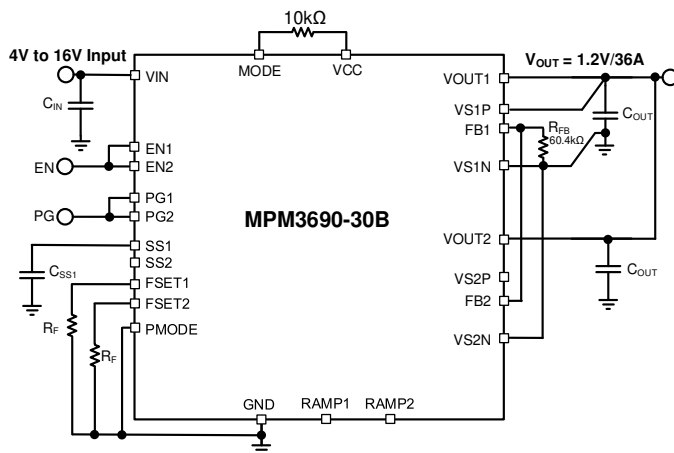

### Efficiency vs. Load Current

$V_{IN} = 12V$ , with external 3.3V VCC

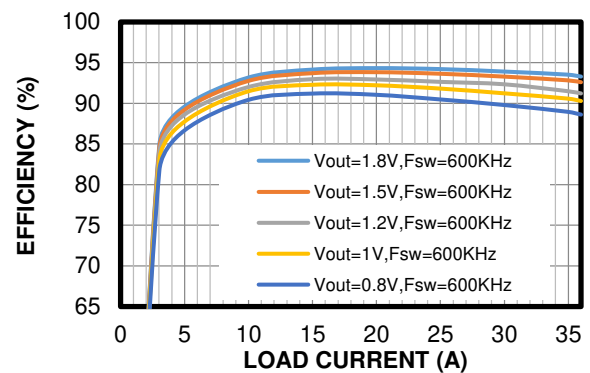

### ORDERING INFORMATION

Part Number*	Configuration	Package	Top Marking	MSL Rating
MPM3690GBF-30A	Dual 18A output	BGA	See Below	3
MPM3690GBF-30B	Single 36A output	(16mmx16mmx5.18mm)		

\* For Tray, add suffix -T (e.g. MPM3690GBF-30A-T).

### TOP MARKING (MPM3690GBF-30A)

MPS YYWW  
M3690-30A  
LLLLLLLLLL  
M

MPS: MPS prefix  
YY: Year code  
WW: Week code  
M3690-30A: Part number  
LLLLLLLLLL: Lot number  
M: Module

### TOP MARKING (MPM3690GBF-30B)

MPS YYWW  
M3690-30B  
LLLLLLLLLL  
M

MPS: MPS prefix  
YY: Year code  
WW: Week code  
M3690-30B: Part number  
LLLLLLLLLL: Lot number  
M: Module

**PIN-COMPATIBLE PARTS**

Part Number	Output	Description
MPM3690GBF-20A	Dual 13A	4V to 16V input, 0.6V to 3.3V output, BGA (16mmx16mmx5.18mm) package
MPM3690GBF-20B	Single 26A	4V to 16V input, 0.6V to 3.3V output, BGA (16mmx16mmx5.18mm) package
MPM3690GBF-30A	Dual 18A	4V to 16V input, 0.6V to 3.3V output, BGA (16mmx16mmx5.18mm) package
MPM3690GBF-30B	Single 36A	4V to 16V input, 0.6V to 3.3V output, BGA (16mmx16mmx5.18mm) package
MPM3690GBF-50A	Dual 25A	4V to 16V input, 0.6V to 1.8V output, BGA (16mmx16mmx5.18mm) package
MPM3690GBF-50B	Single 50A	4V to 16V input, 0.6V to 1.8V output, BGA (16mmx16mmx5.18mm) package

Order directly from [MonolithicPower.com](http://MonolithicPower.com) or our distributors.

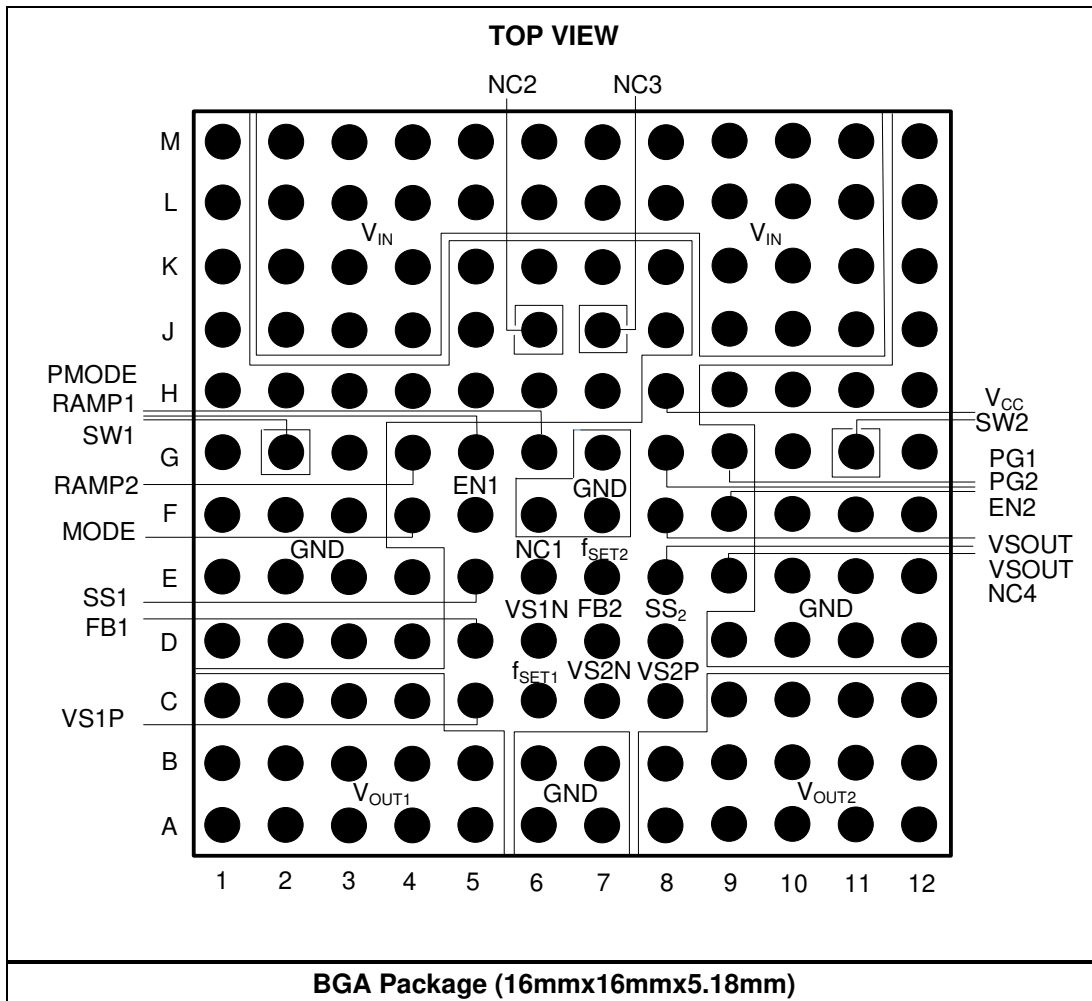
**PACKAGE REFERENCE**

## PIN FUNCTIONS

Pin #	Name	Description
A1, A2, A3, A4, A5, B1, B2, B3, B4, B5, C1, C2, C3, C4	VOUT1	<b>Power output 1.</b> Power output pins for channel 1.
A6, A7, B6, B7, D1, D2, D3, D4, D9, D10, D11, D12, E1, E2, E3, E4, E10, E11, E12, F1, F2, F3, F6, F7, F10, F11, F12, G1, G3, G7, G10, G12, H1, H2, H3, H4, H5, H6, H7, H9, H10, H11, H12, J1, J5, J8, J12, K1, K5, K6, K7, K8, K12, L1, L12, M1, M12	GND	<b>Power ground.</b> GND is the ground of the regulated output voltage ( $V_{OUT}$ ).
A8, A9, A10, A11, A12, B8, B9, B10, B11, B12, C9, C10, C11, C12	VOUT2	<b>Power output 2.</b> Power output pins for channel 2.
C5, C8	VS1P, VS2P	<b>Positive input of the remote-sense amplifier.</b> Connect these pins to the $V_{OUT}$ remote sense point.
D6, C7	VS1N, VS2N	<b>Negative input of the remote-sense amplifier.</b> Connect these pins to the output GND remote sense point to enable remote sense. Connect to GND to disable remote sense functionality.
C6, E7	FSET1, FSET2	<b>Frequency set.</b> Connect a resistor between these pins and AGND to configure the switching frequency ( $f_{sw}$ ) between 400kHz to 1MHz. For the MPM3690-30B, the of FSET1 and FSET2 resistors must be the same.
D5, D7	FB1, FB2	<b>Feedback voltage.</b> Connect a resistor to these pins between VS1N and VS2N to program $V_{OUT}$ . This pin is connected to VS1P and VS2P with a 60.4k $\Omega$ resistor.
E5, D8	SS1, SS2	<b>Soft-start time set.</b> Connect a ceramic capacitor to set the soft-start time ( $t_{ss}$ ).
G5, G4	RAMP1, RAMP2	<b>Ramp selection pin.</b> Float these pins to set the internal compensation ramp to high; pull these pins pin low to set the internal compensation ramp to low.
E8, F8	VSOUT	<b>Not connected (internally floated).</b> Float these pins.
F4	MODE	<b>Operation mode set.</b> Pull-up to VCC for forced continuous conduction mode (FCCM).
F5, F9	EN1, EN2	<b>Enable pins.</b> Drive these pins high to turn the output on; drive them low to turn the output off. Do not float these pins.
G2, G11	SW1, SW2	<b>Switching nodes.</b> Float these pins.
G6	PMODE	<b>Protection mode selection.</b> Connect to GND for latch-off mode, pull-up to VCC for auto-retry (hiccup) mode.
G9, G8	PG1, PG2	<b>Power good outputs.</b> The output of these is an open drain. Pull these pins high with a pull-up resistor.
H8	VCC	<b>Output of the internal power supply.</b> Float this pin or connect it to an external 3.3V power supply to improve efficiency.
E6, J6, J7, E9	NC1, NC2, NC3, NC4	<b>Not connected (internally floated).</b> Float these pins.
M2, M3, M4, M5, M6, M7, M8, M9, M10, M11, L2, L3, L4, L5, L6, L7, L8, L9, L10, L11, J2, J3, J4, J9, J10, J11, K2, K3, K4, K9, K10, K11	VIN	<b>Supply voltage.</b> These pins provide power to the module. Connect decoupling capacitors between the VIN and GND pins.

**PIN MAP**

Pin #	Function	Pin #	Function	Pin #	Function	Pin #	Function	Pin #	Function	Pin #	Function
A1	V <sub>OUT1</sub>	B1	V <sub>OUT1</sub>	C1	V <sub>OUT1</sub>	D1	GND	E1	GND	F1	GND
A2	V <sub>OUT1</sub>	B2	V <sub>OUT1</sub>	C2	V <sub>OUT1</sub>	D2	GND	E2	GND	F2	GND
A3	V <sub>OUT1</sub>	B3	V <sub>OUT1</sub>	C3	V <sub>OUT1</sub>	D3	GND	E3	GND	F3	GND
A4	V <sub>OUT1</sub>	B4	V <sub>OUT1</sub>	C4	V <sub>OUT1</sub>	D4	GND	E4	GND	F4	MODE
A5	V <sub>OUT1</sub>	B5	V <sub>OUT1</sub>	C5	VS1P	D5	FB1	E5	SS1	F5	EN1
A6	GND	B6	GND	C6	f <sub>SET1</sub>	D6	VS1N	E6	NC1	F6	GND
A6	GND	B6	GND	C6	f <sub>SET1</sub>	D6	VS1N	E6	NC1	F6	GND
A7	GND	B7	GND	C7	VS2N	D7	FB2	E7	f <sub>SET2</sub>	F7	GND
A8	V <sub>OUT2</sub>	B8	V <sub>OUT2</sub>	C8	VS2P	D8	SS2	E8	VSOUT	F8	VSOUT
A9	V <sub>OUT2</sub>	B9	V <sub>OUT2</sub>	C9	V <sub>OUT2</sub>	D9	GND	E9	NC4	F9	EN2
A10	V <sub>OUT2</sub>	B10	V <sub>OUT2</sub>	C10	V <sub>OUT2</sub>	D10	GND	E10	GND	F10	GND
A11	V <sub>OUT2</sub>	B11	V <sub>OUT2</sub>	C11	V <sub>OUT2</sub>	D11	GND	E11	GND	F11	GND
A12	V <sub>OUT2</sub>	B12	V <sub>OUT2</sub>	C12	V <sub>OUT2</sub>	D12	GND	E12	GND	F12	GND

Pin #	Function	Pin #	Function	Pin #	Function	Pin #	Function	Pin #	Function	Pin #	Function
G1	GND	H1	GND	J1	GND	K1	GND	L1	GND	M1	GND
G2	SW1	H2	GND	J2	V <sub>IN</sub>	K2	V <sub>IN</sub>	L2	V <sub>IN</sub>	M2	V <sub>IN</sub>
G3	GND	H3	GND	J3	V <sub>IN</sub>	K3	V <sub>IN</sub>	L3	V <sub>IN</sub>	M3	V <sub>IN</sub>
G4	RAMP2	H4	GND	J4	V <sub>IN</sub>	K4	V <sub>IN</sub>	L4	V <sub>IN</sub>	M4	V <sub>IN</sub>
G5	RAMP1	H5	GND	J5	GND	K5	GND	L5	V <sub>IN</sub>	M5	V <sub>IN</sub>
G6	PMODE	H6	GND	J6	NC2	K6	GND	L6	V <sub>IN</sub>	M6	V <sub>IN</sub>
G7	GND	H7	GND	J7	NC3	K7	GND	L7	V <sub>IN</sub>	M7	V <sub>IN</sub>
G8	PG2	H8	V <sub>CC</sub>	J8	GND	K8	GND	L8	V <sub>IN</sub>	M8	V <sub>IN</sub>
G9	PG1	H9	GND	J9	V <sub>IN</sub>	K9	V <sub>IN</sub>	L9	V <sub>IN</sub>	M9	V <sub>IN</sub>
G10	GND	H10	GND	J10	V <sub>IN</sub>	K10	V <sub>IN</sub>	L10	V <sub>IN</sub>	M10	V <sub>IN</sub>
G11	SW2	H11	GND	J11	V <sub>IN</sub>	K11	V <sub>IN</sub>	L11	V <sub>IN</sub>	M11	V <sub>IN</sub>
G12	GND	H12	GND	J12	GND	K12	GND	L12	GND	M12	GND

**ABSOLUTE MAXIMUM RATINGS** <sup>(1)</sup>

Supply voltage ( $V_{IN}$ ) .....	18V
$V_{SW1,2}$ (DC) .....	-0.3V to +18.3V
$V_{CC}$ .....	4.5V
$V_{CC}$ (1s) <sup>(3)</sup> .....	6V
All other pins .....	-0.3V to +4.3V
All other pins (1s) <sup>(3)</sup> .....	6V
Continuous power dissipation ( $T_A = 25^\circ\text{C}$ ) <sup>(2)</sup> .....	18.59W
Junction temperature .....	170°C
Lead temperature .....	260°C
Storage temperature .....	-65°C to +170°C

**Recommended Operating Conditions** <sup>(3)</sup>

Supply voltage ( $V_{IN}$ ) .....	4V to 16V
Output voltage ( $V_{OUT}$ ) .....	0.6V to 3.3V
Operating junction temp ( $T_J$ ) ....	-40°C to +125°C

<b>Thermal Resistance</b> <sup>(4)</sup>	$\theta_{JA}$	$\theta_{JC}$
EVM3690-30B-BF-00A .....	7.8	4.1 .. °C/W

**Notes:**

- 1) Exceeding these ratings may damage the device.
- 2) The maximum allowable power dissipation is a function of the maximum junction temperature  $T_J$  (MAX), the junction-to-ambient thermal resistance  $\theta_{JA}$ , and the ambient temperature  $T_A$ . The maximum allowable continuous power dissipation at any ambient temperature is calculated by  $P_D$  (MAX) =  $(T_J$  (MAX) -  $T_A$ ) /  $\theta_{JA}$ . Exceeding the maximum allowable power dissipation produces an excessive die temperature, causing the regulator to go into thermal shutdown. Internal thermal shutdown circuitry protects the device from permanent damage.
- 3) The device is not guaranteed to function outside of its operating conditions.
- 4) Measured on the EVM3690-30B-BF-00A, 10cmx10cm, 4-layer PCB.

## ELECTRICAL CHARACTERISTICS

$V_{IN} = 12V$ ,  $T_J = -40^{\circ}C$  to  $125^{\circ}C$ , unless otherwise noted.

Parameters	Symbol	Condition	Min	Typ	Max	Units
<b><math>V_{IN}</math> Supply Current</b>						
Quiescent supply current	$I_{IN}$	$EN = 0V$ , $FB = 0.65V$ , $R_{FREQ} = 30k$ to GND		1.5	2	mA
<b>Output Current Limit</b>						
Output current limit (inductor valley)	$I_{LIM\_VALLEY}$	Individual phase current limit, $f_{SW} = 800kHz$ , $V_{OUT} = 1.2V$		24		A
Low-side (LS) negative current limit	$I_{LIM\_NEG}$	Individual phase current limit		-13		A
<b>Frequency and Timer</b>						
Switching frequency	$f_{sw}$	$R_{FREQ} = 30k\Omega$		800		kHz
Minimum on time <sup>(5)</sup>	$t_{ON\_MIN}$	$f_{SW} = 800kHz$ , $V_{OUT} = 0.6V$		50		ns
Minimum off time <sup>(5)</sup>	$t_{OFF\_MIN}$			220		ns
<b>Output Over-Voltage Protection (OVP) and Under-Voltage Protection (UVP)</b>						
OVP threshold	$V_{OVP}$		116%	120%	124%	$V_{REF}$
UVP threshold	$V_{UVP}$		70%	74%	79%	$V_{REF}$
<b>EN</b>						
Input high voltage	$V_{IH\_EN}$		2.15			V
Input low voltage	$V_{IL\_EN}$				1.20	V
<b>Feedback Voltage</b>						
Feedback accuracy			594	600	606	mV
<b>Soft Start</b>						
Soft-start current	$I_{SS}$		15	20	25	$\mu A$
<b>Error Amplifier (EA)</b>						
Feedback current	$I_{FB}$	$V_{FB} = 0.65V$		50	100	nA
<b>Soft Shutdown</b>						
Soft shutdown discharge FET	$R_{ON\_DISCH}$	$T_J = 25^{\circ}C$		60	120	$\Omega$
<b>Under-Voltage Lockout (UVLO)</b>						
VCC UVLO rising threshold	$V_{CCVTH\_RISING}$		2.6	2.75	2.9	V
VCC UVLO falling threshold	$V_{CCVTH\_FALLING}$		2.3	2.45	2.6	V
VCC output voltage	$V_{CC}$		3.1	3.25	3.4	V
<b>Power Good (PG)</b>						
PG high threshold	$PG_{VTH\_HI\_RISE}$	FB from low to high	88.5%	92.5%	96.5%	$V_{REF}$
PG low threshold	$PG_{VTH\_LO\_RISE}$	FB from low to high	116%	120%	124%	$V_{REF}$
	$PG_{VTH\_LO\_FALL}$	FB from high to low	70%	74%	78%	$V_{REF}$
PG sink current capability	$V_{PG}$	$I_{PG} = 10mA$			0.3	V
PG leakage current	$I_{PG\_LEAK}$	$V_{PG} = 3V$ , $T_J = 25^{\circ}C$		1.5	2.50	$\mu A$

**ELECTRICAL CHARACTERISTICS (continued)**
 $V_{IN} = 12V$ ,  $T_J = -40^{\circ}C$  to  $+125^{\circ}C$ , unless otherwise noted.

Parameters	Symbol	Condition	Min	Typ	Max	Units
PG low-level output voltage	$V_{OL_{100}}$	$V_{IN} = 0V$ , pull PG up to 3.3V through a 100k $\Omega$ resistor, $T_J = 25^{\circ}C$		600	720	mV
	$V_{OL_{10}}$	$V_{IN} = 0V$ , pull PG up to 3.3V through a 10k $\Omega$ resistor, $T_J = 25^{\circ}C$		700	820	
<b>Thermal Protections</b>						
Thermal shutdown threshold <sup>(5)</sup>				160		$^{\circ}C$
Thermal hysteresis threshold <sup>(5)</sup>				30		$^{\circ}C$

**Note:**

5) Guaranteed by sample characterization. Not tested in production. The parameter is tested during parameters characterization.



## TYPICAL PERFORMANCE CHARACTERISTICS

MPM3690-30A,  $V_{IN} = 12V$ ,  $V_{OUT1} = V_{OUT2} = 1.2V$ ,  $C_{OUT1} = C_{OUT2} = 690\mu F$ ,  $f_{SW1} = f_{SW2} = 500kHz$ , FCCM,  $T_A = 25^\circ C$ , unless otherwise noted.

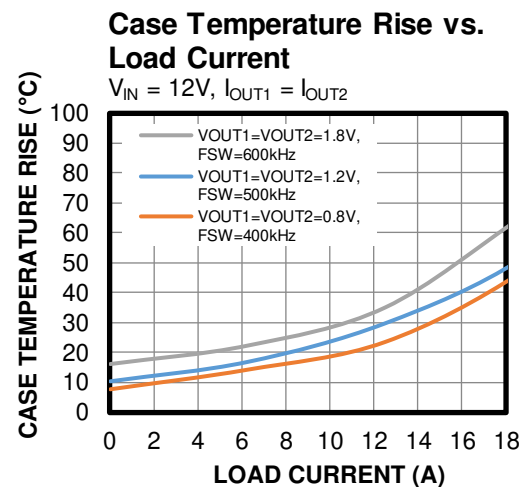
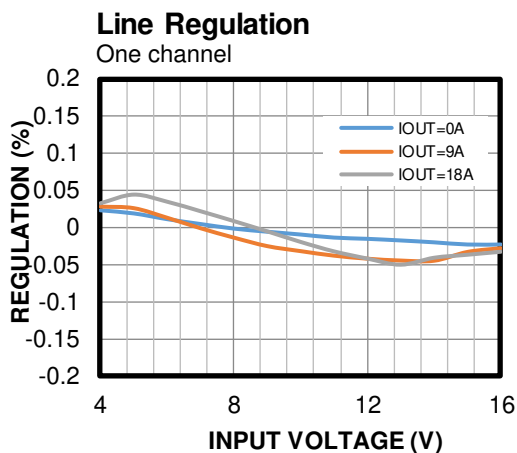
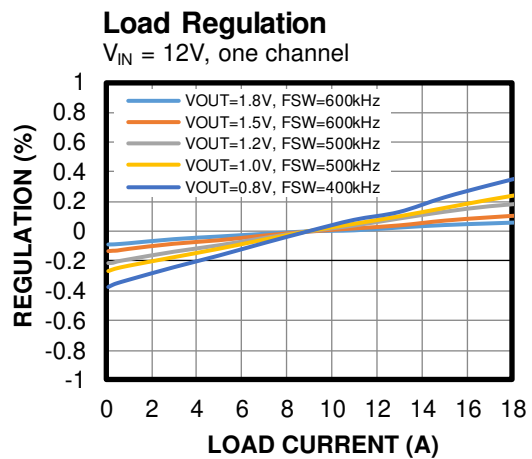
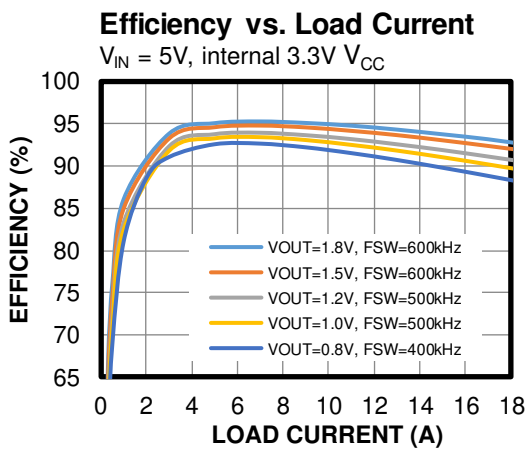
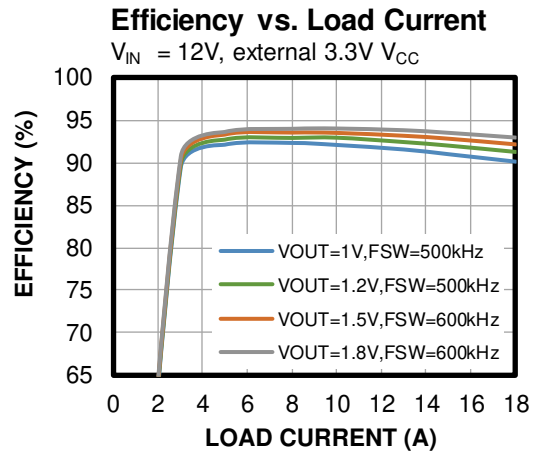
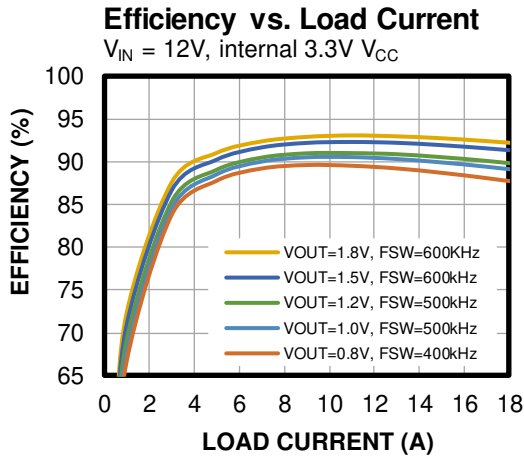

## TYPICAL PERFORMANCE CHARACTERISTICS *(continued)*

MPM3690-30A,  $V_{IN} = 12V$ ,  $V_{OUT1} = V_{OUT2} = 1.2V$ ,  $C_{OUT1} = C_{OUT2} = 690\mu F$ ,  $f_{SW1} = f_{SW2} = 500kHz$ , FCCM,  $T_A = 25^\circ C$ , unless otherwise noted.

### Ripple

$I_{OUT1} = I_{OUT2} = 0A$

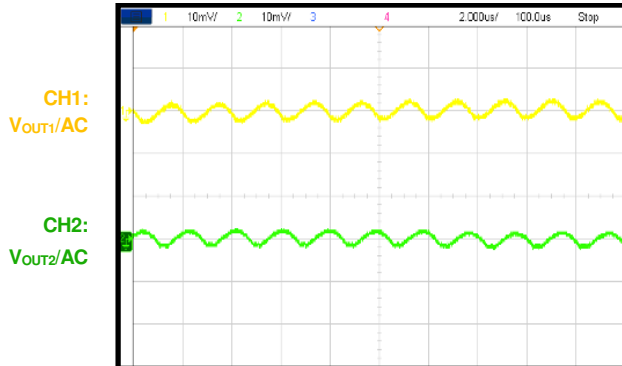

### Ripple

$I_{OUT1} = I_{OUT2} = 18A$

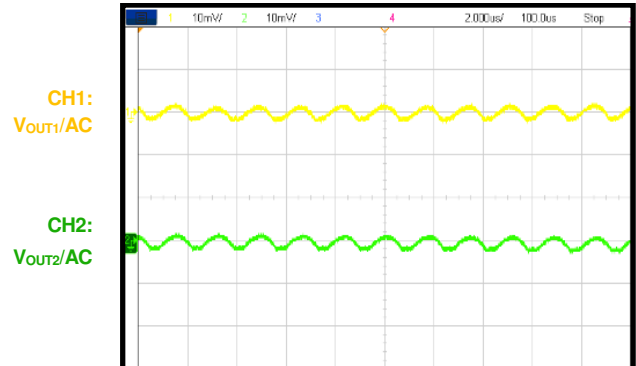

### Start-Up through VIN

$I_{OUT1} = I_{OUT2} = 0A$

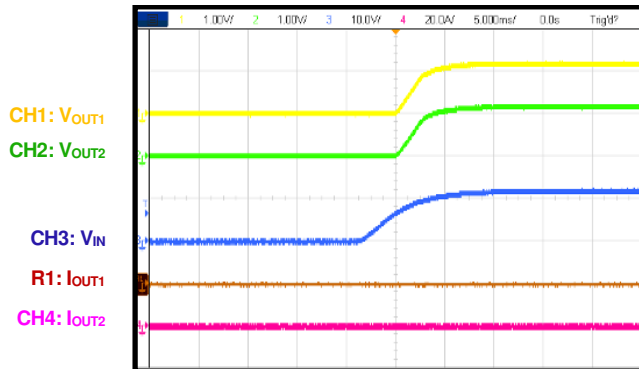

### Start-Up through VIN

$I_{OUT1} = I_{OUT2} = 18A$

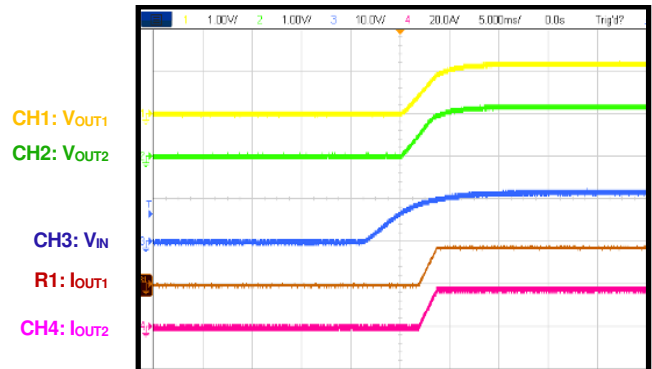

### Shutdown through VIN

$I_{OUT1} = I_{OUT2} = 0A$

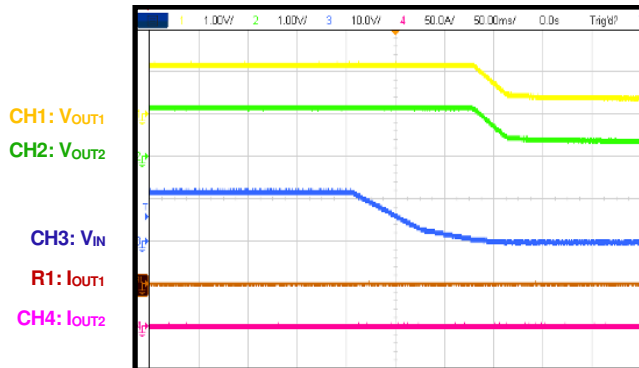

### Shutdown through VIN

$I_{OUT1} = I_{OUT2} = 18A$

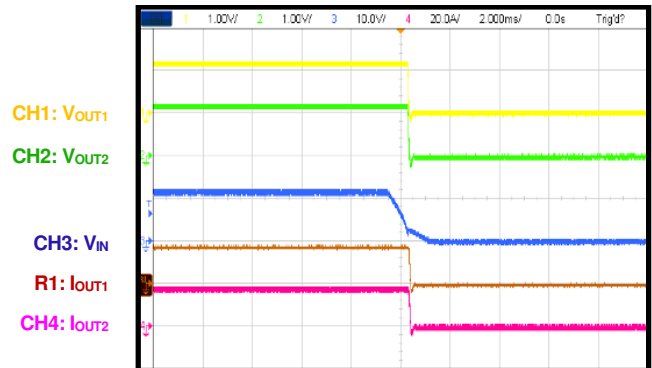

## TYPICAL PERFORMANCE CHARACTERISTICS *(continued)*

MPM3690-30A,  $V_{IN} = 12V$ ,  $V_{OUT1} = V_{OUT2} = 1.2V$ ,  $C_{OUT1} = C_{OUT2} = 690\mu F$ ,  $f_{SW1} = f_{SW2} = 500kHz$ , FCCM,  $T_A = 25^\circ C$ , unless otherwise noted.

### Start-Up through EN

$I_{OUT1} = 0A$

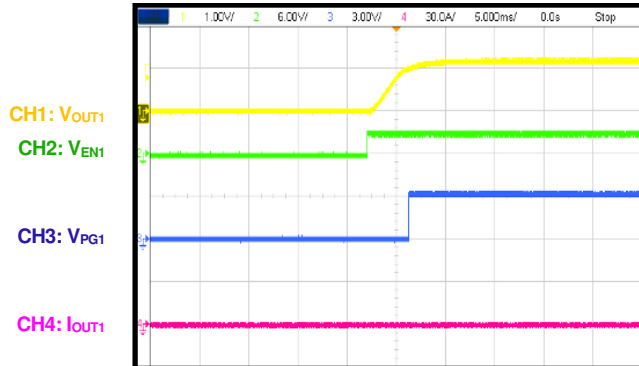

### Start-Up through EN

$I_{OUT1} = 18A$

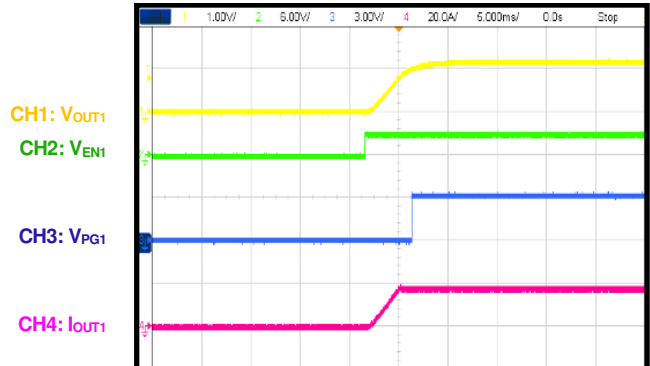

### Shutdown through EN

$I_{OUT1} = 0A$

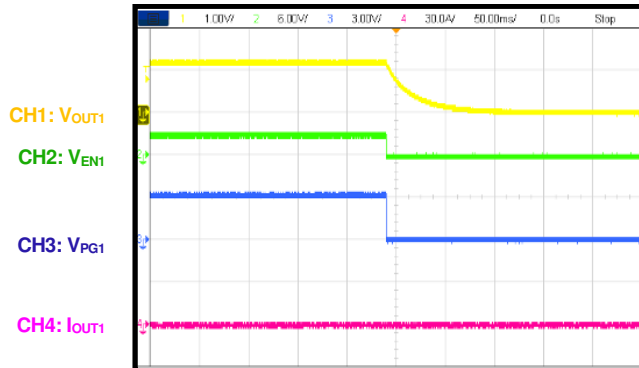

### Shutdown through EN

$I_{OUT1} = 18A$

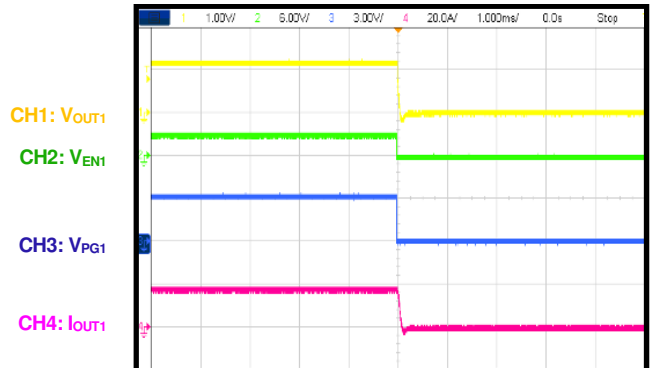

### Load Transient

4.5A load step,  $10A/\mu s$ ,  $C_{OUT} = 10 \times 47\mu F$ , ceramic +  $220\mu F$  POSCAP,  $C_{FF} = 33nF$ , high ramp

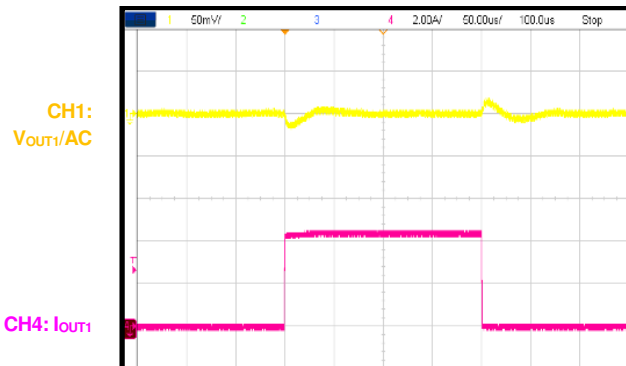

### Load Transient

9A load step,  $10A/\mu s$ ,  $C_{OUT} = 10 \times 47\mu F$ , ceramic +  $220\mu F$  POSCAP,  $C_{FF} = 33nF$ , high ramp

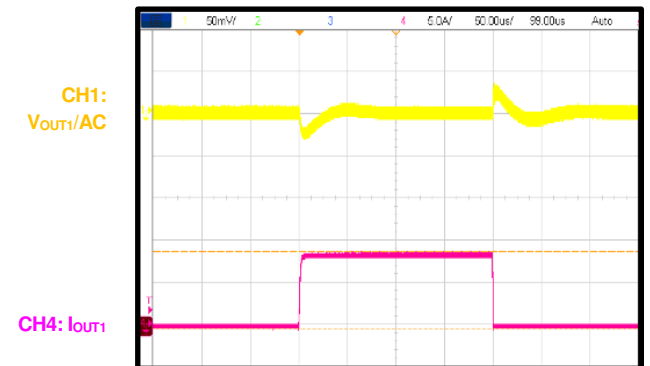

## TYPICAL PERFORMANCE CHARACTERISTICS *(continued)*

MPM3690-30B,  $V_{IN} = 12V$ ,  $V_{OUT} = 1.2V$ ,  $C_{OUT} = 1380\mu F$ ,  $f_{SW} = 500kHz$ , FCCM,  $T_A = 25^\circ C$ , unless otherwise noted.

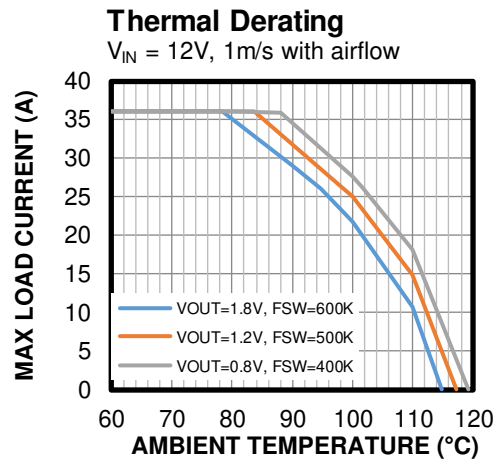
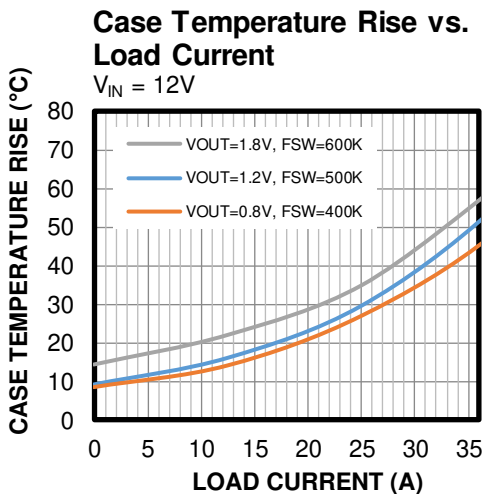
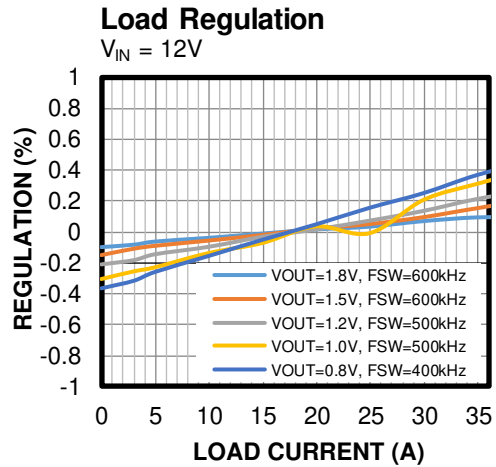
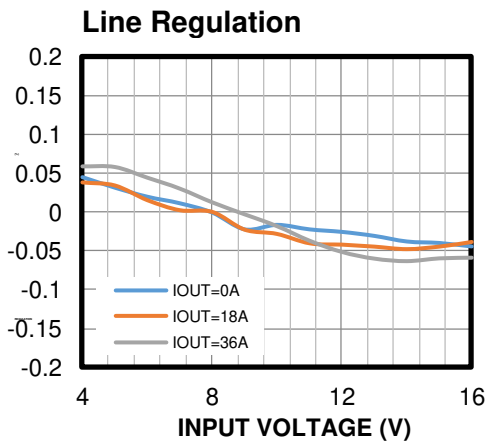
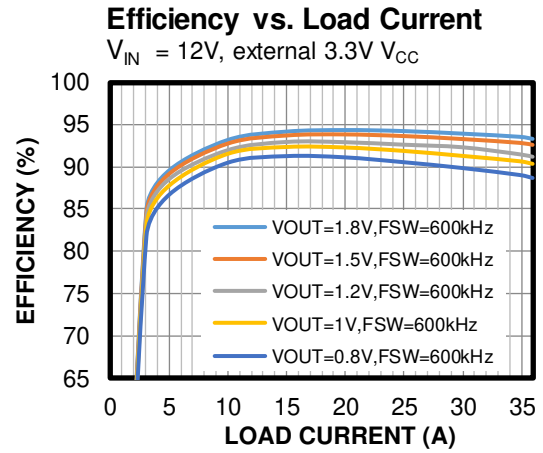
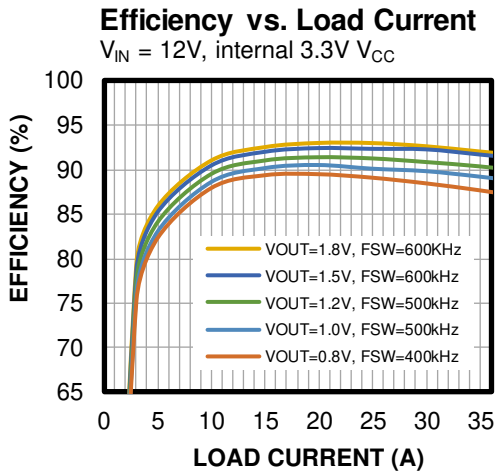

**TYPICAL PERFORMANCE CHARACTERISTICS (continued)**

MPM3690-30B,  $V_{IN} = 12V$ ,  $V_{OUT} = 1.2V$ ,  $C_{OUT} = 1380\mu F$ ,  $f_{SW} = 500kHz$ , FCCM,  $T_A = 25^\circ C$ , unless otherwise noted.

**Ripple**

$I_{OUT} = 0A$ ,  $C_{OUT} = 20 \times 47\mu F$ ,  
ceramic + 2 x 220 $\mu F$  POSCAP

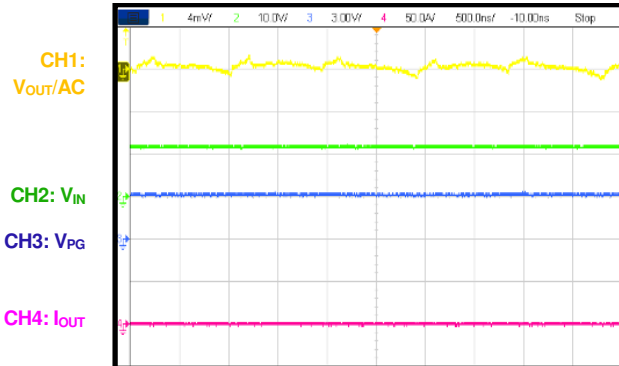

**Ripple**

$I_{OUT} = 36A$ ,  $C_{OUT} = 20 \times 47\mu F$ ,  
ceramic + 2 x 220 $\mu F$  POSCAP

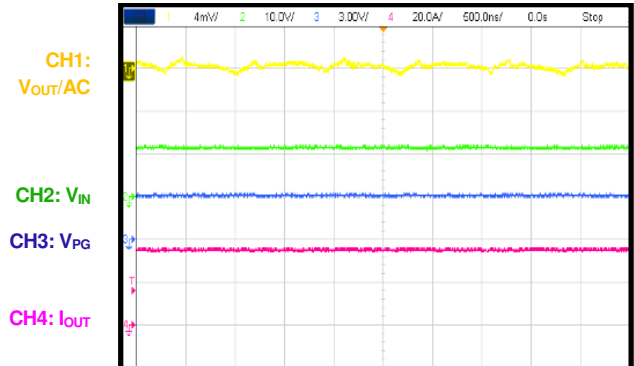

**Start-Up through VIN**

$I_{OUT} = 0A$

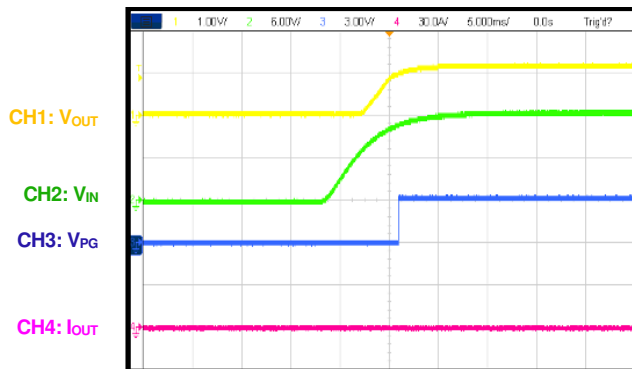

**Start-Up through VIN**

$I_{OUT} = 36A$

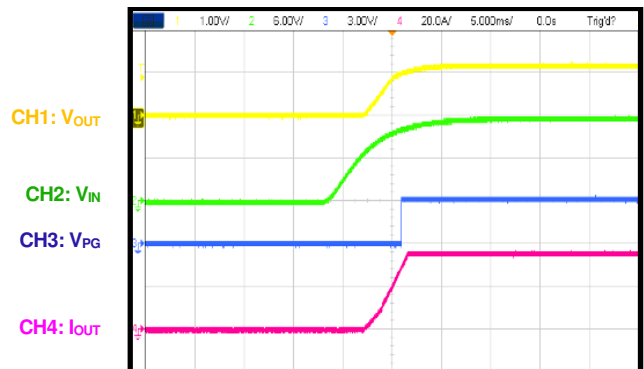

**Shutdown through VIN**

$I_{OUT} = 0A$

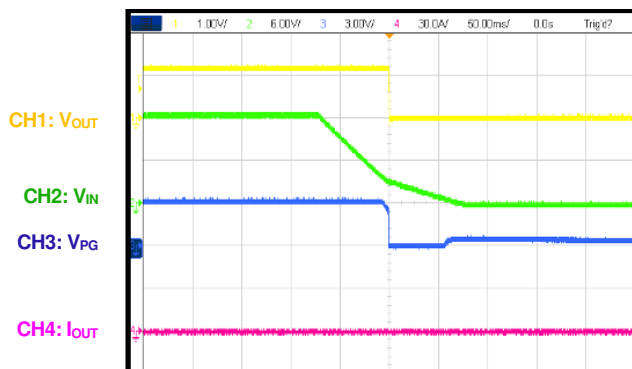

**Shutdown through VIN**

$I_{OUT} = 36A$

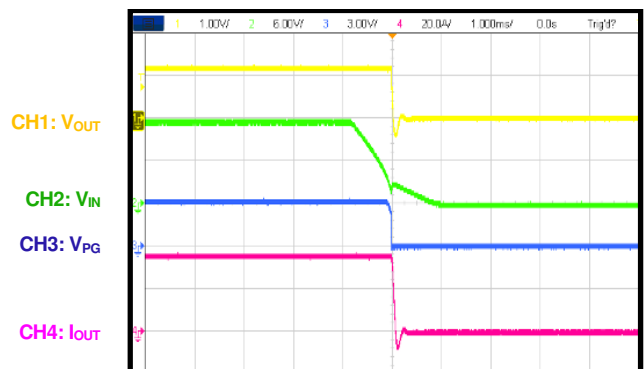

**TYPICAL PERFORMANCE CHARACTERISTICS (continued)**

MPM3690-30B,  $V_{IN} = 12V$ ,  $V_{OUT} = 1.2V$ ,  $C_{OUT} = 1380\mu F$ ,  $f_{SW} = 500kHz$ , FCCM,  $T_A = 25^\circ C$ , unless otherwise noted.

**Start-Up through EN**  
 $I_{OUT} = 0A$

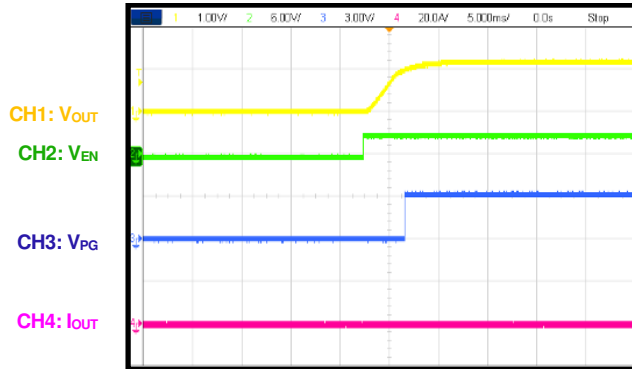

**Start-Up through EN**  
 $I_{OUT} = 36A$

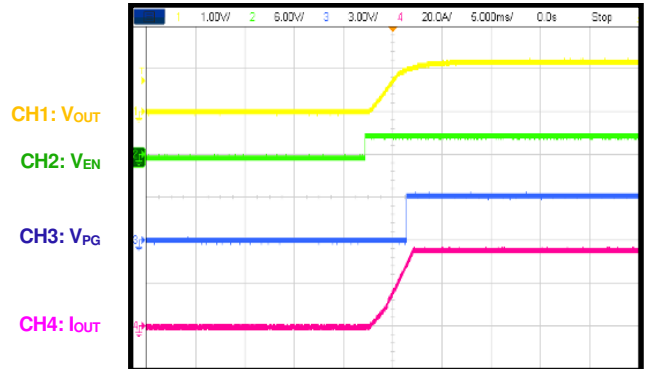

**Shutdown through EN**  
 $I_{OUT} = 0A$

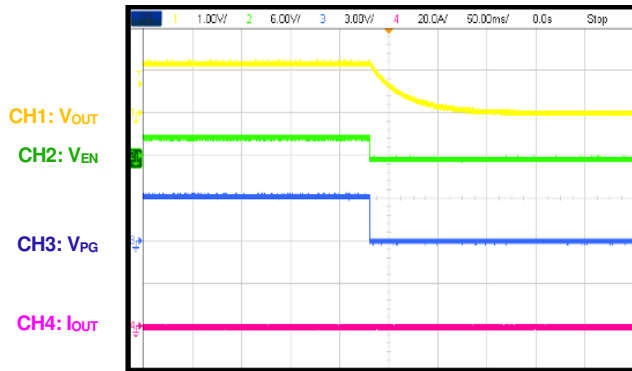

**Shutdown through EN**  
 $I_{OUT} = 36A$

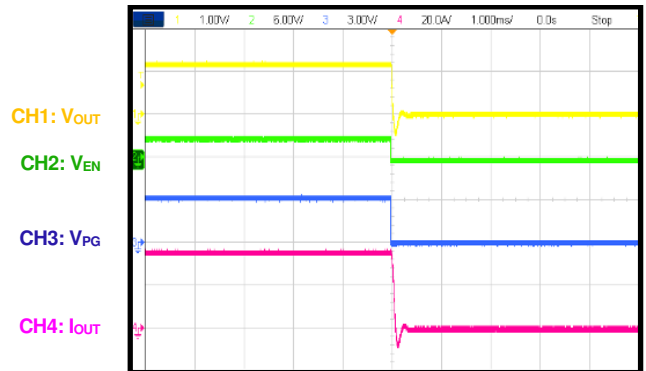

**Load Transient**

9A load step,  $10A/\mu s$ ,  $C_{OUT} = 20 \times 47\mu F$ , ceramic +  $2 \times 220\mu F$  POSCAP,  $C_{FF} = 33nF$ , high ramp

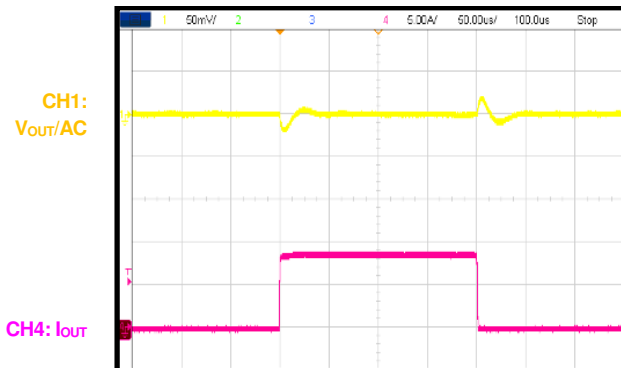

**Load Transient**

18A load step,  $10A/\mu s$ ,  $C_{OUT} = 20 \times 47\mu F$ , ceramic +  $2 \times 220\mu F$  POSCAP,  $C_{FF} = 33nF$ , high ramp

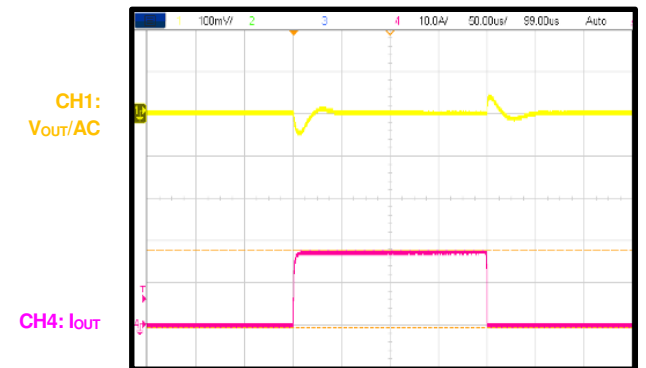

## FUNCTIONAL BLOCK DIAGRAM

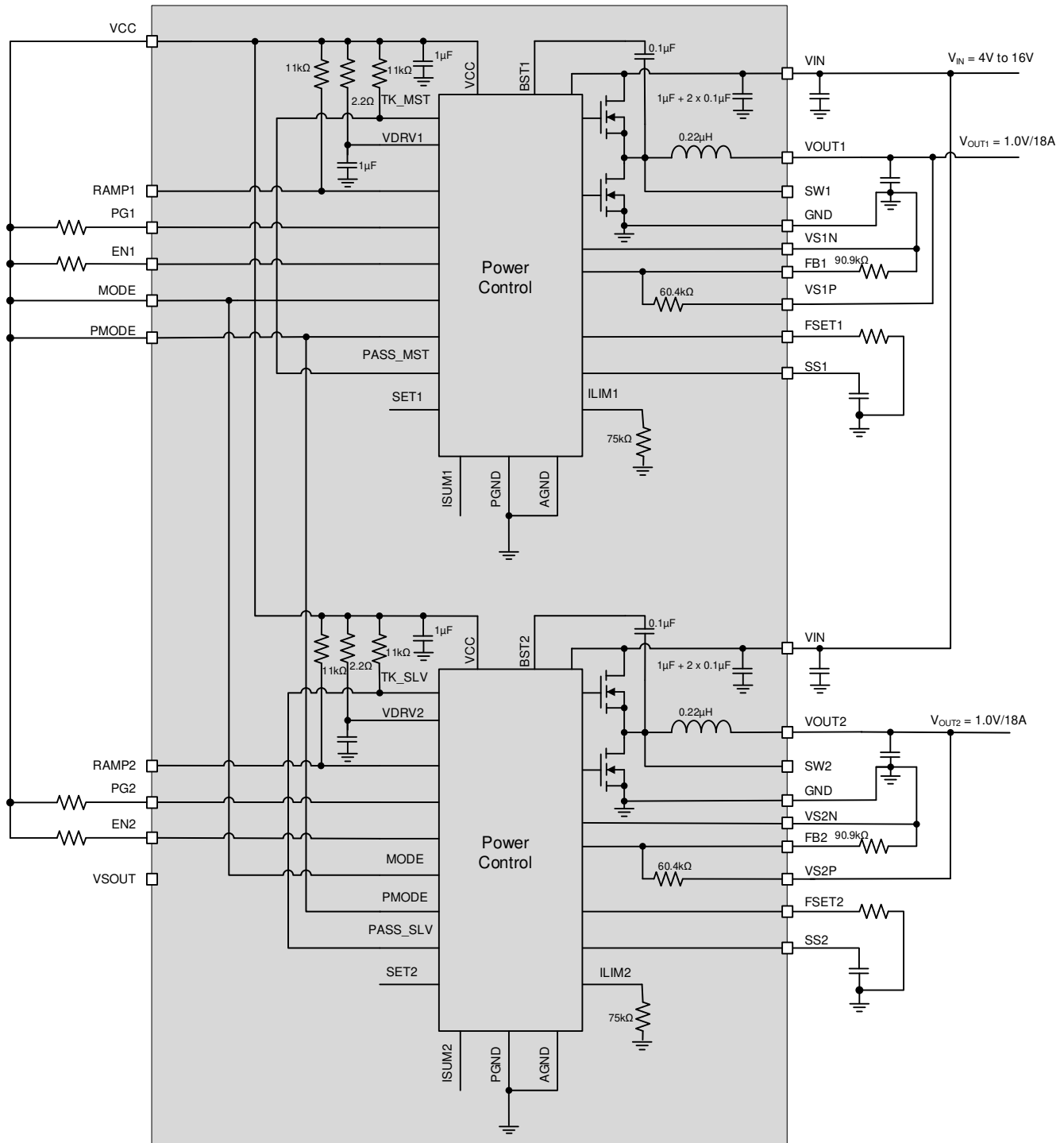

Figure 1: MPM3690-30A Functional Block Diagram

FUNCTIONAL BLOCK DIAGRAM (continued)

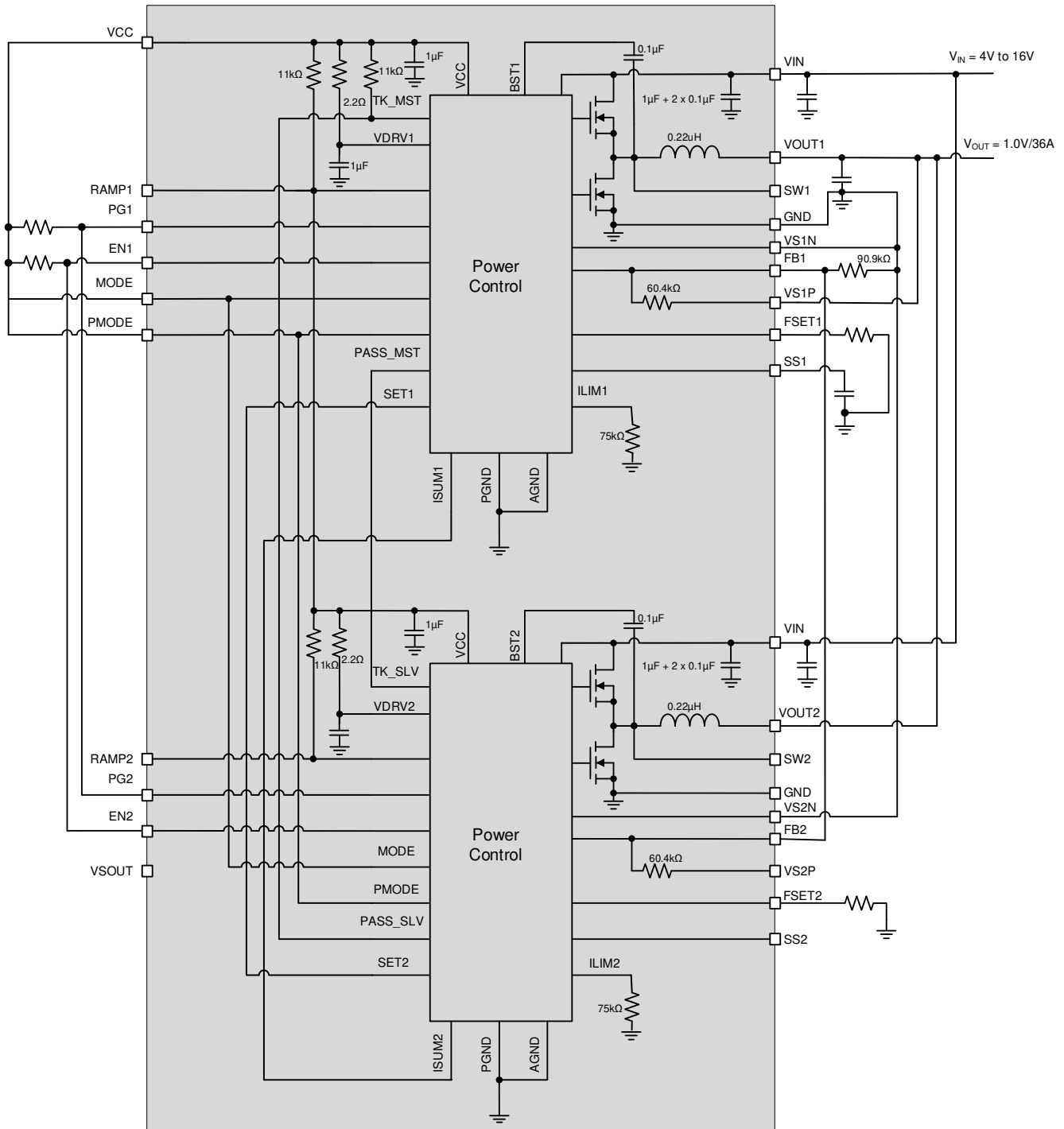

Figure 2: MPM3690-30B Functional Block Diagram



## OPERATION

### Constant-On-Time (COT) Operation

The MPM3690-30 is a dual 18A or single 36A output power module that integrates two inductors and two monolithic power ICs. The MPM3690-30 utilizes a constant-on-time (COT) control scheme to provide a fast transient response.

### Multi-Phase Operation

The MPM3690-30B adopts multi-phase constant-on-time (MCOT) control. MCOT control configures the two ICs for master and slave functionality. The slew rate of the supply voltage (VIN) during start-up must be greater than 2V/ms for MPM3690-30B.

#### MCOT Operation (Master)

The master phase performs the following functions:

- Generates the SET signals.
- Manages start-up, shutdown, and all protections.
- Monitors for any fault alerts from the slave phases through the PG pin.
- Starts the first on pulse.
- Starts the on pulse when receiving RUN and SET signals.
- Determines the on pulse width of its own phase based on the per-phase and total current.
- Sends the PASS/TAKE signal.

#### MCOT Operation (Slave)

The slave phase performs the following functions:

- Takes the SET signal from the master.
- Sends over-voltage (OV), under-voltage (UV), and over-temperature (OT) alerts to the master through the PG pin.
- Starts the on pulse when receiving RUN and SET signals.
- Determines the on pulse width of its own phase based on the per-phase and total current.
- Sends the PASS/TAKE signal.

MCOT control enables the MPM3690-30B to respond to a load step transient much faster than traditional current mode control schemes. When a load step occurs, the FB signal is below the internal reference; therefore, the SET signal is generated more frequently than during steady state to respond to the load transient. Depending on the load transient step size and slew rate, the SET signal can be generated with a minimum 50ns interval (i.e., the next phase can be turned on as fast as 50ns after the previous phase to provide ultra-fast load transient response).

### Ramp Compensation

The MPM3690-30 provides internal ramp compensation to support various types of output capacitors. The ramp value is selected with RAMP pin. Float the RAMP pin for large ramp compensation, or connect it to ground for small ramp compensation. This RAMP signal is superimposed onto the FB signal. When the superimposed RAMP + FB signal reaches the internal reference signal, the MPM3690-30 generates a new SET signal (which generates a PWM on pulse). A larger ramp value reduces system jitter, but slows load transient response. The ramp value should be selected based on the application and design target.

### MODE Setting

The MPM3690-30 only supports forced continuous conduction mode (FCCM) operation. FCCM can be enabled by setting the MODE pin to logic high.

### Soft Start

The MPM3690-30A features an adjustable soft-start time ( $t_{SS}$ ) for both output channels.  $t_{SS}$  can be programmed by connecting a soft-start capacitor ( $C_{SS}$ ) between the SS pins and GND.  $t_{SS}$  can be calculated with Equation (1):

$$t_{SS}(\text{ms}) = 30 \times C_{SS}(\mu\text{F}) \quad (1)$$

### Switching Frequency

The MPM3690-30A features an adjustable switching frequency ( $f_{SW}$ ) for both output channels. For the MPM3690-30B, the frequency resistance ( $R_{FREQ}$ ) for both channels must be the same.

$f_{SW}$  can be programmed by connecting a resistor between the FREQ pin and GND.  $f_{SW}$  can be calculated with Equation (2):

$$f_{SW}(\text{MHz}) = \frac{24}{R_T(\text{k}\Omega)} \quad (2)$$

### Output Voltage Discharge

When the MPM3690-30 is disabled through EN, it enables output voltage ( $V_{OUT}$ ) discharge. Both the high-side MOSFET (HS-FET) and the low-side MOSFET (LS-FET) are latched off. A discharge MOSFET connected between SW and GND turns on to discharge  $V_{OUT}$ . The typical on resistance of this MOSFET is about 50 $\Omega$ . Once the FB voltage ( $V_{FB}$ ) drops below 10% of the reference voltage ( $V_{REF}$ ), then the discharge MOSFET turns off.

### Protection MODE selection

The MPM3690-30 includes a protection MODE selection function. If the PMODE pin is pulled high, then the MPM3690-30 enters hiccup mode when over-current protection (OCP), over-voltage protection (OVP), or over-temperature protection (OTP) is triggered. If PMODE is pulled down to GND, then the MPM3690-30 latches off when OCP, OVP, or OTP is triggered.

### Inductor Valley Over-Current Protection

The MPM3690-30 features on-die current sense. When the LS-FET is on, the switching current (inductor current) is sensed and monitored cycle by cycle. When  $V_{FB}$  drops below  $V_{REF}$ , the HS-FET can only turn on whenever there is no over-current (OC) condition detected during the LS-FET on period. So the inductor current is limited cycle-by-cycle. If an OC condition is detected for 31 consecutive cycles, OCP is triggered. If  $V_{OUT}$  drops below the under-voltage protection (UVP) threshold during an OC condition or output short-circuit condition, the part enters OCP immediately.

Once OCP is triggered, the MPM3690-30 either enters hiccup mode or latches off, depending on the PMODE pin setting. If it latches off, cycle the power on VCC or VIN to enable the part again.

### Negative Inductor Current Limit

If the LS-FET detects a negative current below -13A, the LS-FET turns off for a set time to limit the negative current.

### Over-Temperature Protection (OTP)

The MPM3690-30 has over-temperature protection (OTP). The IC internally monitors the junction temperature. If the junction temperature exceeds 160°C, the converter shuts off.

After OTP is triggered, the MPM3690-30 either enters hiccup mode or latches off. If it latches off, cycle the power on VCC or VIN to enable the part again.

### Feedback Circuit

Connect a resistor between FB1 and VS1N and another between FB2 and VS2N to set the output voltages for the MPM3690-30A. For the MPM3690-30B, connect a resistor between FB1 and VS1N to set  $V_{OUT}$ , and tie FB1 to FB2. Connect a 60.4k $\Omega$  resistor internally between FB1 and VS1P and another between FB2 and VS2P. Figure 3 shows the block diagram.

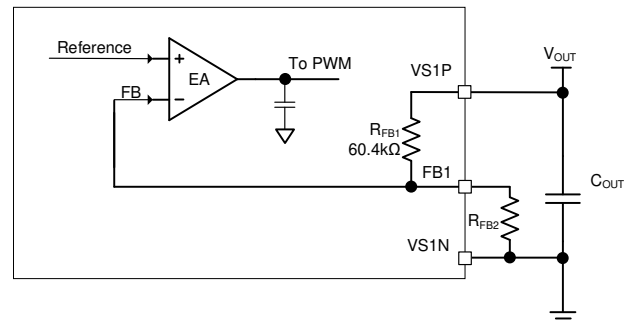

**Figure 3: MPM3690-30 Feedback Circuit**

$V_{OUT}$  can be estimated with Equation (3):

$$V_{OUT} = V_{REF} \times \left(1 + \frac{R_{FB1}}{R_{FB2}}\right) \quad (3)$$

Where  $V_{REF}$  is the reference voltage (0.6V), and  $R_{FB1} = 60.4\text{k}\Omega$ .

### Power Good (PG)

The MPM3690-30 has a power-good (PG) output for each channel. The PG pin is the open drain of a MOSFET. Connect it to VCC or an external voltage source that is below 3.6V through a pull-up resistor (typically 100k $\Omega$ ). After applying the input voltage ( $V_{IN}$ ), the MOSFET turns on so that the PG pin is pulled to GND before soft start (SS) is ready. After  $V_{FB}$  reaches the threshold, the PG pin is pulled high after a delay.

When the converter encounters any fault (e.g. UV, OV, OT, or UVLO), the PG pin is latched low. After PG is latched low, it cannot be pulled high again until a new SS is initialized.

If the input supply fails to power the MPM3690-30, PG is latched low even though it is tied to an external DC source through a pull-up resistor. Figure 4 shows the relationship between the PG voltage ( $V_{PG}$ ) and the pull-up current ( $I_{PG}$ ).

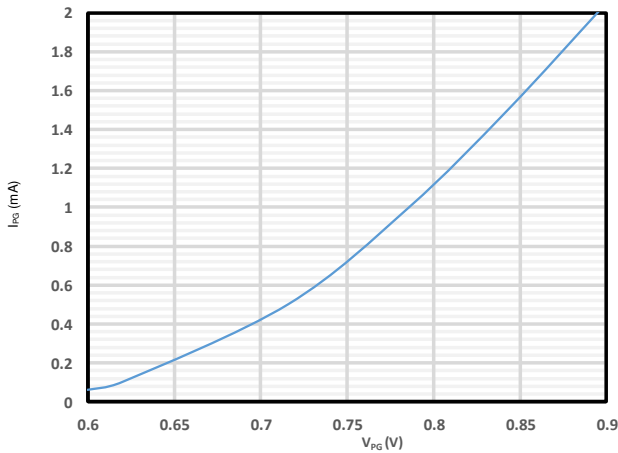

**Figure 4: PG Current vs. PG Voltage**

## APPLICATION INFORMATION

### Input Capacitor

The step-down converter has a discontinuous input current, and requires a capacitor to supply the AC current to the converter while maintaining the DC input voltage. Use ceramic capacitors for best performance. Place the input capacitors as close to the VIN pin as possible.

The capacitance can vary significantly with temperature. Capacitors with X5R and X7R ceramic dielectrics are recommended because they are fairly stable across a wide temperature range.

The capacitors must also have a ripple current rating that exceeds the converter's maximum input ripple current. Estimate the input ripple current ( $I_{CIN}$ ) with Equation (4):

$$I_{CIN} = I_{OUT} \times \sqrt{\frac{V_{OUT}}{V_{IN}} \times \left(1 - \frac{V_{OUT}}{V_{IN}}\right)} \quad (4)$$

The worst-case condition occurs at  $V_{IN} = 2 \times V_{OUT}$ , calculated with Equation (5):

$$I_{CIN} = \frac{I_{OUT}}{2} \quad (5)$$

For simplification, choose an input capacitor with an RMS current rating that exceeds half the maximum load current.

The input capacitance determines the converter's input voltage ripple. Select a capacitor that meets any input voltage ripple requirements.

Estimate the input voltage ripple ( $\Delta V_{IN}$ ) with Equation (6):

$$\Delta V_{IN} = \frac{I_{OUT}}{f_{SW} \times C_{IN}} \times \frac{V_{OUT}}{V_{IN}} \times \left(1 - \frac{V_{OUT}}{V_{IN}}\right) \quad (6)$$

The worst-case condition occurs at  $V_{IN} = 2 \times V_{OUT}$ , calculated with Equation (7):

$$\Delta V_{IN} = \frac{1}{4} \times \frac{I_{OUT}}{f_{SW} \times C_{IN}} \quad (7)$$

### Output Capacitor

The output capacitor maintains the DC output voltage. The output voltage ripple ( $\Delta V_{OUT}$ ) is estimated with Equation (8):

$$\Delta V_{OUT} = \frac{V_{OUT}}{f_{SW} \times L} \times \left(1 - \frac{V_{OUT}}{V_{IN}}\right) \times \left(R_{ESR} + \frac{1}{8 \times f_{SW} \times C_{OUT}}\right) \quad (8)$$

When using ceramic capacitors, the capacitance dominates the impedance at the switching frequency and causes the majority of the output voltage ripple. For simplification, estimate the output voltage ripple ( $\Delta V_{OUT}$ ) with Equation (9):

$$\Delta V_{OUT} = \frac{V_{OUT}}{8 \times f_{SW}^2 \times L \times C_{OUT}} \times \left(1 - \frac{V_{OUT}}{V_{IN}}\right) \quad (9)$$

When using capacitors with larger ESR (e.g. POSCAP, OSCON), the ESR dominates the impedance at the switching frequency. The output voltage ripple is determined by the ESR values. For simplification, the output ripple can be estimated with Equation (10):

$$\Delta V_{OUT} = \frac{V_{OUT}}{f_{SW} \times L} \times \left(1 - \frac{V_{OUT}}{V_{IN}}\right) \times R_{ESR} \quad (10)$$

### Low $V_{IN}$ Applications

For low  $V_{IN}$  applications ( $3V < V_{IN} < 4V$ ), an external VCC bias power supply needed. The external bias VCC must be above 2.9V (the VCC UVLO rising threshold maximum value).

**PCB Layout Guidelines**

Efficient PCB layout is critical for stable operation. For the best results, refer to Figure 5 and follow the guidelines below:

**V<sub>IN</sub>**

1. Place sufficient decoupling capacitors as close as possible to the V<sub>IN</sub> and GND pins.<sup>(6)</sup>
2. Place sufficient GND vias around the GND pad of the decoupling capacitors.<sup>(6)</sup>
3. Avoid placing sensitive signal traces close to the input copper plane and/or vias without sufficient ground shielding.
4. Use a minimum of four 22μF/25V ceramic capacitors for input channel to provide sufficient decoupling.

**V<sub>OUTx</sub>**

5. Connect each V<sub>OUTx</sub> pin together on a copper plane.
6. Place sufficient vias near the V<sub>OUTx</sub> pads to provide a current path that offers minimal

parasitic impedance.<sup>(6)</sup>

7. For the MPM3690-30B, connect all of the V<sub>OUT</sub> copper planes.

**GND**

8. Connect all of the GND pins on a copper plane.
9. Place sufficient vias close to the GND pins to provide a current return path, which minimizes thermal resistance and parasitic impedance.<sup>(6)</sup>

**V<sub>SxP</sub> and V<sub>SxN</sub>**

10. For the MPM3690-30A, route each pair of V<sub>SxP/N</sub> pins as differential signals. For MPM3690-30B, connect FB1 with FB2, and connect all V<sub>SxN</sub> pins.
11. Avoid routing V<sub>SxP/N</sub> traces close to the input plane and high-speed signals.

**Note:**

6) Sufficient quantity is determined based on the details of the individual application.

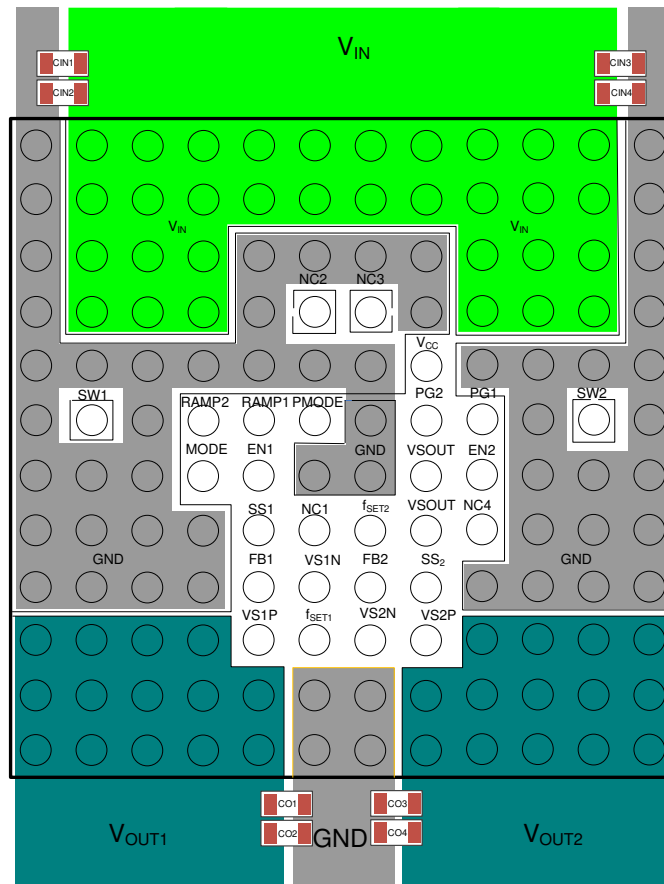

**Figure 5: Recommended PCB Layout**

## TYPICAL APPLICATION CIRCUITS

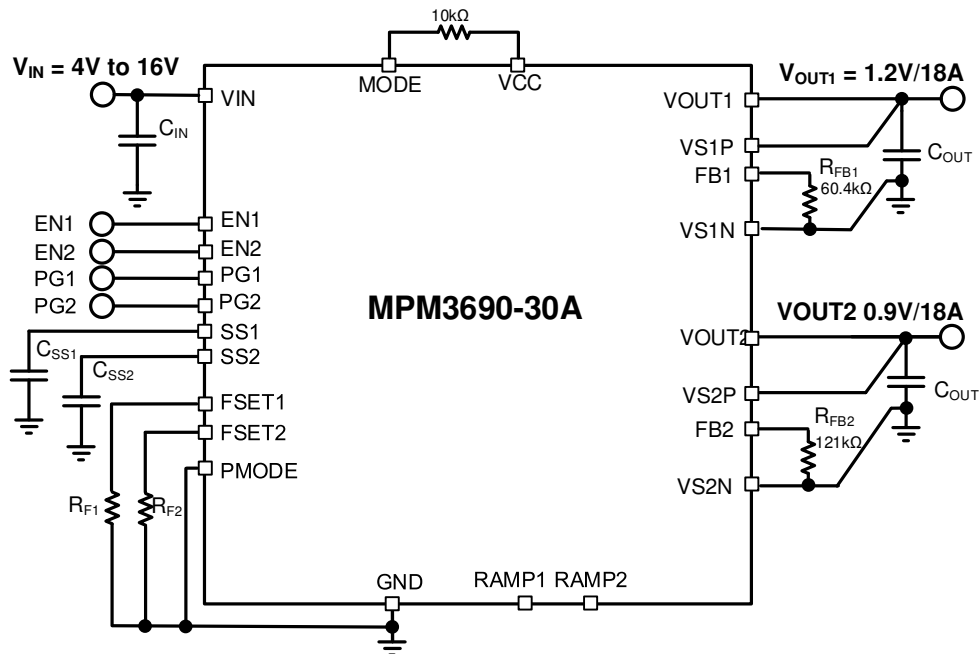

Figure 6: Typical Application Circuit (Dual-Output Operation, 1.2V and 0.9V at 18A with Remote Sense for Both Outputs)

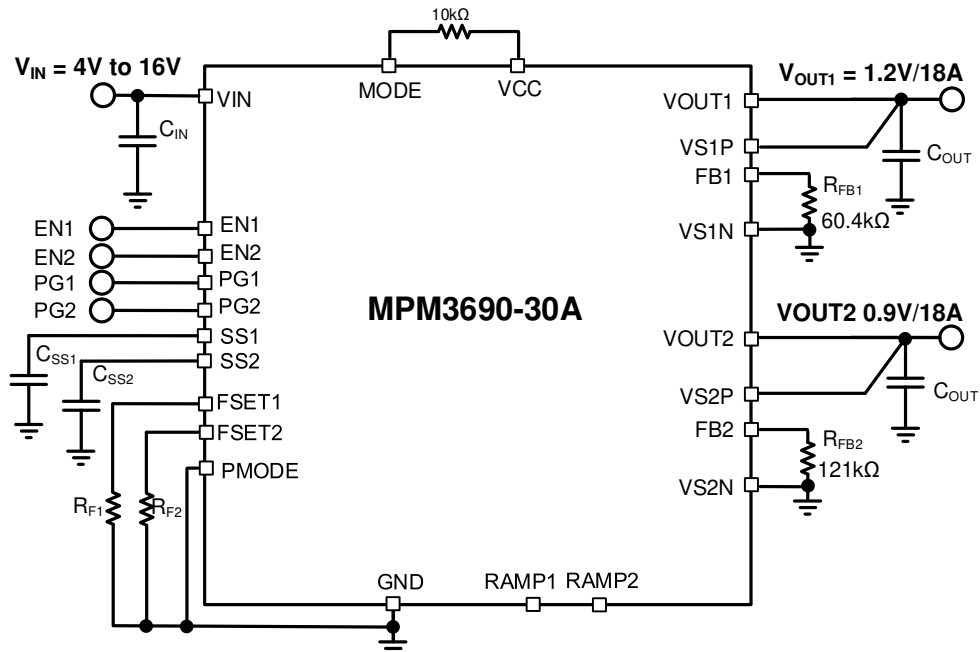

Figure 7: Typical Application Circuit (Dual-Output Operation, 1.2V and 0.9V at 18A with Remote Sense Disabled)

TYPICAL APPLICATION CIRCUITS (continued)

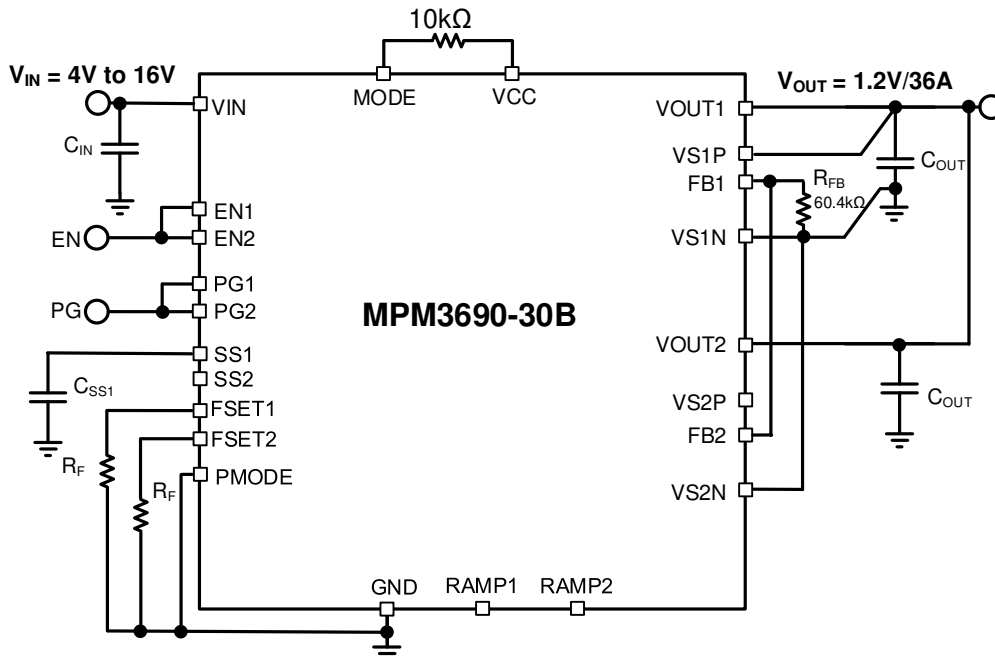

Figure 8: Typical Application Circuit (Interleaved Operation, 1.2V at 36A with Remote Sense)

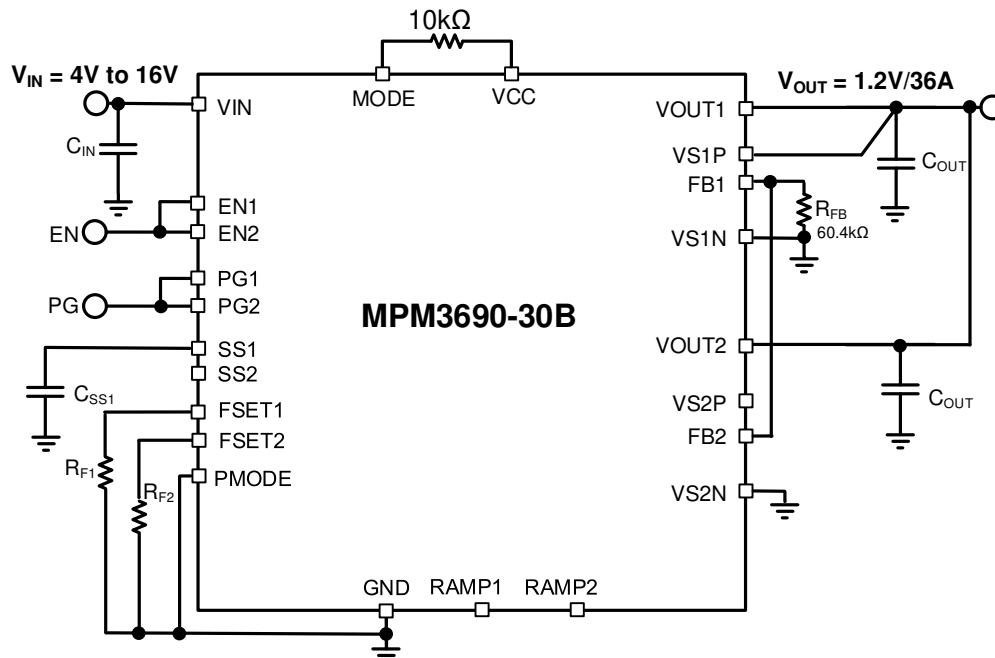
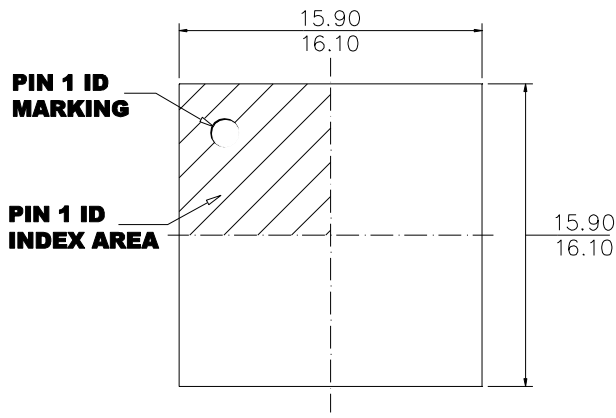

Figure 9: Typical Application Circuit (Interleaved Operation, 1.2V at 36A without Remote Sense)

# PACKAGE INFORMATION

BGA (16mmx16mmx5.18mm)



**TOP VIEW**

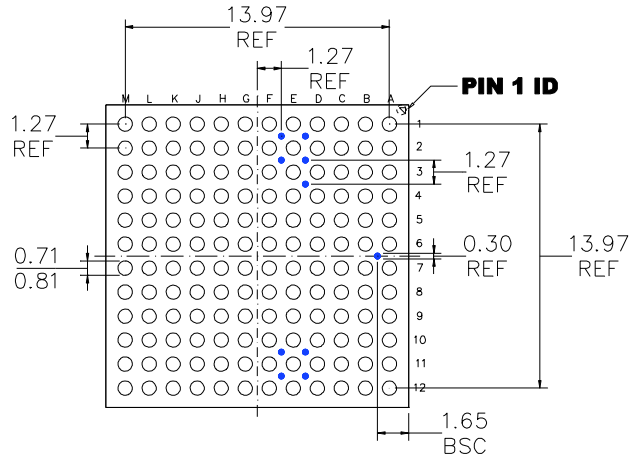

**BOTTOM VIEW**

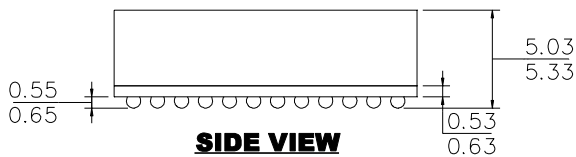

**SIDE VIEW**

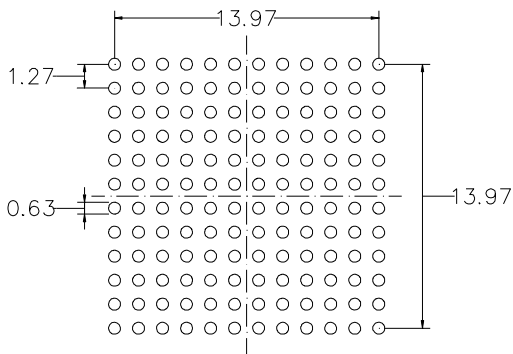

**RECOMMENDED LAND PATTERN**

**NOTE:**

- 1) THE SOLID BLUE CIRCLES REPRESENT TEST PADS WITHOUT SOLDER BALL.
- 2) ALL DIMENSIONS ARE IN MILLIMETERS.
- 3) LEAD COPLANARITY SHALL BE 0.10 MILLIMETERS MAX.
- 4) JEDEC REFERENCE IS MO-275A.
- 5) DRAWING IS NOT TO SCALE.



### CARRIER INFORMATION

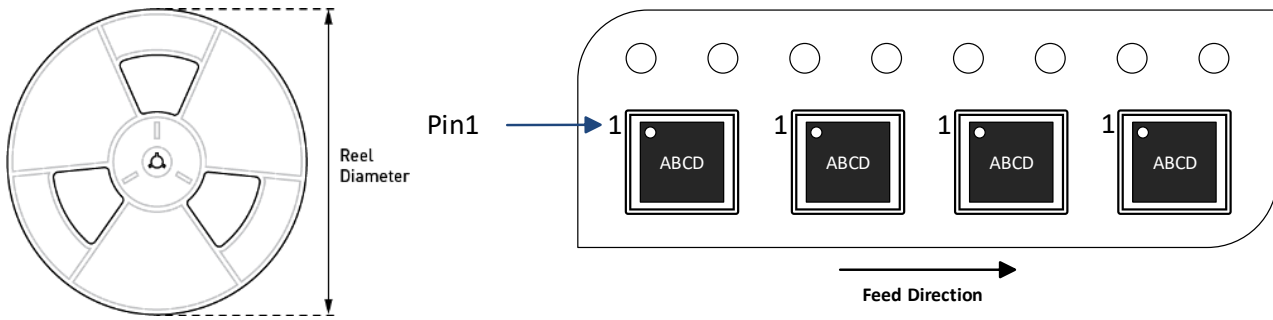

Part Number	Package Description	Quantity/ Reel	Quantity/ Tray	Quantity/ Tube	Reel Diameter	Carrier Tape Width	Carrier Tape Pitch
MPM3690GBF-30A	BGA (16mmx16mmx5.18mm)	N/A	90	N/A	N/A	N/A	N/A
MPM3690GBF-30B							

## REVISION HISTORY

Revision #	Revision Date	Description	Pages Updated
1.0	5/11/2021	Initial Release	-

**Notice:** The information in this document is subject to change without notice. Please contact MPS for current specifications. Users should warrant and guarantee that third-party Intellectual Property rights are not infringed upon when integrating MPS products into any application. MPS will not assume any legal responsibility for any said applications.