

REVISIONS			
REV	DESCRIPTION, ECN, EAR NO.	DATE	APP'D
A	PROPOSAL	MAR15/18	L.CHAN

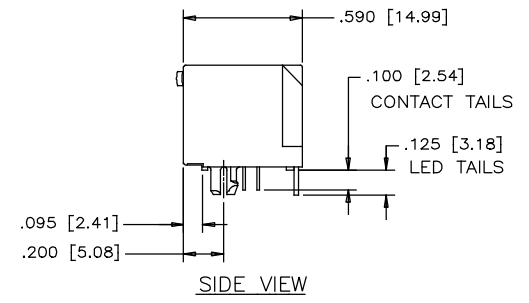

FRONT VIEW

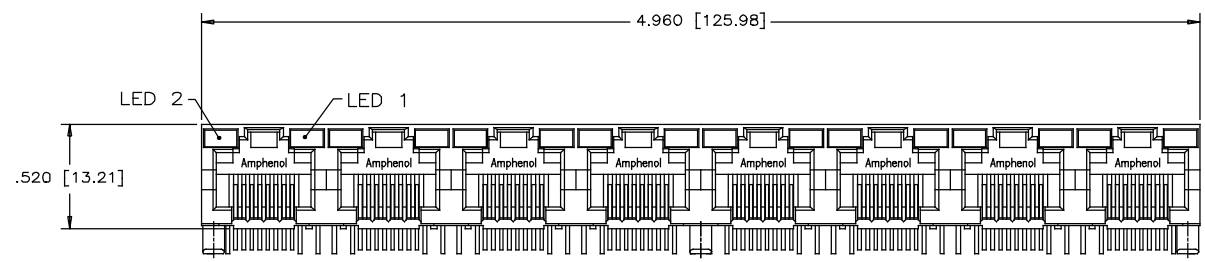
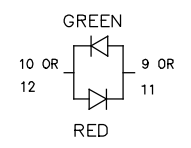
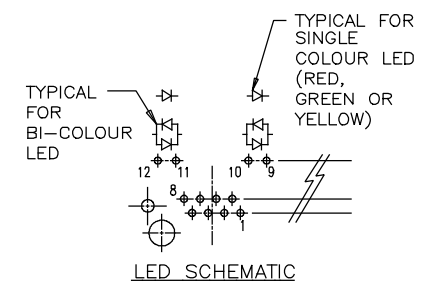
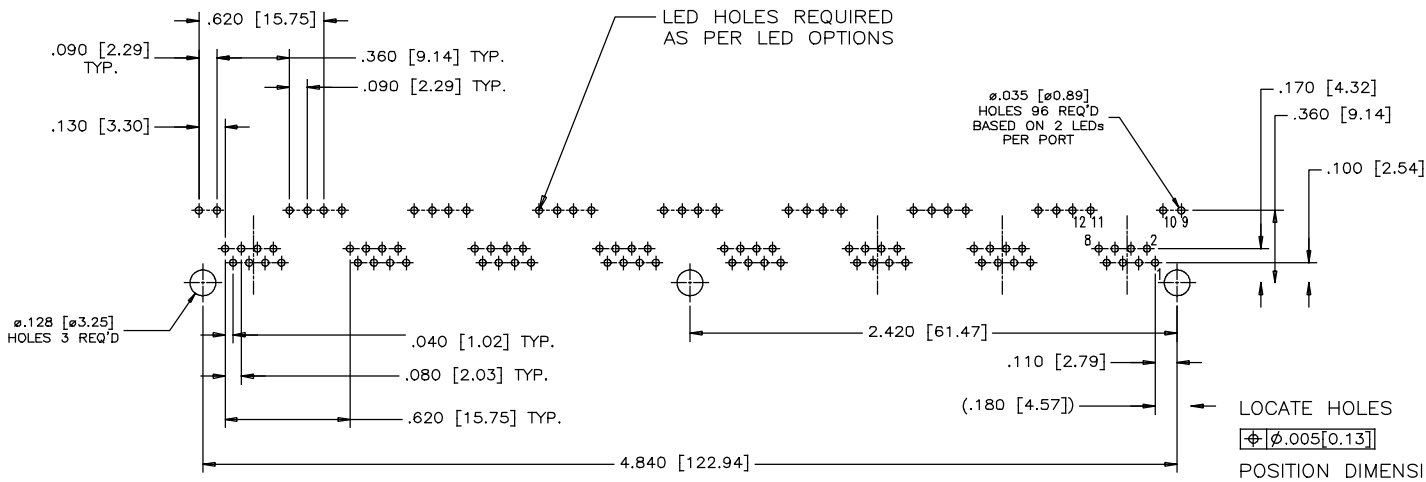

RECOMMENDED P.C.B. LAYOUT (COMPONENT SIDE OF BOARD)

LOCATE HOLES
 $\phi \pm 0.005 [0.13]$
 POSITION DIMENSIONS ARE BASIC

BI-COLOUR LED DETAIL (GREEN/YELLOW AND GREEN/ORANGE LED'S ARE ALSO AVAILABLE)

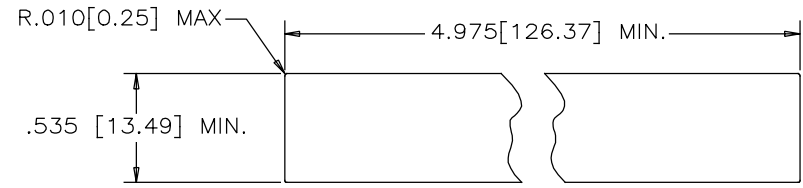

RECOMMENDED PANEL CUTOUT

PART NUMBER: RJHSE-X08X-08

GOLD PLATING

- E=RJ45 FLAT CONTACT 6u"
- G=RJ45 FLAT CONTACT 15u"
- J=RJ45 FLAT CONTACT 30u"
- 5=RJ45 FLAT CONTACT 50u"

REFER TO LED OPTIONS DRAWING FOR ORDERING CODES

MATERIALS:
 PLASTIC HOUSING: HIGH TEMPERATURE THERMOPLASTIC
 FLAMMABILITY RATING UL 94V-0, COLOR BLACK

CONTACTS: PHOSPHOR BRONZE
 PLATING: GOLD PLATING ON MATING SURFACE.
 [SEE PART NUMBER FOR THICKNESS]
 50 μ" [1.27 MICRONS]
 MIN. NICKEL UNDERPLATE
 100 μ" [2.54 MICRONS]
 MIN. MATTE TIN ON CONTACT TAILS.

UNLESS SPECIFIED OTHERWISE	DRAWN <i>W.QIU</i>	DATE <i>MAR15/18</i>
PRIMARY UNITS INCH	CHECKED <i>L.CHAN</i>	<i>MAR15/18</i>
SECONDARY MILLIMETER	M.E. APP'D	
REFERENCE IN PARENTHESES	Q.A. APP'D	
GENERAL TOLERANCES	DWG APPR.	
1 DECIMAL PLACE ±0.025	ENG. REL. NO.	
2 DECIMAL PLACES ±0.020	REF.	
3 DECIMAL PLACES ±0.015	THIRD ANGLE PROJECTION	
ANGULAR DEGREES ±1.0°	DO NOT SCALE DRAWING	

Amphenol Canada Corp.
 www.amphenolcanada.com

TITLE: EIGHT-PORT HIGH SPEED MODULAR JACK, 8 POSITIONS, 8 CONTACTS, UNSHIELD WITH LED, -RoHS COMPLIANT

DWG. NO. **P-RJHSE-X08X-08** REV **A**

CODE ID NO. 03554 DWG SIZE: C SCALE: N/A SHEET 1 OF 1

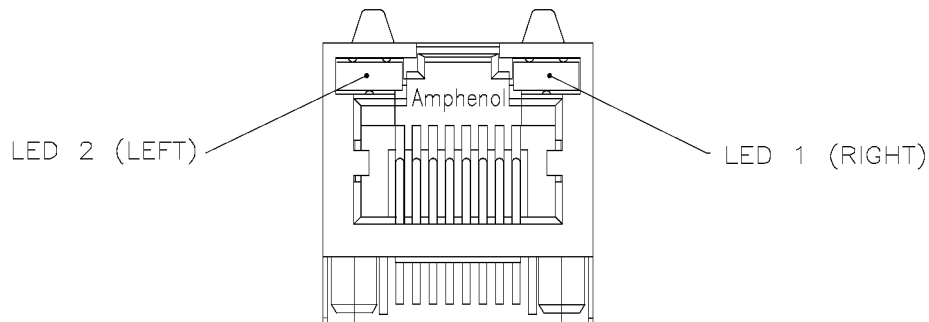

TYPICAL FOR SINGLE & MULTI-PORT



EXAMPLE:

PART NUMBER RJHSE-538X



CODE	LED 2 (LEFT)	LED 1 (RIGHT)	CODE	LED 2 (LEFT)	LED 1 (RIGHT)	CODE	LED 2 (LEFT)	LED 1 (RIGHT)
0	BLOCKED	BLOCKED	9	GREEN	BLOCKED	J	BiC RD/GR	YELLOW
1	YELLOW	GREEN	A	BiC GR/YE	BiC GR/YE	K	YELLOW	BiC GR/OR
2	BLOCKED	GREEN	B	BiC RD/GR	BiC RD/GR	L	BiC GR/YE	RED
3	YELLOW	BLOCKED	C	BiC RD/GR	BiC GR/YE	M	RED	YELLOW
4	GREEN	YELLOW	D	GREEN	BiC GR/YE	N	BiC GR/RD	BiC GR/YE
5	GREEN	GREEN	E	YELLOW	BiC GR/YE	P	GREEN	BiC RD/GR
6	YELLOW	YELLOW	F	BiC GR/YE	YELLOW	R	BiC GR/OR	GREEN
7	RED	GREEN	G	BiC GR/OR	BiC GR/OR	T	RED	RED
8	GREEN	RED	H	BiC GR/YE	GREEN	V	BiC RD/GR	GREEN
						W	ADDITIONAL	OPTIONS

EXAMPLE OF ADDITIONAL LED OPTIONS:

PART NUMBER RJHSE-538W-01Y



CODE	LED 2 (LEFT)	LED 1 (RIGHT)	CODE	LED 2 (LEFT)	LED 1 (RIGHT)	CODE	LED 2 (LEFT)	LED 1 (RIGHT)
0	DO NOT USE		5	BLOCKED	YELLOW	E	BiC GR/YE	BiC GR/RD
1	RED	BLOCKED	6	RED	BiC RD/GR	A	LOWC YE	LOWC YE
2	BiC GR/OR	YELLOW	7	BLOCKED	BiC RD/GR	B	LOWC YE	LOWC GR
3	YELLOW	RED	8	BiC RD/GR	BLOCKED	C	LOWC GR	LOWC YE
4	BLOCKED	RED	9	BiC GR/YE	BLOCKED	D	LOWC GR	LOWC GR
			N	BLUE	RED	M	LOWC RD	LOWC YE

REVISIONS				
SYM	ZONE	ECN, ERN NO.	DATE	APPRD.
B		ADD LED CODE N	AUG16/12	L.C
C		UPDATE RoHS STAMP	AUG30/13	L.C
D		UPDATE SPEC.	MAY07/14	L.C
E		UPDATE SPEC.	APR19/17	L.CHAN

LED SPECIFICATIONS:

FORWARD VOLTAGE: 2.1 VOLTS TYP.
 REVERSE VOLTAGE: 5.0 VOLTS MIN.
 LUMINOUS INTENSITY: 0.5 mCd MIN.

(AT If=2mA)

OPERATING TEMPERATURE: -55° TO 85° C

LEAD SOLDERING TEMPERATURE: 260° C
 (5 SEC, 1/16" FROM CASE)

PLATING ON TAILS: TIN OR TIN/COPPER
 ALLOY OVER SILVER

PRIMARY COLOR FOR BI-COLOR
 LEDS IN STANDARD ANODE/
 CATHODE CONFIGURATION IS:
 RED-GREEN= RED
 RED-YELLOW= RED
 GREEN-YELLOW= GREEN
 GREEN-ORANGE= GREEN

LEGEND

BiC=BI-COLOR LED
 LOWC=LOW CURRENT LED
 YE=YELLOW
 GR=GREEN
 RD=RED
 OR=ORANGE

NOTE:

THE TWO DIGITS PRECEDING THE
 ADDITIONAL LED CODE MUST BE
 USED IN THE PART NUMBER, WHEN
 ORDERING ANY OF THE ADDITIONAL
 LED OPTIONS.

DRAWN K. LAMBIE	DATE SEP21/04
DESIGNED	
CHECKED	
I. E. APPRD.	
Q. A. APPRD.	
DWG. APPRD.	
ENG. REL. NO.	
REF.	
DIMENSIONS ARE IN INCHES [mm]	CODE ID. NO. 03554

Amphenol Canada Corp.

TITLE
 LED OPTIONS FOR RJHSE, SINGLE
 OR MULTI-PORT CONNECTORS
 - RoHS COMPLIANT

DWG	DRAWING NO.	REV.
	P-RJHSE-LEDS	E
SCALE	WT. -----	SURF. -----
		SHEET 7 of 7

THIS DOCUMENT CONTAINS PROPRIETARY INFORMATION AND SUCH INFORMATION
 MAY NOT BE DISCLOSED TO OTHERS FOR ANY PURPOSE OR USED FOR MANUFACTURING
 PURPOSES WITHOUT WRITTEN PERMISSION FROM AMPHENOL CANADA CORP.