



## Key Features

- Eight 10/100/1000BASE-T ports with integrated PHYs.
- One QSGMII port.
- Two 1000FX/2500FX (SGMII+) or 10000FX XFI/SFI ports.
- An integrated ARM Cortex-M7 CPU.
- An RGMII, MII, and RvMII port to connect to an external CPU (or to be used as a 1GbE customer port).
- Cascading that enables the creation of unified, single-CPU managed, 15- to 28-port switch.
- Support for advanced QoS, CFP, VLAN manipulation, up to L4 classification via CFP, and Time Sensitive Networking (TSN).
- Support for the IEEE 802.1BR port extender.
- Power-saving green technology per IEEE 802.3az Energy Efficient Ethernet.
- Support for commercial (0°C to 70°C) ambient temperature.

## Applications

- Industrial Ethernet
- Unmanaged/web-managed/managed SMB switches
- Home gateway MDU
- Port extender

# BCM5315X

## Multiport GbE Switch Series with Integrated PHYs and 10GbE Uplinks

### Description

The Broadcom® BCM5315X family of highly integrated Gigabit-Ethernet (GbE) switches is designed for high-end and cost-effective 1GbE and above applications. The switch family supports eight 10/100/1000BASE-T ports (with integrated GPHYs), one QSGMII port, and an additional one or two high-speed 2.5GbE SGMII, or 10GbE XFI/SFI ports.

The BCM5315X family is optimally designed for Gigabit-Ethernet SMB, Industrial, and service provider applications that take advantage of high-speed uplinks connectivity of 2.5GbE/10GbE speeds. This switch family is based on the industry-leading 28 nm RoboSwitch™ architecture, also known as Robo-2. The products in this family integrate the powerful ARM Cortex-M7 CPU that enables customers to design switching platforms without adding an external processor. These products are also equipped with the high-end forwarding mechanisms required in many advanced applications. These mechanisms include an advanced QoS engine, flexible content filter processor (CFP), sophisticated VLAN manipulation capability, security features, packet synchronization for time-sensitive networks, and many more.

The BCM5315X family of switches is supported by several software packages designed for various applications. Basic, unmanaged software can be used to construct unmanaged switches with basic functionalities and no VLAN segregation. Web-managed software (such as ROBO-OS™) can be used to build web-controlled switches while full-featured SDK software can be used to construct managed devices that are controlled by an external CPU. For example, home gateways and Ethernet MDU switches can connect the BCM5315X switches to an external PON or DSL SoC.

The BCM5315X family of switches can be used to construct standalone platforms with low port-count configuration (up to 15 ports), or a cascaded design with double port-count switches by connecting two devices back-to-back.

The BCM5315X switches are offered to customers in commercial-grade ambient temperature.

### Benefits

- Support for cascading mode that enables the creation of a unified, single-CPU managed, 16- to 26-port switch.
- Support for high-end QoS capabilities with hierarchical scheduling, eight egress buffer queues per port each with its own shaper, WRED and Tail-drop congestion avoidance, and dual *leaky bucket* ingress rate limiters (also known as policers).
- Advanced CFP (such as an access-list engine) that can classify up to L4 headers.

## Benefits (con't)

- Support for virtual switching instances (VSI) for explicit segregation of bridging domains with advanced VLAN translation and encapsulation (for example, MAC-in-MAC).
- Port-extender support, per IEEE 802.1BR, for designing modular chassis devices or *pizza box* platforms with remote port extensions.
- Advanced TSN protocol support, such as IEEE 802.1Qav, 802.1Qbv, 802.1ASrev, and 802.1Qci, for scheduling time-critical traffic streams across an entire network domain.
- Delivered with unmanaged software, web-managed software, or two different managed SDK software (RoboSwitch SDK and Network Switch SDK).

BCM5315X Block Diagram

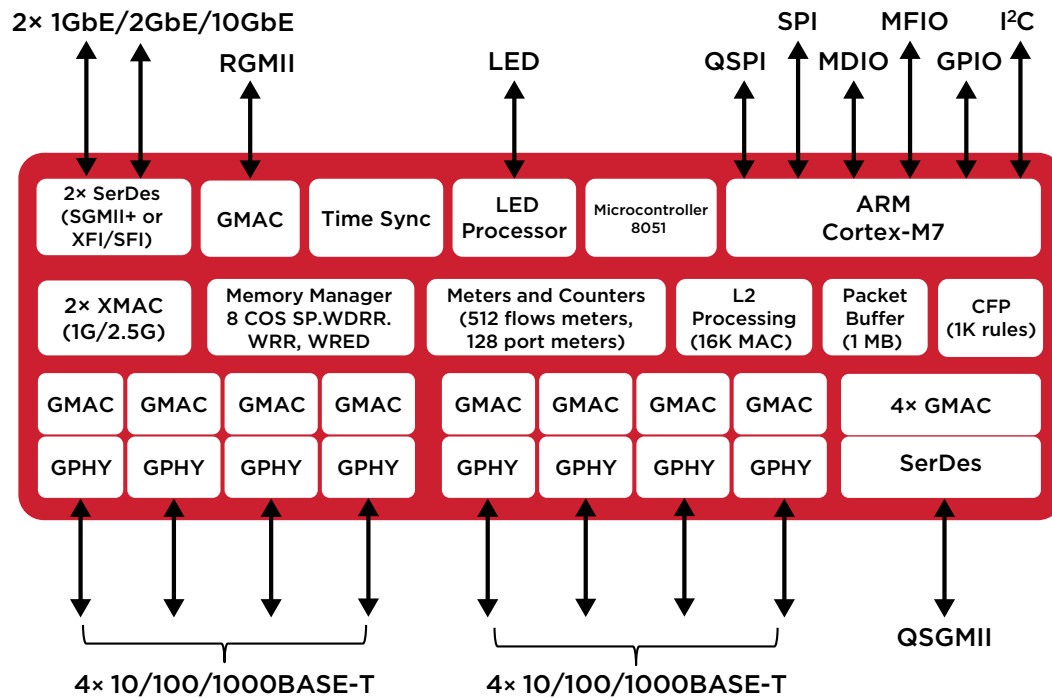

Ordering Information			
Description	Ambient Temperature	Package	Device ID
Intelligent, unmanaged GbE Robo-2 switch with 8x 10/100/1000BASE-T ports with integrated GPHYs + 1x 10000FX XFI/SFI port	Commercial (0°C to 70°C)	13 mm x 13 mm	BCM53156XUKFBG
Intelligent, managed GbE Robo-2 switch with 8x 10/100/1000BASE-T ports with integrated GPHYs + 1x 10000FX XFI/SFI port	Commercial (0°C to 70°C)	13 mm x 13 mm	BCM53156XMKFBG
Intelligent, unmanaged GbE Robo-2 switch with 8x 10/100/1000BASE-T ports with integrated GPHYs + 1x QSGMII port + 2x 1000FX/2500FX/10000FX XFI/SFI ports	Commercial (0°C to 70°C)	13 mm x 13 mm	BCM53158XUKFBG
Intelligent, port-extender GbE Robo-2 switch with 8x 10/100/1000BASE-T ports with integrated GPHYs + 1x QSGMII port + 2x 1000FX/2500FX/10000FX XFI/SFI ports	Commercial (0°C to 70°C)	13 mm x 13 mm	BCM53158XPKFBG
Intelligent, managed GbE Robo-2 switch with 8x 10/100/1000BASE-T ports with integrated GPHYs + 1x QSGMII port + 2x 1000FX/2500FX/10000FX XFI/SFI ports	Commercial (0°C to 70°C)	13 mm x 13 mm	BCM53158XMKFBG