

THIS DRAWING IS UNPUBLISHED.

RELEASED FOR PUBLICATION

ALL RIGHTS RESERVED.

© COPYRIGHT - By -

LOC AF DIST 50

REVISIONS

P	LTR	DESCRIPTION	DATE	DWN	APVD
T1		REVISED PER ECR-20-009164	11AUG2020	MK	DH

1 CONTINUOUS STRIP ON REELS

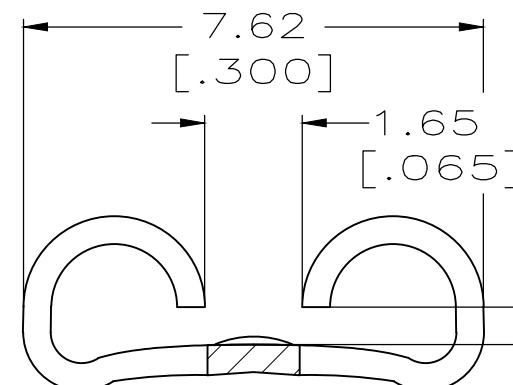
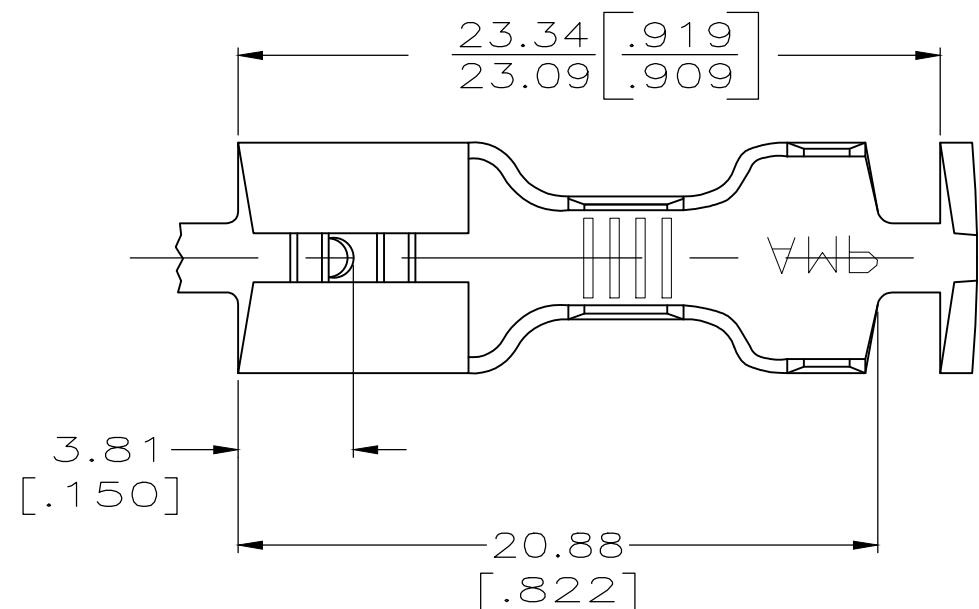

VIEW A-A SCALE 8:1

GAP AS REQUIRED TO MEET FORCE SPECIFICATIONS AND 0.71 [.028] MAX

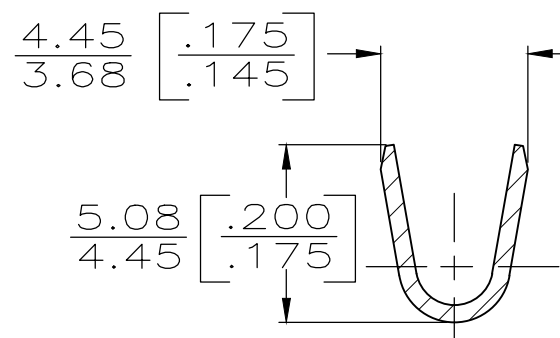
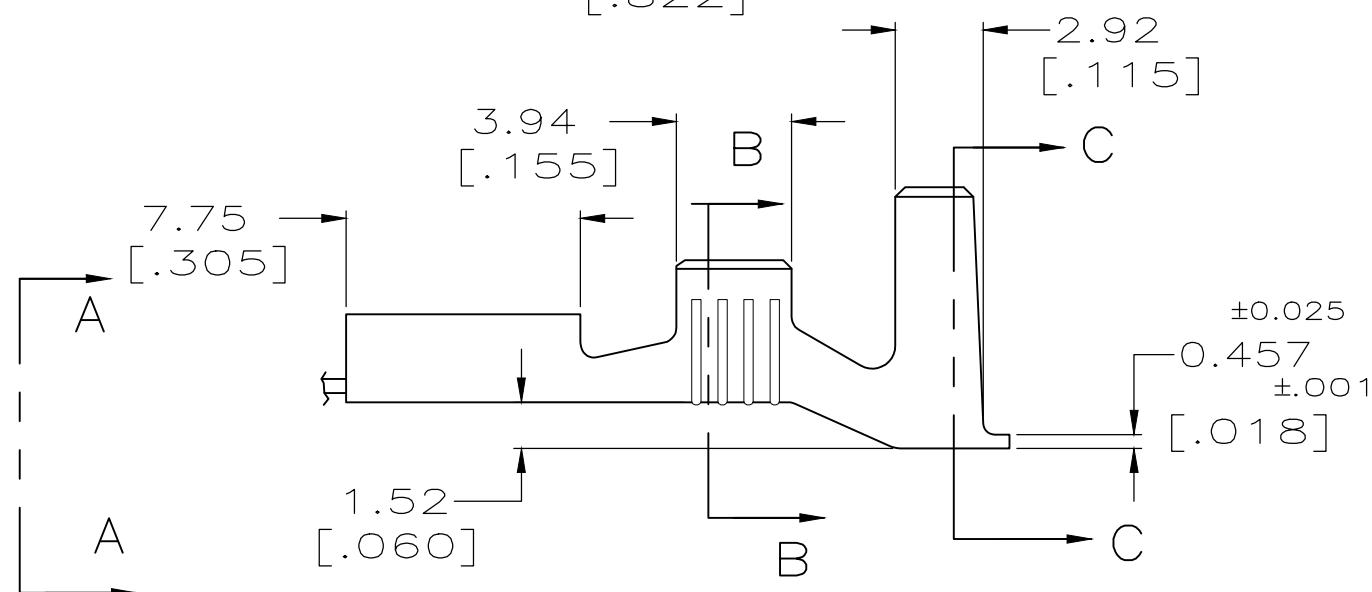

SECTION B-B SCALE 5:1

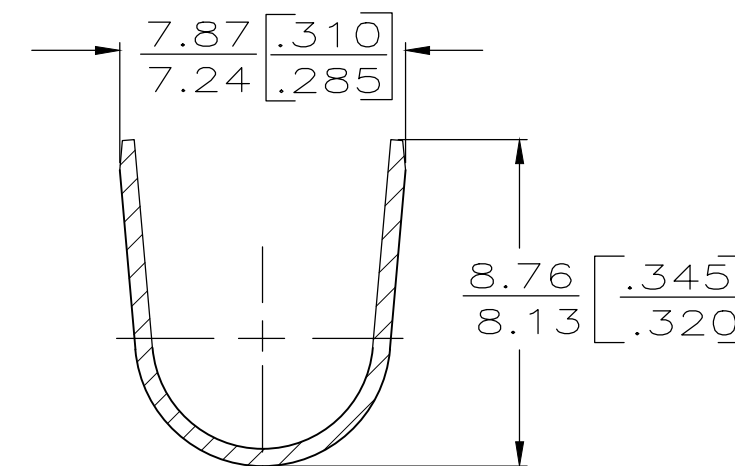

SECTION C-C SCALE 5:1

5.33-6.73 or (2) 3.05 [.210-.265] or (2) [.120]	1.3-3.0mm <sup>2</sup> or (2) 0.8mm <sup>2</sup> [16-12] or (2) [#18's]	0.84-0.76 [.033-.030]	41728
INSULATION RANGE	WIRE SIZE	MATING TAB THK	PART NO.

THIS DRAWING IS A CONTROLLED DOCUMENT.		DWN JR RUTH 7/10/89	<b>STE</b> TE Connectivity	
DIMENSIONS: mm [INCHES]		CHK MS FEHER 7/10/89		
TOLERANCES UNLESS OTHERWISE SPECIFIED:		APVD R KUZO 7/10/89	NAME RECEPTACLE, FASTON, .250 SERIES	
0 PLC ± -		PRODUCT SPEC -	SIZE CAGE CODE DRAWING NO RESTRICTED TO	
1 PLC ± -		APPLICATION SPEC -	A3 00779 C-41728	
2 PLC ± -		WEIGHT -	SCALE 4:1 SHEET 1 OF 1 REV T1	
3 PLC ± 0.38 [.015]		CUSTOMER DRAWING		
4 PLC ± -				
ANGLES ± -				
MATERIAL FINISH				
BRASS TIN				