

# PRODUCT DATA DRAWING

CAD GENERATED DRAWING	DCN CONTROLLED DOCUMENT	DWG. NO. <b>SF1122-6032</b>
-----------------------------	-------------------------------	--------------------------------

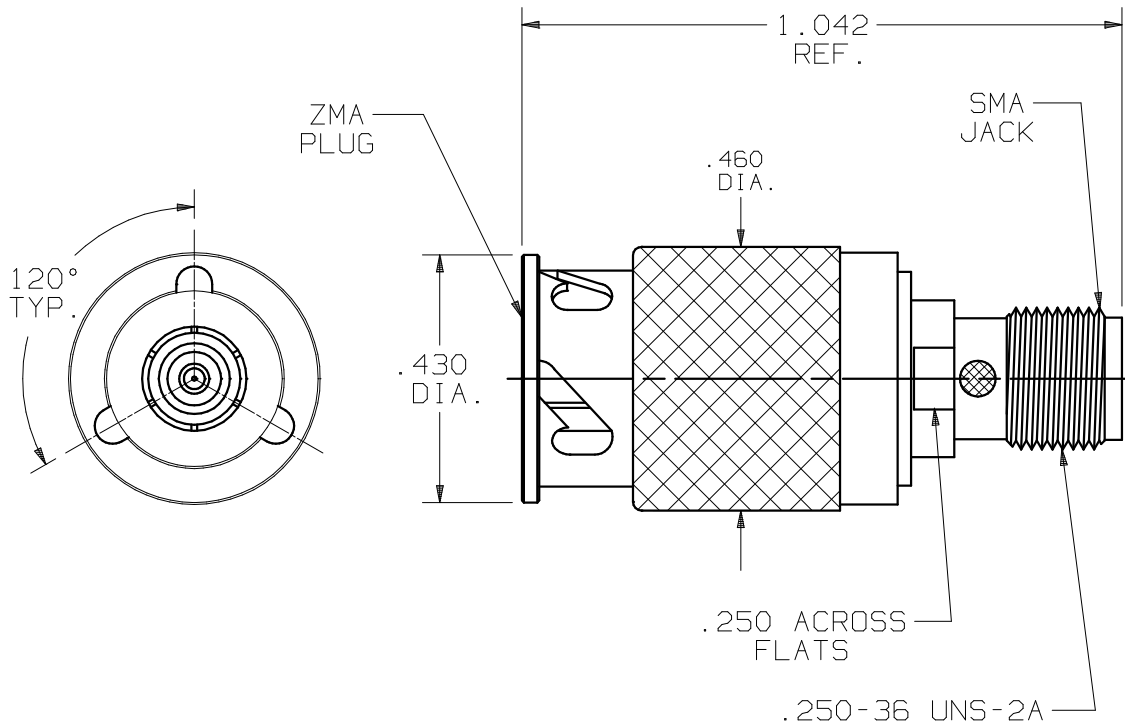

**MATERIALS:**

BODY,  
WASHERS,  
COUPLING NUT: STAINLESS STEEL PER  
AMS-5640, UNS S30300 (TYPE I), COND. A  
  
INSULATOR: TEFLON PER ASTM-D-1457.  
  
CONTACTS &  
LOCK RING: BERYLLIUM COPPER PER ASTM-B196  
COND. TDO4, ALLOY UNS-C17300.  
  
SPRING: 17-7 PH STAINLESS STEEL.

**FINISHES:**

BODY,  
SPRING,  
WASHERS,  
COUPLING NUT: PASSIVATE PER QQ-P-35C  
  
CONTACTS: GOLD PER MIL-G-45204, TYPE I,  
GRADE C, CLASS 0 OVER NICKEL PER QQ-N-290  
CLASS 1

**ELECTRICAL:**

IMPEDANCE: 50 OHMS  
FREQ. RANGE: DC-12.4 GHz  
D.W.V.: 1000 VRMS  
INSUL. RES.: 5,000 MEGOHMS MIN

SYM.	DESCRIPTION	DATE	APPR.	UNLESS OTHERWISE SPECIFIED: 1) ALL DIMENSIONS ARE AFTER PLATING. 2) BREAK CORNERS & EDGES .005 R. MAX. 3) CHAM. 1st & LAST THDS. 4) SURFACE ROUGHNESS 63 J MIL-STD-10. 5) DIAS. ON COMMON CENTERS TO BE CONCENTRIC WITHIN .005 T.I.R. 6) REMOVE ALL BURRS.	DIMENSIONS ARE IN INCHES TOLERANCES: DECIMALS      FRACTIONAL      ANGULAR .X ±.030                                  X° ±1°0' .XX ±.015                                 ±1/64                                 X'X' ±15' .XXX ±.005			<b>SV Microwave, Inc.</b> 2400 Centrepark West Drive, Suite 100 West Palm Beach, FL 33409	
—	REL. DCN 24935	12/98	JM		MATERIAL: SEE P/L	TITLE: SMA JACK TO 120° ZMA PLUG ADAPTER			
A	REV. DCN 28217	04/02	STW		FINISH: SEE P/L	AREA: N/A	DWG. NO. SF1122-6032		
					DRAWN: VMJ 12/03/98	SIZE A	CAGE NO. 95077		
					CHECKED: JM 12/04/98	SCALE 3X			
					APPROVED: JM 12/04/98				