

Directive 2002/95/EC
RoHS
Compliant

NOTES:

1. RoHS COMPLIANT
2. FOR WAVESOLDERING (SOLDER BATH TEMPERATURE 260°C FOR 5 SEC. AND SOLDER PREHEAT 100°C FOR 30 SEC.)
3. METALSHELLS: STEEL; min. 315µin TIN over 40-80µin NICKEL
4. INSULATORS: HIGH TEMPERATURE PLASTIC UL 94 V-0, BLACK
5. CONTACTS: COPPER ALLOY
PLATING: 8µin HARD GOLD over min. 50µin NICKEL
CONTACT TAILS PRETINNED
6. METAL BRACKETS: ZINC DIE CAST; 300µin COPPER/40-120µin NICKEL/120-200µin TIN
7. THREADED INSERTS: COPPER ALLOY; min. 200µin TIN over 80µin NICKEL
8. FIXING-PLATE: HIGH TEMPERATURE PLASTIC UL 94 V-0; BLACK
9. CAPACITANCE: 830pF±20%
10. DIELECTRIC WITHSTANDING VOLTAGE: 424 VDC
11. MAXIMUM TORQUE VALUE FOR THREAD: 6 in.LB
12. CONNECTOR IS PART MARKED: 242A12440X CONEC ABC

APPROVAL # FREIGABE # DEBLOCAGE # AUTORIZACION # APPROVAL	
CUSTOMER APPROVAL DATE:	
NAME:	TITLE:
COMPANY NAME:	
APPROVAL # FREIGABE # DEBLOCAGE # AUTORIZACION # APPROVAL	

THIS DRAWING MAY NOT BE COPIED OR REPRODUCED IN ANY WAY, AND MAY NOT BE PASSED ON TO A THIRD PARTY WITHOUT WRITTEN PERMISSION. OWNERSHIP AND COPYRIGHT OF CONEC GmbH				tolerance		dim. in mm	scale: 2:1 (5:1)	
DO NOT ALTER CAD DRAWING BY HAND				date	name		material: SEE NOTES	
rev.	description	date	name	drawn	27.10.09	Petker	title: D-SUB FILTER FEMALE 90° 25pos. 0.318inch with threaded insert and metal bracket	
a	Origin			appd.	27.10.09	Fischer		
				norm				
				d-old				
						dwg no: Inventor 10		DIN-A3
						part no: 242A12440X		sh: 1

dwg no: Inventor 10		DIN-A3
part no: 242A12440X		sh: 1

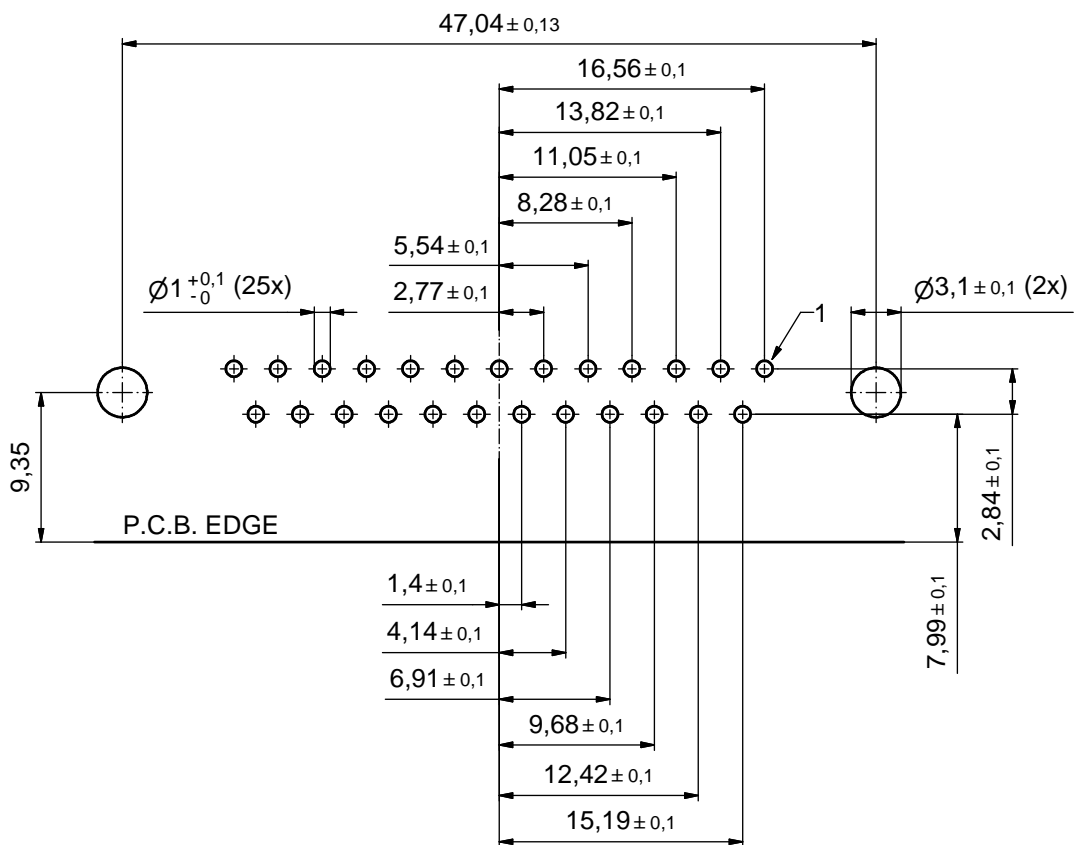

P.C.B. HOLE DRILLINGS
(P.C.B. TOP SIDE)

APPROVAL # FREIGABE # DEBLOCAGE # AUTORIZACION # APPROVAL	
CUSTOMER APPROVAL DATE:	
NAME:	TITLE:
COMPANY NAME:	
APPROVAL # FREIGABE # DEBLOCAGE # AUTORIZACION # APPROVAL	

THIS DRAWING MAY NOT BE COPIED OR REPRODUCED IN ANY WAY, AND MAY NOT BE PASSED ON TO A THIRD PARTY WITHOUT WRITTEN PERMISSION. OWNERSHIP AND COPYRIGHT OF CONEC GmbH				tolerance		dim. in mm	
DO NOT ALTER CAD DRAWING BY HAND				date	name		
rev.	description	date	name	drawn	27.10.09	Petker	
a	Origin			appd.	27.10.09	Fischer	
				norm			
				d-old			
				scale: 3:1			
				material: SEE SHEET 1			
				title: P.C.B. HOLE DRILLINGS			
				D-SUB FILTER FEMALE 90°, 25pos. 0.318inch with threaded insert and metal bracket			
				dwg no: Inventor 10		DIN-A3	
				24K1A1214		sh: 2	
				part no: SEE SHEET 1			