

REV.	DESCRIPTION	DATE
A	NEW DRAWING	7/19/2006
B	Added dimensions	4/27/2007

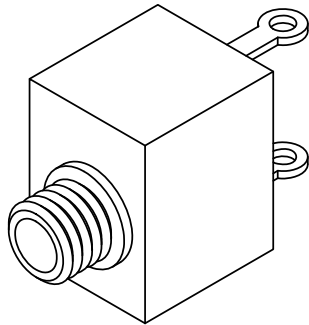

TOLERANCE:
±0.3mm UNLESS OTHERWISE
SPECIFIED

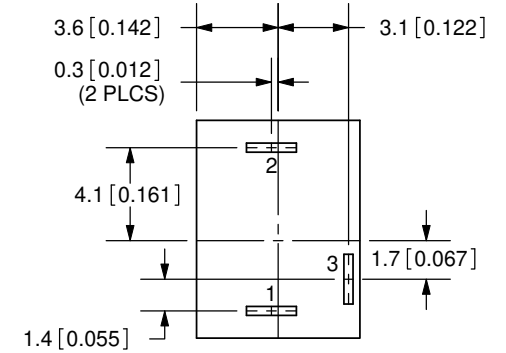
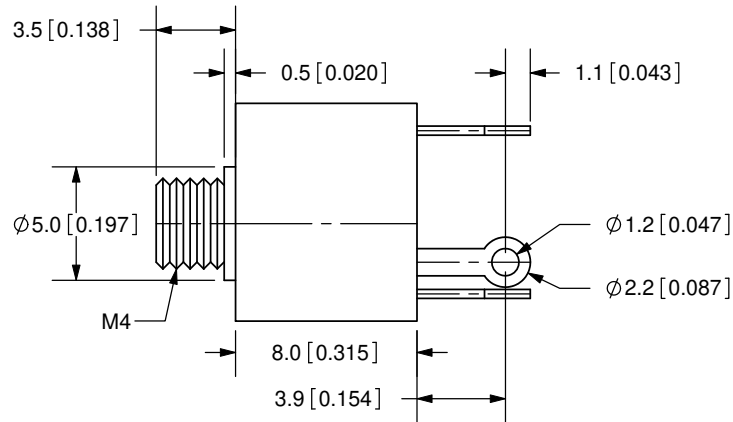
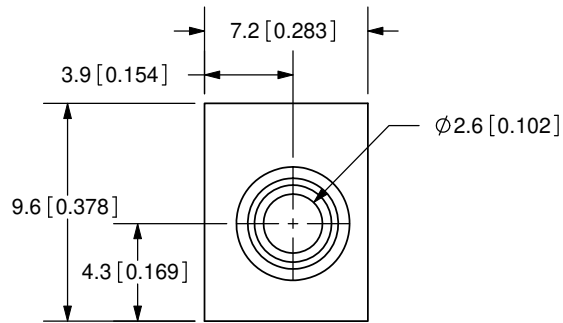

SPECIFICATIONS:
 RATING: 12V DC @ 1A
 INSULATION RESISTANCE: 50M OHMS MIN: 500V DC
 VOLTAGE WITHSTAND: 250V AC R.M.S. FOR 1 MINUTE
 LIFE: 10,000 CYCLES
 OPERATING TEMP: -10° ~ +70°C



20050 SW 112th Ave.
 Tualatin, OR 97062
 Phone: 503-612-2300
 800-275-4899
 Fax: 503-612-2383
 Website: www.cui.com

MODEL NO.	MJ-2505
SCHEMATIC	

	MATERIAL	PLATING
METAL	Brass	Nickel
TERMINAL 1	Brass	Silver
TERMINAL 2	Brass	Silver
TERMINAL 3	Brass	Silver
SPRING	Steel	
HOUSING	PC	

TITLE: 2.5mm AUDIO JACK - MONO	REV: B
PART NO. MJ-2505	UNITS: MM [INCHES]
DRAWN BY: ZRJ	APPROVED BY:
	SCALE: 3:1

PC FILE NAME:
MJ-2505

COPYRIGHT 2009 BY CUI INC.