

4 3 2 1

F

E

D

C

B

A

F

E

D

C

B

A

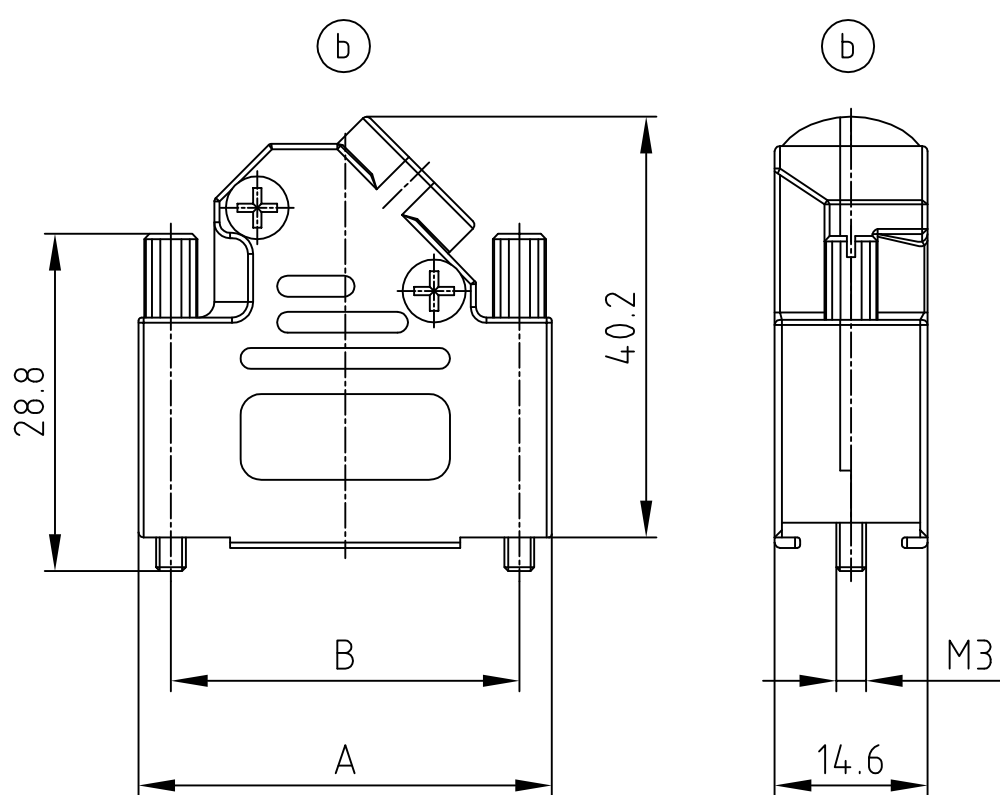
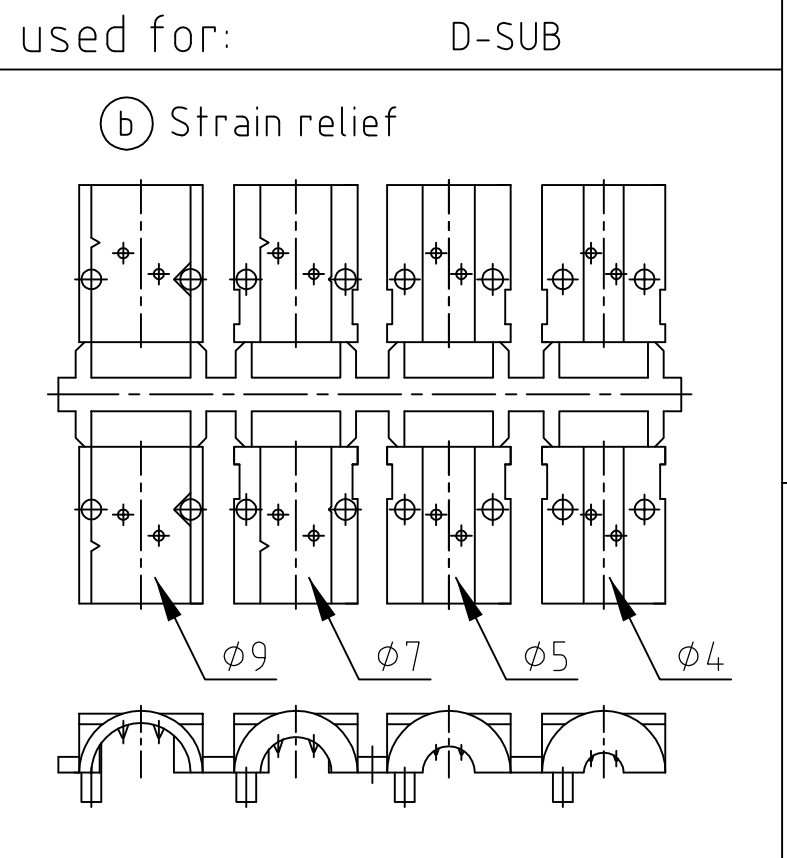

No. of pos.	A	B	Part No.
15	39.3	33.3	165X02739X
25	53.2	47.0	165X02749X
37	69.7	63.5	165X02759X

(b) TECHNICAL DATA:

1. BACKSHELL HALVES: ZINC DIE-CAST; NICKEL PLATED
2. ASSEMBLY SCREWS: STEEL; TIN PLATED
3. JACK SCREWS: STEEL; TIN PLATED
4. CABLE STRAIN RELIEF: PC
5. TEMPERATURE RANGE: -40°C to +120°C
6. ATTENUATION FACTOR: >40dB BETWEEN 30 MHz AND 2 GHz
7. ASSEMBLY INSTRUCTION SEE SHEET 2

Directive 2002/95/EC RoHS compliant

THIS DRAWING MAY NOT BE COPIED OR REPRODUCED IN ANY WAY, AND MAY NOT BE PASSED ON TO A THIRD PARTY WITHOUT WRITTEN PERMISSION. OWNERSHIP AND COPYRIGHT OF CONEC GmbH DO NOT ALTER CAD DRAWING BY HAND				tolerance			scale: 1:1		
							material: SEE NOTES		
				2007	date	name		title: METAL HOOD 15-37pos. EMI/RFI SHIELDING with side cable entry and jack screws M3	
				drawn	08.11.	Sonnenberg			
				appd.	08.11.	Mickenbecker			
				norm					
			d-old	KAT119PA		dwg no: AutoCAD		DIN-A	
			6 x b	Ä 4171	05.01.2012	Lehmen.	16K1A2174		4
			a	Original				sh:1/2	
			rev.	description	date	name	part no: SEE TABLE		



4 3 2 1

4

3

2

1

used for: D-SUB

ASSEMBLY INSTRUCTION:

Use two halves of strain relief
different sizes can be mixed

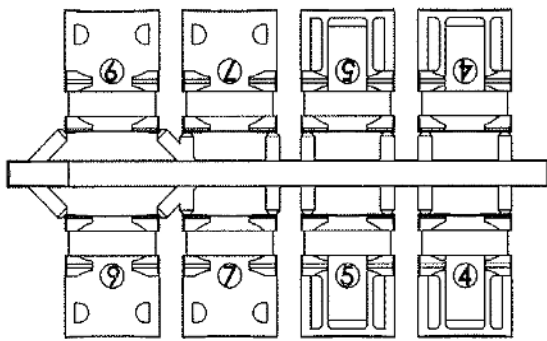

Strip cable 18mm and
shape cable to two pigtails

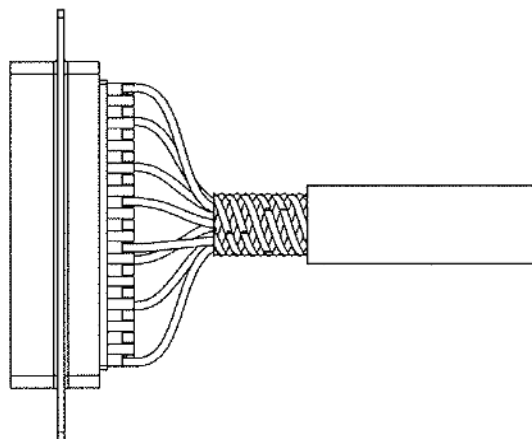

Attach the strain relief around the cable

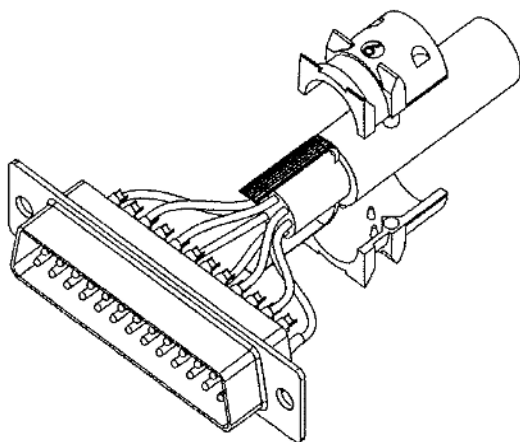

Bend cable shielding back
on outside of strain relief

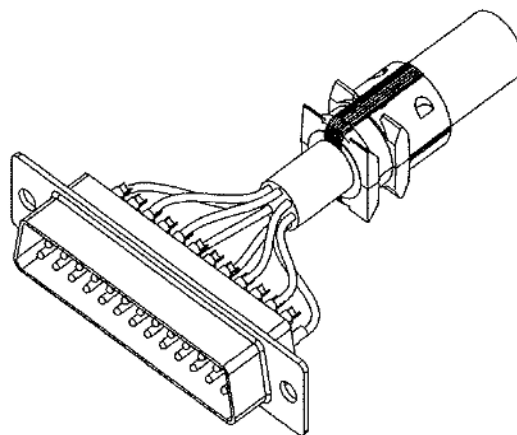

Mount connector and cable
into the backshell

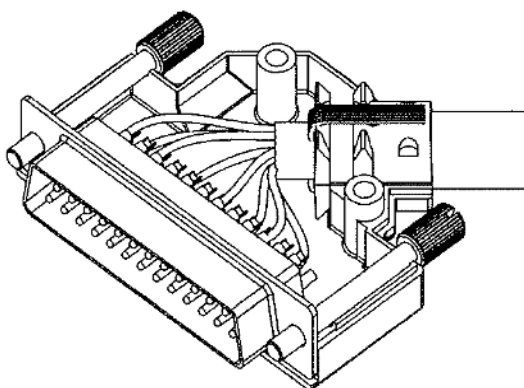

Assemble the other half
screwing force: 100-120 Ncm.

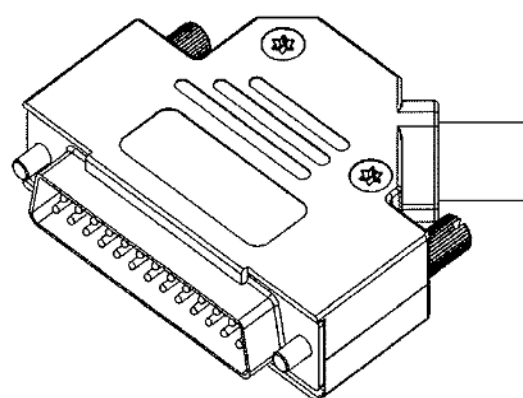

THIS DRAWING MAY NOT BE COPIED OR REPRODUCED IN ANY WAY, AND MAY NOT BE PASSED ON TO A THIRD PARTY WITHOUT WRITTEN PERMISSION.
OWNERSHIP AND COPYRIGHT OF CONEC GmbH
DO NOT ALTER CAD DRAWING BY HAND

				tolerance			scale:	
				dim. in mm			material:	
				2012	date	name	title: ASSEMBLY INSTRUCTION METAL HOOD 15-37pos. EMI/RFI SHIELDING with side cable entry and jack screws M3	
				drawn	05.01.	Lehmenkühler		
				appd.	05.01.	Fischer		
				norm				
				d-old				
a	Original						dwg no:	DIN-A 4
rev.	description	date	name				part no:	SEE SHEET 1

4

3

2

1