

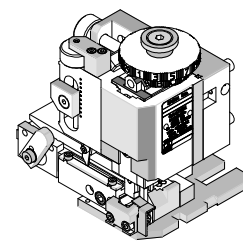

**FineAdjust  
Applicator**

**Application Tooling  
Specification Sheet**



**Order No. 63901-2100**

**FEATURES**

- Directly adapts to most automatic wire processing machines
- Quick punch removal with the push of a button for fast and easy tooling change
- Applicator designed to industry standard mounting and shut height 135.80mm (5.346")
- Quick set-up time; plus the crimp height, track and feed adjustments can be set without removing the applicator from the press
- Fine adjustment allows users to achieve target with little effort by adjusting in increments of .015mm (.0006") for conductor crimp height and .063mm (.0025") for insulation height
- Independent adjustment rings allow users to quickly adjust the conductor or insulation crimp height without affecting each other

**SCOPE**

Products: Sealed PT-Bulb Socket Positive Terminal, 0.50-0.85mm<sup>2</sup> and 18-20 AWG.

Terminal Series No.	Terminal Order No.	Wire Size		Insulation Diameter Terminal ♦		Strip Length	
		AWG	Actual mm <sup>2</sup>	mm	In.	mm	In.
35464	35464-8000	AVS-0.50 or AVSS-0.50	0.50	2.00-2.10	.079-.083	4.80-5.20	.188-.205
		20 AWG	0.50	2.00-2.10	.079-.083		
		AVS-0.85 or AVSS-0.85	0.85	2.20-2.30	.087-.091		
		18 AWG	0.80	2.20-2.30	.087-.091		

♦ To achieve optimum IPC-A620 insulation crimps, use this insulation OD range.  
 ♦♦ Overall insulation OD specification for terminal.

**DEFINITION OF TERMS**

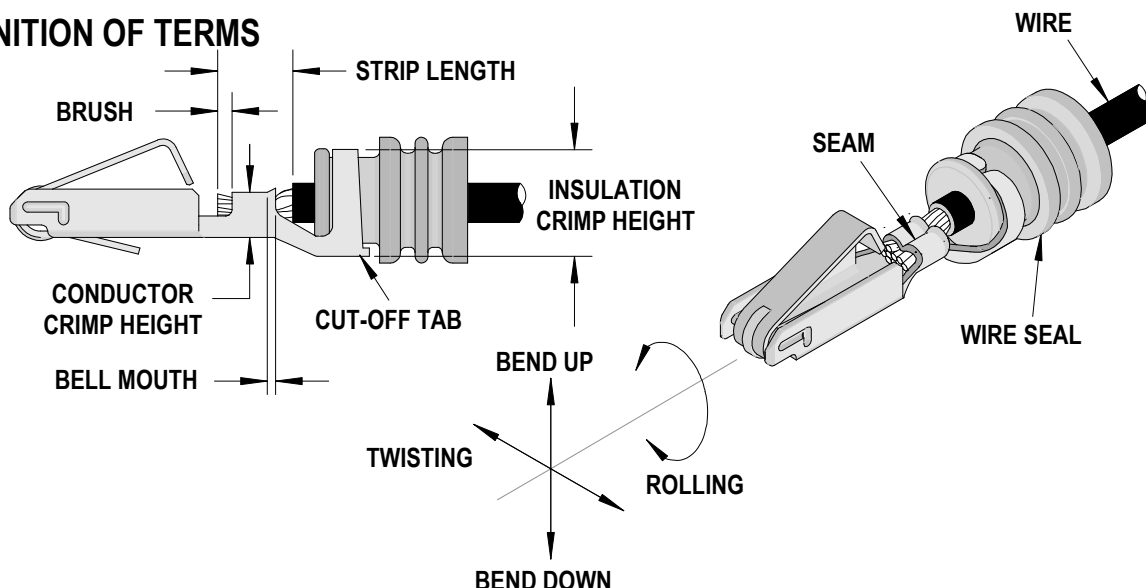

### CRIMP SPECIFICATION

Terminal Series No.	Bell mouth		Cut-off Tab Maximum		Conductor Brush	
	mm	In.	mm	In.	mm	In.
35464	0.30-0.60	.012-.024	0.50	.020	0.30-0.80	.012-.031

Terminal Series No.	Bend up	Bend down	Twist	Roll	Punch Width mm (Ref)				Seam Seam shall not be open and no wire allowed out of the crimping area
					Conductor		Insulation		
	Degree (Max)		Degree (Max)		mm	In	mm	In	
35464	3	3	3	5	2.60	.102	4.50	.177	

After crimping, the conductor profile should measure the following.

Terminal Series No.	Wire Size	Actual mm <sup>2</sup>	Conductor Crimp				Pull Force Minimum	
			Crimp Height		Crimp Width (Ref.)		N	Lb.
			mm	In.	mm	In.		
35464	AVS-0.50 AVSS-0.50	0.50	1.20-1.30	.047-.051	2.50-2.70	.098-.106	88.3	19.8
	20 AWG	0.50	1.20-1.30	.047-.051	2.50-2.70	.098-.106	88.3	19.8
	AVS-0.85 AVSS-0.85	0.85	1.30-1.40	.051-.055	2.50-2.70	.098-.106	127.5	28.7
	18 AWG	0.80	1.30-1.40	.051-.055	2.50-2.70	.098-.106	127.5	28.7

Terminal Series No.	Wire Size	Actual mm <sup>2</sup>	Wire Rear Seal		Insulation			
			Order No.	Color	Crimp Height Maximum		Crimp Width (Ref.)	
					mm	In.	mm	In.
35464	AVS-0.50 AVSS-0.50	0.50	35903-0096	Brown	4.20	.165	4.40-4.60	.173-.181
	20 AWG	0.50						
	AVS-0.85 AVSS-0.85	0.85						
	18 AWG	0.80						

Pull Force should be measured with no influence from the insulation crimp.  
The above specifications are guidelines to an optimum crimp.

**PARTS LIST**

<b>FineAdjust Applicator 63901-2100</b>				
<b>Item</b>	<b>Order No</b>	<b>Engineering No.</b>	<b>Description</b>	<b>Quantity</b>
<b>Perishable Tooling</b>				
	63901-2170	63901-2170	Tool Kit (All "Y" Items)	REF
1	63457-0049	63457-0049	Conductor Punch	1 Y
2	63445-2617	63445-2617	Conductor Anvil	1 Y
3	63454-0083	63454-0083	Insulation Punch	1 Y
4	63456-0057	63456-0057	Insulation Anvil	1 Y
5	63443-0037	63443-0037	Front Cut-Off Plunger	1 Y
6	63443-0038	63443-0038	Front Plunger Retainer	1 Y
<b>Other Components</b>				
7	63901-2101	63901-2101	Feed Guide	1
8	63443-0009	63443-0009	Front Scrap Chute	1
9	63443-0025	63443-0025	Key	1
10	63443-0086	63443-0086	Wire Stop Base	1
11	63443-0096	63443-0096	Wire Stop Target	1
12	63443-1742	63443-1742	Height Spacer	1
13	63443-2216	63443-2216	Coarse Spacer (16.00mm)	1
14	63443-2305	63443-2305	Fine Spacer (3.25mm)	1
15	63901-2102	63901-2102	Rear Cover	1
16	63700-0539	63700-0539	Cut-Off Plunger Spring	1
17	63866-9008	63866-9008	Front Plunger Striker	1
<b>Frame</b>				
18	63800-4901	63800-4901	Top	1
19	63801-3281	63801-3281	Base	1
20	63801-4650	63801-4650	Track	1
21	63801-4463	63801-4463	Feed Finger Mount	1
22	63801-4563	63801-4563	Feed Pawl	1
23	63890-0818	63890-0818	Terminal Feed Pawl Lever	1
<b>Hardware</b>				
24	N/A	N/A	M3 by 6 Long SHCS	2**
25	N/A	N/A	M3 by 6 Long FHCS	1**
26	N/A	N/A	M4 by 6 Long SHCS	2**
27	N/A	N/A	M4 by 12 Long BHCS	2**
28	N/A	N/A	M4 by 50 Long SHCS	2**
29	N/A	N/A	M5 by 12 Lg SHCS	1**
30	N/A	N/A	#10-32 by 3/8" Long Flat Point SSS	1**
31	N/A	N/A	#10-32 Hex Jam Nut	1**
** Available from an industrial supply company such as MSC (1-800-645-7270).				

### Assembly Drawing

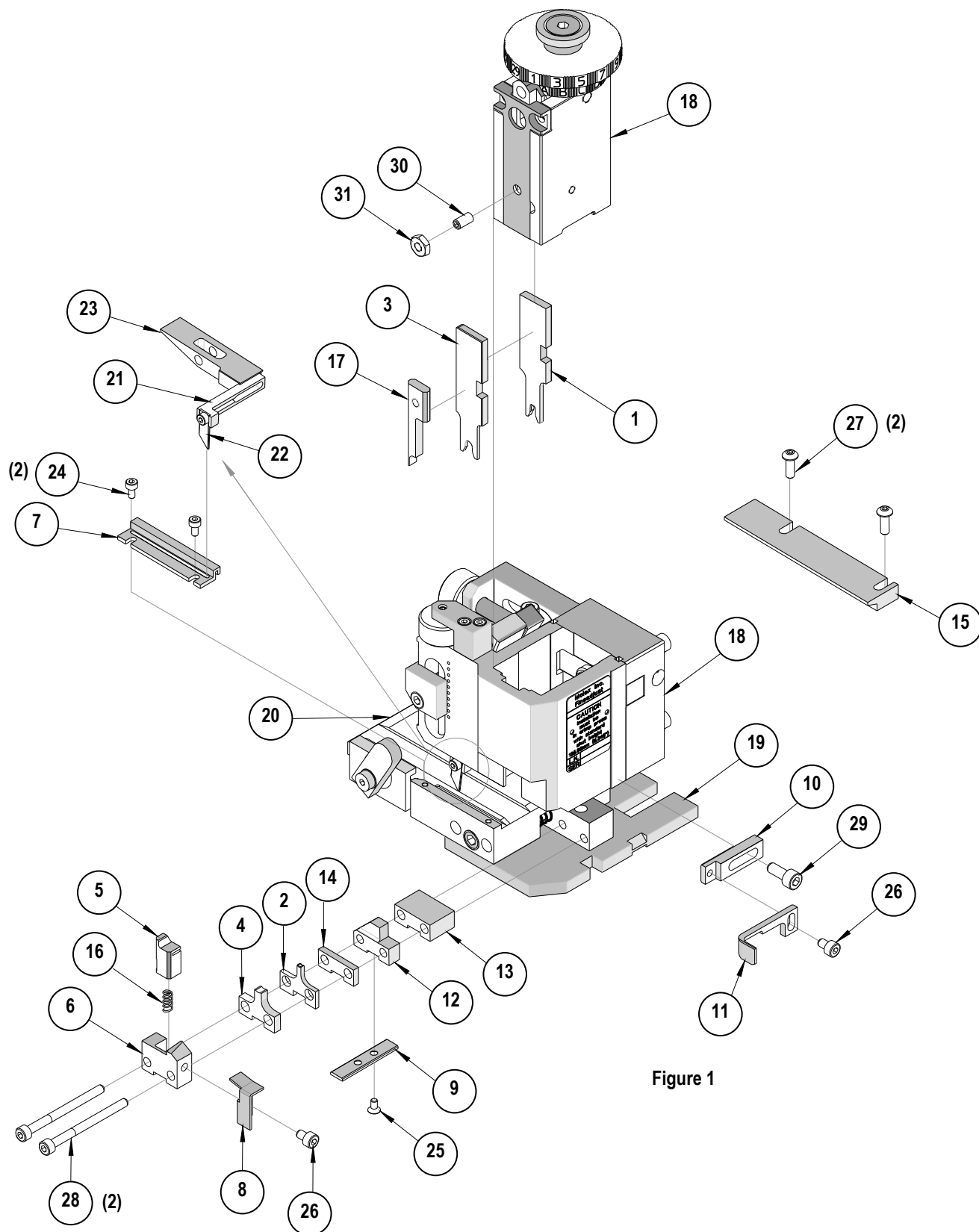

## NOTES

1. Molex recommends an extra perishable tooling kit be maintained at your facility.
2. Verify tooling alignment by manually cycling the press and Applicator before crimping under power. Check that all screws are tight.
3. Slugs, Terminals, Dirt and Oil should be kept clear of work area.
4. Wear safety glasses at all times.
5. For recommended maintenance refer to the FineAdjust Manual.

**CAUTION:** This applicator should only be used in a press with a shut height of 135.8mm (5.346"). Tooling damage could result at a lower setting.

**CAUTION:** To prevent injury never operate this Applicator without the guards supplied with the press or wire-processing machine in place. Reference the press or wire processing manufacturer's instruction manual.

**CAUTION:** Molex crimp specifications are valid only when used with Molex terminals, applicators and tooling.

<http://www.molex.com>