

NOTES:

1. COIL WOUND USING COPPER MAGNET WIRE WITH CLASS 155 SINGLE BUILD POLYURETHANE INSULATION.
2. FINISH WIRE ON COIL IS SECURED WITH BLUE DOT OF PAINT.
3. BOBBIN IS FULLY ANNEALED HYMU80 WITH PARYLENE COATING.
4. WITH A POSITIVE DC VOLTAGE APPLIED TO THE "FINISH" WIRE, THE MAGNETIC FIELD WILL ATTRACT A COMPASS NEEDLE AS SHOWN.
5. START AND FINISH WIRE TO LIE TIGHT AGAINST COIL.
6. COIL TO BE DIPPED AT LEAST 2 TIMES WITH 13-863 (CONATHANE CE-1164) TO PROVIDE A UNIFORM LAYER OF PROTECTION ON COIL WIRES.
7. SENSITIVITY MEASUREMENT IN dB re 1.0 VOLT WITH A MAGNETIC FIELD STRENGTH OF 1 A/M APPLIED TO THE COIL, LONG AXIS OF THE TELECOIL IS PARALLEL TO THE TEST MAGNETIC FIELD.
8. SOLDER SHALL NOT CONTAIN LEAD. MUST BE ROHS COMPLIANT.

ELECTRICAL CHARACTERISTICS

# OF TURNS	WIRE SIZE	INDUCTANCE @ 1KHZ (mH) ±15%	DCR@25°C (ohms) ±10%	SENSITIVE @ 1KHZ (dB) ±2dB	w/10k Ω LOAD
2500	51H HIGH RESISTANCE	41	385	-65.5	-66.0

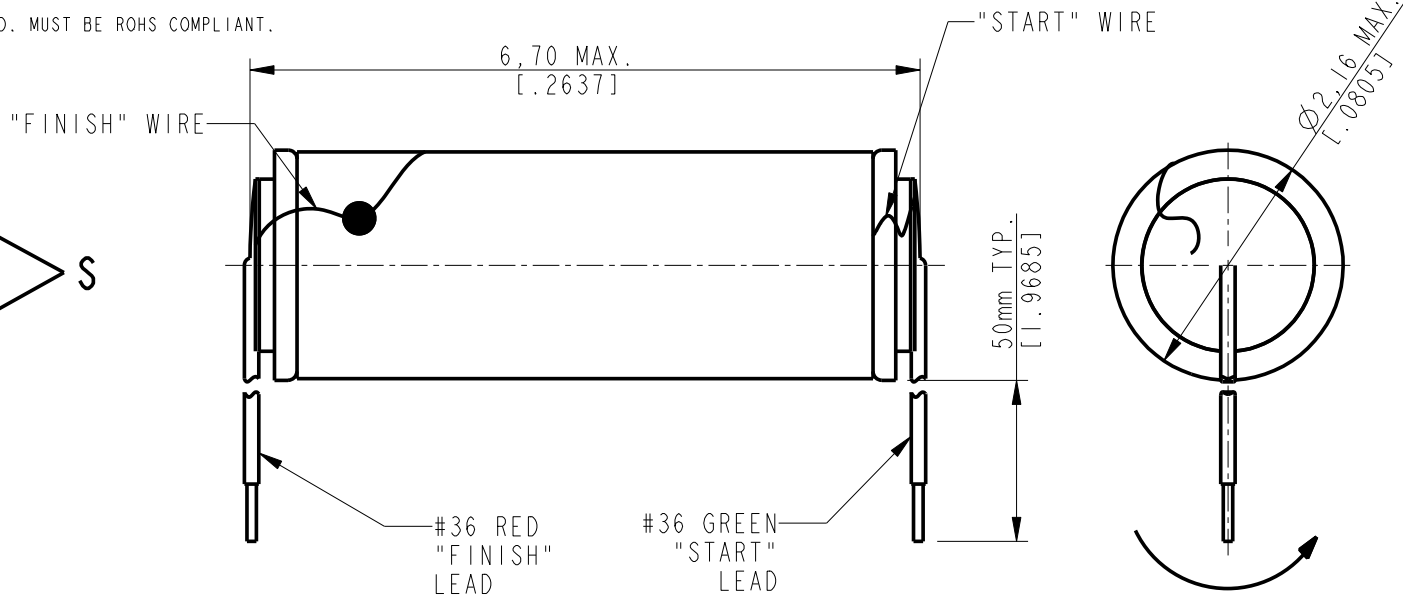
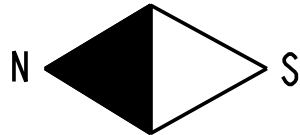

RED CONTROLLED

				SCALE: 15:1		MATERIAL:		
				FUNDAMENTAL TOLERANCE: ± 0.03 [0.001]	HEAT TREATMENT:			
				ANGLE TOLERANCE: ± 1°	FINISH:			
				MISMATCH TOLERANCE: ± 0.03 [0.001]	TITLE:			
C	C10110669	1-7-10	SDZ	DATE	NAME	FINISHED 01 STYLE BOBBIN W/2 TERMINAL PADS		
B	C10104995	11/02/06	BCS	DESIGNED	01/10/06			BCS
A	C10103768	01/12/06	BCS	CHECKED	01/10/06			BCS
REV.	CHANGE #	DATE	NAME	RELEASED	01/10/06			TDS
PROPRIETARY NOTE: THIS DOCUMENT CONTAINS INFORMATION WHICH IS THE PROPRIETARY PROPERTY OF KNOWLES ELECTRONICS, LLC. OR ITS AFFILIATED ENTITIES. IT IS ISSUED IN STRICT CONFIDENCE AND SHALL NOT BE REPRODUCED, COPIED, USED, OR DISCLOSED TO ANY THIRD PARTY PARTIALLY OR WHOLLY IN ANY MANNER WITHOUT PRIOR WRITTEN PERMISSION OF, AND MUST BE RETURNED UPON REQUEST BY, KNOWLES ELECTRONICS, LLC.						RELEASED LEVEL: Active	REVISION: C	
						DRAWING NUMBER: 5100-253584	SHEETS: 1 of 1	