

**PI6CB33401**

**Very Low Power 4-Output PCIe Clock Buffer With On-Chip Termination**

**Features**

- 3.3V supply voltage
- HCSL input: 100MHz, also support 50MHz, 125MHz or 133.33MHz via SMBus
- 4 differential low power HCSL outputs with on-chip termination
- Default  $Z_{OUT} = 100\Omega$
- Spread spectrum tolerant
- Individual output enable
- Programmable Slew rate and output amplitude for each output
- Differential outputs blocked until PLL is locked
- Strapping pins or SMBus for configuration
- Differential output-to-output skew <50ps
- Very low jitter outputs
  - Differential cycle-to-cycle jitter <50ps
  - PCIe Gen1/Gen2/Gen3/Gen4/Gen5 CC compliant
  - PCIe Gen 2 and 3 SRiS and SRnS compliant
- Totally Lead-Free & Fully RoHS Compliant (Notes 1 & 2)
- Halogen and Antimony Free. "Green" Device (Note 3)
- For automotive applications requiring specific change control (i.e. parts qualified to AEC-Q100/101/104/200, PPAP capable, and manufactured in IATF 16949 certified facilities), please [contact us](https://www.diodes.com/contact-us) or your local Diodes representative. <https://www.diodes.com/quality/product-definitions/>
- Packaging (Pb-free & Green):
  - 32-lead 5x5mm TQFN

**Description**

The PI6CB33401 is a 4-output very low power PCIe Gen1/Gen2/Gen3/Gen4/Gen5 clock buffer. It takes a reference input to fanout four 100MHz low power differential HCSL outputs with on-chip terminations. The on-chip termination can save 16 external resistors and make layout easier. Individual OE pin for each output provides easier power management.

It uses Diodes proprietary PLL design to achieve very low jitter that meets PCIe Gen1/Gen2/Gen3/Gen4/Gen5 requirements. Other than PCIe 100MHz support, this device also support Ethernet application with 50MHz, 125MHz and 133.33MHz via SMBus. It provides various options such as different slew rate and amplitude through SMBUS so that users can configure the device easily to get the optimized performance for their individual boards.

**Block Diagram**

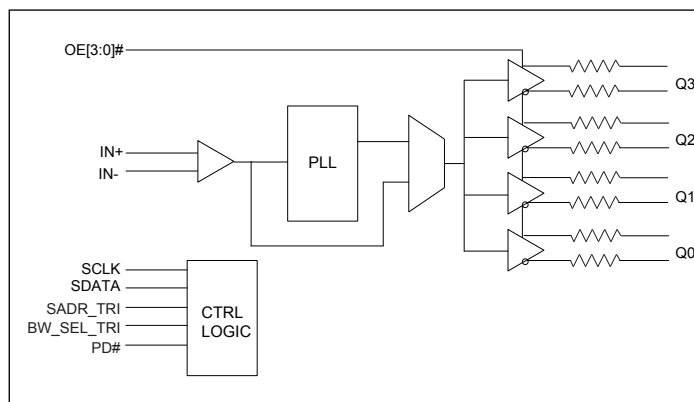

**Notes:**

1. No purposely added lead. Fully EU Directive 2002/95/EC (RoHS), 2011/65/EU (RoHS 2) & 2015/863/EU (RoHS 3) compliant.
2. See <https://www.diodes.com/quality/lead-free/> for more information about Diodes Incorporated's definitions of Halogen- and Antimony-free, "Green" and Lead-free.
3. Halogen- and Antimony-free "Green" products are defined as those which contain <900ppm bromine, <900ppm chlorine (<1500ppm total Br + Cl) and <1000ppm antimony compounds.

## Pin Configuration

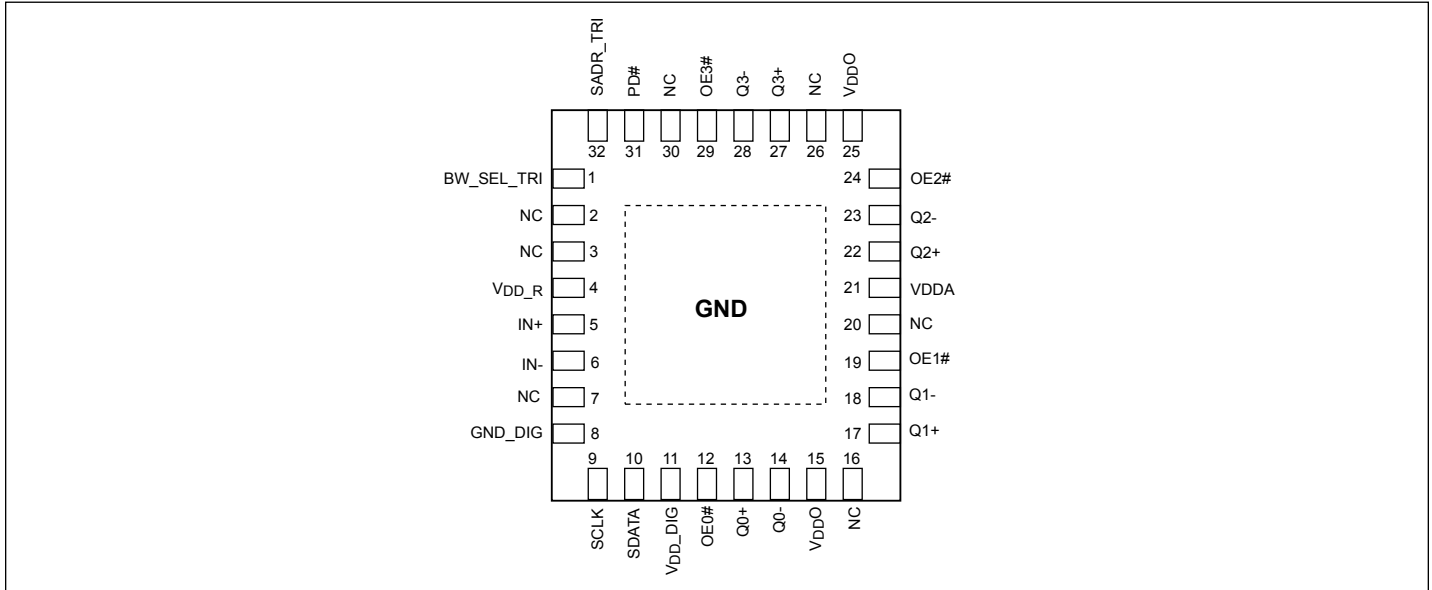

## Pin Description

Pin Number	Pin Name	Type		Description
1	BW_SEL_TRI	Input	Tri-level	Latch to select low loop bandwidth, bypass PLL, and high loop bandwidth. This pin has both internal pull-up and pull-down
2	NC			Internal connected for feedback loop. Do not connect this pin
3	NC			Internal connected for feedback loop. Do not connect this pin
4	VDD_R	Power		Power supply for input differential buffers
5	IN+	Input		Differential true clock input
6	IN-	Input		Differential complementary clock input
7	NC			Do not connect this pin
8	GND_DIG	Power		Ground for digital circuitry
9	SCLK	Input	CMOS	SMBUS clock input, 3.3V tolerant
10	SDATA	Input/ Output	CMOS	SMBUS Data line, 3.3V tolerant
11	VDD_DIG	Power		Power supply for digital circuitry, nominal 3.3V
12	OE0#	Input	CMOS	Active low input for enabling Q0 pair. This pin has an internal pull-down. 1 =disable outputs, 0 = enable outputs
13	Q0+	Output	HCSL	Differential true clock output
14	Q0-	Output	HCSL	Differential complementary clock output
15, 25	VDDO	Power		Power supply for differential outputs
16	NC			Do not connect this pin
17	Q1+	Output	HCSL	Differential true clock output

**Pin Description Cont.**

Pin Number	Pin Name	Type		Description
18	Q1-	Output	HCSL	Differential complementary clock output
19	OE1#	Input	CMOS	Active low input for enabling Q1 pair. This pin has an internal pull-down. 1 =disable outputs, 0 = enable outputs
20	NC			Do not connect this pin
21	V <sub>D</sub> DA	Power		Power supply for analog circuitry
22	Q2+	Output	HCSL	Differential true clock output
23	Q2-	Output	HCSL	Differential complementary clock output
24	OE2#	Input	CMOS	Active low input for enabling Q2 pair. This pin has an internal pull-down. 1 =disable outputs, 0 = enable outputs
26	NC			Do not connect this pin
27	Q3+	Output	HCSL	Differential true clock output
28	Q3-	Output	HCSL	Differential complementary clock output
29	OE3#	Input	CMOS	Active low input for enabling Q3 pair. This pin has an internal pull-down. 1 =disable outputs, 0 = enable outputs
30	NC			Do not connect this pin
31	PD#	Input	CMOS	Input notifies device to sample latched inputs and start up on first high assertion. Low enters Power Down Mode, subsequent high assertions exit Power Down Mode. This pin has internal pull-up resistor.
32	SADR_TRI	Input	Tri-level	Latch to select SMBus Address. This pin has an internal pull-down
	EPAD	Power		Connect to Ground

### SMBus Address Selection Table

	SADR	Address	+Read/Write Bit
State of SADR on first application of PD#	0	1101011	X
	M	1101100	X
	1	1101101	X

### Power Management Table

PD#	IN	SMBus OE bit	OEn#	Qn+	Qn-	PLL Status
0	X	X	X	Low <sup>(2)</sup>	Low <sup>(2)</sup>	Off
1	Running	0	X	Low <sup>(2)</sup>	Low <sup>(2)</sup>	On <sup>(1)</sup>
1	Running	1	0	Running	Running	On <sup>(1)</sup>
1	Running	1	1	Low <sup>(2)</sup>	Low <sup>(2)</sup>	On <sup>(1)</sup>

**Note:**

1. If PLL Bypass mode is selected, the PLL will be off and outputs will be running.
2. The output state is set by B11[1:0] (Low/Low default)

### PLL Operating Mode Select Table

BW_SEL_TRI	Operating Mode	Byte1 [7:6] Readback	Byte1 [4:3] Control
0	PLL with low Bandwidth	00	00
M	PLL Bypass	01	01
1	PLL with high Bandwidth	11	11

### Frequency Select Table

Freq. Select Byte 3 [4:3]	IN (MHz)	Qn (MHz)
00 (default)	100	100
01	50	50
10	125	125
11	133.33	133.33

## Maximum Ratings

(Above which useful life may be impaired. For user guidelines, not tested.)

Storage Temperature.....	-65°C to +150°C
Supply Voltage to Ground Potential, $V_{DDxx}$ .....	-0.5V to +4.6V
Input Voltage .....	-0.5V to $V_{DD}+0.5V$ , not exceed 4.6V
SMBus, Input High Voltage .....	3.6V
ESD Protection (HBM) .....	2000 V
Junction Temperature .....	125 °C max

**Note:**

Stresses greater than those listed under MAXIMUM RATINGS may cause permanent damage to the device. This is a stress rating only and functional operation of the device at these or any other conditions above those indicated in the operational sections of this specification is not implied. Exposure to absolute maximum rating conditions for extended periods may affect reliability.

## Operating Conditions

Temperature =  $T_A$ ; Supply voltages per normal operation conditions; See test circuits for the load conditions

Symbol	Parameters	Conditions	Min.	Typ.	Max.	Units
$V_{DDO}$ , $V_{DDA}$ , $V_{DD\_R}$ , $V_{DD\_DIG}$	Power Supply Voltage		3.135	3.3	3.465	V
$I_{DDA}$	Analog Power Supply Current	$V_{DDA}$ , PLL mode, All outputs active @100MHz		21	25	mA
$I_{DD\_DIG}$	Digital Power Supply Current	$V_{DD\_DIG}$ , All outputs active @100MHz		0.1	1	mA
$I_{DDO+R}$	Power Supply Current for Inputs and Outputs <sup>(2)</sup>	$V_{DDO} + V_{DD\_R}$ , PLL mode, All outputs active @100MHz		48	54	mA
$I_{DDA\_PD}$	Analog Power Supply Power Down <sup>(1)</sup> Current	$V_{DDA}$ , PLL mode, All outputs LOW/LOW		0.5	1	mA
$I_{DD\_DIG\_PD}$	Power Supply Power Down <sup>(1)</sup> Current	$V_{DD\_DIG}$ , All outputs LOW/LOW		0.1	1	mA
$I_{DDO\_R\_PD}$	Power Supply Current Power Down <sup>(1)</sup> for Inputs and Outputs	$V_{DDO}$ , $V_{DD\_R}$ All outputs LOW/LOW		1	2	mA
$T_A$	Ambient Temperature	Industrial grade	-40		85	°C

**Note:**

1. Input clock is not running.
2. Output drive 5 inch trace.

## Input Electrical Characteristics

Symbol	Parameters	Conditions	Min.	Typ.	Max.	Units
$R_{pu}$	Internal pull up resistance			120		K $\Omega$
$R_{dn}$	Internal pull down resistance			120		K $\Omega$
$L_{PIN}$	Pin inductance				7	nH

### SMBus Electrical Characteristics

Temperature =  $T_A$ ; Supply voltages per normal operation conditions; See test circuits for the load conditions

Symbol	Parameters	Conditions	Min.	Typ.	Max.	Units
$V_{DDSMB}$	Nominal bus voltage		2.7		3.6	V
$V_{IHSMB}$	SMBus Input High Voltage	SMBus, $V_{DDSMB} = 3.3V$	2.1		3.6	V
		SMBus, $V_{DDSMB} < 3.3V$	0.65 $V_{DDSMB}$			
$V_{ILSMB}$	SMBus Input Low Voltage	SMBus, $V_{DDSMB} = 3.3V$			0.8	V
		SMBus, $V_{DDSMB} < 3.3V$			0.8	
$I_{SMBSINK}$	SMBus sink current	SMBus, at $V_{OLSMB}$	4			mA
$V_{OLSMB}$	SMBus Output Low Voltage	SMBus, at $I_{SMBSINK}$			0.4	V
$f_{MAXSMB}$	SMBus operating frequency	Maximum frequency			500	kHz
$t_{RMSB}$	SMBus rise time	(Max $V_{IL} - 0.15$ ) to (Min $V_{IH} + 0.15$ )			1000	ns
$t_{FMSB}$	SMBus fall time	(Min $V_{IH} + 0.15$ ) to (Max $V_{IL} - 0.15$ )			300	ns

### LVC MOS DC Electrical Characteristics

Temperature =  $T_A$ ; Supply voltages per normal operation conditions; See test circuits for the load conditions

Symbol	Parameters	Conditions	Min.	Typ.	Max.	Units
$V_{IH}$	Input High Voltage	Single-ended inputs, except SMBus	0.75 $V_{DD}$		$V_{DD} + 0.3$	V
$V_{IM}$	Input Mid Voltage	SADR_TRI, BW_SEL_TRI	$0.4V_{DD}$	$0.5V_{DD}$	$0.6V_{DD}$	V
$V_{IL}$	Input Low Voltage	Single-ended inputs, except SMBus	-0.3		$0.25V_{DD}$	V
$I_{IH}$	Input High Current	Single-ended inputs, $V_{IN} = V_{DD}$			5	$\mu A$
$I_{IL}$	Input Low Current	Single-ended inputs, $V_{IN} = 0V$	-5			$\mu A$
$I_{IH}$	Input High Current	Single-ended inputs with pull up / pull down resistor, $V_{IN} = V_{DD}$			50	$\mu A$
$I_{IL}$	Input Low Current	Single-ended inputs with pull up / pull down resistor, $V_{IN} = 0V$	-50			$\mu A$
$C_{IN}$	Input Capacitance		1.5		5	pF

### LVC MOS AC Electrical Characteristics

Temperature = T<sub>A</sub>; Supply voltages per normal operation conditions; See test circuits for the load conditions

Symbol	Parameters	Conditions	Min.	Typ.	Max.	Units
t <sub>OE</sub> LAT	Output enable latency	Q start after OE# assertion Q stop after OE# deassertion	1		3	clocks
t <sub>PD</sub> LAT	PD# de-assertion	Differential outputs enable after PD# de-assertion		20	300	us

### HCSL Input Characteristics<sup>(1)</sup>

Temperature = T<sub>A</sub>; Supply voltages per normal operation conditions; See test circuits for the load conditions

Symbol	Parameters	Conditions	Min.	Typ.	Max.	Units
V <sub>IHDIF</sub>	Diff. Input High Voltage <sup>(3)</sup>	IN+, IN-, single-end measurement	600	800	1150	mV
V <sub>ILDIF</sub>	Diff. Input Low Voltage <sup>(3)</sup>	IN+, IN-, single-end measurement	-300	0	300	mV
V <sub>COM</sub>	Diff. Input Common Mode Voltage		150		900	mV
V <sub>SWING</sub>	Diff. Input Swing Voltage	Peak to peak value (V <sub>IHDIF</sub> - V <sub>ILDIF</sub> )	300		2900	mV
f <sub>INBP</sub>	Input Frequency	PLL Bypass mode	1		200	MHz
f <sub>IN100</sub>	Input Frequency	100MHz PLL	99.9	100	100.1	MHz
f <sub>IN133</sub>	Input Frequency	133MHz PLL	133.2	133.33	133.46	MHz
f <sub>IN125</sub>	Input Frequency	125MHz PLL	124.87	125	125.12	MHz
f <sub>IN50</sub>	Input Frequency	50MHz PLL	49.95	50	50.05	MHz
f <sub>MODI-PCIE</sub>	Input SS Modulation Freq. PCIe	Allowable frequency for PCIe applications (Triangular Modulation)	30		33	kHz
f <sub>MODIN-non-PCIE</sub>	Input SS Modulation Freq. non-PCIE	Allowable frequency for non-PCIE applications (Triangular Modulation)	0		46	kHz
t <sub>STAB</sub>	Clock stabilization	From V <sub>DD</sub> Power-Up and after input clock stabilization or de-assertion of PD# to 1st clock		0.75	1.0	ms
t <sub>RF</sub>	Diff. Input Slew Rate <sup>(2)</sup>	Measured differentially	0.4			V/ns
I <sub>IN</sub>	Diff. Input Leakage Current	V <sub>IN</sub> = V <sub>DD</sub> , V <sub>IN</sub> = GND	-5	0.01	5	uA
t <sub>DC</sub>	Diff. Input Duty Cycle	Measured differentially	45		55	%
t <sub>jC-c</sub>	Diff. Input Cycle to cycle jitter	Measured differentially			125	ps

**Note:**

1. Guaranteed by design and characterization, not 100% tested in production
2. Slew rate measured through +/-75mV window centered around differential zero
3. The device can be driven by a single-ended clock by driving the true clock and biasing the complement clock input to the V<sub>bias</sub>, where V<sub>bias</sub> is (V<sub>IH</sub>-V<sub>IL</sub>)/2

## HCSL Output Characteristics

Temperature =  $T_A$ ; Supply voltages per normal operation conditions; See test circuits for the load conditions

Symbol	Parameters	Condition	Min.	Typ.	Max.	Units
$V_{OH}$	Output Voltage High <sup>(1)</sup>	Statistical measurement on single-ended signal using oscilloscope math function	660	784	850	mV
$V_{OL}$	Output Voltage Low <sup>(1)</sup>		-150		150	mV
$V_{OMAX}$	Output Voltage Maximum <sup>(1)</sup>	Measurement on single ended signal using absolute value		816	1150	mV
$V_{OMIN}$	Output Voltage Minimum <sup>(1)</sup>		-300	-42		mV
$V_{OC}$	Output Cross Voltage <sup>(1,2,4)</sup>		250	430	550	mV
$DV_{OC}$	$V_{OC}$ Magnitude Change <sup>(1,2,5)</sup>			12	140	mV

### Note:

1. At default SMBUS amplitude settings
2. Guaranteed by design and characterization, not 100% tested in production
3. Measured from differential waveform
4. This one is defined as voltage where  $Q+ = Q-$  measured on a component test board and only applied to the differential rising edge
5. The total variation of all  $V_{cross}$  measurements in any particular system. This is a subset of  $V_{cross\_min/max}$  allowed.

## HCSL Output AC Characteristics

Temperature =  $T_A$ ; Supply voltages per normal operation conditions; See test circuits for the load conditions

Symbol	Parameters	Condition	Min.	Typ.	Max.	Units
$f_{OUT}$	Output Frequency		50	100	133.33	MHz
BW	PLL bandwidth <sup>(1,8)</sup>	-3dB point in High Bandwidth Mode	1.3	3.2	3.6	MHz
		-3dB point in Low Bandwidth Mode	0.7	1.7	1.9	MHz
$t_{jpeak}$	PLL Jitter Peaking <sup>(1)</sup>	Peak pass band gain		0.8	2	dB
$t_{RF}$	Slew rate <sup>(1,2,3)</sup>	Scope averaging on fast setting	2.5	3.2	4.0	V/ns
		Scope averaging on slow setting	2.2	3.0	3.7	V/ns
$D_{tRF}$	Slew rate matching <sup>(1,2,4)</sup>	Scope averaging on		7	15	%
$t_{SKEW}$	Output Skew <sup>(1,2)</sup>	Averaging on, $V_T = 50\%$		21	50	ps
$t_{PDELAY}$	Propagation delay	PLL Bypass mode, $V_T = 50\%$	2000	2500	3000	ps
		PLL mode, $V_T = 50\%$	-200	90	200	ps
$t_{DC}$	Duty Cycle <sup>(1,2)</sup>	Measured differentially, PLL Mode	45	50	55	%
$t_{DCD}$	Duty Cycle Distortion <sup>(1,7)</sup>	Measured differentially, PLL Bypass Mode at 100MHz	-3.5	0	3.5	%
$t_{DCD}$	Duty Cycle Distortion <sup>(1,7)</sup>	Measured differentially, SE input, PLL Bypass Mode at 100MHz	-10	0	10	%
$t_{j-c-c}$	Cycle to cycle jitter <sup>(1,2)</sup>	PLL mode		14	50	ps
		Additive jitter, Bypass mode		0.1	1	ps



**PI6CB33401**

### HCSL Output AC Characteristics (jitter)

Symbol	Parameters	Condition	Min.	Typ.	Max.	Spec Limit	Units
t <sub>JPHASEPLL</sub>	Integrated phase jitter PLL mode (RMS) <sup>(1,5)</sup>	PCIe Gen 1 <sup>(6)</sup>		25	35	86	ps(p-p)
		PCIe Gen 2 Low Band, 10kHz < f < 1.5MHz		0.6	0.8	3	ps
		PCIe Gen 2 High Band, 1.5MHz < f < Nyquist (50MHz)		0.7	1.2	3.1	ps
		PCIe Gen 3 (PLL BW of 2-4 or 2-5MHz, CDR =10MHz)		0.25	0.4	1	ps
		PCIe Gen 4 (PLL BW of 2-4 or 2-5MHz, CDR =10MHz)		0.25	0.4	0.5	ps
		PCIe Gen 5 (PLL BW of 500k to 1.8MHz. CDR =20MHz) <sup>(11)</sup>		0.07	0.12	0.15	ps
		125MHz, 1.5MHz to 20MHz, -20dB/decade Rollover < 1.5MHz, -40dB/decade rolloff > 10MHz		0.15	0.3		ps
		133.33MHz		0.15	0.3		ps
t <sub>JPHASEA</sub>	Additive Integrated phase jitter (RMS) <sup>(1,5,10)</sup>	PCIe Gen 1		0.01	0.05		ps(p-p)
		PCIe Gen 2 Low Band, 10kHz < f < 1.5MHz		0.01	0.05		ps
		PCIe Gen 2 High Band, 1.5MHz < f < Nyquist (50MHz)		0.01	0.05		ps
		PCIe Gen 3 (PLL BW of 2-4 or 2-5MHz, CDR =10MHz)		0.01	0.05		ps
		PCIe Gen 4 (PLL BW of 2-4 or 2-5MHz, CDR =10MHz)		0.01	0.05		ps
		PCIe Gen 5 (PLL BW of 500k to 1.8MHz. CDR =20MHz) <sup>(11)</sup>		0.01	0.05		ps
		125MHz, 1.5MHz to 20MHz, -20dB/decade Rollover < 1.5MHz, -40dB/decade rolloff > 10MHz		0.01	0.05		ps
		133.33MHz		0.01	0.05		ps
		156.25MHz 12k to 20MHz		0.01	0.05		ps

**Note:**

1. Guaranteed by design and characterization, not 100% tested in production
2. Measured from differential waveform
3. Slew rate is measured through the Vswing voltage range centered around differential 0V, within +/-150mV window
4. Slew rate matching is measured through +/-75mV window centered around differential zero
5. See <http://www.pcisig.com> for complete specs
6. Sample size of at least 100k cycles. This can be extrapolated to 108ps pk-pk @ 1M cycles for a BER of 10<sup>-12</sup>
7. Duty cycle distortion is the difference in duty cycle between the output and input clock when the device is operated in the PLL bypass mode
8. The Min and Max values of each BW setting track each other, low BW max will never occur with high BW min
9. Applies to all differential outputs
10. For additive jitter RMS value is calculated by the following equation = SQRT [(total jitter)<sup>2</sup> - (input jitter)<sup>2</sup>]
11. PCIe Gen 5 v0.9 specification

## SMBus Serial Data Interface

PI6CB33401 is a slave only device that supports block read and block write protocol using a single 7-bit address and read/write bit as shown below.

Read and write block transfers can be stopped after any complete byte transfer.

### Address Assignment

A6	A5	A4	A3	A2	A1	A0	R/W
1	1	0	1	See SBMus Address Selection table			1/0

Note: SMBus address is latched on SADR pin

### How to Write

1 bit	7 bits	1 bit	1 bit	8 bits	1 bit	8 bits	1 bit	8 bits	1 bit		8 bits	1 bit	1 bit
Start bit	Add.	W(0)	Ack	Beginning Byte location = N	Ack	Data Byte count = X	Ack	Beginning Data Byte (N)	Ack	.....	Data Byte (N+X-1)	Ack	Stop bit

### How to Read

1 bit	7 bits	1 bit	1 bit	8 bits	1 bit	1 bit	7 bits	1 bit	1 bit	8 bits	1 bit	8 bits	1 bit
Start bit	Address	W(0)	Ack	Beginning Byte location = N	Ack	Repeat Start bit	Address	R(1)	Ack	Data Byte count = X	Ack	Beginning Data Byte (N)	Ack

											8 bits	1 bit	1 bit
.....											Data Byte (N+X-1)	NAck	Stop bit

### Byte 0: Output Enable Register

Bit	Control Function	Description	Type	Power Up Condition	0	1
7	Reserved			0	See B11[1:0]	Pin control
6	Q3_OE	Q3 output enable	RW	1		
5	Reserved			0		
4	Q2_OE	Q2 output enable	RW	1		
3	Q1_OE	Q1 output enable	RW	1		
2	Reserved			0		
1	Q0_OE	Q0 output enable	RW	1		
0	Reserved			0		

**Note:**

1. A low on these bits will override the OE# pins and force the differential outputs to the state indicated by B11[1:0] (Low/Low default)

### Byte 1: PLL Operating Mode and Output Amplitude Control Register

Bit	Control Function	Description	Type	Power Up Condition	0	1
7	PLLMODERB1	PLL Mode Readback Bit1	R	Latch	See PLL Operating Mode Table	
6	PLLMODERB0	PLL Mode Readback Bit0	R	Latch		
5	PLLMODE_SWCTR	Enable SW control of PLL Mode	RW	0	Values in B1[7:6] set PLL Mode	Values in B1[4:3] set PLL Mode
4	PLLMODE1	PLL Mode control Bit1	RW <sup>(1)</sup>	0	See PLL Operating Mode Table	
3	PLLMODE0	PLL Mode control Bit0	RW <sup>(1)</sup>	0		
2	Reserved			1		
1	Amplitude1	Control output amplitude	RW	1	'00' = 0.6V, '01' = 0.68V, '10' = 0.75V, '11' = 0.85V	
0	Amplitude0		RW	0		

**Note:**

1. B1[5] must be set to a 1 for these bits to have any effect on the part

**PI6CB33401**

**Byte 2: Differential Output Slew Rate Control Register**

Bit	Control Function	Description	Type	Power Up Condition	0	1
7	Reserved			1		
6	SLEWRATECTR_Q3	Control slew rate of Q3	RW	1	Slow setting	Fast setting
5	Reserved			1		
4	SLEWRATECTR_Q2	Control slew rate of Q2	RW	1	Slow setting	Fast setting
3	SLEWRATECTR_Q1	Control slew rate of Q1	RW	1	Slow setting	Fast setting
2	Reserved			1		
1	SLEWRATECTR_Q0	Control slew rate of Q0	RW	1	Slow setting	Fast setting
0	Reserved			1		

**Byte 3: Frequency Select Control Register**

Bit	Control Function	Description	Type	Power Up Condition	0	1
7	Reserved			1		
6	Reserved			1		
5	FREQ_SEL_EN	Enable SW selection of frequency	RW	0	SW Freq. selection disabled	SW Freq. selection enabled
4	FSEL1	Freq. Select Bit 1	RW <sup>(1)</sup>	0	See Frequency Select Table	
3	FSEL0	Freq. Select Bit 0	RW <sup>(1)</sup>	0		
2	Reserved			1		
1	Reserved			1		
0	SLEWRATESEL_FB	Adjust Slew Rate of Feedback signal	RW	1	Slow setting	Fast setting

**Note:**

1. B3[5] must be set to a 1 for these bits to have any effect on the part

**Byte 4: Reserved**

Bit	Control Function	Description	Type	Power Up Condition	0	1
7:0	Reserved			1		

**PI6CB33401**

**Byte 5: Revision and Vendor ID Register**

Bit	Control Function	Description	Type	Power Up Condition	0	1
7	RID3	Revision ID	R	0	rev = 0000	
6	RID2		R	0		
5	RID1		R	0		
4	RID0		R	0		
3	PVID3	Vendor ID	R	0	Diodes = 0011	
2	PVID2		R	0		
1	PVID1		R	1		
0	PVID0		R	1		

**Byte 6: Device Type/Device ID Register**

Bit	Control Function	Description	Type	Power Up Condition	0	1
7	DTYPE1	Device type	RW	0	'00' = CG, '01' = ZDB, '10' = Reserve, '11' = ZDB	
6	DTYPE0		RW	1		
5	DID5	Device ID	RW	0	000100 binary, 04Hex	
4	DID4		RW	0		
3	DID3		RW	0		
2	DID2		RW	1		
1	DID1		RW	0		
0	DID0		RW	0		

**Byte 7: Reserved**

Bit	Control Function	Description	Type	Power Up Condition	0	1
7:0	Reserved			0x08		

**Byte 8 and 9: Reserved**

Bit	Control Function	Description	Type	Power Up Condition	0	1
7:0	Reserved			B8 = 0x36 B9 = 0x00		

**PI6CB33401**

**Byte 10: PD Restore**

Bit	Control Function	Description	Type	Power Up Condition	0	1
7	Reserved		RW	1		
6	PD Restore	PD Restore to default configuration	RW	1	Clear PD Config	Keep PD Config
5:0	Reserved		R	0		

**Byte 11: Stop Control**

Bit	Control Function	Description	Type	Power Up Condition	0	1
7	FB_imp[1]	Feedback Zout	RW	1	00=Reserved	10=100 DIF Zout
6	FB_imp[0]		RW	0	01=85 DIF Zout	11 = Reserved
5:2	Reserved			0		
1	STP1	True/ Compliment DIF Output Disable Sate	RW	0	00= Low/Low	10= High/Low
0	STP0		RW	0	01= HiZ/HiZ	11= Low/High

**Byte 12: Impedance Control**

Bit	Control Function	Description	Type	Power Up Condition	0	1
7	Q1_Zout1	Q1 Zout	RW	10	00 = Reserved 01 = 85Ω 10 = 100Ω 11 = Reserved	
6	Q1_Zout0	Q1 Zout	RW			
5	Reserved		RW			
4	Reserved		RW			
3	Q0_Zout1	Q0 Zout	RW			
2	Q0_Zout0	Q0 Zout	RW			
1	Reserved		RW			
0	Reserved		RW			

### Byte 13: Impedance Control

Bit	Control Function	Description	Type	Power Up Condition	0	1
7	Reserved		RW	10	00 = Reserved 01 = 85Ω 10 = 100Ω 11 = Reserved	
6	Reserved		RW			
5	Q3_Zout1	Q3 Zout	RW			
4	Q3_Zout0	Q3 Zout	RW			
3	Reserved		RW			
2	Reserved		RW			
1	Q2_Zout1	Q2 Zout	RW			
0	Q2_Zout0	Q2 Zout	RW			

### Byte 14: OE Termination Control

Bit	Control Function	Description	Type	Power Up Condition	0	1
7	OE1_term1	OE1 Pull up or down	RW	0	00=None	10= Pullup
6	OE1_term0	OE1 Pull up or down	RW	1	01= Pulldown	11=Pullup and Down
5	Reserved		RW	0		
4	Reserved		RW	1		
3	OE0_term1	OE0 Pull up or down	RW	0	00=None	10= Pullup
2	OE0_term0	OE0 Pull up or down	RW	1	01= Pulldown	11=Pullup and Down
1	Reserved			0		
0	Reserved			1		

### Byte 15: OE Termination Control

Bit	Control Function	Description	Type	Power Up Condition	0	1
7	Reserved		RW	0		
6	Reserved		RW	1		
5	OE3_term1	OE3 Pull up or down	RW	0	00=None	10= Pullup
4	OE3_term0	OE3 Pull up or down	RW	1	01= Pulldown	11=Pullup and Down
3	Reserved			0		
2	Reserved			1		
1	OE2_term1	OE2 Pull up or down	RW	0	00=None	10= Pullup
0	OE2_term0	OE2 Pull up or down	RW	1	01= Pulldown	11=Pullup and Down

**PI6CB33401**

**Byte 16: Power Good Termination Control**

Bit	Control Function	Description	Type	Power Up Condition	0	1
7:2	Reserved			0x09		
1	PWRGD_PD1	Clock Power Good and Power Down Pull up or Pull down	RW	1	00=None	10= Pullup
0	PWRGD_PD0		RW	0	01= Pulldown	11=Pullup and Down

**Byte 17: Reserved**

Bit	Control Function	Description	Type	Power Up Condition	0	1
7:0	Reserved			0		

**Byte 18: Enable Pin Control**

Bit	Control Function	Description	Type	Power Up Condition	0	1
7	Reserved		RW	0		
6	OE3_Enable	Sets Enable High or Low	RW	0	Enable = Low	Enable = High
5	Reserved			0		
4	OE2_Enable	Sets Enable High or Low	RW	0	Enable = Low	Enable = High
3	OE1_Enable	Sets Enable High or Low	RW	0	Enable = Low	Enable = High
2	Reserved		RW	0		
1	OE0_Enable	Sets Enable High or Low	RW	0	Enable = Low	Enable = High
0	Reserved		RW	0		

**Byte 19: Power Down Pin Control**

Bit	Control Function	Description	Type	Power Up Condition	0	1
7:1	Reserved			0		
0	PWRGD_PD	PWRGD_PD Active via Pull up or Pull down	RW	0	Power Down = Low	Power Down = High



**PI6CB33401**

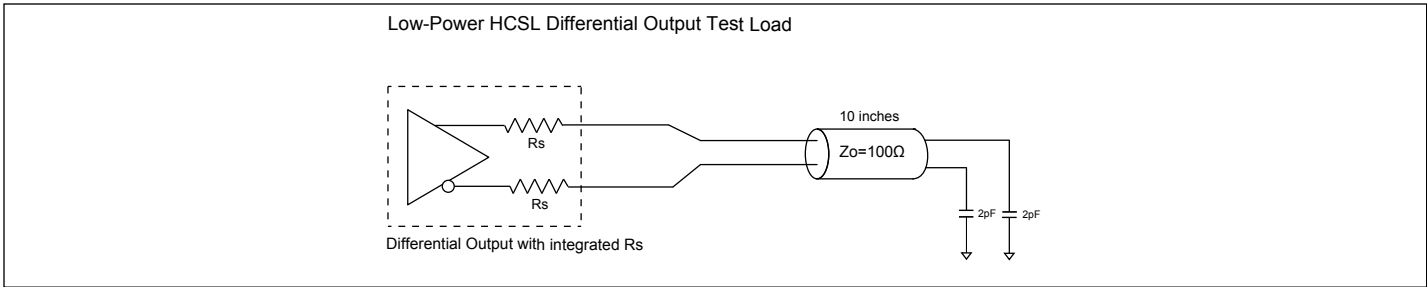

**Figure 1. Low Power HCSL Test Circuit**

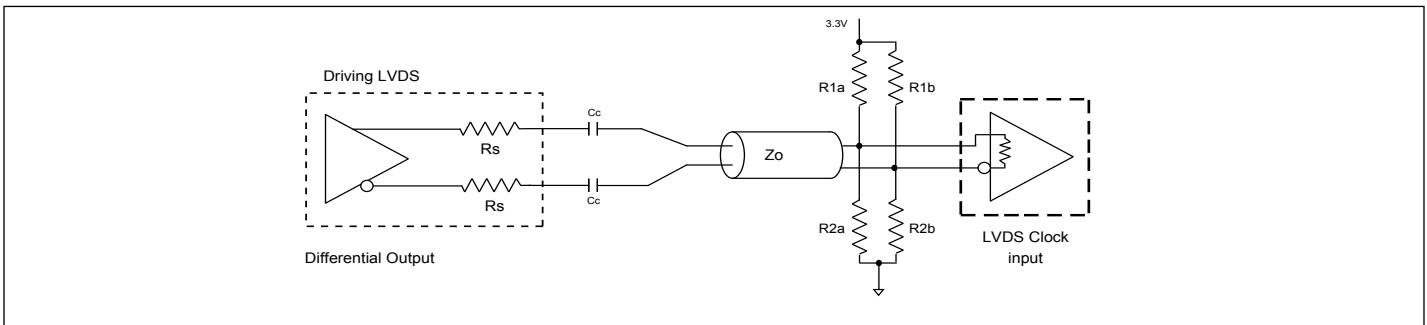

**Figure 2. Differential Output Driving LVDS**

**Alternate Differential Output Terminations**

Component	Receiver with termination	Receiver without termination	Unit
$R_{1a}, R_{1b}$	10,000	140	$\Omega$
$R_{2a}, R_{2b}$	5,600	75	$\Omega$
$C_c$	0.1	0.1	$\mu F$
$V_{CM}$	1.2	1.2	V

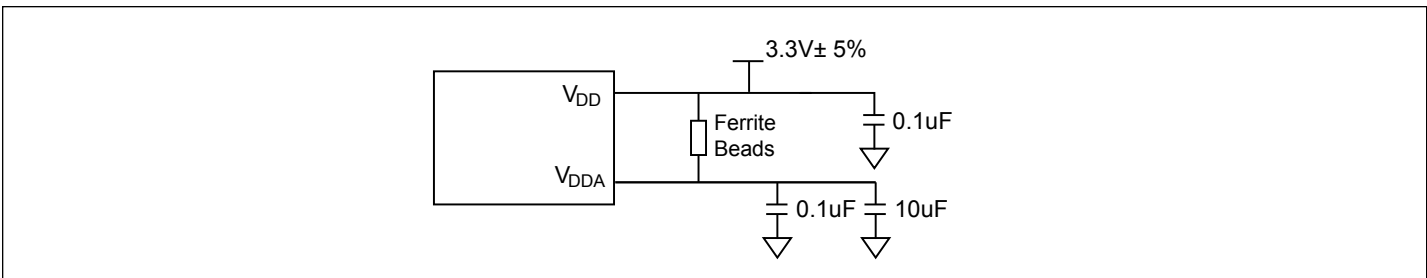

**Figure 3. Power Supply Filter**

**Thermal Characteristics**

Symbol	Parameter	Conditions	Min.	Typ.	Max.	Unit
$\theta_{JA}$	Thermal Resistance Junction to Ambient	Still air			44.7	$^{\circ}C/W$
$\theta_{JC}$	Thermal Resistance Junction to Case				21.7	$^{\circ}C/W$

**PI6CB33401**

**Part Marking**

PI6CB33  
401ZHIE  
YYWWXX

○

YY: Year  
WW: Workweek  
1st X: Assembly Code  
2nd X: Fab Code

**Package Information**

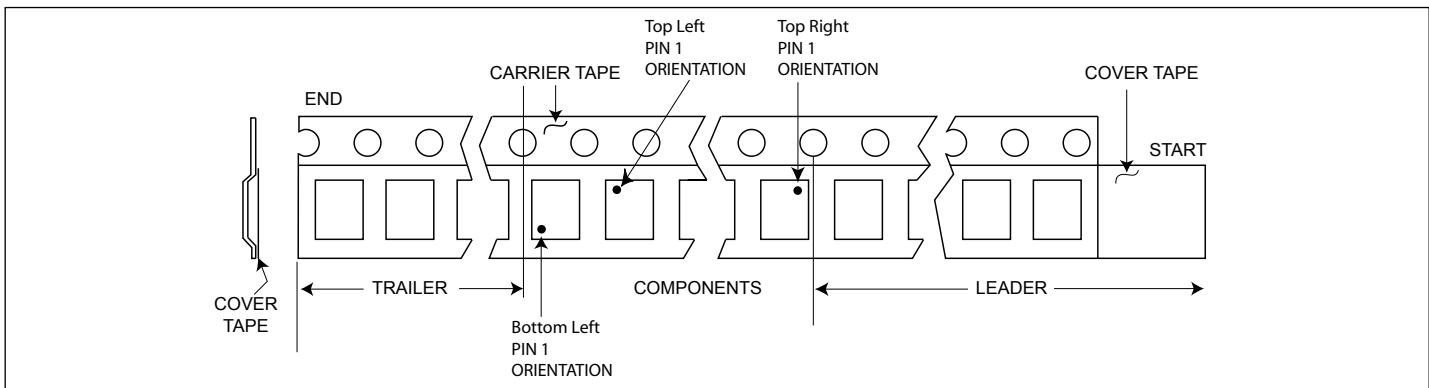

Suffix	Tape Orientation
-13R	
-13RA	

**Packaging Mechanical**

**32-TQFN (ZH)**

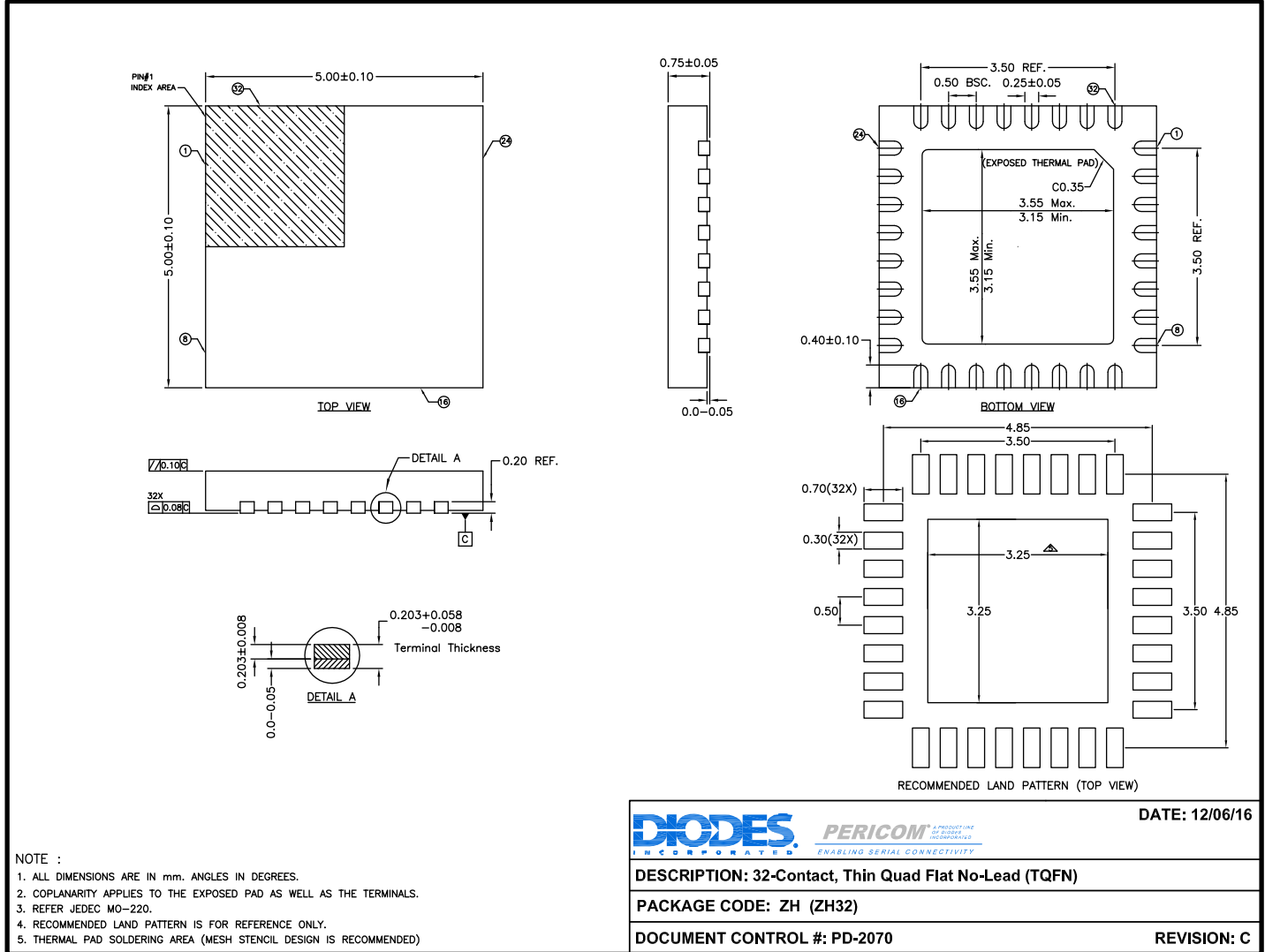

NOTE :

1. ALL DIMENSIONS ARE IN mm. ANGLES IN DEGREES.
2. COPLANARITY APPLIES TO THE EXPOSED PAD AS WELL AS THE TERMINALS.
3. REFER JEDEC MO-220.
4. RECOMMENDED LAND PATTERN IS FOR REFERENCE ONLY.
5. THERMAL PAD SOLDERING AREA (MESH STENCIL DESIGN IS RECOMMENDED)

17-0570

For latest package info.

please check: <http://www.diodes.com/design/support/packaging/pericom-packaging/packaging-mechanicals-and-thermal-characteristics/>

**Ordering Information**

Ordering Code	Package Code	Package Description	Pin 1 Location
PI6CB33401ZHIEX	ZH	32-Contact, Thin Quad Flat No-Lead (TQFN)	Top Right Corner
PI6CB33401ZHIEX-13R	ZH	32-Contact, Thin Quad Flat No-Lead (TQFN)	Top Left Corner

**Notes:**

1. No purposely added lead. Fully EU Directive 2002/95/EC (RoHS), 2011/65/EU (RoHS 2) & 2015/863/EU (RoHS 3) compliant.
2. See <https://www.diodes.com/quality/lead-free/> for more information about Diodes Incorporated's definitions of Halogen- and Antimony-free, "Green" and Lead-free.
3. Halogen- and Antimony-free "Green" products are defined as those which contain <900ppm bromine, <900ppm chlorine (<1500ppm total Br + Cl) and <1000ppm antimony compounds.
4. E = Pb-free and Green
5. X suffix = Tape/Reel
6. For packaging details, go to our website at: <https://www.diodes.com/assets/MediaList-Attachments/Diodes-Package-Information.pdf>

**IMPORTANT NOTICE**

1. DIODES INCORPORATED AND ITS SUBSIDIARIES (“DIODES”) MAKE NO WARRANTY OF ANY KIND, EXPRESS OR IMPLIED, WITH REGARDS TO ANY INFORMATION CONTAINED IN THIS DOCUMENT, INCLUDING, BUT NOT LIMITED TO, THE IMPLIED WARRANTIES OF MERCHANTABILITY, FITNESS FOR A PARTICULAR PURPOSE OR NON-INFRINGEMENT OF THIRD PARTY INTELLECTUAL PROPERTY RIGHTS (AND THEIR EQUIVALENTS UNDER THE LAWS OF ANY JURISDICTION).

2. The Information contained herein is for informational purpose only and is provided only to illustrate the operation of Diodes products described herein and application examples. Diodes does not assume any liability arising out of the application or use of this document or any product described herein. This document is intended for skilled and technically trained engineering customers and users who design with Diodes products. Diodes products may be used to facilitate safety-related applications; however, in all instances customers and users are responsible for (a) selecting the appropriate Diodes products for their applications, (b) evaluating the suitability of the Diodes products for their intended applications, (c) ensuring their applications, which incorporate Diodes products, comply the applicable legal and regulatory requirements as well as safety and functional-safety related standards, and (d) ensuring they design with appropriate safeguards (including testing, validation, quality control techniques, redundancy, malfunction prevention, and appropriate treatment for aging degradation) to minimize the risks associated with their applications.

3. Diodes assumes no liability for any application-related information, support, assistance or feedback that may be provided by Diodes from time to time. Any customer or user of this document or products described herein will assume all risks and liabilities associated with such use, and will hold Diodes and all companies whose products are represented herein or on Diodes’ websites, harmless against all damages and liabilities.

4. Products described herein may be covered by one or more United States, international or foreign patents and pending patent applications. Product names and markings noted herein may also be covered by one or more United States, international or foreign trademarks and trademark applications. Diodes does not convey any license under any of its intellectual property rights or the rights of any third parties (including third parties whose products and services may be described in this document or on Diodes’ website) under this document.

5. Diodes products are provided subject to Diodes’ Standard Terms and Conditions of Sale (<https://www.diodes.com/about/company/terms-and-conditions/terms-and-conditions-of-sales/>) or other applicable terms. This document does not alter or expand the applicable warranties provided by Diodes. Diodes does not warrant or accept any liability whatsoever in respect of any products purchased through unauthorized sales channel.

6. Diodes products and technology may not be used for or incorporated into any products or systems whose manufacture, use or sale is prohibited under any applicable laws and regulations. Should customers or users use Diodes products in contravention of any applicable laws or regulations, or for any unintended or unauthorized application, customers and users will (a) be solely responsible for any damages, losses or penalties arising in connection therewith or as a result thereof, and (b) indemnify and hold Diodes and its representatives and agents harmless against any and all claims, damages, expenses, and attorney fees arising out of, directly or indirectly, any claim relating to any noncompliance with the applicable laws and regulations, as well as any unintended or unauthorized application.

7. While efforts have been made to ensure the information contained in this document is accurate, complete and current, it may contain technical inaccuracies, omissions and typographical errors. Diodes does not warrant that information contained in this document is error-free and Diodes is under no obligation to update or otherwise correct this information. Notwithstanding the foregoing, Diodes reserves the right to make modifications, enhancements, improvements, corrections or other changes without further notice to this document and any product described herein. This document is written in English but may be translated into multiple languages for reference. Only the English version of this document is the final and determinative format released by Diodes.

8. Any unauthorized copying, modification, distribution, transmission, display or other use of this document (or any portion hereof) is prohibited. Diodes assumes no responsibility for any losses incurred by the customers or users or any third parties arising from any such unauthorized use.

Copyright © 2022 Diodes Incorporated

[www.diodes.com](http://www.diodes.com)