

THIS DRAWING IS UNPUBLISHED.

RELEASED FOR PUBLICATION

REVISIONS

© COPYRIGHT - TE Connectivity Ltd.

ALL RIGHTS RESERVED.

P	LTR	DESCRIPTION	DATE	DWN	APVD
	F4	REV PER ECR 09-022345	12OCT09	JR	TM
	F5	REVISED PER ECO-17-008114	28MAY2018	RS	DR
	G	REVISED PER ECO-19-002444	18FEB2019	RS	DR

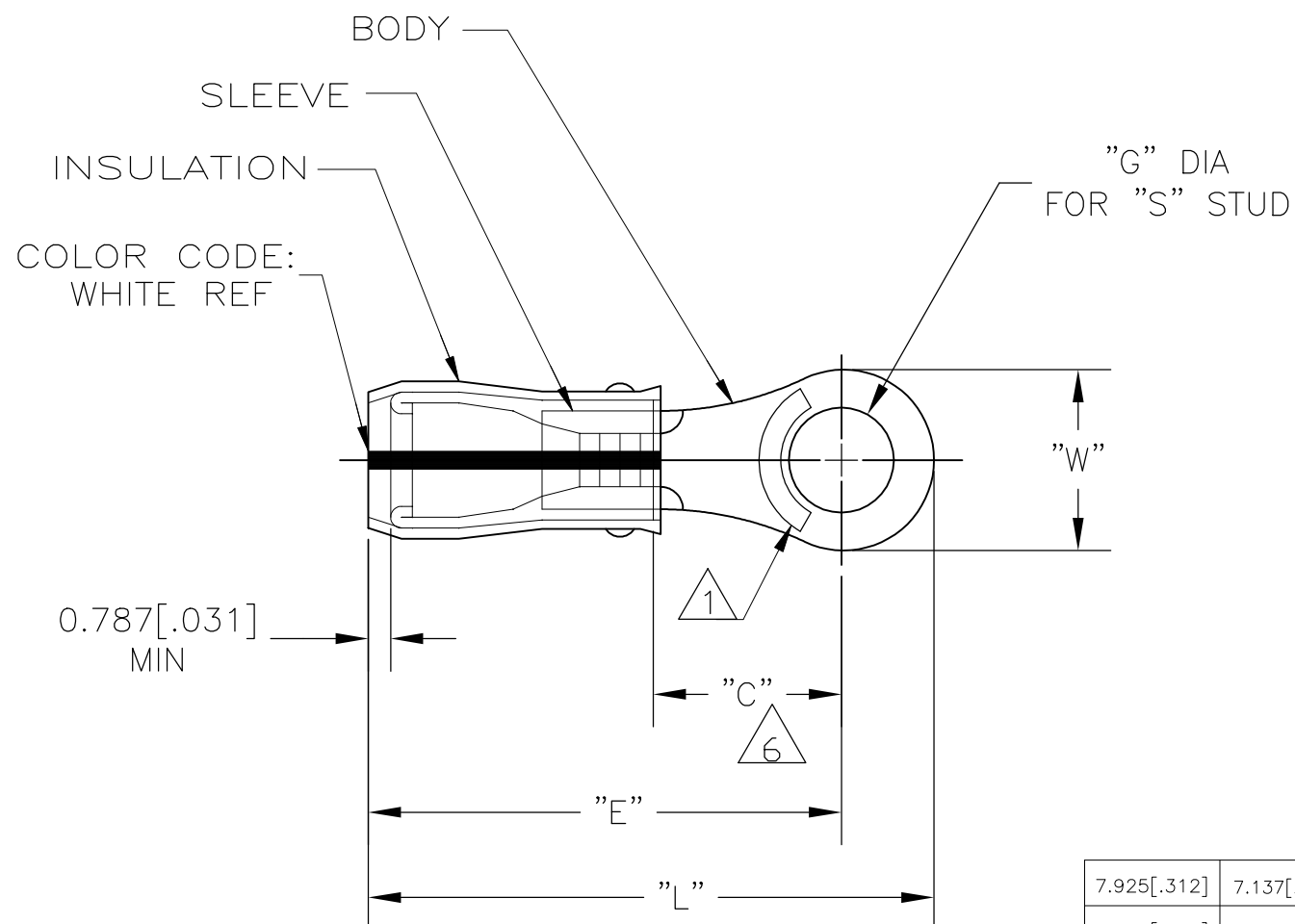

- 1 STAMP AMP 24-20* APPROX AS SHOWN
- 2 WIRE INSULATION DIA: 1.016-2.540[.040-.100]
- 3 BODY MATERIAL THK: 0.584±0.051[.023±.002]
- 4 BODY & SLEEVE: TIN-LEAD (93-7) PLATE PER ASTM B545, (3% MIN LEAD CONTENT)
- 5 BODY & SLEEVE- CU PER ASTM B152 INSULATION - PVF2, COLOR - NATURAL
- 6 APPLIES FROM EDGE OF METAL WIRE BARREL TO CENTER OF STUD HOLE.
- 7 OBSOLETE - NO REPLACEMENT

7.925[.312]	7.137[.281] MIN	16.815[.662] MAX	5.004±0.076[.197±.003]	#10	20.980[.826] MAX	2500	TAPE & REEL	53809-8	7
7.925[.312]	7.137[.281] MIN	16.815[.662] MAX	4.343±0.076[.171±.003]	#8	20.980[.826] MAX	2500	TAPE & REEL	53809-7	7
7.925[.312]	7.137[.281] MIN	16.815[.662] MAX	5.004±0.076[.197±.003]	#10	20.980[.826] MAX	1000	LOOSE PIECE	53809-6	7
7.925[.312]	7.137[.281] MIN	16.815[.662] MAX	4.343±0.076[.171±.003]	#8	20.980[.826] MAX	1000	LOOSE PIECE	53809-5	7
7.137[.281]	6.350[.250] MIN	16.027[.631] MAX	3.683±0.076[.145±.003]	#6	19.787[.779] MAX	2500	TAPE & REEL	53809-4	7
7.137[.281]	6.350[.250] MIN	16.027[.631] MAX	3.023±0.076[.119±.003]	#4	19.787[.779] MAX	2500	TAPE & REEL	53809-3	7
7.137[.281]	6.350[.250] MIN	16.027[.631] MAX	3.683±0.076[.145±.003]	M3.5[#6]	19.787[.779] MAX	1000	LOOSE PIECE	53809-2	7
7.137[.281]	6.350[.250] MIN	16.027[.631] MAX	3.023±0.076[.119±.003]	#4	19.787[.779] MAX	1000	LOOSE PIECE	53809-1	7
"W"	"C"	"E"	"G" DIA	"S"	"L"	QTY	PACKAGE TYPE	PART NO	

CUSTOMER SERVICE SYSTEMS

MAX RECOMMENDED OPERATING TEMPERATURE: 150°C[302°F] MAX

VOLTAGE RATING: -

CIRCULAR MIL AREA: 0.16-0.65mm² [320-1,290] STRANDED

THIS DRAWING IS A CONTROLLED DOCUMENT FOR AMP INCORPORATED. IT IS SUBJECT TO CHANGE AND THE CONTROLLING ENGINEERING ORGANIZATION SHOULD BE CONTACTED FOR THE LATEST REVISION.

THIS DRAWING IS A CONTROLLED DOCUMENT.

DIMENSIONS: mm [INCHES]

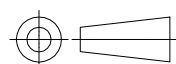

MATERIAL

TOLERANCES UNLESS OTHERWISE SPECIFIED:

- 0 PLC ± -
- 1 PLC ± -
- 2 PLC ± -
- 3 PLC ± 0.127[.005]
- 4 PLC ± -
- ANGLES ± -
- FINISH



DWN JR RUTH 28JUL05

CHK T MICHIELUTTI 28JUL05

APVD T MICHIELUTTI 28JUL05

PRODUCT SPEC

APPLICATION SPEC

WEIGHT -

CUSTOMER DRAWING



NAME: TERMINAL, RING TONGUE, PVF2, PIDG WIRE SIZE: 24-20 AWG

SIZE: A3 CAGE CODE: 00779 DRAWING NO: C-53809 RESTRICTED TO: -

SCALE: 4:1 SHEET: 1 OF 1 REV: G