

## Precision 1.25V & 2.50V Low Voltage FGA™ References

The ISL60002 FGA™ voltage references are very high precision analog voltage references fabricated in Intersil's proprietary Floating Gate Analog technology and feature low (2.7V to 5.5V) supply voltage operation at ultra-low 400nA operating current.

Additional features include guaranteed absolute initial accuracy as low as  $\pm 1.0\text{mV}$ , 20ppm/°C temperature coefficient and long-term stability of 10ppm/ $\sqrt{1,000\text{Hrs}}$ . The initial accuracy and thermal stability performance of the ISL60002 family plus the low supply voltage and 400nA power consumption eliminates the need to compromise thermal stability for reduced power consumption making it an ideal companion to high resolution, low power data conversion systems.

### Ordering Information

PART NUMBER	TEMP. RANGE (°C)	PACKAGE	GRADE	V <sub>OUT</sub> OPTION
ISL60002BIH312	-40 to 85	3 Ld SOT23	$\pm 1.0\text{mV}$ , 20ppm/°C	1.25V
ISL60002BIH325	-40 to 85	3 Ld SOT23	$\pm 1.0\text{mV}$ , 20ppm/°C	2.5V
ISL60002BIB812	-40 to 85	8 Ld SOIC	$\pm 1.0\text{mV}$ , 20ppm/°C	1.25V
ISL60002BIB825	-40 to 85	8 Ld SOIC	$\pm 1.0\text{mV}$ , 20ppm/°C	2.5V
ISL60002CIH312	-40 to 85	3 Ld SOT23	$\pm 2.5\text{mV}$ , 20ppm/°C	1.25V
ISL60002CIH325	-40 to 85	3 Ld SOT23	$\pm 2.5\text{mV}$ , 20ppm/°C	2.5V
ISL60002DIH312	-40 to 85	3 Ld SOT23	$\pm 5.0\text{mV}$ , 20ppm/°C	1.25V
ISL60002DIH325	-40 to 85	3 Ld SOT23	$\pm 5.0\text{mV}$ , 20ppm/°C	2.5V
ISL60002CIB812	-40 to 85	8 Ld SOIC	$\pm 2.5\text{mV}$ , 20ppm/°C	1.25V
ISL60002CIB825	-40 to 85	8 Ld SOIC	$\pm 2.5\text{mV}$ , 20ppm/°C	2.5V
ISL60002DIB812	-40 to 85	8 Ld SOIC	$\pm 5.0\text{mV}$ , 20ppm/°C	1.25V
ISL60002DIB825	-40 to 85	8 Ld SOIC	$\pm 5.0\text{mV}$ , 20ppm/°C	2.5V

### Features

- Reference Voltage . . . . . 1.25V, & 2.50V
- Absolute Initial Accuracy Options . . . . .  $\pm 1.0\text{mV}$ ,  $\pm 2.5\text{mV}$ , &  $\pm 5.0\text{mV}$
- Supply Voltage Range . . . . . 2.7V to 5.5V
- Ultra-Low Supply Current . . . . . 400nA typ
- Low 20ppm/°C Temperature Coefficient
- 10ppm/ $\sqrt{1,000\text{Hrs}}$ . Long Term Stability
- 7mA Source & Sink Current
- ESD Protection. . . . . 5kV (Human Body Model)
- Standard 8 Ld SOIC & 3 Ld SOT23 packaging
- Temperature Range . . . . . -40°C to +85°C

### Applications

- High Resolution A/Ds & D/As
- Digital Meters
- Bar Code Scanners
- Mobile Communications
- PDA's and Notebooks
- Battery Management Systems
- Medical Systems

### Pinouts

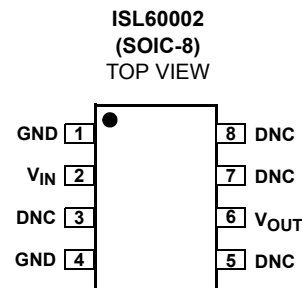
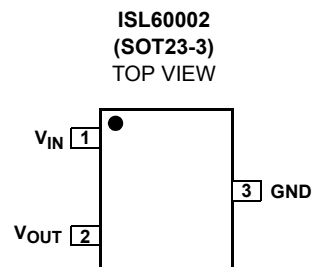

**Typical Application**

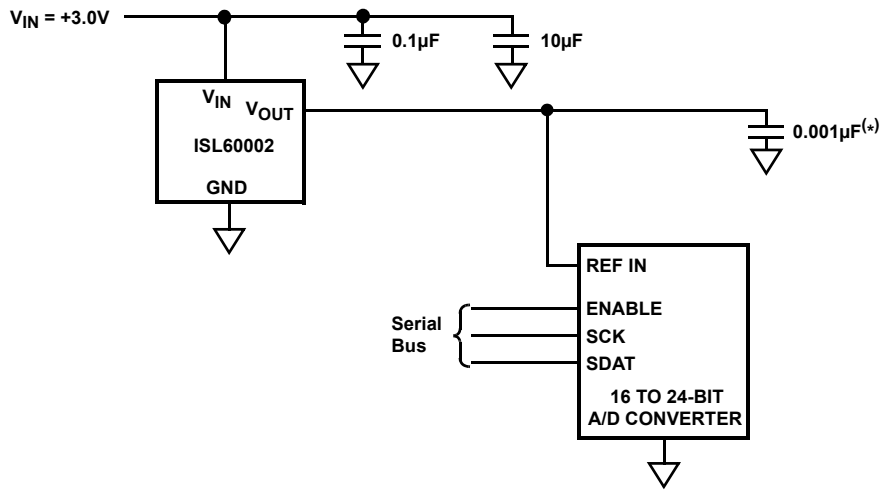

(\*)Also see Figure 3 in Applications Information

**Pin Descriptions**

PIN NAME	DESCRIPTION
GND	Ground Connection
$V_{IN}$	Power Supply Input Connection
$V_{OUT}$	Voltage Reference Output Connection
DNC	Do Not Connect; Internal Connection – Must Be Left Floating

**Absolute Maximum Ratings**

Storage Temperature Range . . . . . -65°C to + 125°C  
 Max Voltage  $V_{IN}$  to Gnd. . . . . -0.5V to +6.5V  
 Max Voltage  $V_{OUT}$  to Gnd (\*) :  
 ISL60002,  $V_{OUT} = 1.25V$ . . . . . -0.5V to +2.25V  
 ISL60002,  $V_{OUT} = 2.50V$ . . . . . -0.5V to +3.50V  
 Voltage on “DNC” pins . . . . No connections permitted to these pins.  
 Lead Temperature, soldering (\*) . . . . . +225°C  
 (\*) note: maximum duration = 10 seconds

**Recommended Operating Conditions**

Temperature Range (Industrial) . . . . . -40°C to 85°C

**ESD Ratings**

Body test . . . . . 5kV

*CAUTION: Absolute Maximum Ratings are limits which may result in impaired reliability and/or permanent damage to the device. These are stress ratings provided for information only and functional operation of the device at these or any other conditions beyond those indicated in the operational sections of this specification are not implied.*

*For guaranteed specifications and test conditions, see Electrical Characteristics.*

*The guaranteed specifications apply only for the test conditions listed. Some performance characteristics may degrade when the device is not operated under the listed test conditions.*

**Electrical Specifications ISL60002,  $V_{OUT} = 1.25V$**  Operating Conditions:  $V_{IN} = 3.0V$ ,  $I_{OUT} = 0mA$ ,  $C_{OUT} = 0.001\mu F$ ,  $T_A = -40$  to +85°C, unless otherwise specified.

SYMBOL	PARAMETER	CONDITIONS	MIN	TYP	MAX	UNITS
$V_{OUT}$	Output Voltage			1.250		V
$V_{OA}$	$V_{OUT}$ Accuracy	$T_A = 25^\circ C$				
		ISL60002B12	-1.0		+1.0	mV
		ISL60002C12	-2.5		+2.5	mV
		ISL60002D12	-5.0		+5.0	mV
$TC V_{OUT}$	Output Voltage Temperature Coefficient (Note 1)				20	ppm/°C
$V_{IN}$	Input Voltage Range		2.7		5.5	V
$I_{IN}$	Supply Current			400	900	nA
$\Delta V_{OUT}/\Delta V_{IN}$	Line Regulation	$+2.7V \leq V_{IN} \leq +5.5V$		100	250	$\mu V/V$
$\Delta V_{OUT}/\Delta I_{OUT}$	Load Regulation	Sourcing: $0mA \leq I_{OUT} \leq 7mA$		25	60	$\mu V/mA$
		Sinking: $-7mA \leq I_{OUT} \leq 0mA$		25	60	$\mu V/mA$
$\Delta V_{OUT}/\Delta t$	Long Term Stability (Note 4)	$T_A = 25^\circ C$		10		$\frac{ppm}{\sqrt{1kHrs}}$
$\Delta V_{OUT}/\Delta T_A$	Thermal Hysteresis (Note 2)	$\Delta T_A = 125^\circ C$		100		ppm
$I_{SC}$	Short Circuit Current (Note 3)	$T_A = 25^\circ C$ , $V_{OUT}$ tied to Gnd		50	80	mA
$V_N$	Output Voltage Noise	$0.1Hz \leq f \leq 10Hz$		30		$\mu V_{p-p}$

NOTES:

- Over the specified temperature range. Temperature coefficient is measured by the box method whereby the change in  $V_{OUT}$  is divided by the temperature range; in this case, -40°C to +85°C = 125°C.
- Thermal Hysteresis is the change in  $V_{OUT}$  measured @  $T_A = 25^\circ C$  after temperature cycling over a specified range,  $\Delta T_A$ .  $V_{OUT}$  is read initially at  $T_A = 25^\circ C$  for the device under test. The device is temperature cycled and a second  $V_{OUT}$  measurement is taken at 25°C. The difference between the initial  $V_{OUT}$  reading and the second  $V_{OUT}$  reading is then expressed in ppm. For  $\Delta T_A = 125^\circ C$ , the device under is cycled from +25°C to +85°C to -40°C to +25°C.
- Guaranteed by device characterization and/or correlation to other device tests.
- FGA™ voltage reference long term drift is a logarithmic characteristic. Changes that occur after the first few hundred hours of operation are significantly smaller with time, asymptotically approaching zero beyond 2000 hours. Because of this decreasing characteristic, long-term drift is specified in  $ppm/\sqrt{1kHr}$ .

## ISL60002

**Electrical Specifications: ISL60002,  $V_{OUT} = 2.50V$**  Operating Conditions:  $V_{IN} = 3.0V$ ,  $I_{OUT} = 0mA$ ,  $C_{OUT} = 0.001\mu F$ ,  $T_A = -40$  to  $+85^\circ C$ , unless otherwise specified.

SYMBOL	PARAMETER	CONDITIONS	MIN	TYP	MAX	UNITS
$V_{OUT}$	Output Voltage			2.500		V
$V_{OA}$	$V_{OUT}$ Accuracy @	$T_A = 25^\circ C$				
		ISL60002B25	-1.0		+1.0	mV
		ISL60002C25	-2.5		+2.5	mV
		ISL60002D25	-5.0		+5.0	mV
TC $V_{OUT}$	Output Voltage Temperature Coefficient (Note 1)				20	ppm/ $^\circ C$
$V_{IN}$	Input Voltage Range		2.7		5.5	V
$I_{IN}$	Supply Current			400	900	nA
$\Delta V_{OUT}/\Delta V_{IN}$	Line Regulation	$+2.7V \leq V_{IN} \leq +5.5V$		100	250	$\mu V/V$
$\Delta V_{OUT}/\Delta I_{OUT}$	Load Regulation	Sourcing: $0mA \leq I_{OUT} \leq 7mA$		25	60	$\mu V/mA$
		Sinking: $-7mA \leq I_{OUT} \leq 0mA$		25	60	$\mu V/mA$
$\Delta V_{OUT}/\Delta t$	Long Term Stability (Note 4)	$T_A = 25^\circ C$		10		$\frac{ppm}{\sqrt{1kHrs}}$
$\Delta V_{OUT}/\Delta T_A$	Thermal Hysteresis (Note 2)	$\Delta T_A = 125^\circ C$		100		ppm
$I_{SC}$	Short Circuit Current (Note 3)	$T_A = 25^\circ C$ , $V_{OUT}$ tied to Gnd		50	80	mA
$V_N$	Output Voltage Noise	$0.1Hz \leq f \leq 10Hz$		30		$\mu V_{p-p}$

**NOTES:**

- Over the specified temperature range. Temperature coefficient is measured by the box method whereby the change in  $V_{OUT}$  is divided by the temperature range; in this case,  $-40^\circ C$  to  $+85^\circ C = 125^\circ C$ .
- Thermal Hysteresis is the change in  $V_{OUT}$  measured @  $T_A = 25^\circ C$  after temperature cycling over a specified range,  $\Delta T_A$ .  $V_{OUT}$  is read initially at  $T_A = 25^\circ C$  for the device under test. The device is temperature cycled and a second  $V_{OUT}$  measurement is taken at  $25^\circ C$ . The difference between the initial  $V_{OUT}$  reading and the second  $V_{OUT}$  reading is then expressed in ppm. For  $\Delta T_A = 125^\circ C$ , the device under is cycled from  $+25^\circ C$  to  $+85^\circ C$  to  $-40^\circ C$  to  $+25^\circ C$ .
- Guaranteed by device characterization and/or correlation to other device tests.
- FGA™ voltage reference long term drift is a logarithmic characteristic. Changes that occur after the first few hundred hours of operation are significantly smaller with time, asymptotically approaching zero beyond 2000 hours. Because of this decreasing characteristic, long-term drift is specified in  $ppm/\sqrt{1kHr}$ .

**Typical Performance Characteristic Curves: ISL60002,  $V_{OUT} = 1.25V$**

( $V_{IN} = 3.0V$ ,  $I_{OUT} = 0mA$ ,  $T_A = 25^\circ C$  unless otherwise specified)

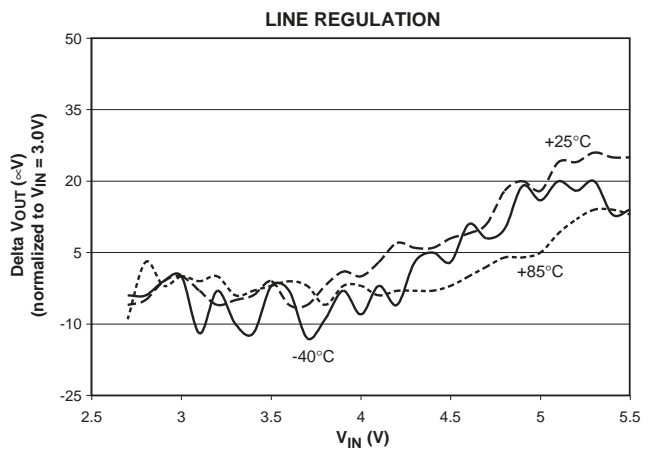
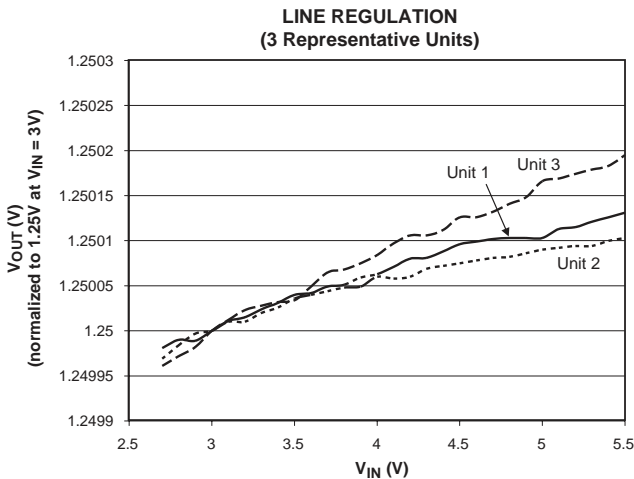
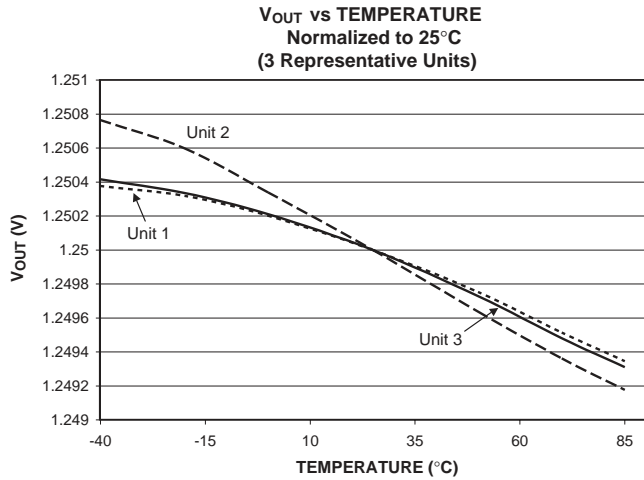
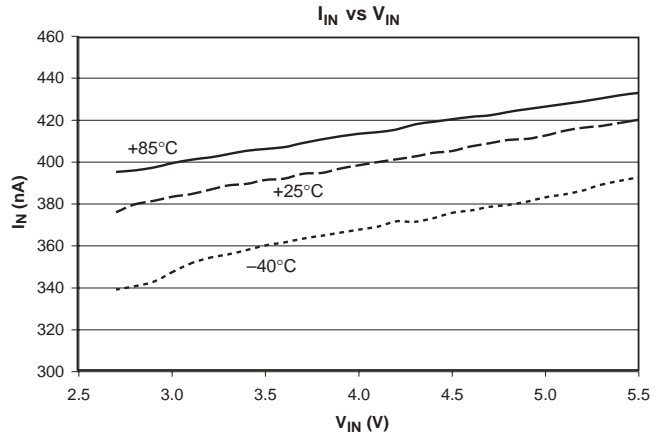
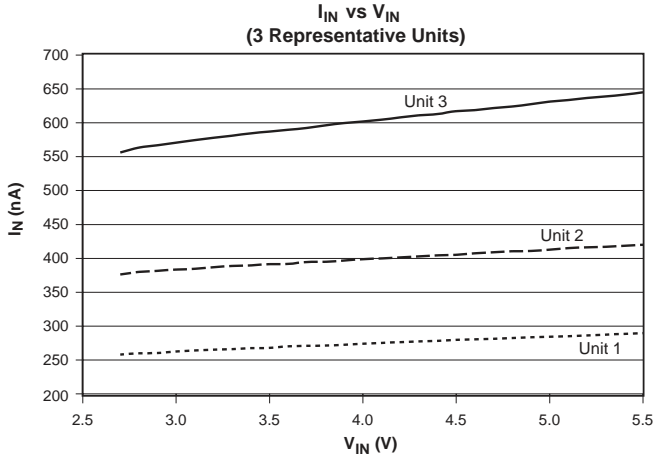

**Typical Performance Characteristic Curves: ISL60002,  $V_{OUT} = 1.25V$**

( $V_{IN} = 3.0V$ ,  $I_{OUT} = 0mA$ ,  $T_A = 25^\circ C$  unless otherwise specified)

**LINE TRANSIENT RESPONSE**

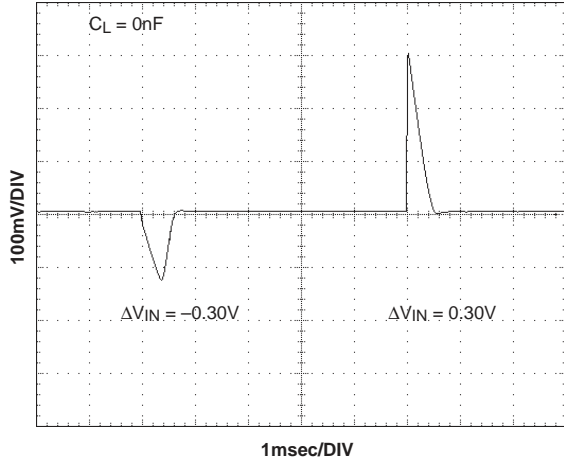

**LINE TRANSIENT RESPONSE**

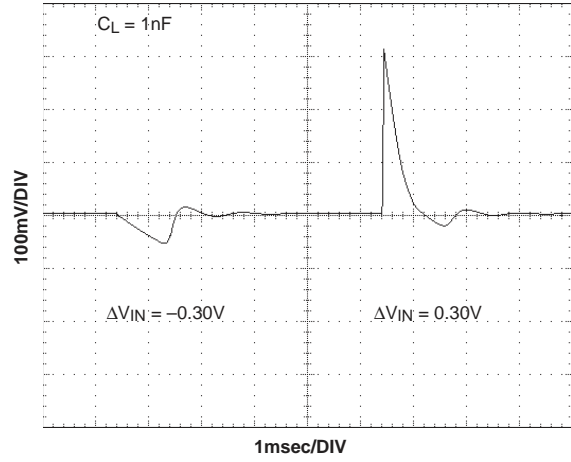

**PSRR vs CAP LOAD**

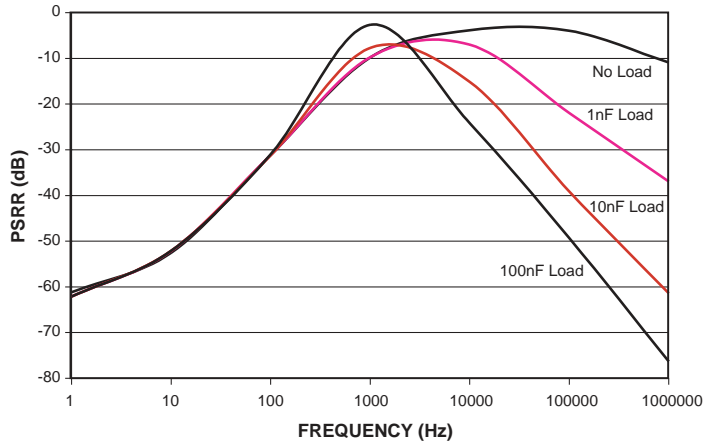

**LOAD REGULATION**

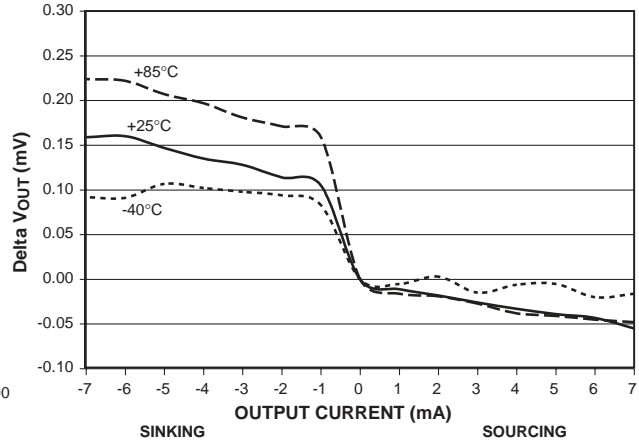

**LOAD TRANSIENT RESPONSE**

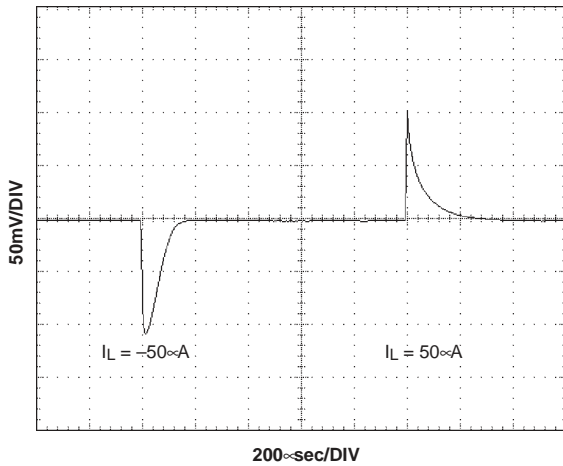

**LOAD TRANSIENT RESPONSE**

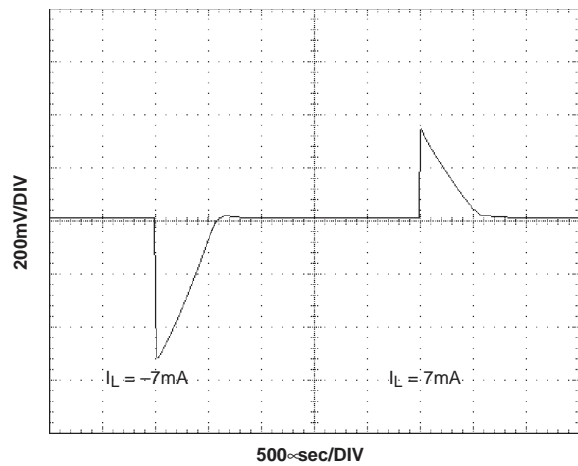

**Typical Performance Characteristic Curves: ISL60002,  $V_{OUT} = 1.25V$**

( $V_{IN} = 3.0V$ ,  $I_{OUT} = 0mA$ ,  $T_A = 25^\circ C$  unless otherwise specified)

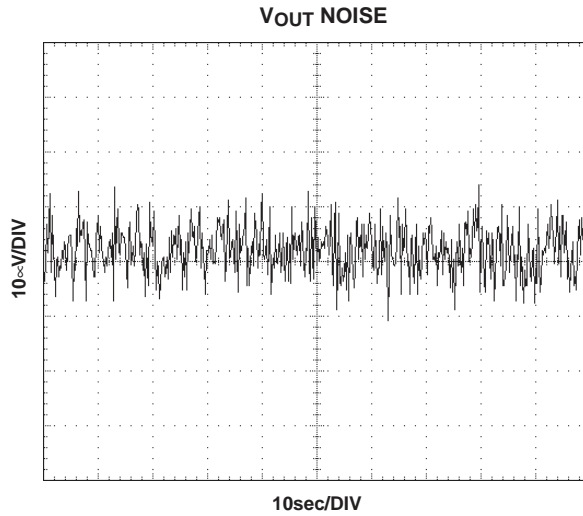
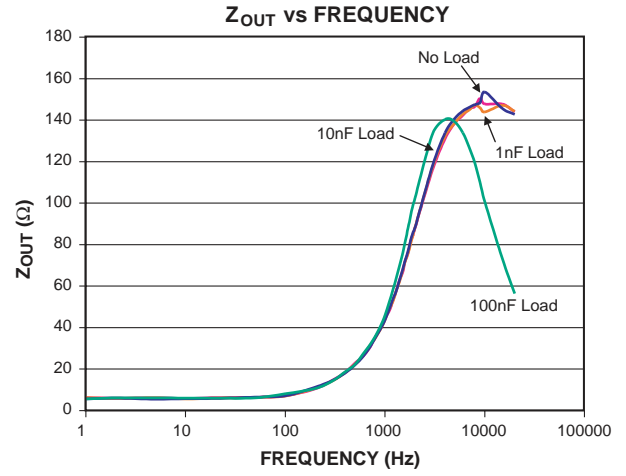
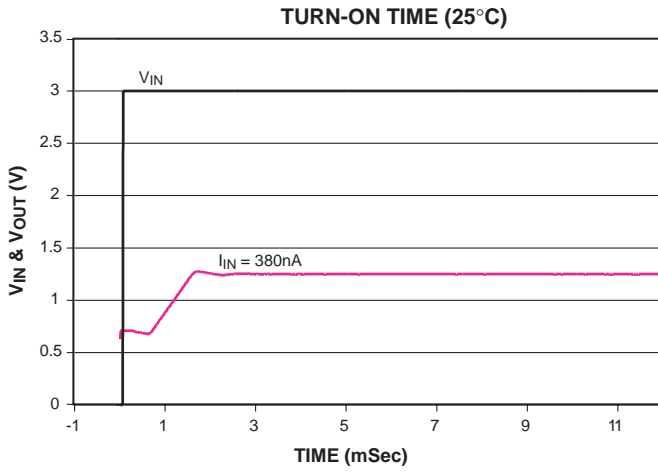

**Typical Performance Characteristic Curves: ISL60002,  $V_{OUT} = 2.50V$**

( $V_{IN} = 3.0V$ ,  $I_{OUT} = 0mA$ ,  $T_A = 25^\circ C$  unless otherwise specified)

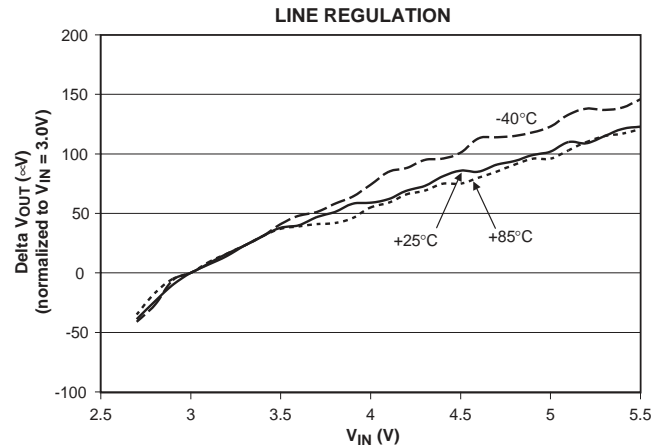
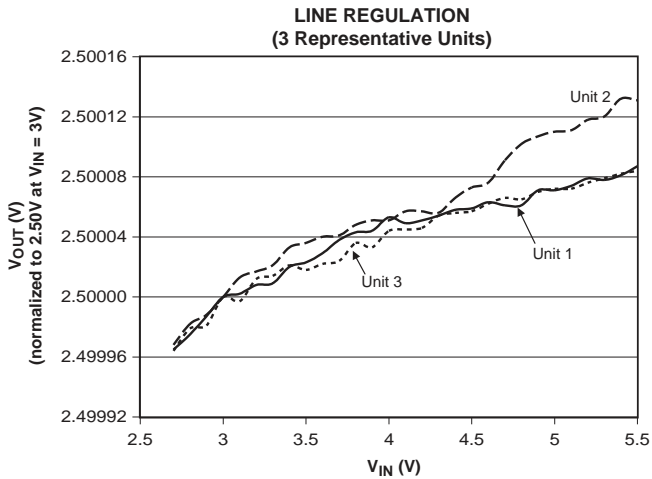
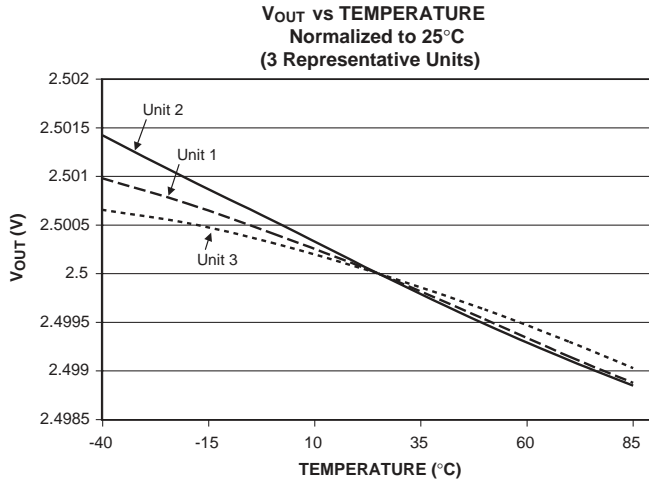
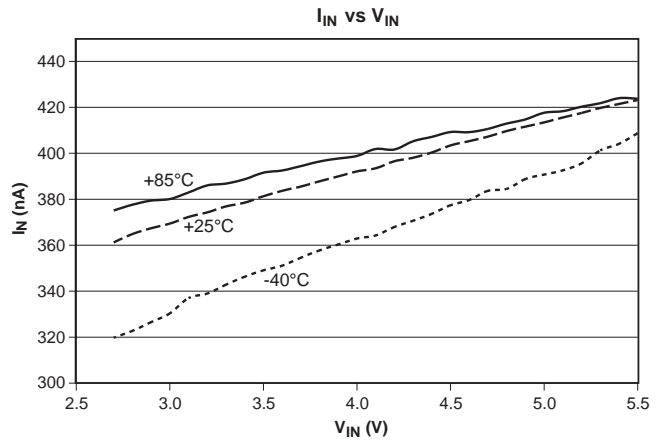
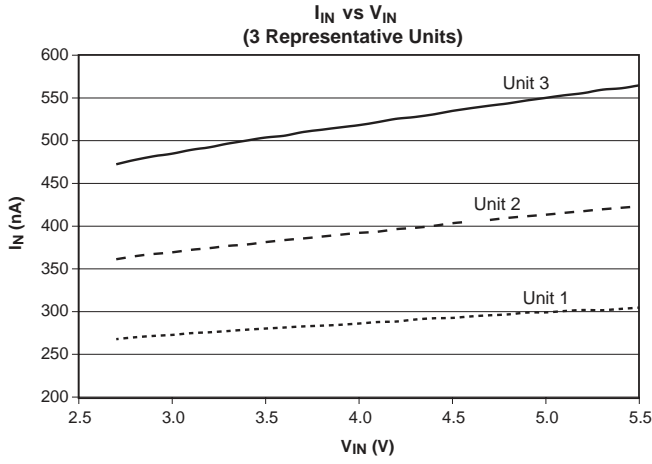



**Typical Performance Characteristic Curves: ISL60002,  $V_{OUT} = 2.50V$**

( $V_{IN} = 3.0V$ ,  $I_{OUT} = 0mA$ ,  $T_A = 25^\circ C$  unless otherwise specified)

**LINE TRANSIENT RESPONSE**

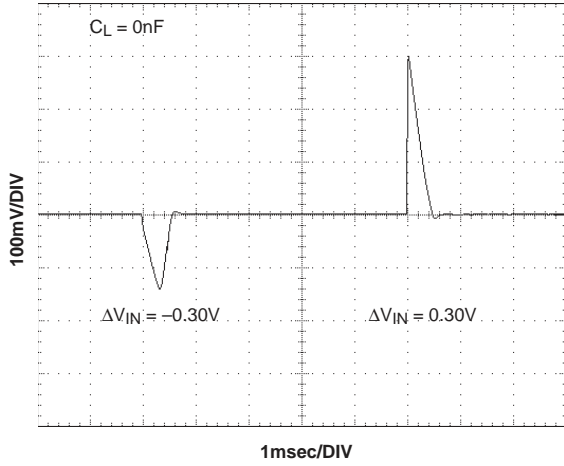

**LINE TRANSIENT RESPONSE**

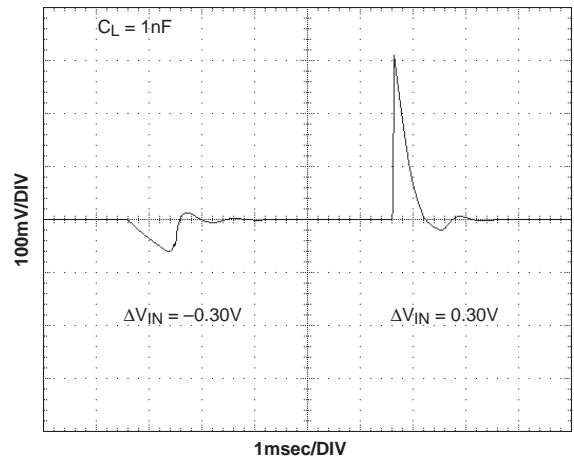

**PSRR vs CAP LOAD**

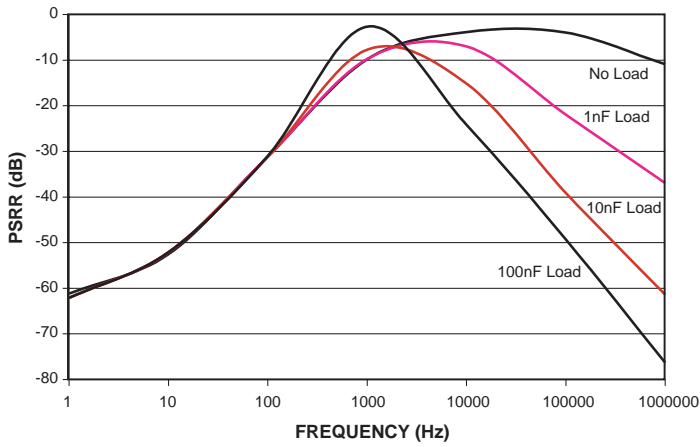

**LOAD REGULATION**

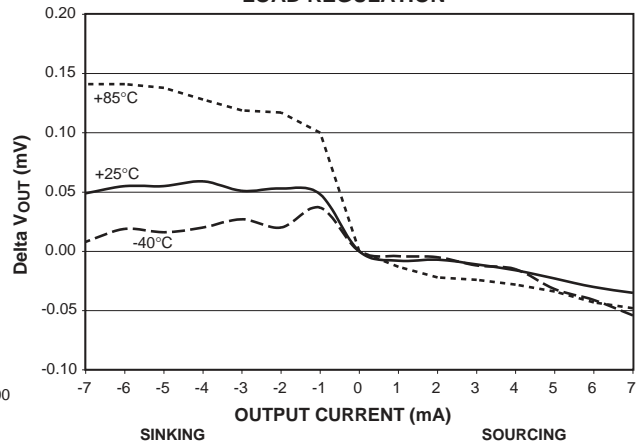

**LOAD TRANSIENT RESPONSE**

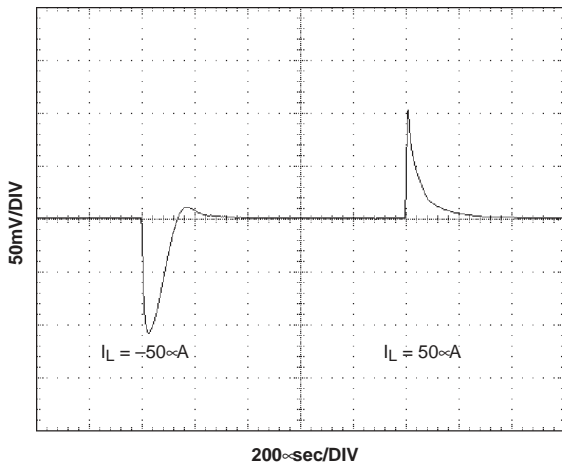

**LOAD TRANSIENT RESPONSE**

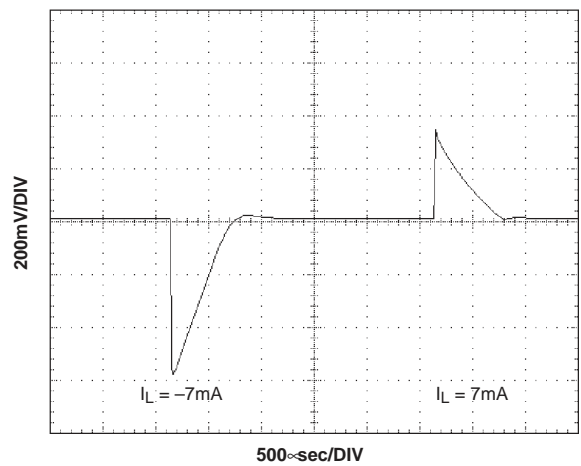

**Typical Performance Characteristic Curves: ISL60002,  $V_{OUT} = 2.50V$**

( $V_{IN} = 3.0V$ ,  $I_{OUT} = 0mA$ ,  $T_A = 25^\circ C$  unless otherwise specified)

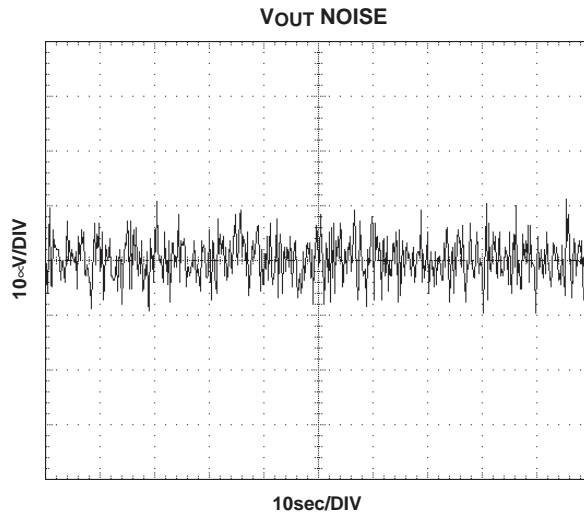
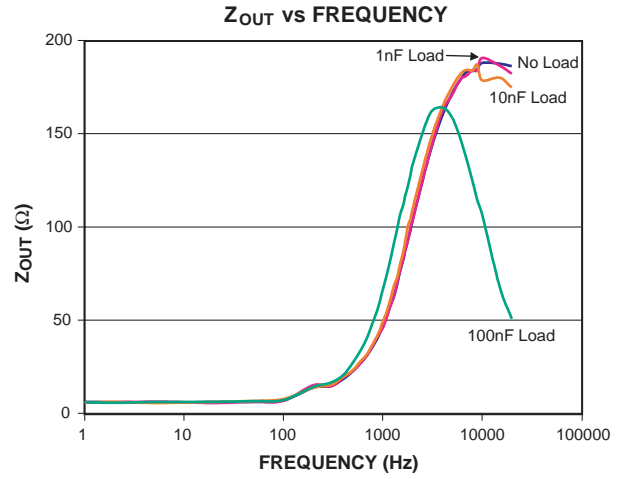
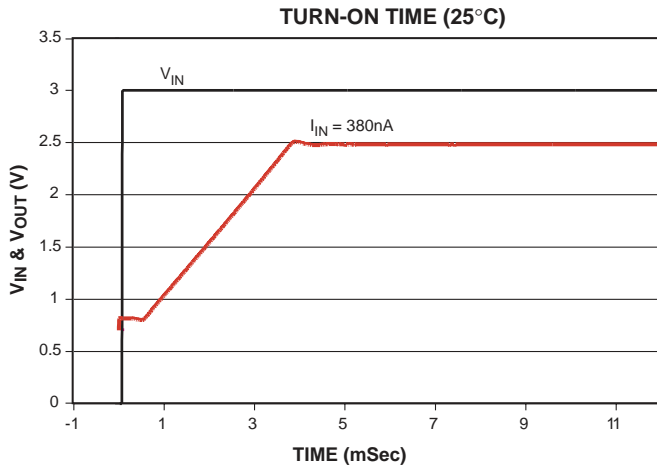

## Applications Information

### FGA Technology

The ISL60002 series of voltage references use the floating gate technology to create references with very low drift and supply current. Essentially the charge stored on a floating gate cell is set precisely in manufacturing. The reference voltage output itself is a buffered version of the floating gate voltage. The resulting reference device has excellent characteristics which are unique in the industry: very low temperature drift, high initial accuracy, and almost zero supply current. Also, the reference voltage itself is not limited by voltage bandgaps or zener settings, so a wide range of reference voltages can be programmed (standard voltage settings are provided, but customer-specific voltages are available).

The process used for these reference devices is a floating gate CMOS process, and the amplifier circuitry uses CMOS transistors for amplifier and output transistor circuitry. While providing excellent accuracy, there are limitations in output noise level and load regulation due to the MOS device characteristics. These limitations are addressed with circuit techniques discussed in other sections.

### Nanopower Operation

Reference devices achieve their highest accuracy when powered up continuously, and after initial stabilization has taken place. This drift can be eliminated by leaving the power on continuously.

The ISL60002 is the first high precision voltage reference with ultra low power consumption that makes it possible to leave power on continuously in battery operated circuits. The ISL60002 consumes extremely low supply current due to the proprietary FGA technology. Supply current at room temperature is typically 400nA which is 1 to 2 orders of magnitude lower than competitive devices. Application circuits using battery power will benefit greatly from having an accurate, stable reference which essentially presents no load to the battery.

In particular, battery powered data converter circuits that would normally require the entire circuit to be disabled when not in use can remain powered up between conversions as shown in Figure 1. Data acquisition circuits providing 12 to 24 bits of accuracy can operate with the reference device continuously biased with no power penalty, providing the highest accuracy and lowest possible long term drift.

Other reference devices consuming higher supply currents will need to be disabled in between conversions to conserve battery capacity. Absolute accuracy will suffer as the device is biased and requires time to settle to its final value, or, may not actually settle to a final value as power on time may be short.

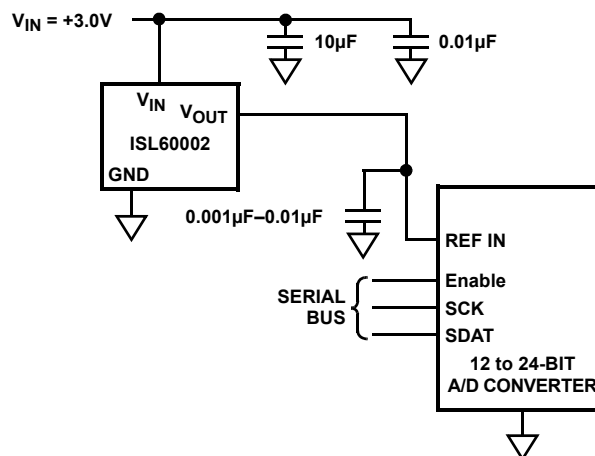

FIGURE 1.

### Board mounting Considerations

For applications requiring the highest accuracy, board mounting location should be reviewed. Placing the device in areas subject to slight twisting can cause degradation of the accuracy of the reference voltage due to die stresses. It is normally best to place the device near the edge of a board, or the shortest side, as the axis of bending is most limited at that location. Obviously mounting the device on flexprint or extremely thin PC material will likewise cause loss of reference accuracy.

### Noise Performance and Reduction:

The output noise voltage in a 0.1Hz to 10Hz bandwidth is typically 30µVp-p. This is shown in the plot in the Typical Performance Curves. The noise measurement is made with a bandpass filter made of a 1 pole high-pass filter with a corner frequency at 0.1Hz and a 2-pole low-pass filter with a corner frequency at 12.6GHz to create a filter with a 9.9Hz bandwidth. Noise in the 10kHz to 1MHz bandwidth is approximately 400µVp-p with no capacitance on the output, as shown in Figure 2. These noise measurements are made with a 2 decade bandpass filter made of a 1 pole high-pass filter with a corner frequency at 1/10 of the center frequency and 1-pole low-pass filter with a corner frequency at 10 times the center frequency. Figure 2 also shows the noise in the 10kHz to 1MHz band can be reduced to about 50µVp-p using a .001µF capacitor on the output. Noise in the 1kHz to 100kHz band can be further reduced using a 0.1µF capacitor on the output, but noise in the 1Hz to 100Hz band increases due to instability of the very low power amplifier with a 0.1µF capacitance load. For load capacitances above 0.001µF the noise reduction network shown in fig. 3 is recommended. This network reduces noise significantly over the full bandwidth. As shown in figure 2, noise is reduced to less than 40µVp-p from 1Hz to 1MHz using this network with a 0.01µF capacitor and a 2kΩ resistor in series with a 10µF capacitor.

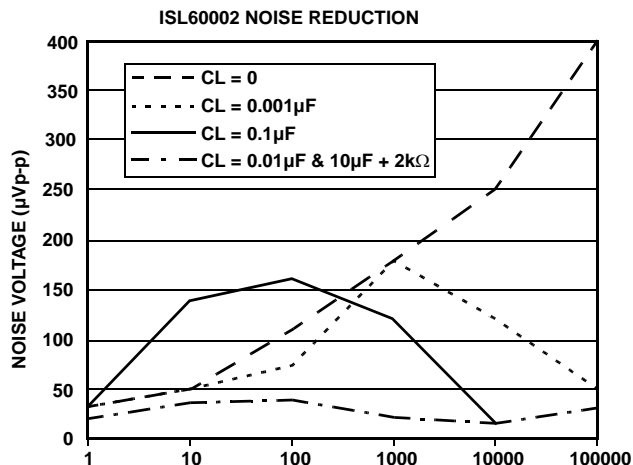

FIGURE 2.

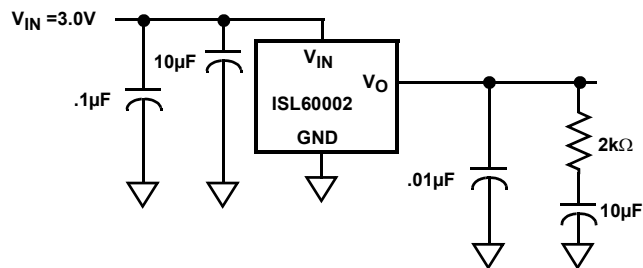

FIGURE 3.

**Turn-On Time**

The ISL60002 devices have ultra-low supply current and thus the time to bias up internal circuitry to final values will be longer than with higher power references. Normal turn-on time is typically 7ms. This is shown in Figure 4. Since devices can vary in supply current down to 300nA, turn-on time can last up to about 12ms. Care should be taken in system design to include this delay before measurements or conversions are started.

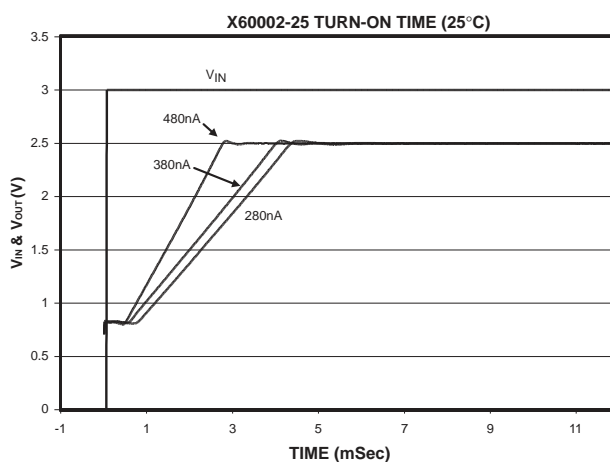
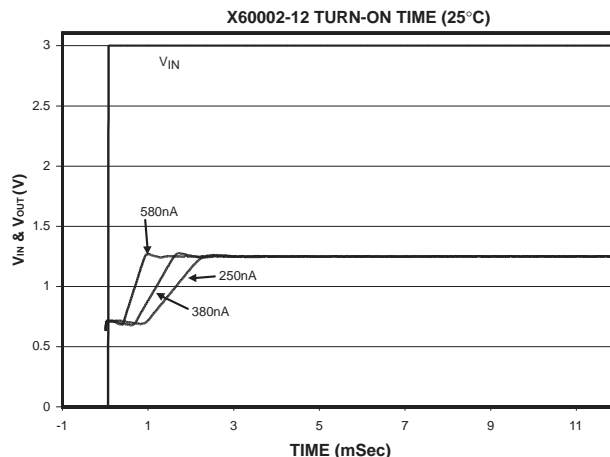

FIGURE 4.

**Temperature Coefficient**

The limits stated for temperature coefficient (tempco) are governed by the method of measurement. The overwhelming standard for specifying the temperature drift of a reference is to measure the reference voltage at two temperatures, take the total variation, ( $V_{HIGH} - V_{LOW}$ ), and divide by the temperature extremes of measurement ( $T_{HIGH} - T_{LOW}$ ). The result is divided by the nominal reference voltage (at  $T = 25^\circ\text{C}$ ) and multiplied by  $10^6$  to yield ppm/ $^\circ\text{C}$ . This is the "Box" method for specifying temperature coefficient.

Typical Application Circuits

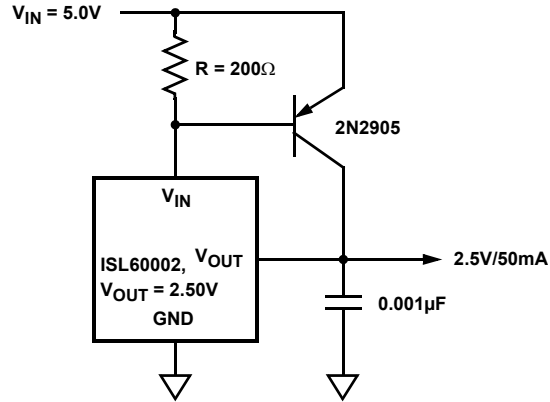

FIGURE 5. PRECISION 2.5V 50mA REFERENCE

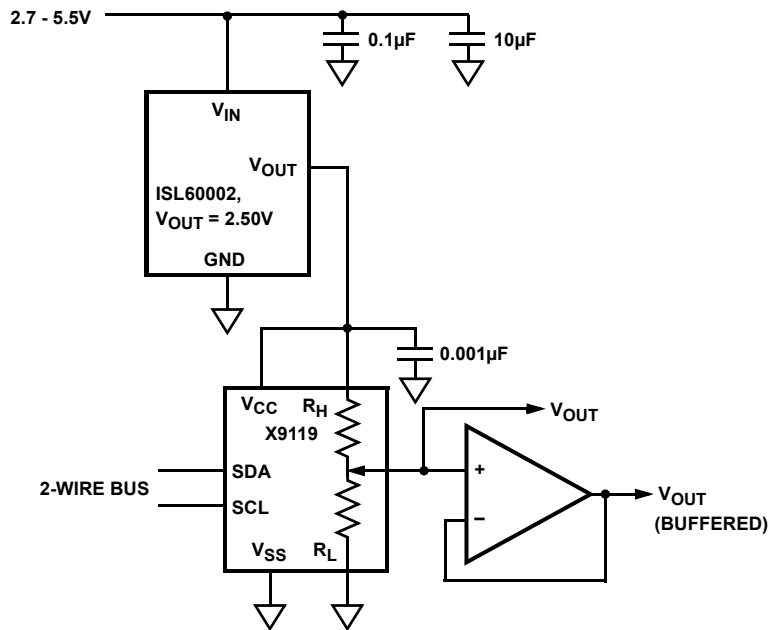

FIGURE 6. 2.5V FULL SCALE LOW-DRIFT 10-BIT ADJUSTABLE VOLTAGE SOURCE

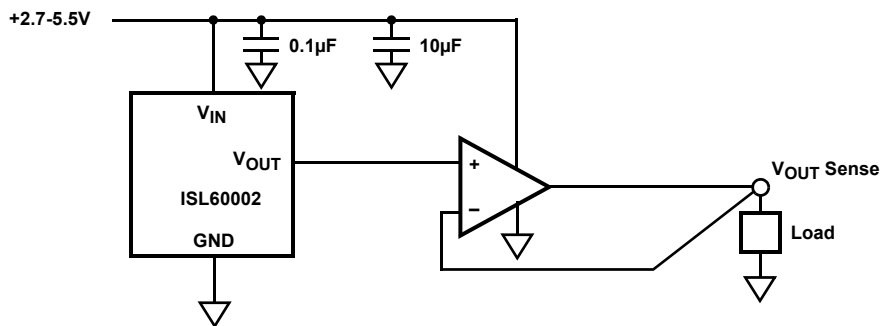
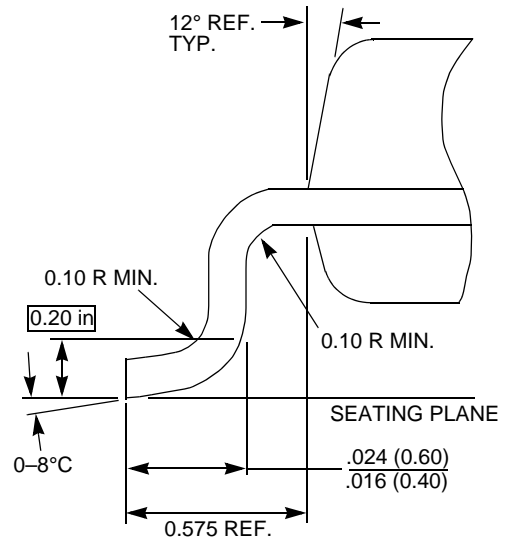
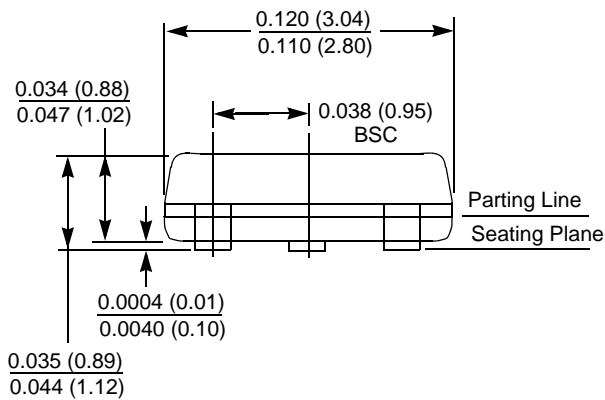
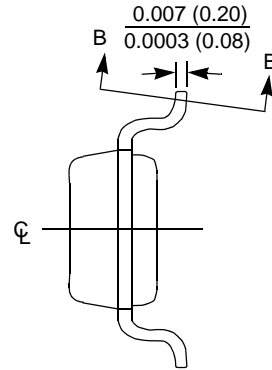
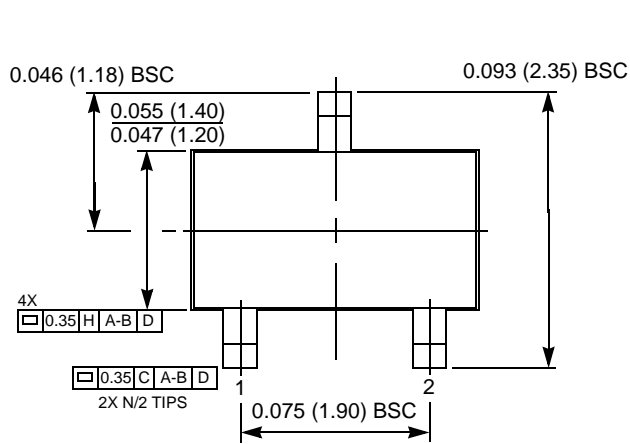

FIGURE 7. KELVIN SENSED LOAD

Packaging Information

3-Lead, SOT23, Package Code H3



NOTES:

1. All dimensions in inches (in parentheses in millimeters).
2. Package dimensions exclude molding flash.
3. Die and die paddle is facing down towards seating plane.
4. This part is compliant with JEDEC Specification TO-236AB.
5. Dimensioning and tolerances per ASME, Y14.5M-1994.

Packaging Information

8-Lead Plastic, SOIC, Package Code B8

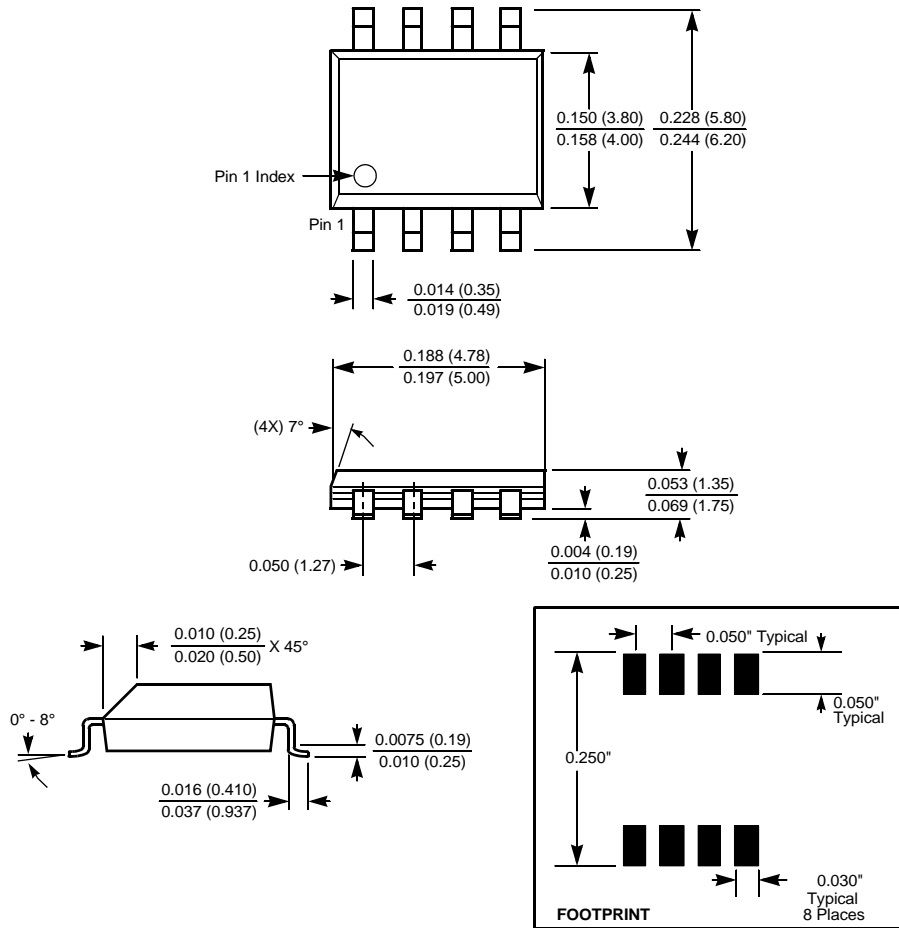

NOTE: All dimensions in inches (in parentheses in millimeters).

All Intersil U.S. products are manufactured, assembled and tested utilizing ISO9000 quality systems. Intersil Corporation's quality certifications can be viewed at [www.intersil.com/design/quality](http://www.intersil.com/design/quality)

*Intersil products are sold by description only. Intersil Corporation reserves the right to make changes in circuit design, software and/or specifications at any time without notice. Accordingly, the reader is cautioned to verify that data sheets are current before placing orders. Information furnished by Intersil is believed to be accurate and reliable. However, no responsibility is assumed by Intersil or its subsidiaries for its use; nor for any infringements of patents or other rights of third parties which may result from its use. No license is granted by implication or otherwise under any patent or patent rights of Intersil or its subsidiaries.*

For information regarding Intersil Corporation and its products, see [www.intersil.com](http://www.intersil.com)