

REVISIONS					
P	LTR	DESCRIPTION	DATE	DMN	APVD
AD	REVISED PER	ECO-20-000269	1-7-19	CT	DM

- THIS PLUG WILL MATE WITH ANY 11C1, SIZE 2 RECEPTACLE IN AMPLIMITE SERIES.
- MAXIMUM WIRE INSULATION TO BE USED WITH THIS PLUG IS  $\phi.068$ .
- THIS CONNECTOR ACCEPTS (1) POWER 8, OR COAX PIN CONTACT IN POSITIONS A1, PURCHASED SEPARATELY.
- THIS CONNECTOR ACCEPTS SIZE 20 PIN CONTACTS IN POSITIONS 1 THRU 32. PURCHASED SEPARATELY.
- STEEL PER ASTM-A-109.
- BRASS PER MIL-C-50 AND ASTM-B-36 UNS NO. C26000.
- CADMIUM PLATED PER QQ-P-416.
- GOLD PLATED PER MIL-G-45204 TYPE II, GRADE C, CLASS 1 OVER COPPER PER MIL-C-14550, CLASS IV.
- FINISH: TIN PER ASTM-B-545 .000400 MIN THK OVER COPPER PER AMS2418 .000050 MIN THK.
- FRONT SHELL HAS GROUNDING INDENTS FOR 211111-4, 211111-6, & 5-211111-4 ONLY.
- FINISH: ZINC PLATE PER ASTM-B-633 .000200-.000400 THK WITH SUPPLEMENTARY CHROMATE (Cr3+).

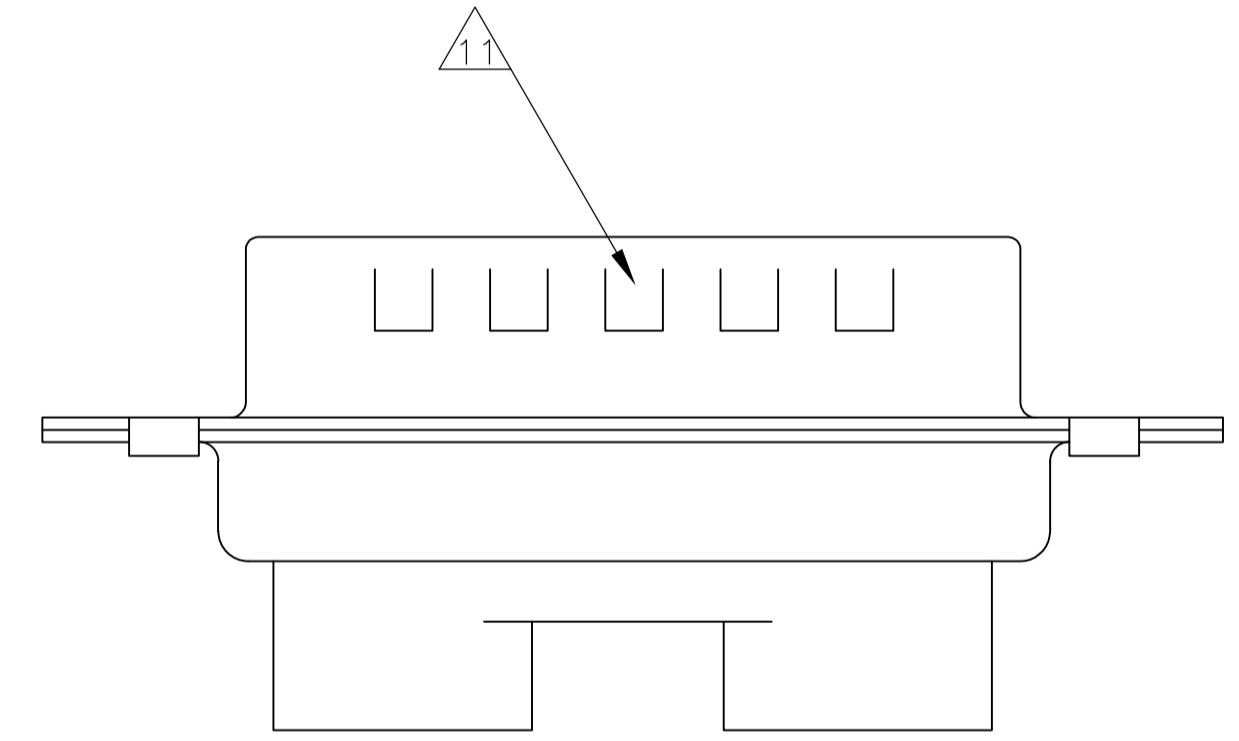
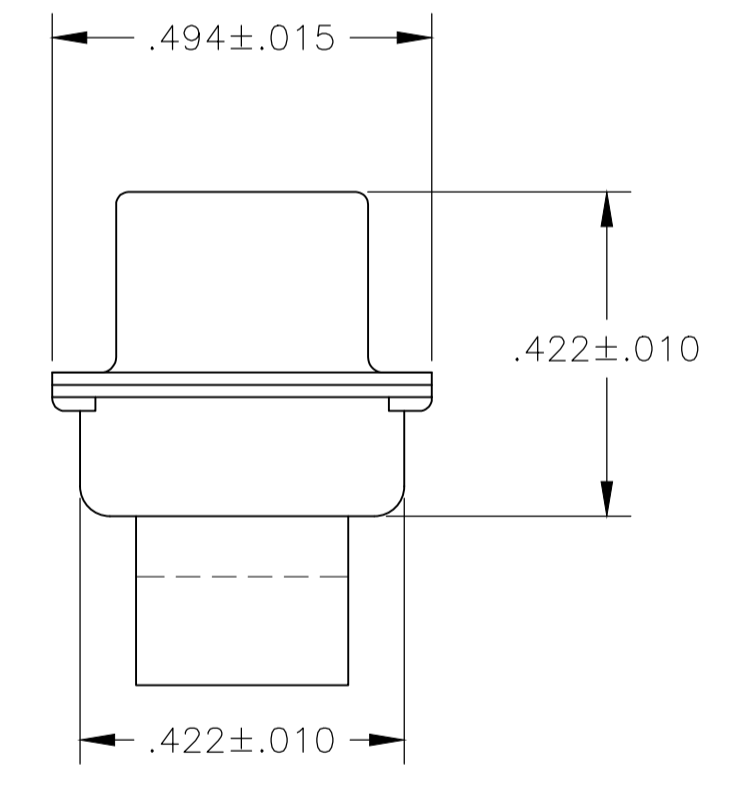
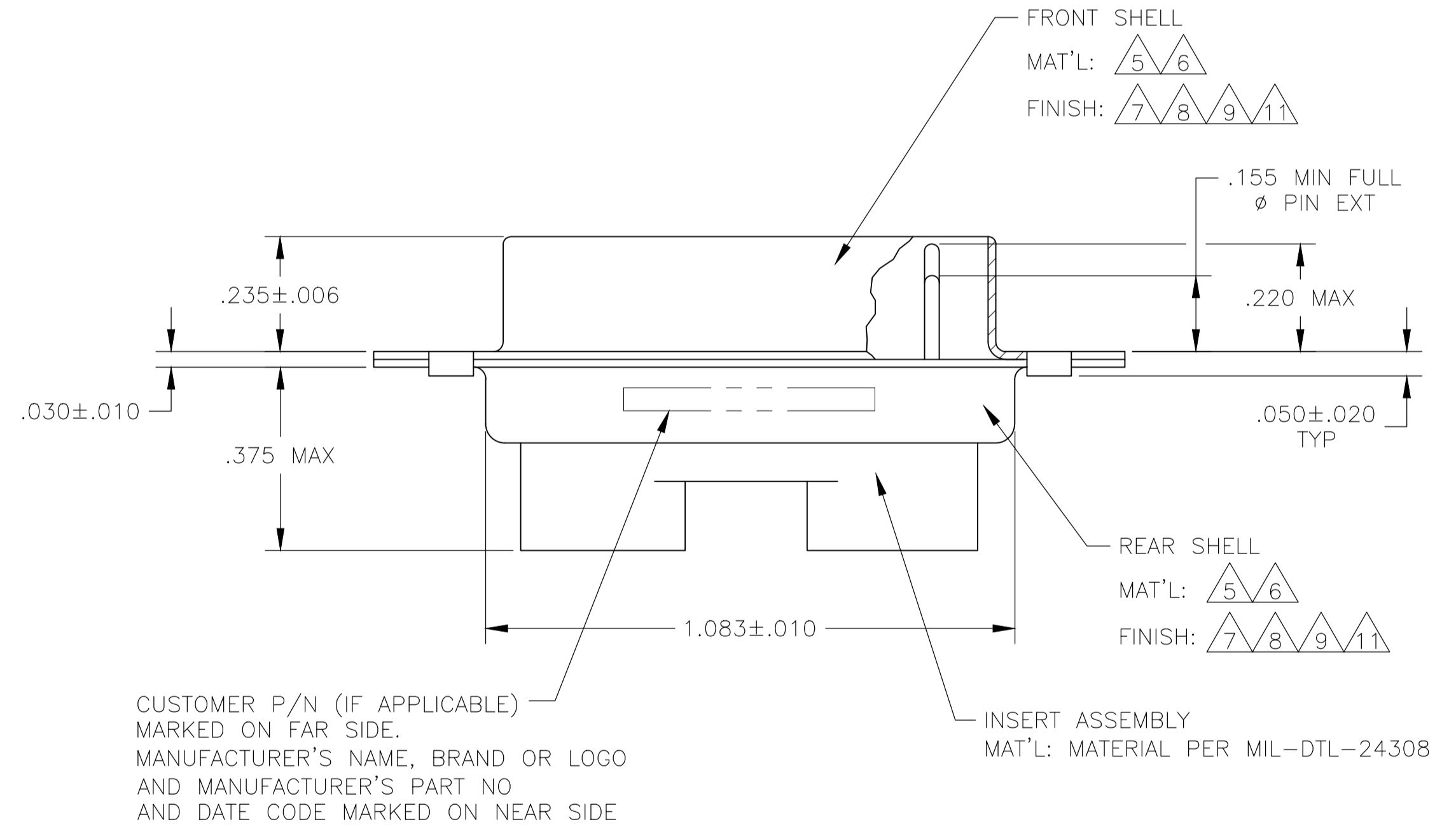
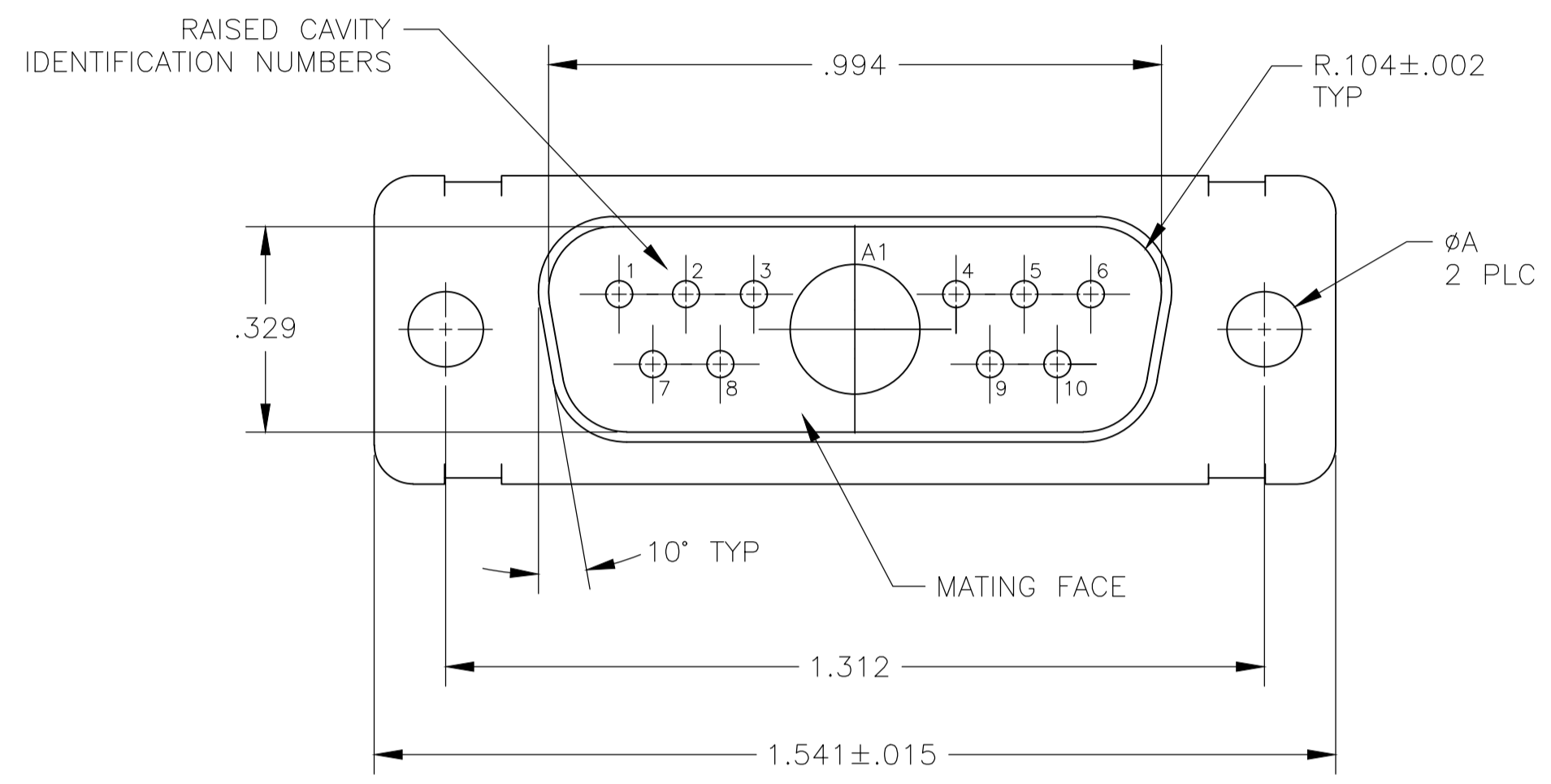

$\triangle 5 \triangle 10 \triangle 9$	.120	-	5-211111-4
$\triangle 5 \triangle 11$	.120	-	5-211111-1
$\triangle 5 \triangle 9$	.120	-	211111-7
$\triangle 5 \triangle 10 \triangle 9$	.120	-	211111-6
$\triangle 6 \triangle 8$	.120	B010942-0037	211111-5
$\triangle 5 \triangle 9 \triangle 10$	.120	-	211111-4
$\triangle 6 \triangle 8$	.154	311P405-9P-B-15	211111-3
$\triangle 6 \triangle 8$	.120	311P405-9P-B-12	211111-2
$\triangle 5 \triangle 7$	.120	-	211111-1
REMARKS	$\phi A$	CUSTOMER PART NO.	MFG'S PART NO.

THIS DRAWING IS A CONTROLLED DOCUMENT.

DIMENSIONS: INCHES	TOLERANCES UNLESS OTHERWISE SPECIFIED:	0 PLC ± -	1 PLC ± -	2 PLC ± -	3 PLC ± .005(0.13)	4 PLC ± -	ANGLES ± # 0°30'				
MATERIAL	FINISH	WEIGHT	0.000000	SIZE	A1	CAGE CODE	00779	DRAWING NO.	211111	RESTRICTED TO	-
CUSTOMER DRAWING		SCALE	4:1	SHEET	1	OF	1	REV	AD		

MANUNATH G. M. 27-May-15  
 CHARLES THOMAS 27-May-15  
 CHARLES THOMAS 27-May-15

**STE** TE Connectivity

PLUG ASSEMBLY  
 AMPLIMITE 11C1  
 SIZE 2, SERIES 109, COAX MIX