

REVISIONS

REV.	ECO	DESCRIPTION	DATE	APPROVED
U	44746	ITEM 12 WAS 51704-025	31MAY2001	CC

B-394

CONTACTOR-3PDT SIDE STABLE;
250 AMPS, 115/200V. 400 HZ.

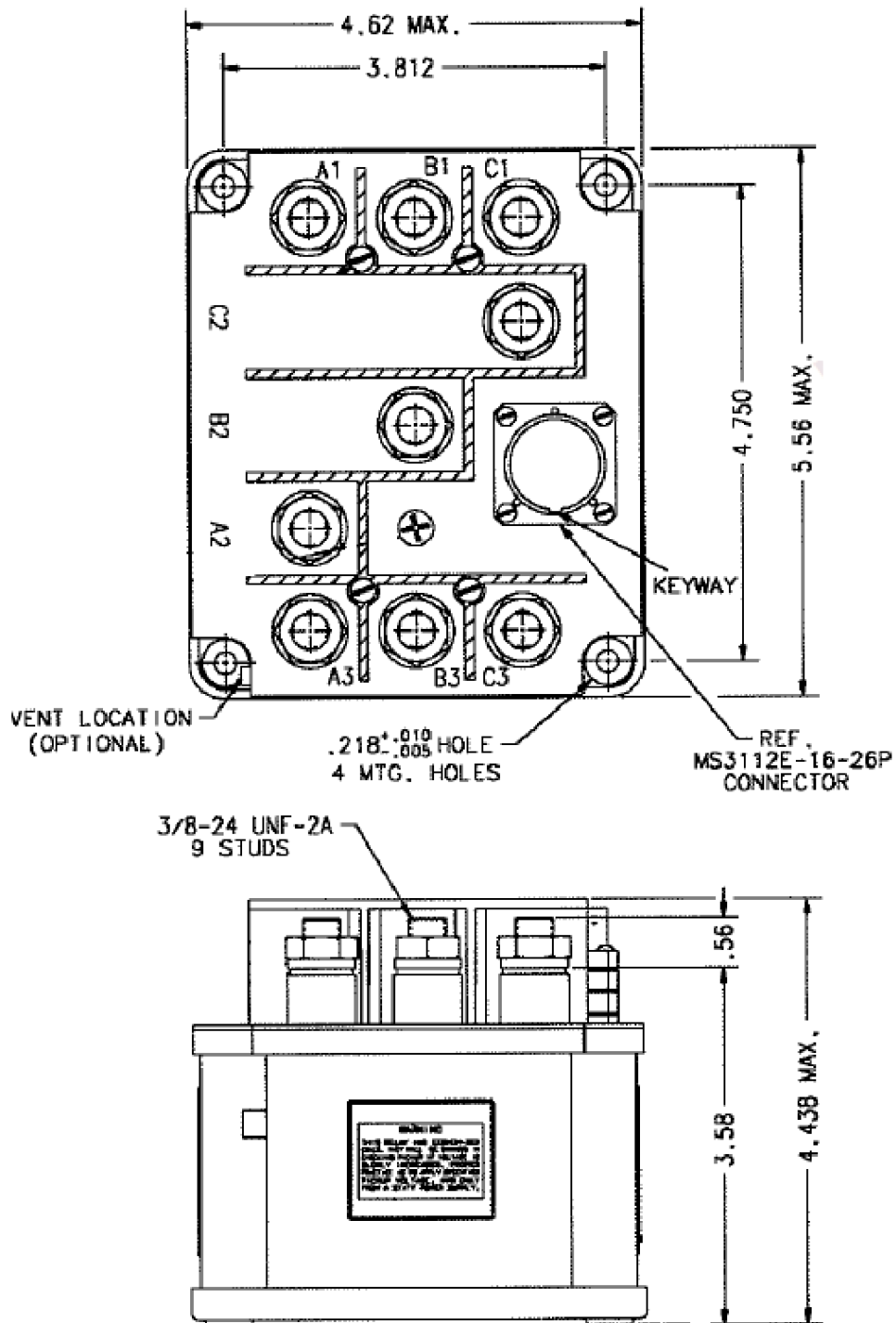

ALL DIMENSIONS ARE IN INCHES



TE CONNECTIVITY
175 N. DIAMOND STREET MANSFIELD,
OHIO 44902

TITLE

CONTACTOR-3PDT SIDE STABLE;
250 AMPS, 115/200V. 400 HZ.

TE P.N.

1616030-2

DWG NO.

B-394

DS DATA SHEET

CAGE CODE
74063

SCALE
NONE

SHEET
1 OF 2

REV
U

GENERAL SPECIFICATION

CONSTRUCTION

GASKET SEALED & VENTED

MAIN CONTACTS

CONFIGURATION 3PDT SIDE STABLE
 VOLTAGE 115/200 VAC 400HZ
 CURRENT: RES. 250 AMP
 IND. 250 AMP
 MOTOR 175 AMP

LIFE ELECTRICAL 50,000 CYCLES MIN.
 LIFE MECHANICAL 100,000 CYCLES MIN.
 MAX. WEIGHT 5 LBS. 8 OZ.
 OPERATING TIME 25MS MAX. AT 28 VDC 25°C
 RELEASE TIME 25MS MAX. AT 28 VDC 25°C
 CONTACT BOUNCE 3 MS MAX.

RUPTURE 2500 AMP

AUX. CONTACTS

CONFIGURATION 6PST NO 6PST NC
 VOLTAGE 28 VDC.
 CURRENT: RES. 5 AMP
 IND. 5 AMP
 LAMP 2 AMP

COIL DATA

DUTY CYCLE CONTINUOUS (ECONOMIZING)
 NOM. COIL VOLTAGE 18 TO 30 VDC
 PICKUP MAX. 18 VDC
 DROPOUT VOLTAGE 7 VOLTS TO 1 VOLT
 RESISTANCE HOLD 48.5±20% AT 25°C
 INRUSH 4.5 OHM±20% AT 25°C
 CURRENT HOLD 0.7 AMP MAX. AT 25°C
 INRUSH 6 AMP MAX. AT 25°C

ENVIRONMENTAL DATA

AMBIENT TEMP -70°C TO 71°C MAX
 VIBRATION .06 INCH DA FROM 5 TO 55 HZ
 10 G'S FROM 55 TO 500 HZ
 25 G'S FOR 6 TO 9 M SEC.
 SHOCK 15 G'S
 ACCELERATION
 ALTITUDE 50,000 FEET MAX.

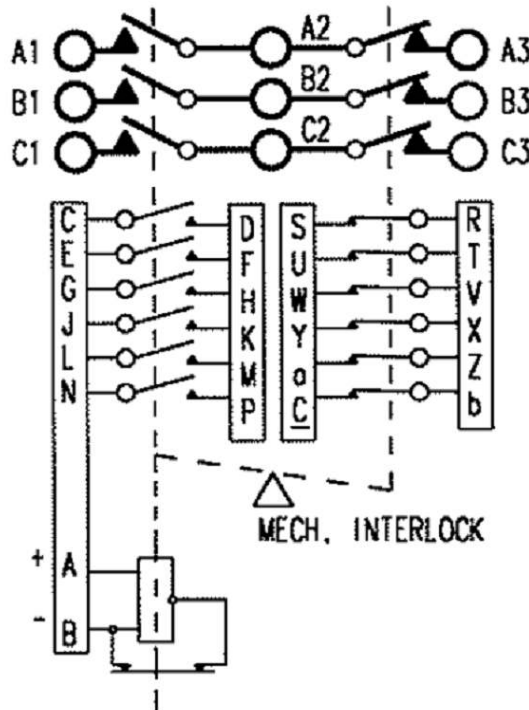

TE CONNECTIVITY
 175 N. DIAMOND STREET MANSFIELD,
 OHIO 44902

TITLE

CONTACTOR-3PDT SIDE STABLE;
 250 AMPS, 115/200V. 400HZ.

TE P.N.

1616030-2

DWG NO.

B-394

THIRD ANGLE PROJECTION

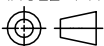

THIS DRAWING PREPARED
 IN ACCORDANCE WITH
 ANSI/ASMEY14.5M-1982

CAGE CODE

74063

SCALE

NONE

SHEET

2 OF 2

REV

U