

Features

- High DC Current Gain
- Complimentary to MMBT624

1. BASE
2. EMITTER
3. COLLECTOR

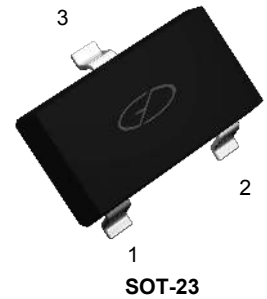

Absolute Maximum Ratings ($T_A=25^{\circ}\text{C}$ unless otherwise noted)

Parameter	Symbol	Rating	Unit
Collector-Base Voltage	V_{CB0}	30	V
Collector-Emitter Voltage	V_{CEO}	25	V
Emitter-Base Voltage	V_{EBO}	5	V
Collector Current	I_C	700	mA
Collector Power Dissipation	P_C	200	mW
Thermal Resistance from Junction to Ambient	$R_{\theta JA}$	625	$^{\circ}\text{C/W}$
Junction Temperature	T_J	-55 to +150	$^{\circ}\text{C}$
Storage Temperature	T_{stg}	-55 to +150	$^{\circ}\text{C}$

Electrical Characteristics ($T_A=25^{\circ}\text{C}$ unless otherwise noted)

Parameter	Symbol	Conditions	Min	Typ	Max	Unit
Collector-base Breakdown Voltage	$V_{(BR)CB0}$	$I_R=100\mu\text{A}, I_E=0$	30	--	--	V
Collector-emitter Breakdown Voltage	$V_{(BR)CEO}$	$I_C=1\text{mA}, I_B=0$	25	--	--	V
Emitter-base Breakdown Voltage	$V_{(BR)EBO}$	$I_E=100\mu\text{A}, I_C=0$	5	--	--	V
Collector Cut-off Current	I_{CB0}	$V_{CB}=30\text{V}, I_E=0$	--	--	0.1	μA
Emitter Cut-off Current	I_{EBO}	$V_{EB}=5\text{V}, I_C=0$	--	--	0.1	μA
DC Current Gain	$h_{FE(1)*}$	$C_E=1\text{V}, I_C=100\text{mA}$	110	--	400	--
	$h_{FE(2)*}$	$C_E=1\text{V}, I_C=700\text{mA}$	50	--	--	--
Collector-emitter Saturation Voltage	$V_{CE(sat)*}$	$C=700\text{mA}, I_B=70\text{mA}$	--	--	0.6	V
Base-emitter Voltage	V_{BE*}	$C_E=6\text{V}, I_C=10\text{mA}$	0.6	--	0.7	V
Tansition Frequency	f_T	$V_{CE}=6\text{V}, I_C=10\text{mA}$	170	--	--	MHz
Collector Output Capacitance	C_{ob}	$V_{CB}=6\text{V}, I_E=0, f=10\text{MHZ}$	--	12	--	pF

* Pulse test : Pulse width $\leq 350\mu\text{s}$, Duty Cycles $\leq 2\%$.

Classification of $h_{FE(1)}$

Marking	DV1	DV2	DV3	DV4	DV5
Range	110-180	135-220	170-270	200-320	250-400

Typical Characteristic Curves

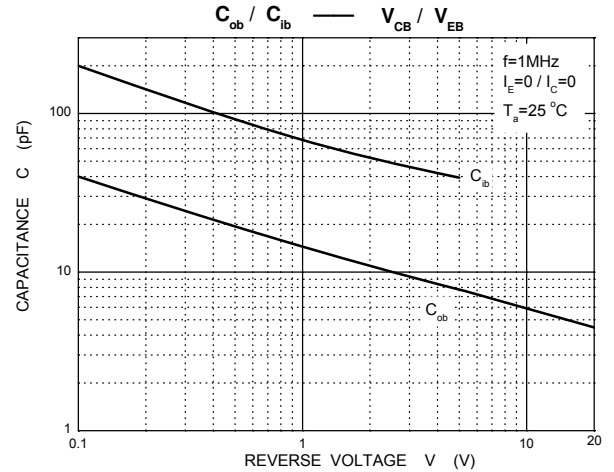
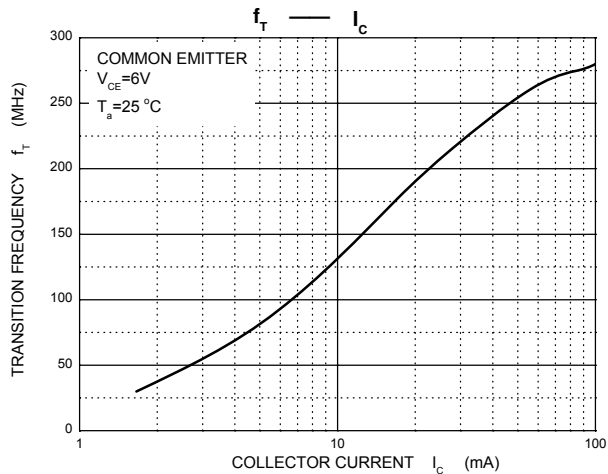
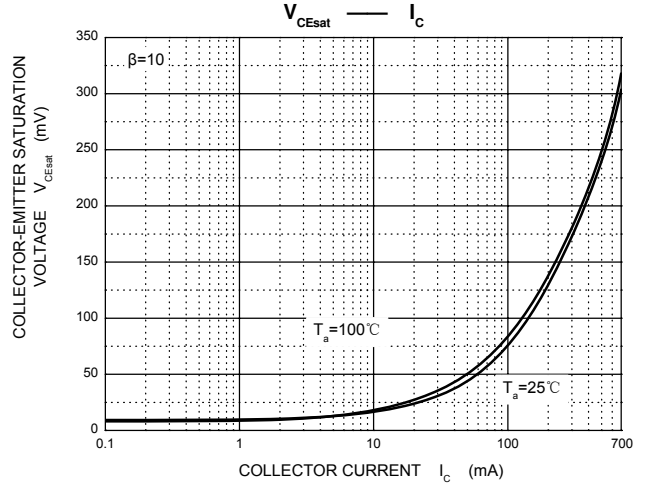
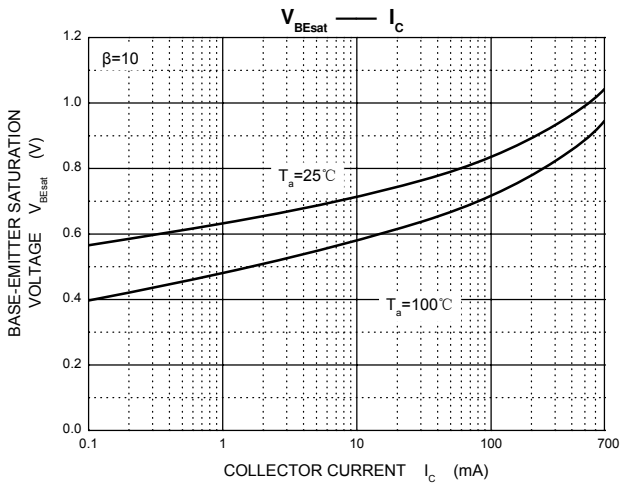
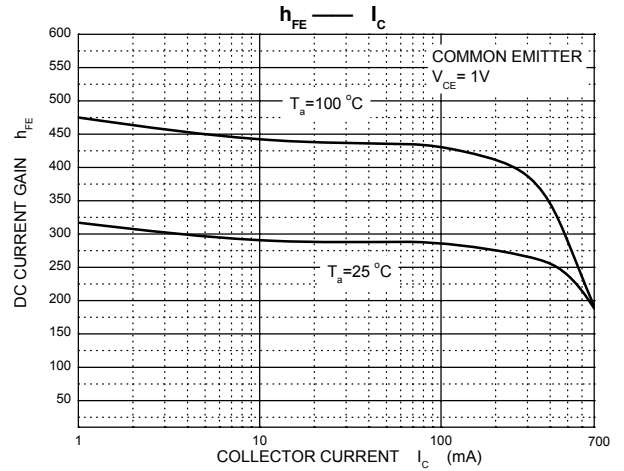
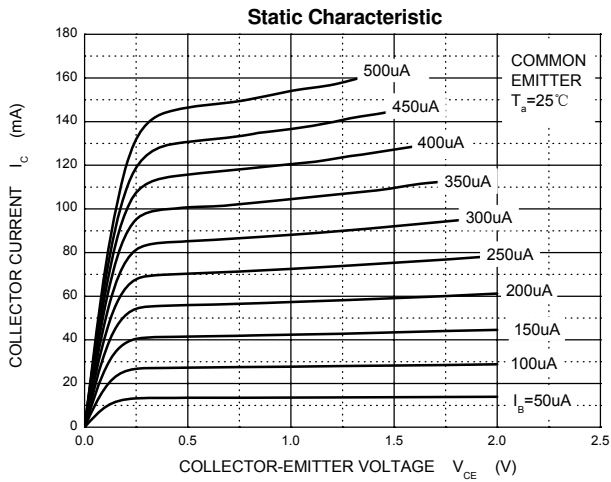

Typical Characteristic Curves

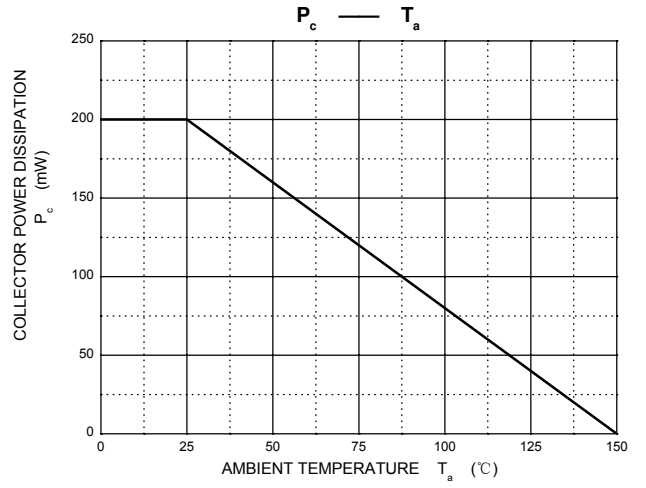
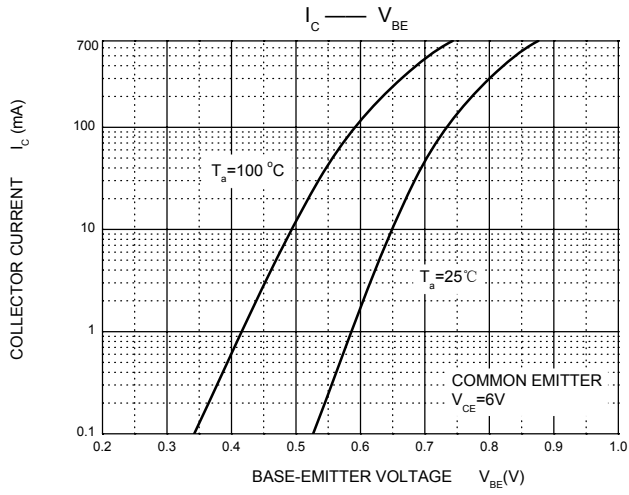

Package Outline Dimensions SOT-23

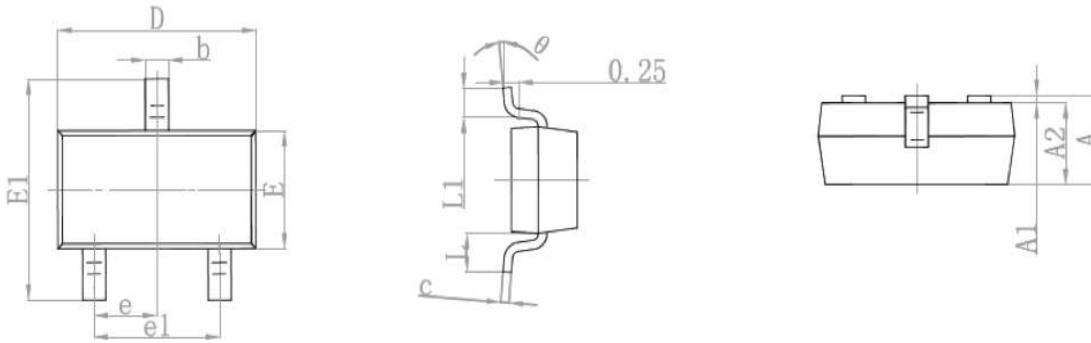

Symbol	Dimensions In Millimeters		Dimensions In Inches	
	Min	Max	Min	Max
A	0.900	1.150	0.035	0.045
A1	0.000	0.100	0.000	0.004
A2	0.900	1.050	0.035	0.041
b	0.300	0.500	0.012	0.020
c	0.080	0.150	0.003	0.006
D	2.800	3.000	0.110	0.118
E	1.200	1.400	0.047	0.055
E1	2.250	2.550	0.089	0.100
e	0.950 TYP		0.037 TYP	
e1	1.800	2.000	0.071	0.079
L	0.550 REF		0.022 REF	
L1	0.300	0.500	0.012	0.020
θ	0°	8°	0°	8°

Recommended Pad Layout

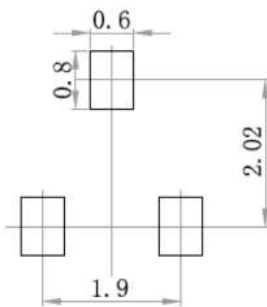

- Note:
1. Controlling dimension: in millimeters.
 2. General tolerance: $\pm 0.05\text{mm}$.
 3. The pad layout is for reference purposes only.