

EasyPIC™ v7

for dsPIC30®

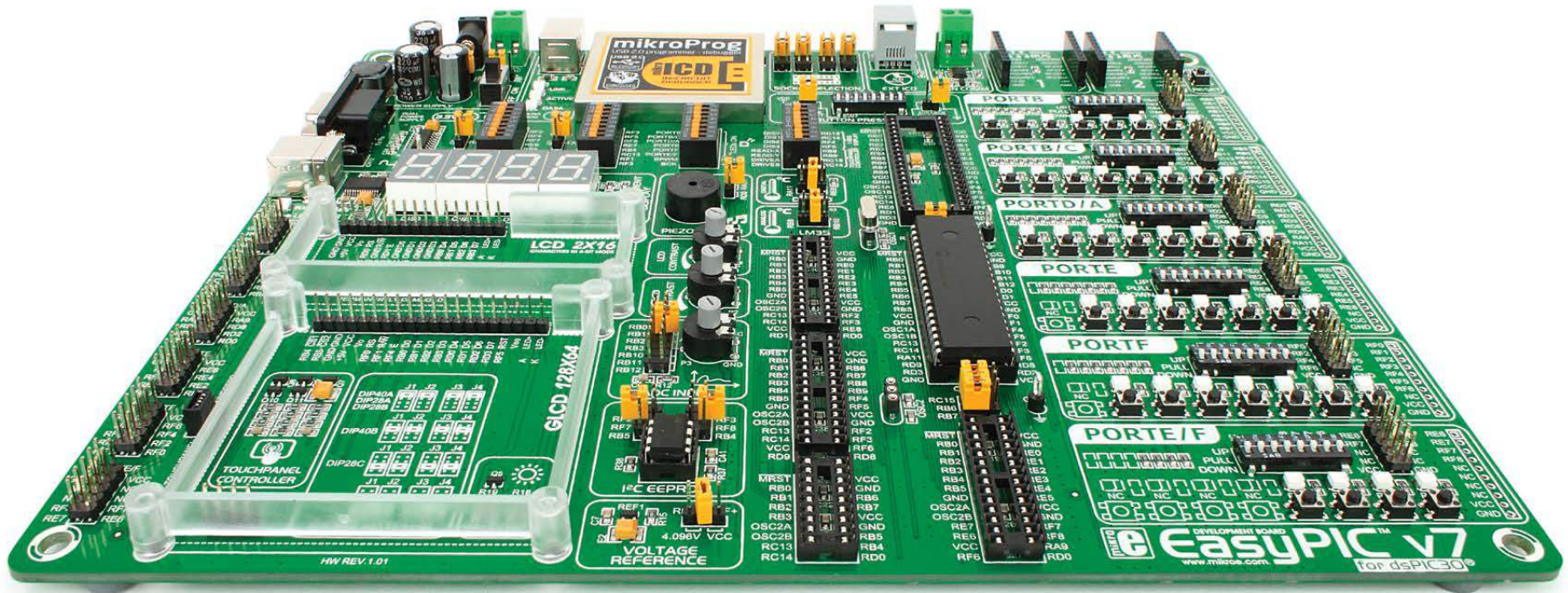

dsPIC30®

14 microcontrollers supported
dsPIC30® in DIP package

DUAL POWER SUPPLY



Supports 3.3V and 5V devices
Dual Power Supply



Easily add extra boards
mikroBUS™ sockets

connectivity



Four connectors for each port
Amazing Connectivity



Fast USB 2.0 programmer and
In-Circuit Debugger

To our valued customers

From the day one, we in MikroElektronika gave ourselves the highest possible goals in pursuit of excellence. That same day, the idea of EasyPIC™ development board was born. In its each and tiniest piece we had put all of our energy, creativity and sense of what's best for an engineer.

Today, we present you the 7th generation of our boards, which brings us some exciting new features. We hope that you will like it as much as we do.

Use it wisely and have fun!

A handwritten signature in blue ink, appearing to read 'Nebojsa Matic', with a stylized, cursive style.

Nebojsa Matic,
Owner and General Manager
of MikroElektronika

Table of contents

Introduction

Introduction	04
It's good to know	05

Power Supply

Dual power supply	06
-------------------------	----

Supported MCUs

Supported microcontrollers	08
----------------------------------	----

Programming

On-board programmer	10
Installing programmer drivers	12
Programming software	13
mikroLCD™ - In Circuit Debugger	14

Communication

UART via RS-232	16
UART via USB	17
CAN communication	18

Connectivity

mikroBUS™ sockets	19
Input/Output Group	22

Displays

LCD 2x16 characters	24
GLCD 128x64px	25
Touch panel controller	26
4 digit 7-seg display	27

Other Modules

DS1820 - Digital Temperature Sensor	28
LM35 - Analog Temperature Sensor	29
ADC inputs	30
I ² C EEPROM	31
Piezo Buzzer	32
Additional GNDs	33

What's Next

What's Next?	34
--------------------	----

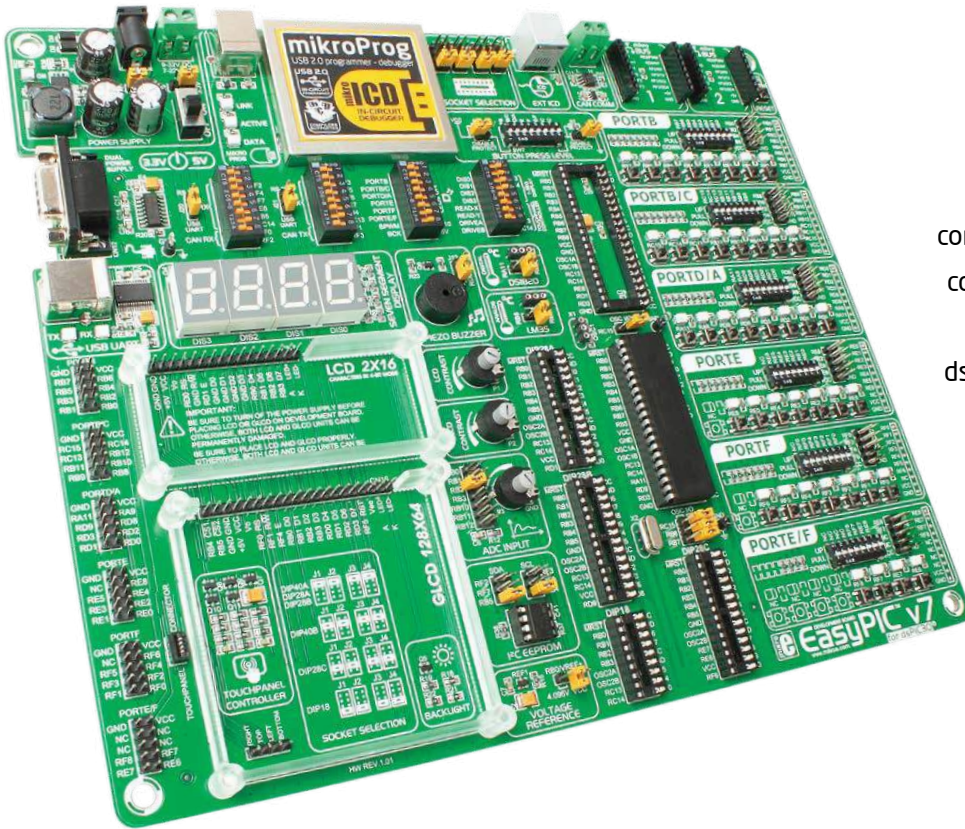

Introduction

dsPIC30F® microcontrollers are 16-bit high-performance digital signal controllers suitable for advanced motor control algorithms, digital power converters, speech and audio applications. We realized that benefit and start to develop a new system which is convenient for wide range of dsPIC30F® microcontroller family produced in DIP packages. We focused all of our creativity and knowledge into making a revolutionary new design which covers many internal modules. Finally, we present you the EasyPIC™ v7 for dsPIC30® board which is powerful, well organized, with on-board programmer and debugger. Board is suitable for students, hobbyists, enthusiasts and professionals.

We hope you will enjoy it as much as we do.

EasyPIC™ v7 for dsPIC30® development Team

Four Connectors for each port Amazing connectivity

EasyPIC™ v7 for dsPIC30® is all about connectivity. Having three different connectors for each port, you can connect accessory boards, sensors and your custom electronics easier than ever before.



Everything is already here mikroProg™ on board

Powerful on-board mikroProg™ programmer and In-Circuit debugger can program and debug 14 dsPIC30® microcontrollers. You will need it, whether you are a professional or a beginner.



3.3V and 5V power supply Dual Power Supply

EasyPIC™ v7 for dsPIC30® is among few development boards which support both 3.3V and 5V power supply. This feature allows you to use the microcontrollers with both power supply. It's like having two boards instead of one!

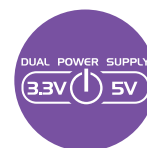

For easier connections mikroBUS™ support

Just plug in your Click™ board, and it's ready to work. We picked up a set of the most useful pins you need for development and made a pinout standard you will enjoy using.



It's good to know

dsPIC30F4013 is the default microcontroller!

dsPIC30F4013 is the default chip of EasyPIC™ v7 for dsPIC30®. It has **30 MIPS** operation, **48K bytes** of program memory, **2048 bytes** of SRAM memory, **1024 bytes** of EEPROM memory. It has 24-bit wide instructions and 16-bit wide data path. It's loaded with great modules: 30 General purpose **I/O pins**, 12-bit Analog-to-Digital with up to 13 channels (**ADC**), 5x16-bit and 2x32-bit timers, 2x**UART**, 1x**SPI**, 1x**I²C**, 1x**CAN**, 16-bit compare/PWM output functions. It has two 40-bit wide accumulators with optional saturation logic, 17-bit x 17-bit single hardware fractional/integer cycle multiplier and all DSP instructions are single cycle.

- Great choice for both beginners and professionals
- Rich with modules
- Enough RAM and Flash
- Comes with examples for mikroC, mikroBasic and mikroPascal compilers



System Specification



power supply
7-23V AC or 9-32V DC
or via USB cable (5V DC)



power consumption
~99mA when all peripheral
modules are disconnected

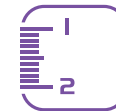

board dimensions
266 x 220mm (10.47 x 8.66 inch)



weight
~445g (0.981 lbs)

Package contains



1 Damage resistant protective box



2 EasyPIC™ v7 for dsPIC30® board in antistatic bag



3 USB cable



4 User Manuals and Board schematics

Dual power supply

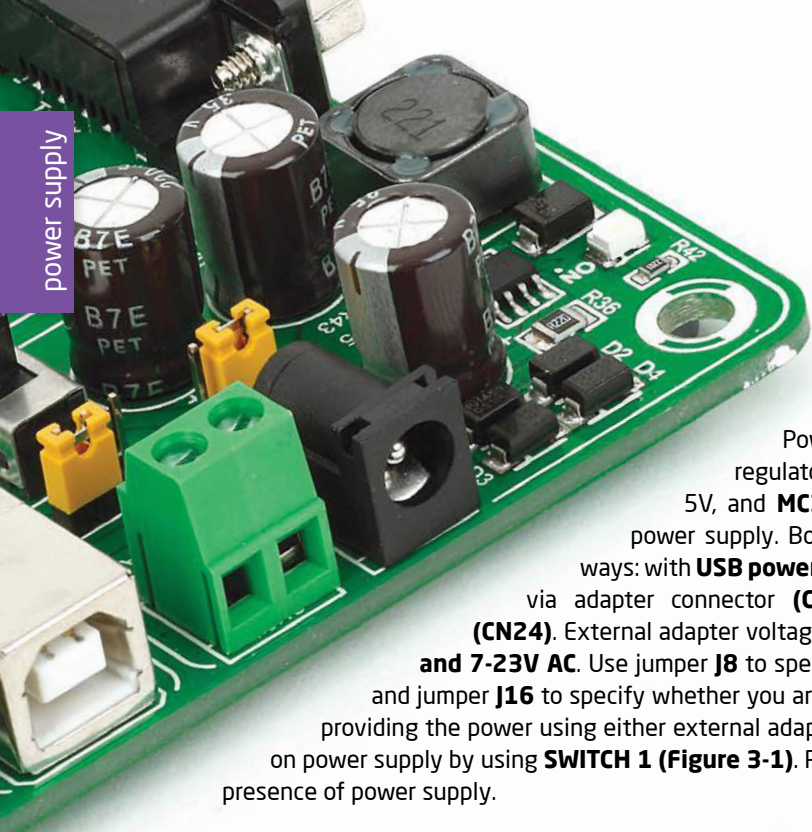

Board contains switching power supply that creates stable voltage and current levels necessary for powering each part of the board. Power supply section contains two power regulators: **MC34063A**, which generates VCC-5V, and **MC33269DT3.3** which creates VCC-3.3V power supply. Board can be powered in three different ways: with **USB power supply (CN1)**, using external adapters via adapter connector (**CN25**) or additional screw terminals (**CN24**). External adapter voltage levels must be in range of **9-32V DC and 7-23V AC**. Use jumper **J8** to specify which power source you are using, and jumper **J16** to specify whether you are using 5V or 3.3V power supply. Upon providing the power using either external adapter, or USB power source, you can turn on power supply by using **SWITCH 1 (Figure 3-1)**. Power **LED (Green ON)** will indicate the presence of power supply.

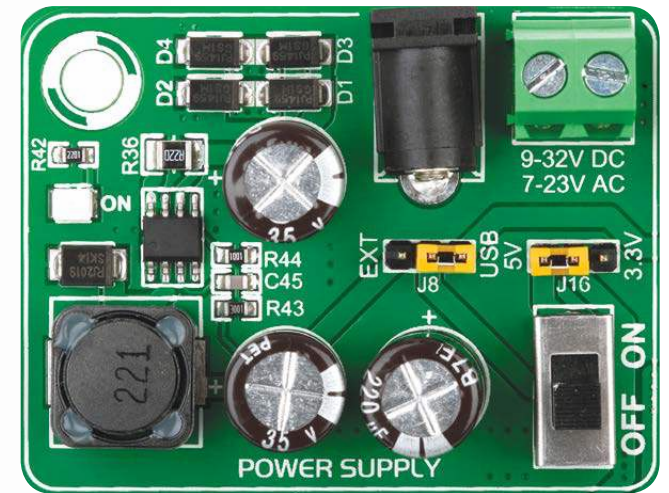

Figure 3-1: Power supply unit of EasyPIC™ v7 for dsPIC30®

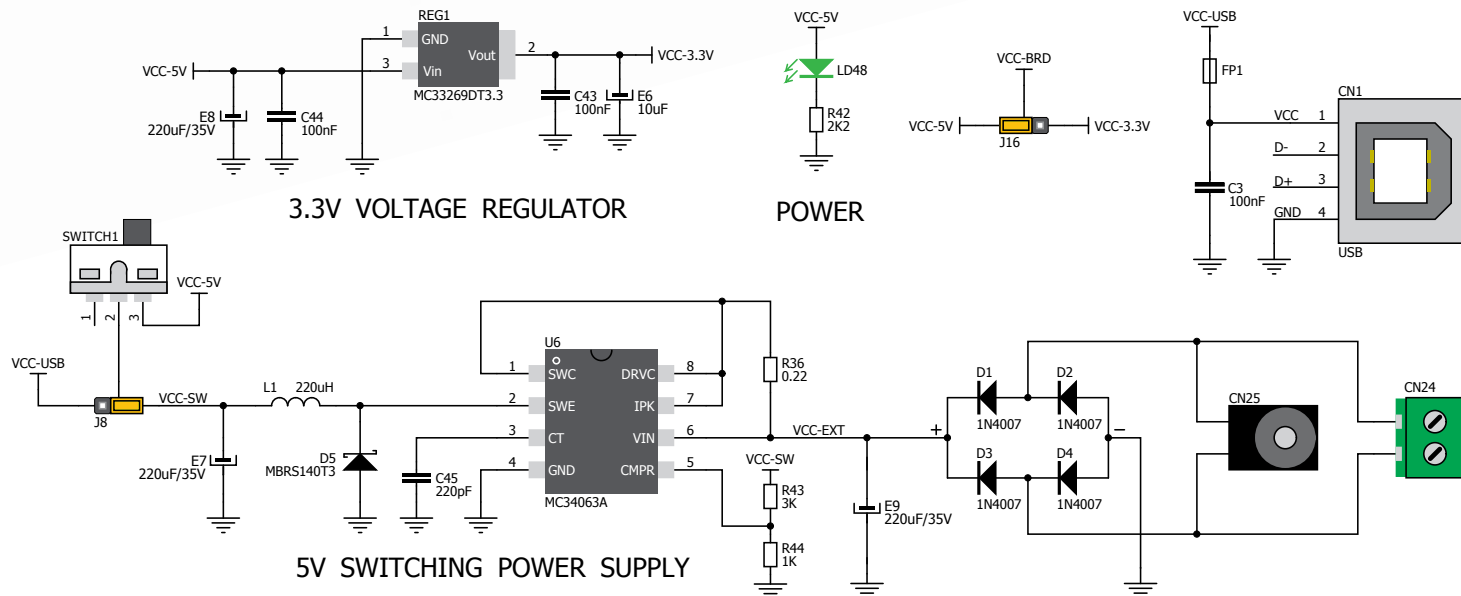

Figure 3-2: Dual power supply unit schematics

DUAL POWER SUPPLY



EasyPIC™ v7 for dsPIC30® development board supports both 3.3V and 5V power supply on a single board. This feature enables you to use wide range of peripheral boards.

Power supply:

via DC connector or screw terminals (7V to 23V AC or 9V to 32V DC), or via USB cable (5V DC)

Power capacity:

up to 500mA with USB, and up to 600mA with external power supply

How to power the board?

1. With USB cable



Set J8 jumper to USB position

To power the board with USB cable, place jumper **J8** in USB position, and place jumper **J16** in 5V or 3.3V position. You can then plug in the USB cable as shown on images **1** and **2**, and turn the power switch ON.



2. Using adapter



Set J8 jumper to EXT position

To power the board via adapter connector, place jumper **J8** in EXT position, and place jumper **J16** in 5V or 3.3V position. You can then plug in the adapter cable as shown on images **3** and **4**, and turn the power switch ON.

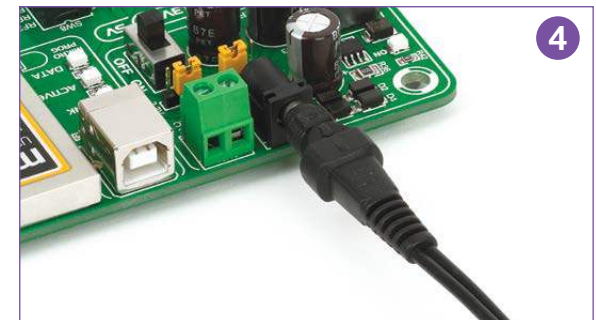

3. With laboratory power supply



Set J8 jumper to EXT position

To power the board using screw terminals, place jumper **J8** in EXT position, and place jumper **J16** in 5V or 3.3V position. You can then screw-on the cables in the screw terminals as shown on images **5** and **6**, and turn the power switch ON.

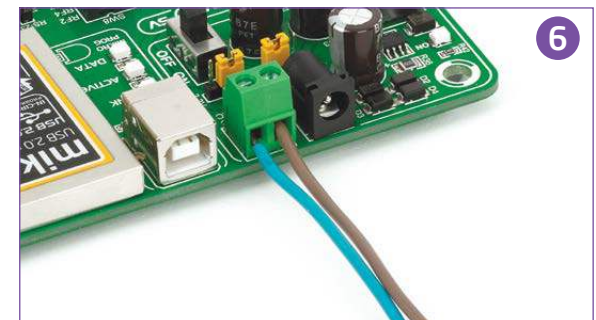
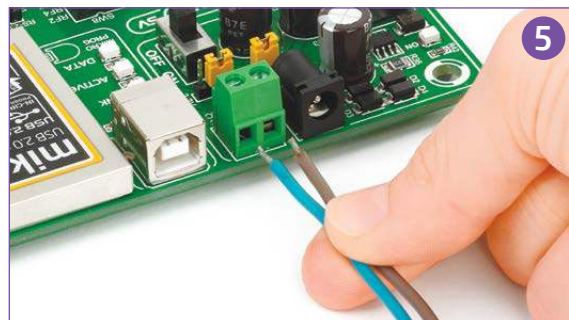

Supported microcontrollers

Board contains six DIP sockets: DIP40A, DIP40B, DIP28A, DIP28B, DIP28C, DIP18. With dual power supply and smart on-board mikroProg, board is capable of programming and debugging 14 different microcontrollers from dsPIC30F® family.

There are two DIP40, three DIP28 and one DIP18 socket for dsPIC30F® microcontrollers provided on the board. Which of these sockets you will use depends solely on the pinout of the microcontroller in use. The **EasyPIC™ v7 for dsPIC30F** development system comes with the **dsPIC30F4013** microcontroller in a **DIP40** package (pinout corresponds to **DIP40B** socket). In order for microcontrollers to have a stable operation, we provided decoupling capacitive filters on every board socket, **Figure 4-1**.

Which socket to use?

Supported microcontrollers come in different DIP packages (DIP40, DIP28 and DIP18) and with different pinout. That is why you need to put chosen microcontroller in appropriate socket. Here is the list of supported microcontrollers with DIP sockets:

DIP40A	dsPIC30F3011, dsPIC30F4011
DIP40B	dsPIC30F3014, dsPIC30F4013 (default chip)
DIP28A	dsPIC30F2010, dsPIC30F3010, dsPIC30F4012
DIP28B	dsPIC30F2012, dsPIC30F3013
DIP28C	dsPIC30F1010, dsPIC30F2020
DIP18	dsPIC30F2011, dsPIC30F3012

(see figure 4-1)

Figure 4-1: Schematics of on-board DIP sockets and decoupling capacitors

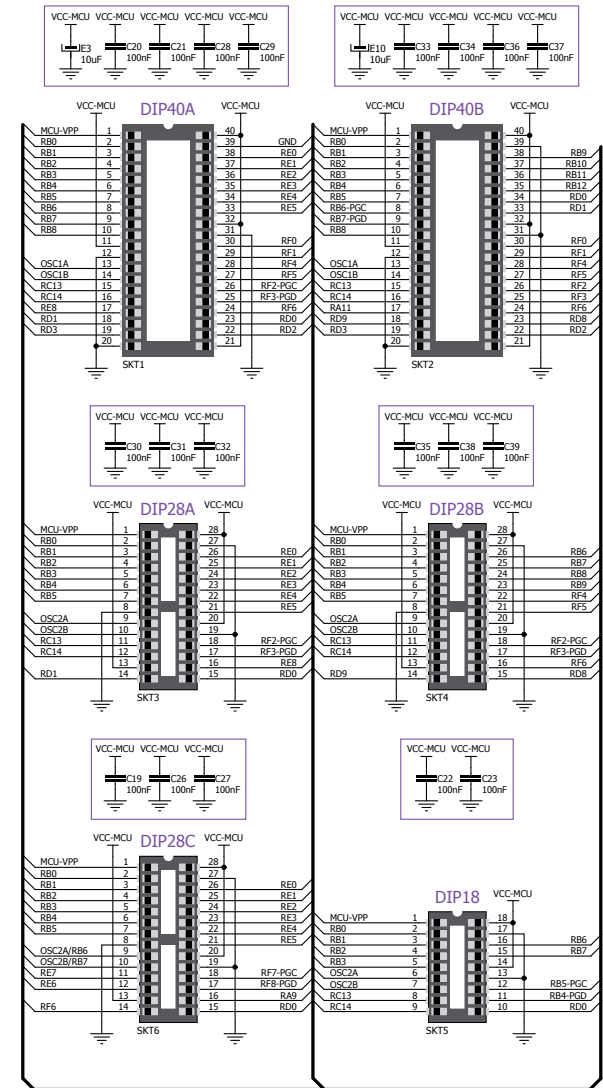
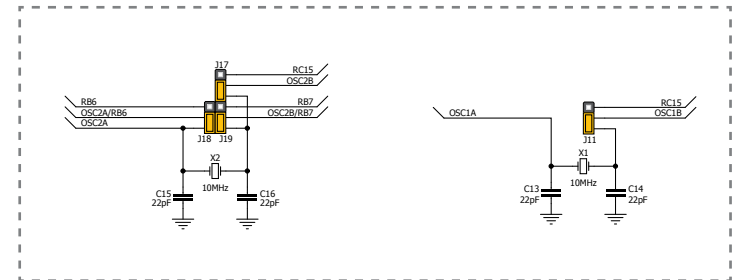

Figure 4-2: crystal oscillators



How to properly place your microcontroller into the DIP socket?

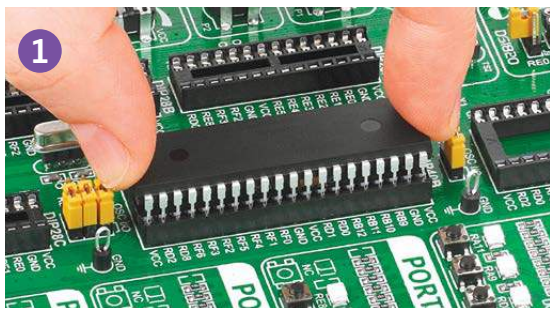

Figure 4-3: Place both ends of microcontroller on the socket so the pins are aligned correctly

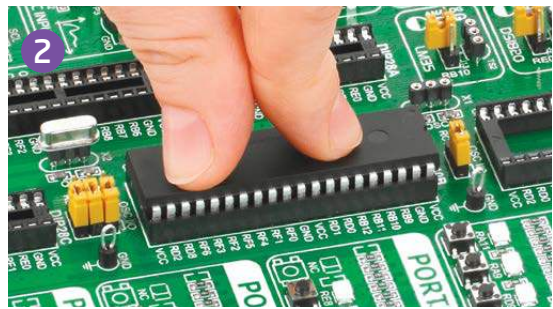

Figure 4-4: with both fingers, evenly distribute the force and press the chip into the socket.



Figure 4-5: Properly placed microcontroller will have equally leveled pins.

Before you plug the microcontroller into the appropriate socket, make sure that the **power supply is turned off**. Images above show how to correctly plug a microcontroller. First make sure that

a half circular cut in the microcontroller DIP packaging matches the cut in the DIP socket. Place both ends of the microcontroller into the socket as shown in **Figure 4-3**. Then put the microcontroller slowly down until

all the pins match the socket as shown in **Figure 4-4**. Check again if everything is placed correctly and press the microcontroller until it is completely plugged into the socket as shown in **Figure 4-5**.

IMPORTANT: *Only one microcontroller may be plugged into the development board at the same time.*

Using crystal oscillators



Figure 4-6: RC15 as I/O pin (when using internal oscillator)

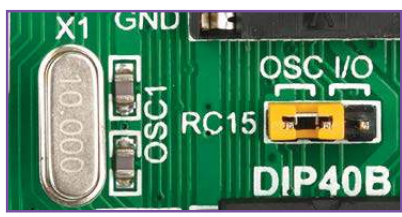

Figure 4-7: RC15 connected to X1 quartz-crystal

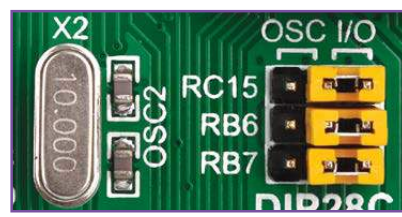

Figure 4-8: RC15, RB6 and RB7 as I/O pins (when using internal oscillator)

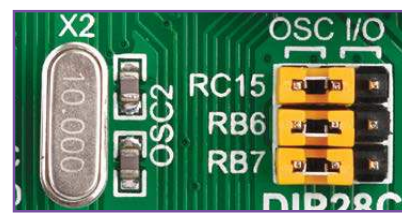

Figure 4-9: RC15, RB6 and RB7 connected to X2 quartz-crystal

PIC microcontrollers normally use a quartz crystal for the purpose of providing clock frequency. The **EasyPIC™ v7 for dsPIC30®** provides two sockets for quartz-crystal. Microcontrollers in **DIP40A** and **DIP40B** packages use socket **X1 (OSC1)** for quartz-crystal.

If you want to use microcontrollers in **DIP28A, DIP28B, DIP28C** and **DIP18** packages, it is necessary to put quartz crystal into socket **X2 (OSC2)**. The value of the crystal depends on the maximum clock frequency allowed and your application. You can always exchange the default 10MHz crystal with another one.

On-board programmer



What is mikroProg™?

mikroProg™ is a fast USB 2.0 programmer with mikroICD™ hardware In-Circuit Debugger. Smart engineering allows mikroProg™ to support all dsPIC30® DIP microcontrollers from Microchip® in a single programmer. Outstanding performance and easy operation are among its top features.

How do I start?

In order to start using mikroProg™ and program your microcontroller, you just have to follow two simple steps:

1. Install the necessary software

- Install USB drivers
- Install mikroProg Suite™ for PIC® software

2. Power up the board, and you are ready to go.

- Plug in the programmer USB cable
- LINK LED should light up.

Socket selection

Jumpers **J1**, **J2**, **J3** and **J4** are used to select **PGC** and **PGD** programming lines for your microcontroller. Make sure to place jumpers in the proper position for your socket.

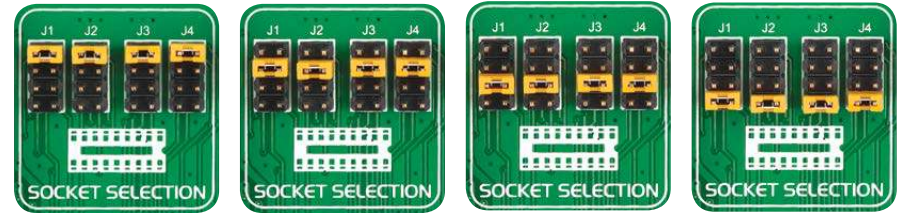

DIP40A
DIP28A
DIP28B

DIP40B

DIP28C

DIP18

Why so many LEDs?

Three LEDs indicate specific programmer operation. **Link** LED lights up when USB link is established with your PC, **Active** LED lights up when programmer is active. **Data** is on when data is being transferred between the programmer and PC software (compiler or mikroProg Suite™ for PIC®).



IMPORTANT - Programming/Debugging mode raises MCU voltage to 5V!

When on-board mikroProg™ programmer is in programming/debugging mode, it automatically raises the MCU voltage to 5V regardless of the power supply selection (jumper J16). Note that all external peripherals that can only work on 3.3V must be removed from the board when programming/debugging is in progress, otherwise they can be permanently damaged. When programming/debugging is not in progress (execute mode or release mode) you can connect both 3.3V or 5V peripherals to the board depending on the position of jumper J16.

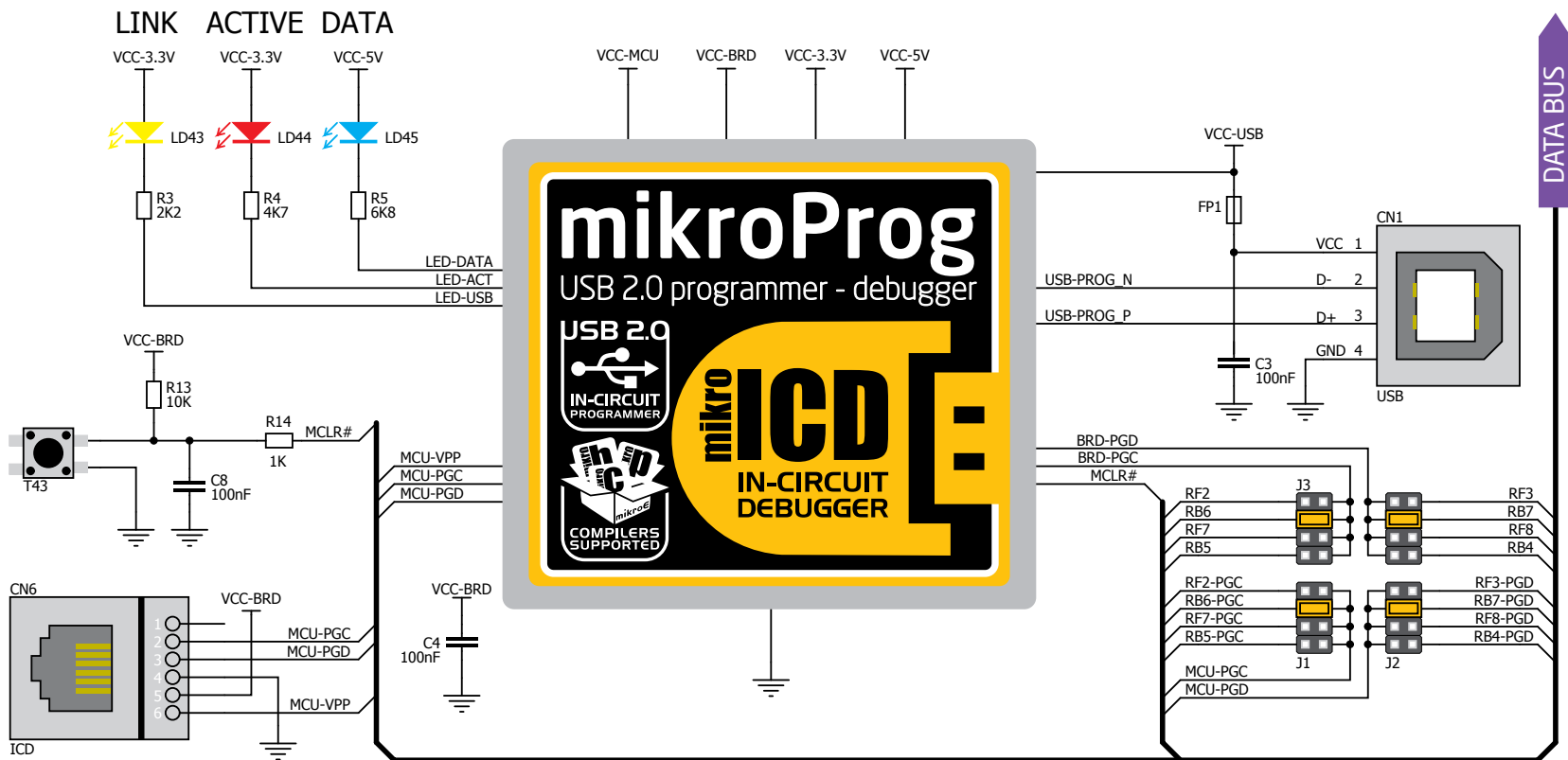
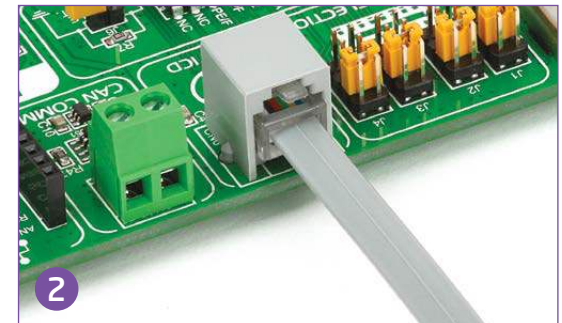
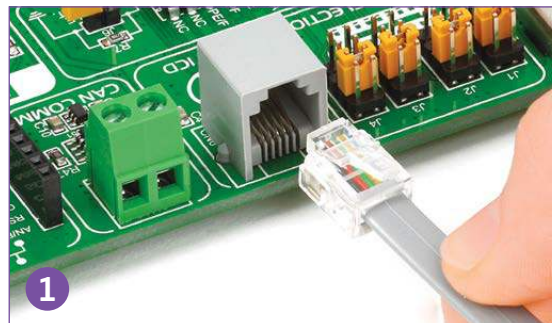



Figure 5-1: mikroProg™ block schematics

Programming with ICD2/ICD3

EasyPIC™ v7 for dsPIC30® is equipped with RJ-12 connector compatible with Microchip® ICD2® and ICD3® external programmers. You can either use the on-board mikroProg™ programmer or external programming tools with the board as long as you use only one of them at the same time. Still you have to **set the appropriate jumpers**, as described in the previous page. Insert your ICD programmer cable into connector **CN6**, as shown in images **1** and **2**.



Installing programmer drivers

On-board mikroProg™ requires drivers in order to work. Drivers are located on the  that you received with the EasyPIC™ v7 for dsPIC30® package:



http://www.mikroe.com/downloads/get/1202/mikroprog_for_plc_drivers_v200.zip

When you locate the drivers, please extract files from the ZIP archive. Folder with extracted files contains folders with drivers for different operating systems. Depending on which operating system you use, choose adequate folder and open it.



In the opened folder you should be able to locate the driver setup file. Double click on setup file to begin installation of the programmer drivers.

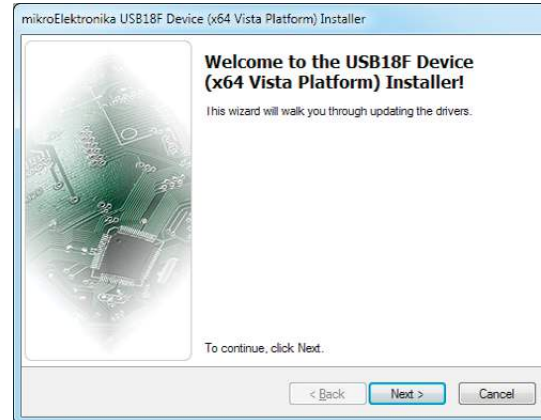

Step 1 - Start Installation

Welcome screen of the installation. Just click on **Next** button to proceed.

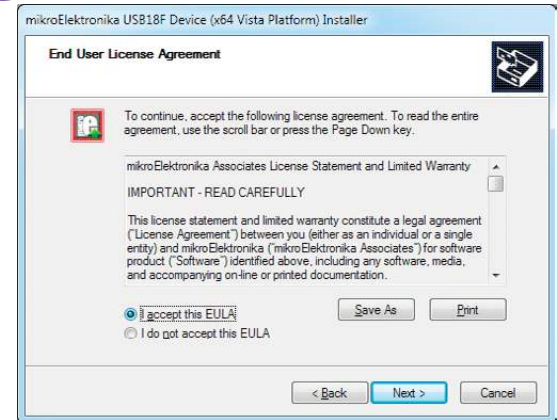

Step 2 - Accept EULA

Carefully read **End User License Agreement**. If you agree with it, click **Next** to proceed.

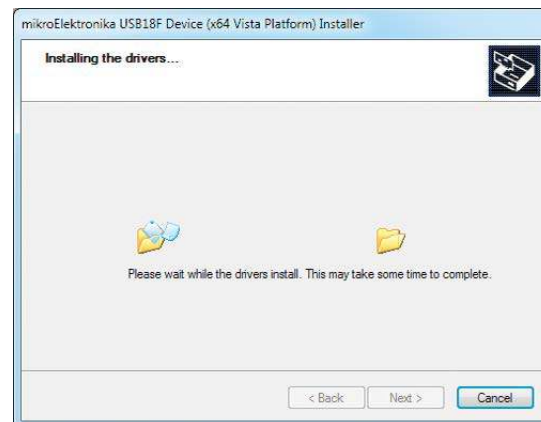

Step 3 - Installing drivers

Drivers are installed automatically in a matter of seconds.

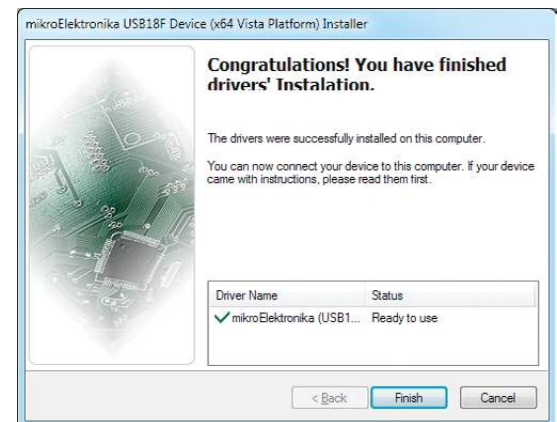

Step 4 - Finish installation

You will be informed if the drivers are installed correctly. Click on **Finish** button to end installation process.

Programming software

mikroProg Suite™ for PIC®

On-board **mikroProg™** programmer requires special programming software called **mikroProg Suite™ for PIC®**. This software is used for programming all of Microchip® microcontroller families, including PIC10, PIC12, PIC16, PIC18, dsPIC30/33, PIC24 and PIC32. Software has intuitive interface and **SingleClick™** programming technology. To begin, first locate the installation archive on our website:



http://www.mikroe.com/downloads/get/1201/mikroprog_suite_for_pic.zip

After downloading, extract the package and double click the executable setup file, to start installation.

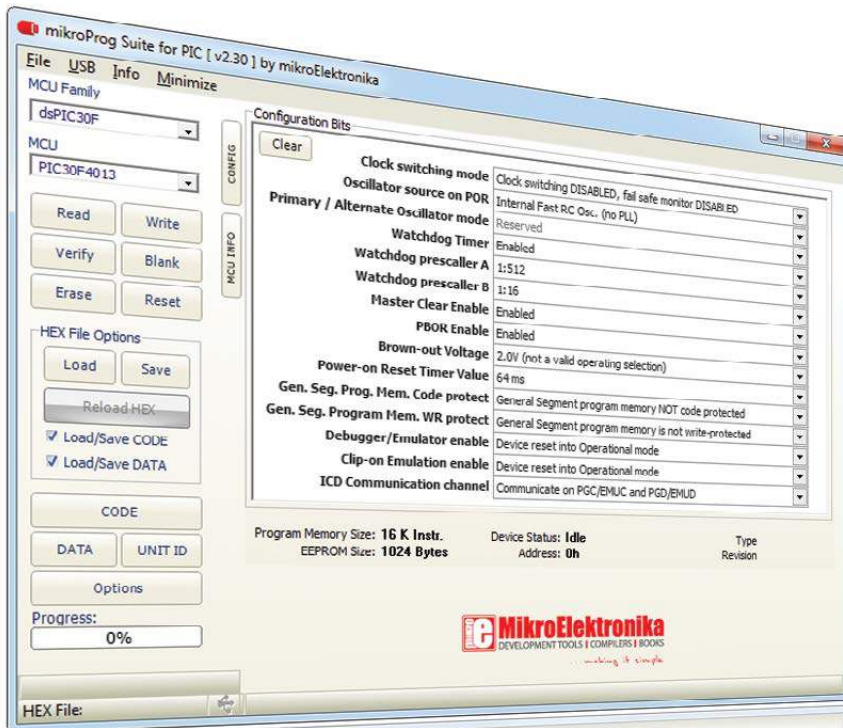

EasyPIC™ v7
for dsPIC30



Installation wizard - 6 simple steps



Step 1 - Start Installation



Step 2 - Accept EULA and continue

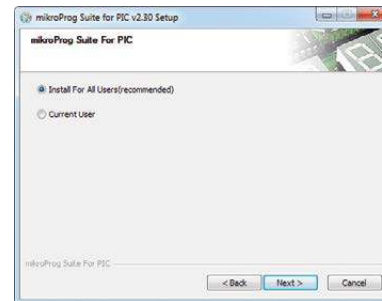

Step 3 - Install for All users or current user

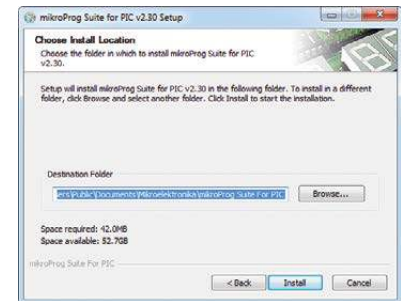

Step 4 - Choose destination folder

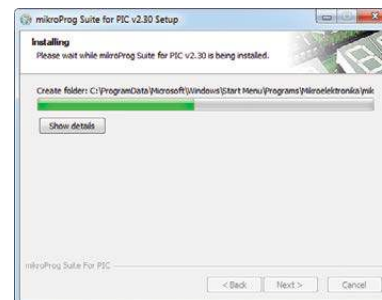

Step 5 - Installation in progress

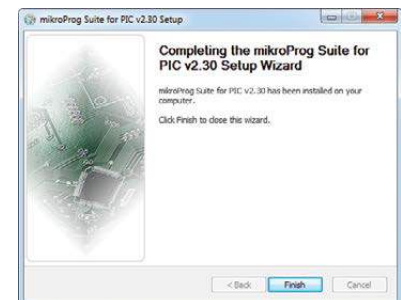

Step 6 - Finish Installation

mikroICD™ - In Circuit Debugger

What is Debugging?

Every developer comes to a point where he has to monitor the code execution in order to find errors in the code, or simply to see if everything is going as planned. This hunt for bugs, or errors in the code is called **debugging**. There are two ways to do this: one is **the software simulation**, which enables you to simulate what is supposed to be happening on the microcontroller as your code lines are executed, and the other, most reliable one, is monitoring the code execution on the chip itself. And this latter one is called **In-Circuit debugging**. "In-Circuit" means that it is the real deal - code executes right on the target device.

What is mikroICD™?

The on-board **mikroProg™** programmer supports **mikroICD™** - a highly effective tool for a **Real-Time debugging** on hardware level. The mikroICD™ debugger enables you to execute your program on the host PIC microcontroller and view variable values, Special Function Registers (SFR), RAM, CODE and EEPROM memory along with the mikroICD™ code execution on hardware. Whether you are a beginner, or a professional, this powerful tool, with intuitive interface and convenient set of commands will enable you to track down bugs quickly. mikroICD™ is one of the fastest, and most reliable debugging tools on the market.

Supported Compilers

All MikroElektronika compilers, **mikroC™**, **mikroBasic™** and **mikroPascal™** for PIC®, dsPIC® and PIC32® natively support mikroICD™. Specialized mikroICD™ DLL module allows compilers to exploit the full potential of fast hardware debugging. Along with compilers, make sure to install the appropriate **programmer drivers** and **mikroProg Suite™ for PIC®** programming software, as described on **pages 12** and **13**.

How do I use the debugger?

When you build your project for debugging, and program the microcontroller with this HEX file, you can start the debugger using **[F9]** command. Compiler will change layout to debugging view, and a blue line will mark where code execution is currently paused. Use **debugging toolbar** in the **Watch Window** to guide the program execution, and stop anytime. Add the desired variables to Watch Window and monitor their values. Complete guide to using mikroICD™ with your compiler is provided with the EasyPIC™ v7 for dsPIC30® package.



Figure 5-2: mikroICD™ manual explains debugging thoroughly

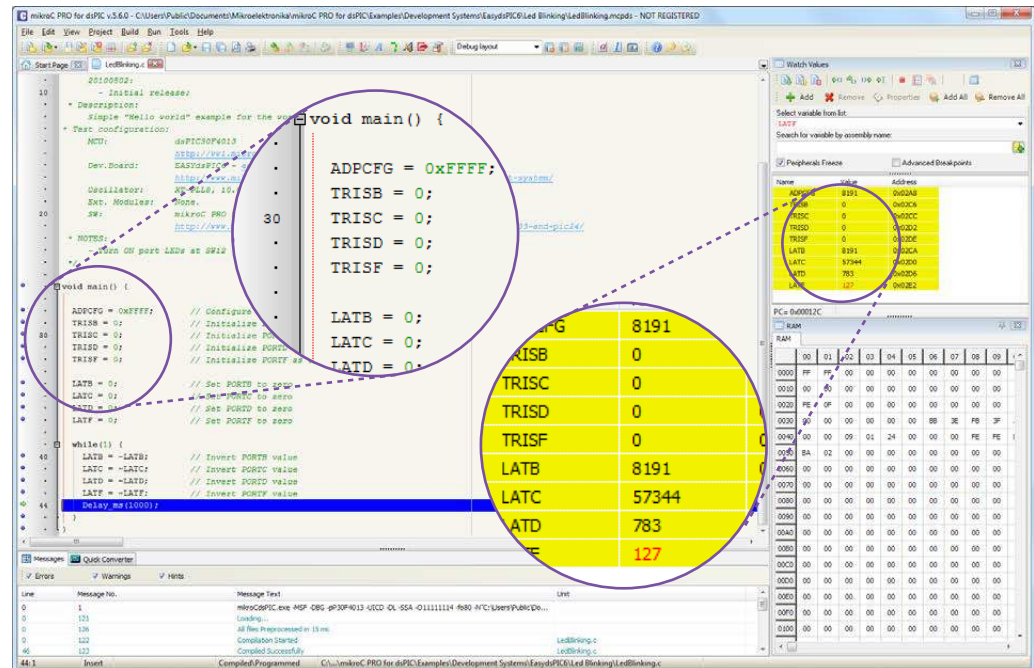

Figure 5-3: mikroC PRO for dsPIC® compiler in debugging view, with SFR registers in Watch Window



mikroCD™ commands



Here is a short overview of which debugging commands are supported in MikroElektronika compilers. You can see what each command does, and what are their shortcuts when you are in debugging mode. It will give you some general picture of what your debugger can do.

Toolbar Icon	Command Name	Shortcut	Description
	Start Debugger	[F9]	Starts Debugger.
	Run/Pause Debugger	[F6]	Run/Pause Debugger.
	Stop Debugger	[Ctrl + F2]	Stops Debugger.
	Step Into	[F7]	Executes the current program line, then halts. If the executed program line calls another routine, the debugger steps into the routine and halts after executing the first instruction within it.
	Step Over	[F8]	Executes the current program line, then halts. If the executed program line calls another routine, the debugger will not step into it. The whole routine will be executed and the debugger halts at the first instruction following the call.
	Step Out	[Ctrl + F8]	Executes all remaining program lines within the subroutine. The debugger halts immediately upon exiting the subroutine.
	Run To Cursor	[F4]	Executes the program until reaching the cursor position.
	Toggle Breakpoint	[F5]	Toggle breakpoints option sets new breakpoints or removes those already set at the current cursor position.
	Show/Hide breakpoints	[Shift+F4]	Shows/Hides window with all breakpoints
	Clears breakpoints	[Shift+Ctrl+F5]	Deletes selected breakpoints
	Jump to interrupt	[F2]	Opens window with available interrupts (doesn't work in mikroCD™ mode)

UART via RS-232



Enabling RS-232

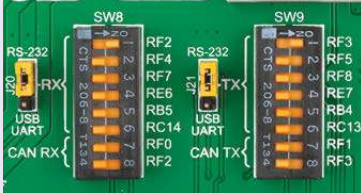

In order to enable RS-232 communication, you must set **J20** and **J21** jumpers in the **RS-232** position, and enable desired **RX** and **TX** lines via **SW8** and **SW9** DIP switches. For example, if you want to enable RS-232 connection on UART1 module of the default **dsPIC30F4013** chip, you should enable **SW8.1** (RF2) and **SW9.1** (RF3) lines.

The **UART** (universal asynchronous receiver/transmitter) is one of the most common ways of exchanging data between the MCU and peripheral components. It is a serial protocol with separate transmit and receive lines, and can be used for full-duplex communication. Both sides must be initialized with the same baud rate, otherwise the data will not be received correctly.

RS-232 serial communication is performed through a 9-pin SUB-D connector and the microcontroller UART module. In order to enable this communication, it is necessary to establish a connection between **RX** and **TX** lines on SUB-D connector and the same pins on the target microcontroller using DIP switches. Since RS-232 communication voltage levels are different than microcontroller logic levels, it is necessary to use a RS-232 Transceiver circuit, such as **MAX3232** as shown on **Figure 6-1**.

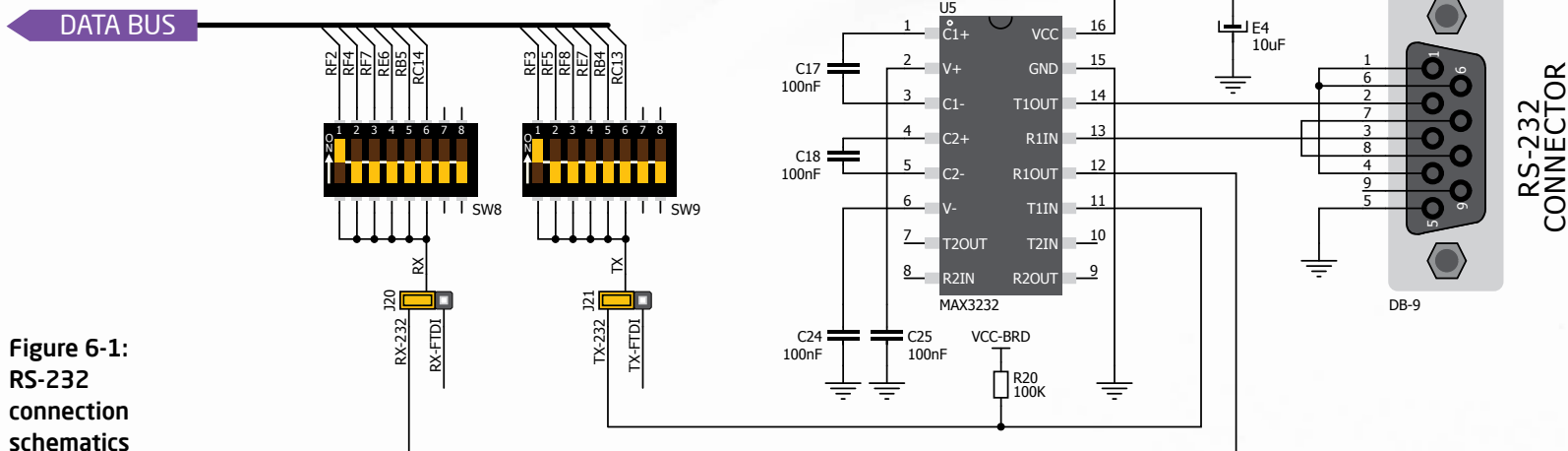
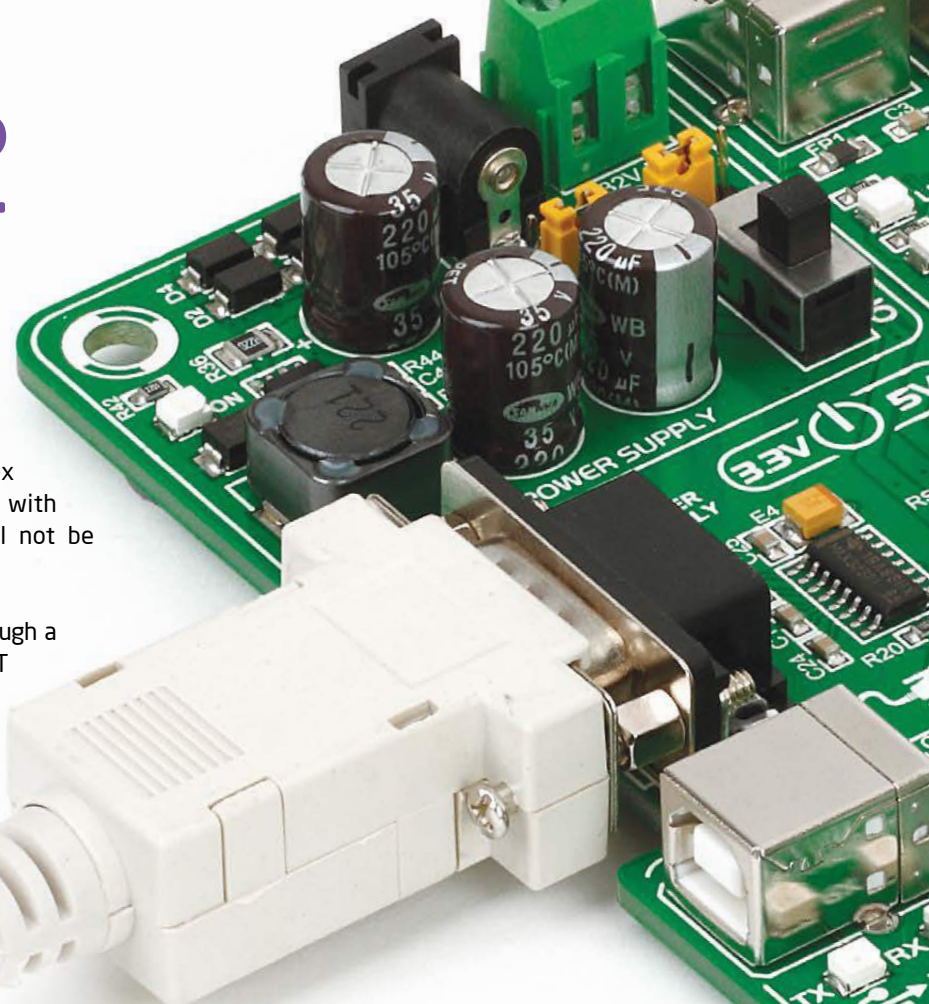

Figure 6-1:
RS-232
connection
schematics

UART via USB



Enabling USB-UART



In order to enable USB-UART communication, you must set **J20** and **J21** jumpers in the **USB-UART** position, and enable desired **RX** and **TX** lines via **SW8** and **SW9** DIP switches. For example, if you want to enable USB-UART connection on UART1 module of the default **dsPIC30F4013** chip, you should enable **SW8.1** (RF2) and **SW9.1** (RF3) lines.

Modern PC computers, laptops and notebooks are no longer equipped with RS-232 connectors and UART controllers. They are nowadays replaced with USB connectors and USB controllers. Still, certain technology enables UART communication to be done over USB connection. Controllers such as **FT232RL** from FTDI® convert UART signals to the appropriate USB standard. In order to use USB-UART module on EasyPIC™ v7 for dsPIC30®, you must first install FTDI drivers on your computer. Drivers can be found on the link below:



<http://www.ftdichip.com/Drivers/VCP.htm>

USB-UART communication is being done through a FT232RL controller, USB connector (**CN2**), and microcontroller UART module. To establish this connection, you must put **J20** and **J21** jumpers in the **USB-UART** position, and connect **RX** and **TX** lines of the microcontroller to the appropriate input and output pins of the FT232RL. This selection is done using DIP switches **SW8** and **SW9**.

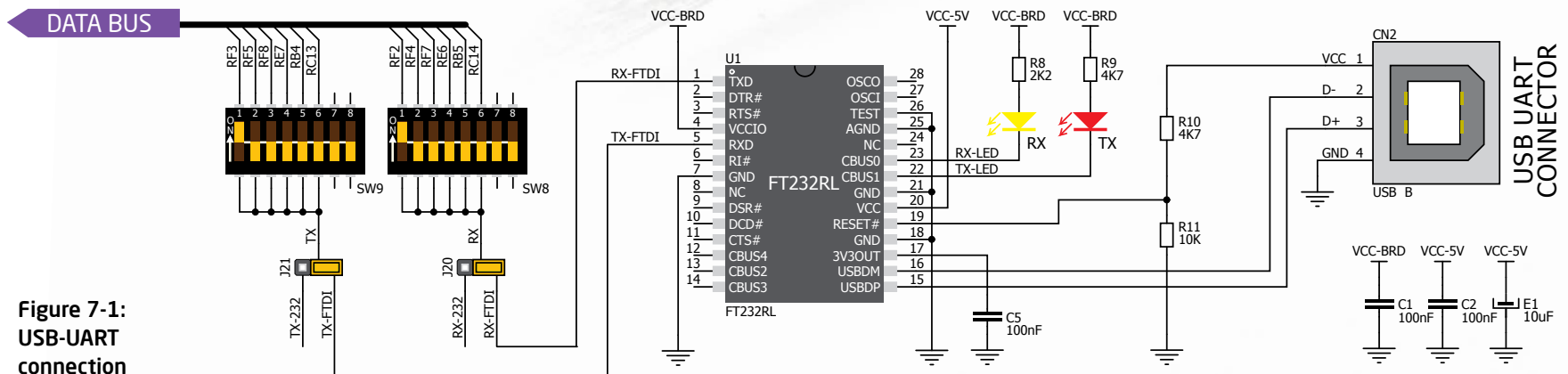
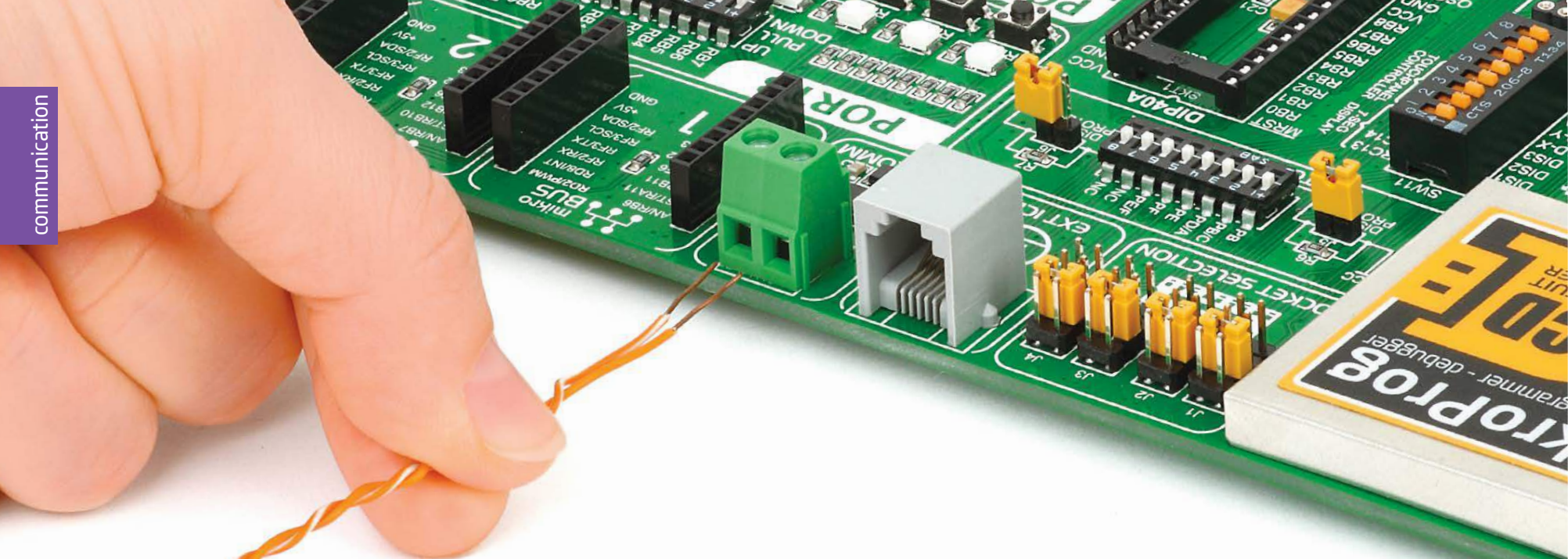

Figure 7-1:
USB-UART
connection
schematics



CAN communication

Controller Area Network (CAN or CAN bus) is a vehicle bus standard designed to allow microcontrollers and devices to communicate with each other within a vehicle without a host computer. CAN is a message-based protocol, designed specifically for automotive applications but now also used in other areas such as industrial automation and medical equipment. EasyPIC™ v7 for dsPIC30® is equipped with high-speed **MCP2551** CAN Transceiver and a pair of screw terminals which provide microcontrollers with integrated CAN controller with the necessary physical interface for CAN communication. Make sure to correctly connect negative and positive differential communication lines before using this module.



Enabling CAN

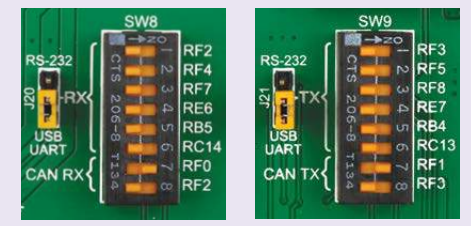

In order to enable CAN communication, you must push **SW8.7** (RF0) or **SW8.8** (RF2) and **SW9.7** (RF1) or **SW9.8** (RF3) to **ON** position. This connects the **TX** and **RX** lines to appropriate microcontroller pins and its CAN module.

DATA BUS

Figure 8-1: CAN connection schematics

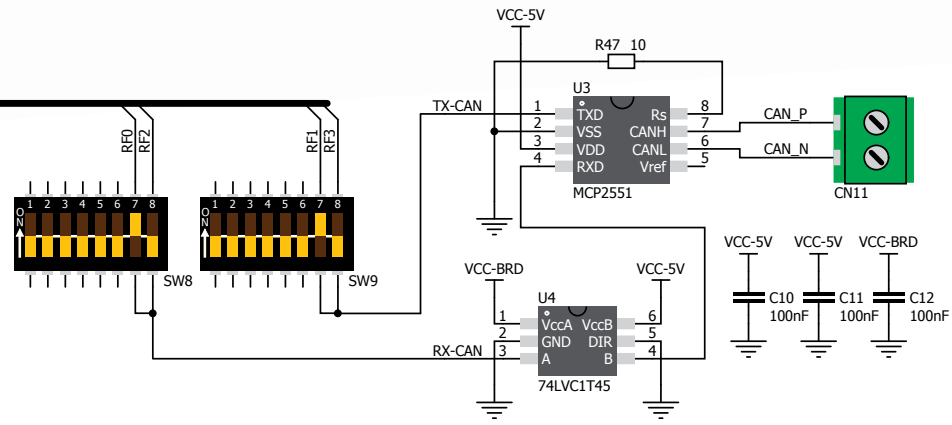

mikroBUS™ sockets

Easier connectivity and simple configuration are imperative in modern electronic devices. Success of the USB standard comes from its simplicity of usage and high and reliable data transfer rates. As we in MikroElektronika see it, Plug-and-Play devices with minimum settings are the future in embedded world too. This is why our engineers have come up with a simple, but brilliant pinout with lines that most of today's accessory boards require, which almost completely eliminates the need of additional hardware settings. We called this new standard the **mikroBUS™**. EasyPIC™ v7 for dsPIC30® supports mikroBUS™ with two on-board sockets. As you can see, there are no additional DIP switches, or jumper selections. Everything

is already routed to the most appropriate pins of the microcontroller sockets.

mikroBUS™ host connector

Each mikroBUS™ host connector consists of two 1x8 female headers containing pins that are most likely to be used in the target accessory board. There are three groups of communication pins: **SPI, UART** and **I²C** communication. There are also single pins for **PWM, Interrupt, Analog input, Reset** and **Chip Select**. Pinout contains two power groups: **+5V and GND** on one header and **+3.3V and GND** on the other 1x8 header.

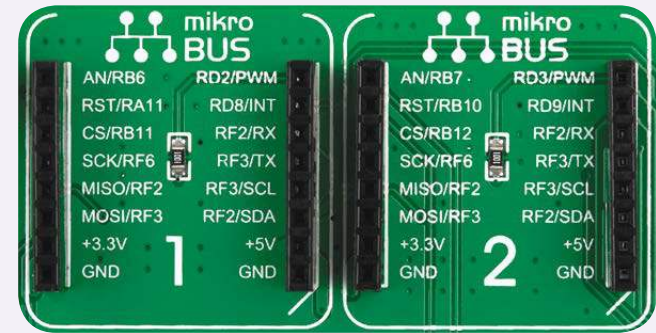

mikroBUS™ pinout explained

- | | |
|-------------------------------------|--------------------------------------|
| AN - Analog pin | PWM - PWM output line |
| RST - Reset pin | INT - Hardware Interrupt line |
| CS - SPI Chip Select line | RX - UART Receive line |
| SCK - SPI Clock line | TX - UART Transmit line |
| MISO - SPI Slave Output line | SCL - I2C Clock line |
| MOSI - SPI Slave Input line | SDA - I2C Data line |
| +3.3V - VCC-3.3V power line | +5V - VCC-5V power line |
| GND - Reference Ground | GND - Reference Ground |

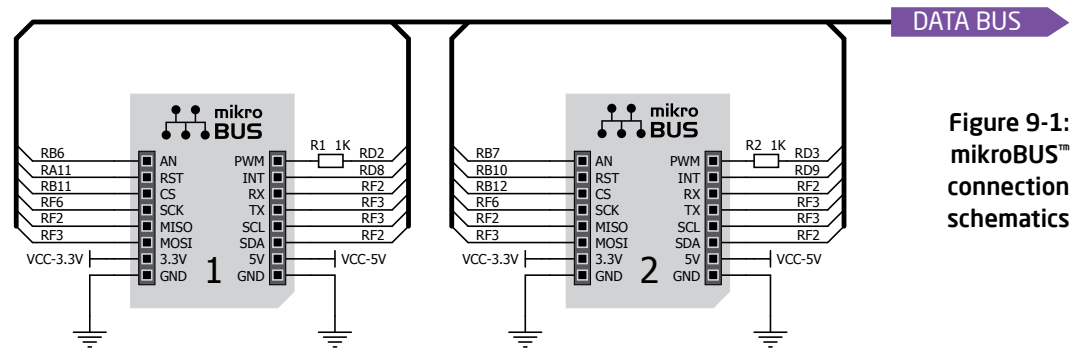
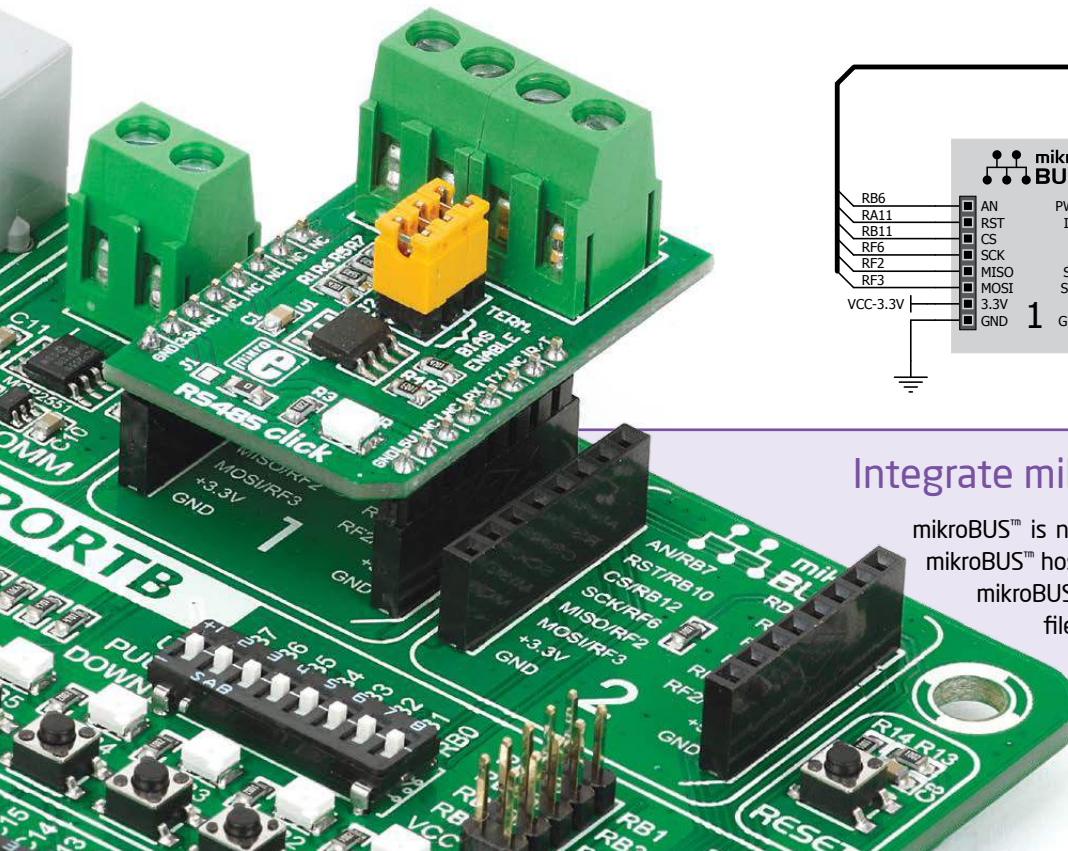

Figure 9-1:
mikroBUS™
connection
schematics

Integrate mikroBUS™ in your design

mikroBUS™ is not made to be only a part of our development boards. You can freely place mikroBUS™ host connectors in your final PCB designs, as long as you clearly mark them with mikroBUS™ logo and footprint specifications. For more information, logo artwork and PCB files visit our web site:



<http://www.mikroe.com/mikrobus/>

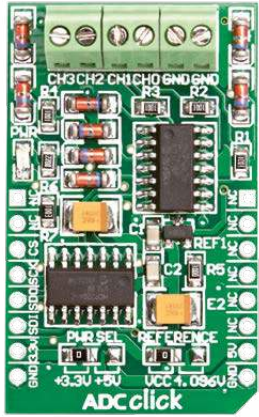

ADC click™

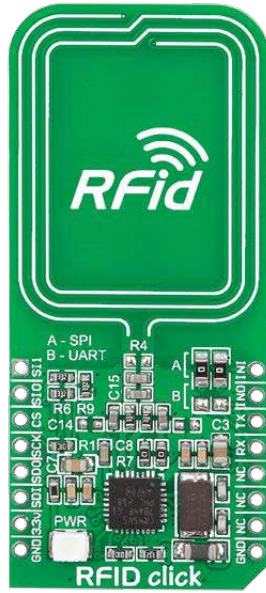

RFID click™



Bluetooth click™

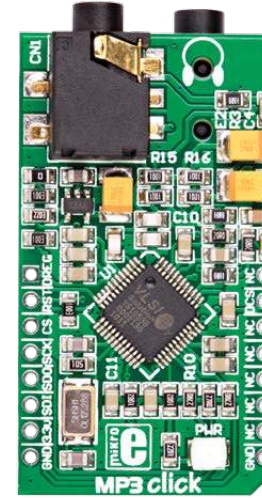

MP3 click™



GSM click™

Click Boards™ are plug-n-play!

MikroElektronika portfolio of over 200 accessory boards is now enriched by an additional set of mikroBUS™ compatible **Click Boards™**. Almost each month several new Click boards™ are released. It is our intention to provide the community with as much of these boards as possible, so you will be able to expand your EasyPIC™ v7 for dsPIC30® with additional functionality with

literally zero hardware configuration. Just plug and play. Visit the Click boards™ webpage for the complete list of available boards:



<http://www.mikroe.com/click/>

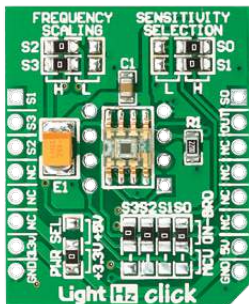

LightHz click™

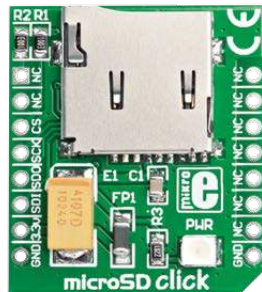

microSD click™

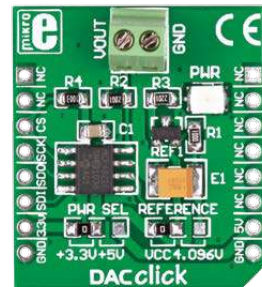

DAC click™



DIGIPOT click™

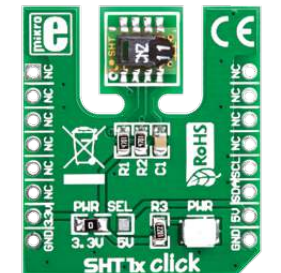

SHT1x click™



WiFi PLUS click™



GPS click™

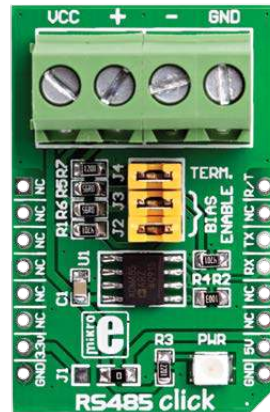

RS485 click™

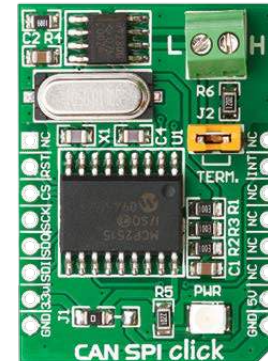

CAN SPI click™

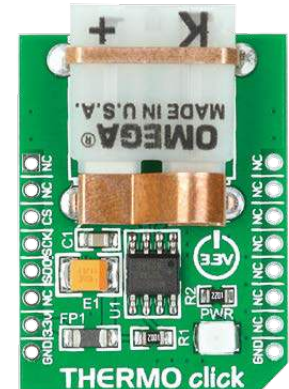

THERMO click™

LIBSTOCK™ A PLACE FOR CODE®

BROWSE CODE
SHARE CODE
REQUEST CODE
ABOUT LIBSTOCK



Code Examples

It easy to get your Click™ board up and running. We provided the examples for mikroC™, mikroBasic™ and mikroPascal™ compilers on our [Libstock community web site](http://www.libstock.com). Just download them and you are ready to start:

<http://www.libstock.com>

Use your forum account to login.

LOGIN

Username:

Password:

▶ LOGIN

Not registered? [Sign Up for free!](#)

CODE CATEGORIES

All codes (789)

- ▶ Audio & Speech (20)
- ▶ Communication (194)
- ▶ Graphics & LCD (94)

CATEGORIES

All codes
 Libraries
 Projects
 Visual Projects
 Examples

COMPILERS

mikroC
 mikroBasic
 mikroPascal
 Other Compilers

SORT BY

best rank
 oldest
 by author
 alphabetically
 most downloaded
 with source
 with example

CATEGORY: ALL CODES

<< previous | 1 | 2 | 3 | 4 | 5 | 6 | 7 | 8 | 9 next >> last

E GSM click - Example

Rating: ★★★★★

Author: MikroElektronika Team

Version: 1.0.0.0

Last Updated: 2014-05-09

Category: GSM / GPRS

Downloaded: 7921 times

Followed by: 2 users

[learn more]

Download [648.97KB]

supported microcontrollers

PIC DSPIC PIC24 PIC32 AVR ARM OTHER

supported compilers

MIKROC MIKROBASIC MIKROPASCAL OTHER

supported visual tools

VISUALITY VISUAL CLCD OTHER

archive format

MIKROC ZIP OBJ

project contains

LIB SRC EXA HEX HEX SCH PCB DOC

Input/Output Group

One of the most distinctive features of EasyPIC™ v7 for dsPIC30® are its Input/Output PORT groups. They add so much to the connectivity potential of the board.

Everything is grouped together

PORT headers, PORT buttons and PORT LEDs are next to each other, and grouped together. It makes development easier, and the entire EasyPIC™ v7 for dsPIC30® cleaner and well organized. We have also provided an **additional PORT headers** on the left side of the board, so you can access any pin you want from both sides of the board.

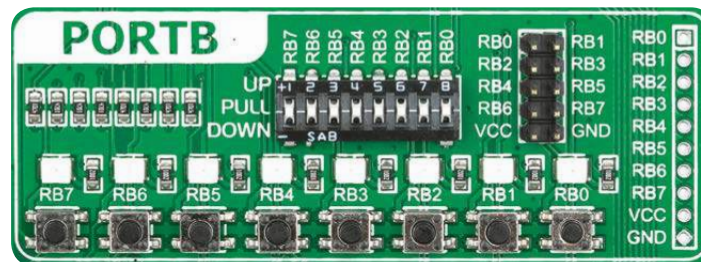

Figure 10-1: I/O group contains PORT headers, tri-state pull up/down DIP switch, buttons and LEDs all in one place

Tri-state pull-up/down DIP switches

Tri-state DIP switches, like **SW1** on **Figure 10-2**, are used to enable 4K7 pull-up or pull-down resistor on any desired port pin. Each of those switches has three states:

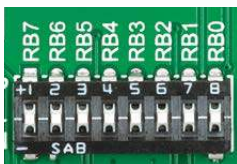

Figure 10-2: Tri-state DIP switch on PORTB

1. **middle position** disables both pull-up and pull-down feature from the PORT pin
2. **up position** connects the resistor in pull-up state to the selected pin
3. **down position** connects the resistor in pull-down state to the selected PORT pin.

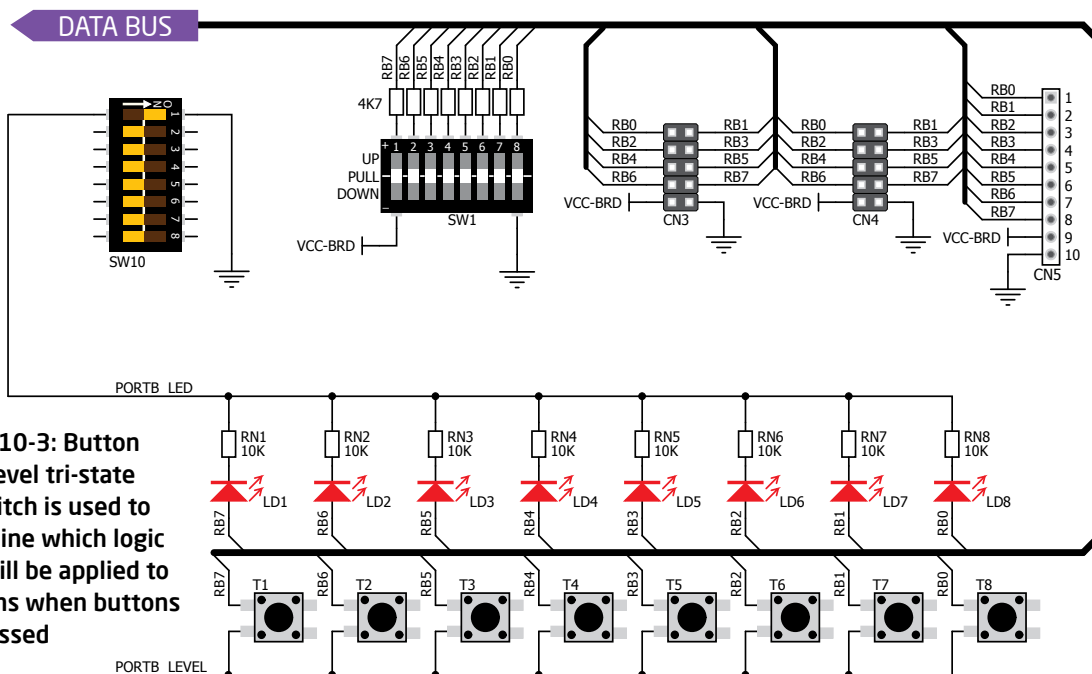

Figure 10-3: Button press level tri-state DIP switch is used to determine which logic level will be applied to port pins when buttons are pressed

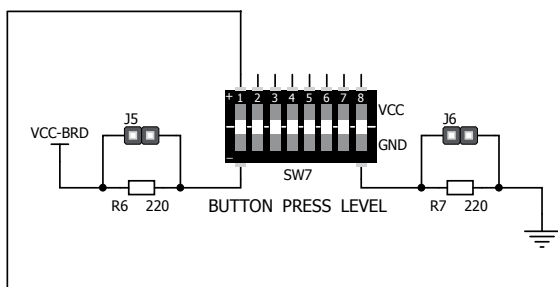
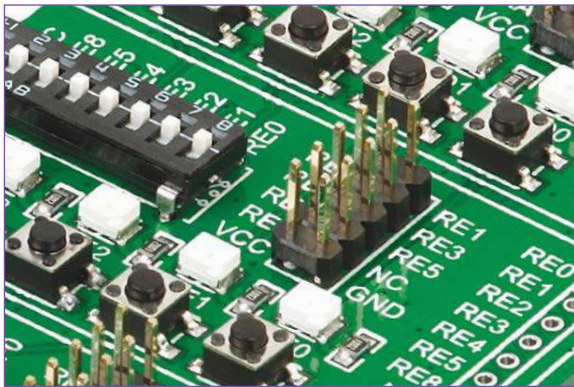

Figure 10-4: Schematic of the single I/O group connected to microcontroller PORTB



Headers

With enhanced connectivity as one of the key features of EasyPIC™ v7 for dsPIC30®, we have provided **two connection headers for each PORT**. I/O PORT group contains one male IDC10 2x5 header (like **CN3** on **Figure 10-4**) and one 1x10 row of connection pads (like **CN5** on **Figure 10-4**). There is **one more IDC10 header** available on the left side of the board, next to the section with displays. These headers are all compatible with all MikroElektronika accessory boards, and enable simple connection.

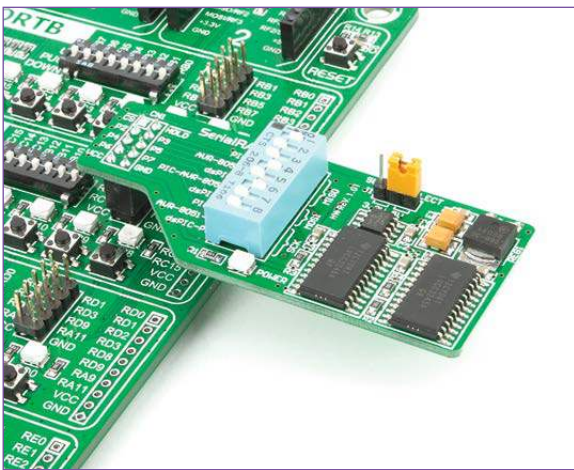
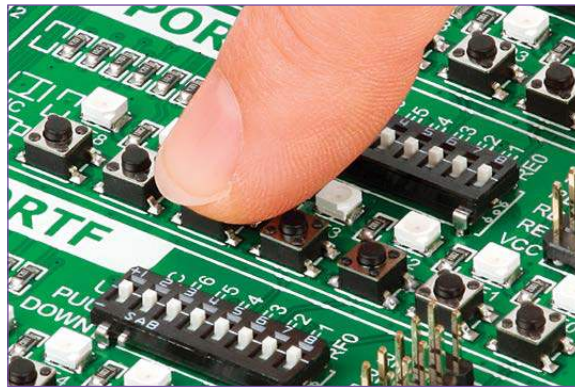

Figure 10-5: IDC10 male headers enable easy connection with MikroElektronika accessory boards



Buttons



Figure 10-6: Button press level DIP switch (tri-state)

The logic state of all microcontroller digital inputs may be changed using **push buttons**. Tri-state DIP switch **SW7** is available for selecting which logic state will be applied to corresponding MCU pin when button is pressed, for each I/O port separately. If you, for example, place **SW7.1** in **VCC** position, then pressing any of push buttons in PORTB I/O group will apply logic one to the appropriate microcontroller pin. The same goes for **GND**. If DIP switch is in the middle position neither of two logic states will be applied to the appropriate microcontroller pin. You can disable pin protection 220ohm resistors by placing jumpers **J5** and **J6**, which will connect your push buttons directly to VCC or GND. Be aware that doing so you may accidentally damage MCU in case of wrong usage.

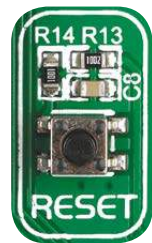

Reset Button

In the far upper right section of the board, there is a **RESET button**, which can be used to manually reset the microcontroller.

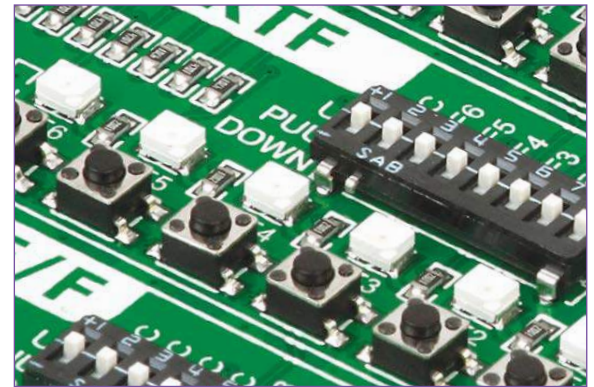

LEDs

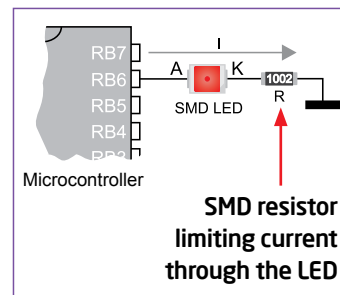

LED (Light-Emitting Diode) is a highly efficient electronic light source. When connecting LEDs, it is necessary to place a current limiting resistor in series so that LEDs are provided with

the current value specified by the manufacturer. The current varies from 0.2mA to 20mA, depending on the type of the LED and the manufacturer. The EasyPIC™ v7 for dsPIC30® board uses low-current LEDs with typical current consumption of 0.2mA or 0.3mA. Board contains 42 LEDs which can be used for visual indication of the logic state on PORT pins. An active LED indicates that a logic high (1) is present on the pin. In order to enable PORT LEDs, it is necessary to enable the corresponding DIP switch on **SW10** (**Figure 10-7**).

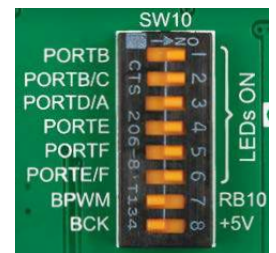
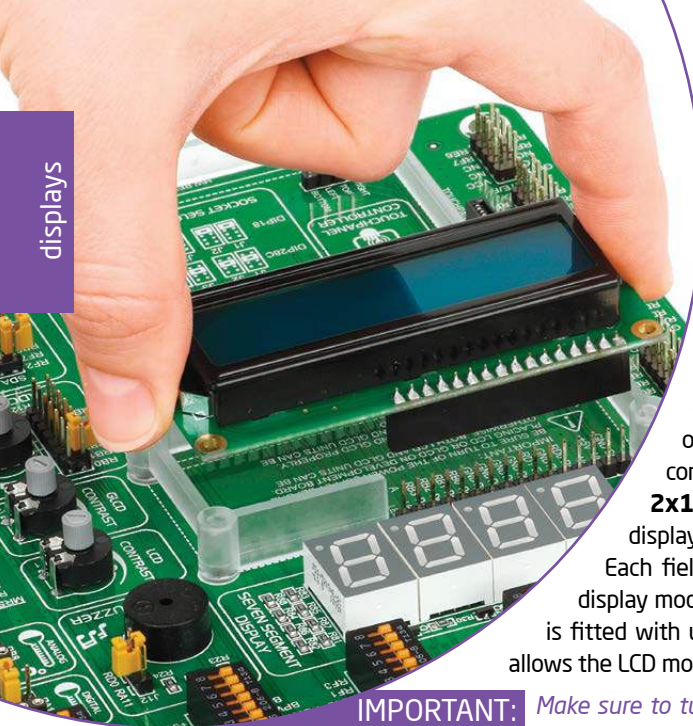

Figure 10-7: SW10.1 through SW10.6 switches are used to enable PORT LEDs



LCD 2x16 characters

Liquid Crystal Displays or LCDs are a cheap and popular way of representing information to the end user of some electronic device. Character LCDs can be used to represent standard and custom characters in the predefined number of fields. EasyPIC™ v7 for dsPIC30® provides the connector and the necessary interface for supporting **2x16 character LCDs** in 4-bit mode. This type of display has two rows consisted of 16 character fields. Each field is a 7x5 pixel matrix. Communication with the display module is done through **CN7** display connector. Board is fitted with uniquely designed plastic display distancer, which allows the LCD module to perfectly and firmly fit into place.

IMPORTANT: *Make sure to turn off the power supply before placing LCD onto the board. Otherwise your display can be permanently damaged.*

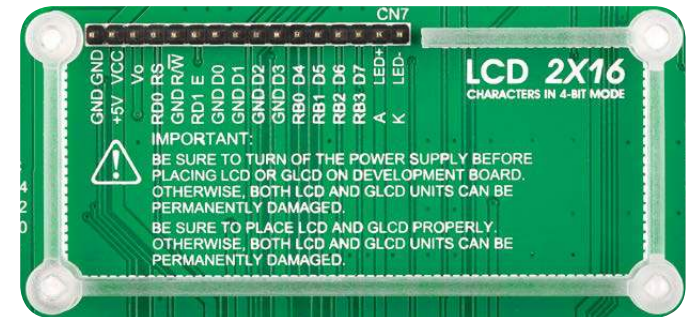

Figure 11-1: On-board LCD 2x16 display connector

Connector pinout explained

GND and **VCC** - Display power supply lines

V0 - LCD contrast level from potentiometer P4

RS - Register Select Signal line

E - Display Enable line

R/W - Determines whether display is in Read or Write mode. It's always connected to GND, leaving the display in Write mode all the time.

D0-D3 - Display is supported in 4-bit data mode, so lower half of the data byte interface is connected to GND.

D4-D7 - Upper half of the data byte

LED+ - Connection with the back light LED anode

LED- - Connection with the back light LED cathode

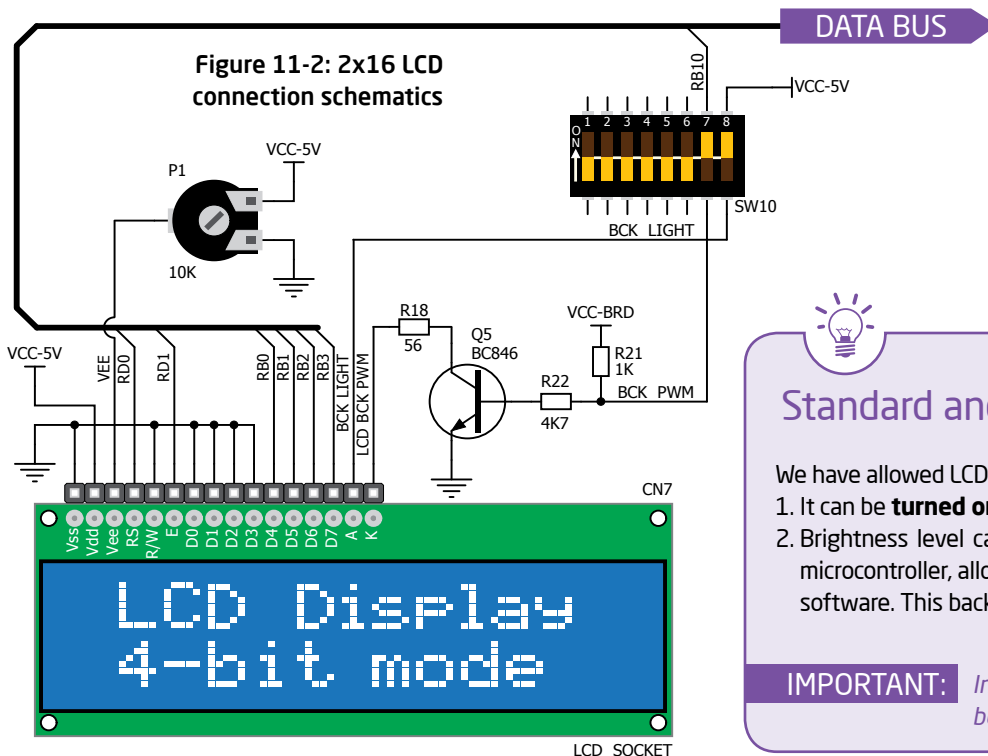

Standard and PWM-driven back light

We have allowed LCD back light to be enabled in two different ways:

1. It can be **turned on with full brightness** using **SW10.8** switch.
2. Brightness level can be determined **with PWM signal** from the microcontroller, allowing you to write custom back light controlling software. This back light mode is enabled with **SW10.7** switch.

IMPORTANT: *In order to use PWM back light both **SW10.7** and **SW10.8** switches must be enabled at the same time.*



GLCD 128x64

Graphical Liquid Crystal Displays, or GLCDs are used to display monochromatic graphical content, such as text, images, human-machine interfaces and other content. EasyPIC™ v7 for dsPIC30® provides the connector and necessary interface for supporting GLCD with resolution of 128x64 pixels, driven by the KS108 or compatible display controller. Communication with the display module is done through **CN16** display connector. Board is fitted with uniquely designed plastic display distancer, which allows the GLCD module to perfectly and firmly fit into place.

Display connector is routed to RF0, RF1, RF4, RF5 (control lines) and to RB0-RB3, RD0-RD3 (data lines) of the microcontroller sockets. Since the same ports are used by 2x16 character LCD display, you cannot use both displays simultaneously. You can control the display contrast using dedicated potentiometer **P2**. Full brightness display back light can be enabled with **SW10.8** switch, and PWM-driven back light with **SW10.7** switch.

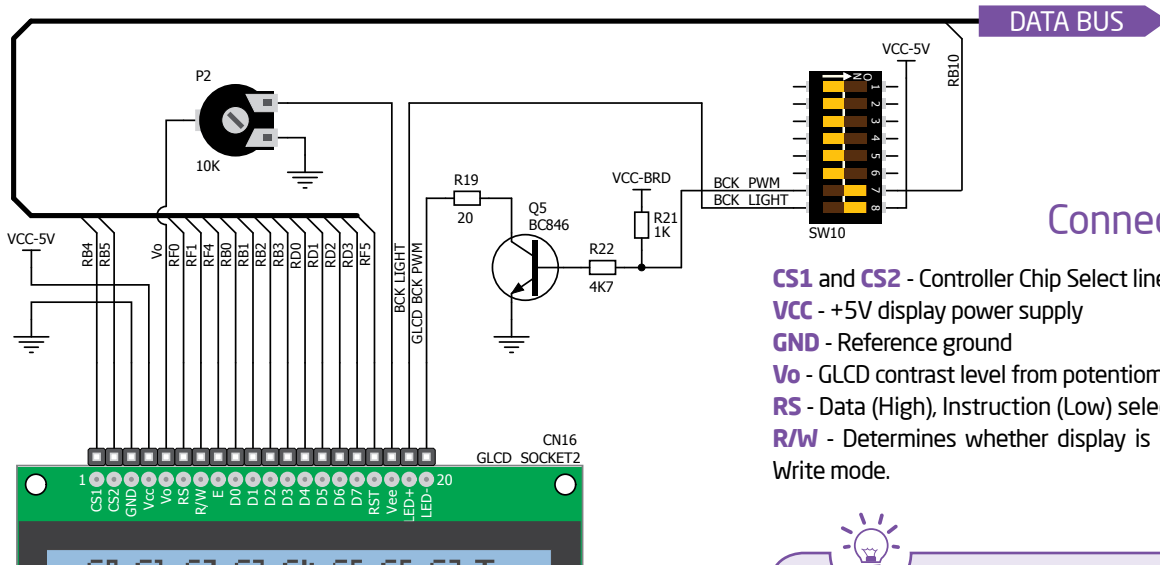
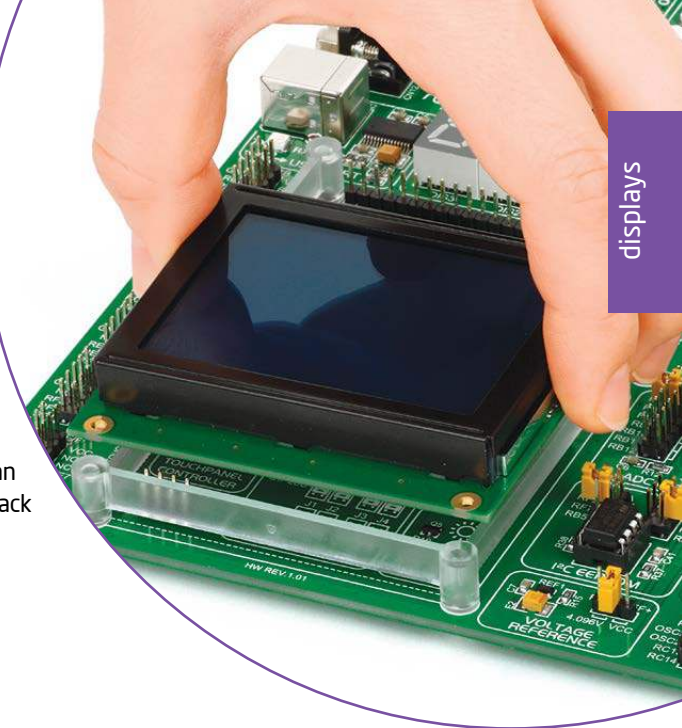

DATA BUS

Connector pinout explained

- CS1** and **CS2** - Controller Chip Select lines
- VCC** - +5V display power supply
- GND** - Reference ground
- V_o** - GLCD contrast level from potentiometer P3
- RS** - Data (High), Instruction (Low) selection line
- R/W** - Determines whether display is in Read or Write mode.

- E** - Display Enable line
- D0-D7** - Data lines
- RST** - Display reset line
- V_{ee}** - Reference voltage for GLCD contrast potentiometer P3
- LED+** - Connection with the back light LED anode
- LED-** - Connection with the back light LED cathode

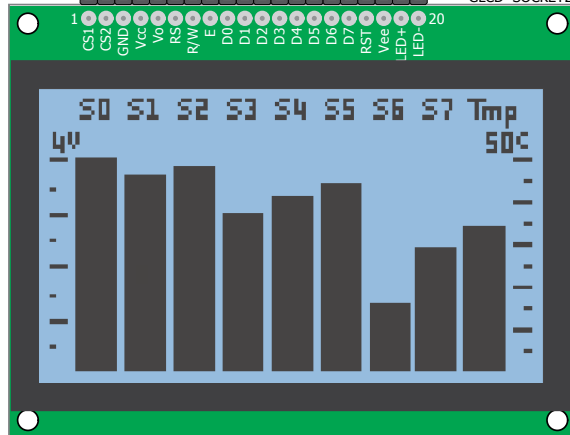

Figure 12-1: GLCD 128x64 connection schematics



Standard and PWM-driven back light

As for LCD, we have allowed GLCD back light to be enabled in two different ways:

1. It can be **turned on with full brightness** using **SW10.8** switch.
2. Brightness level can be determined **with PWM signal** from the microcontroller, allowing you to write custom back light controlling software. This back light mode is enabled with **SW10.7** switch.



IMPORTANT: In order to use PWM back light both **SW10.7** and **SW10.8** switches must be enabled at the same time.

Touch panel controller

Touch panel is a glass panel whose surface is covered with two layers of resistive material. When the screen is pressed, the outer layer is pushed onto the inner layer and appropriate controllers can measure that pressure and pinpoint its location. This is how touch panels can be used as an input devices. EasyPIC™ v7 for dsPIC30®

is equipped with touch panel controller and connector for **4-wire resistive touch panels**. It can very accurately register pressure at a specific point, representing the touch coordinates in the form of analog voltages, which can then be easily converted to X and Y values. Touch panel comes as a part of display.

Correctly placing the touch panel cable into the connector

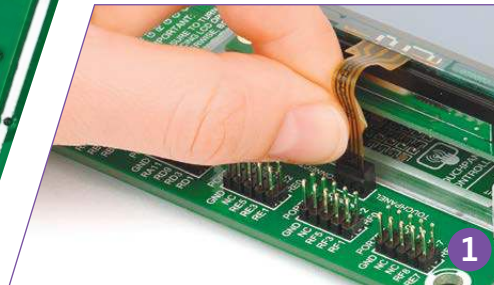

Figure 13-1: Put Touch Panel flat cable in the connector

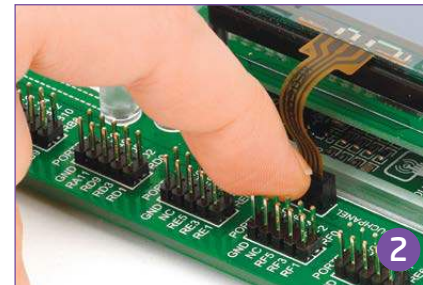

Figure 13-2: Use a tip of your finger to push it inside

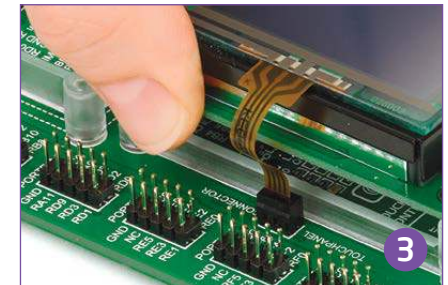

Figure 13-3: Now place GLCD with Touch panel into GLCD socket

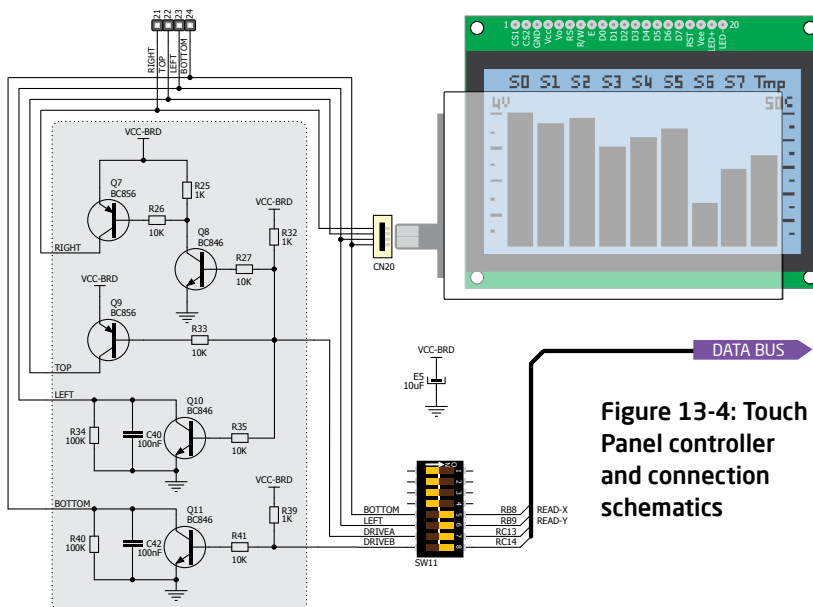

Figure 13-4: Touch Panel controller and connection schematics



Enabling Touch panel

Touch panel is enabled using **SW11.5**, **SW11.6**, **SW11.7** and **SW11.8** switches. They connect **BOTTOM (READ-X)** and **LEFT (READ-Y)** lines of the touch panel with **RB8** and **RB9** analog inputs, and **DRIVEA** and **DRIVEB** with **RC13** and **RC14** digital outputs on microcontroller sockets. Make sure to disconnect other peripherals, LEDs and additional pull-up or pull-down resistors from the interface lines in order not to interfere with signal/data integrity.

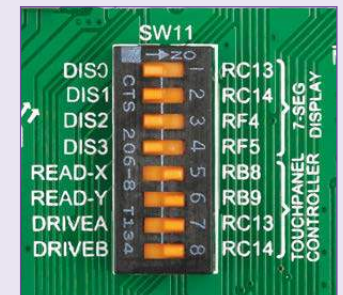
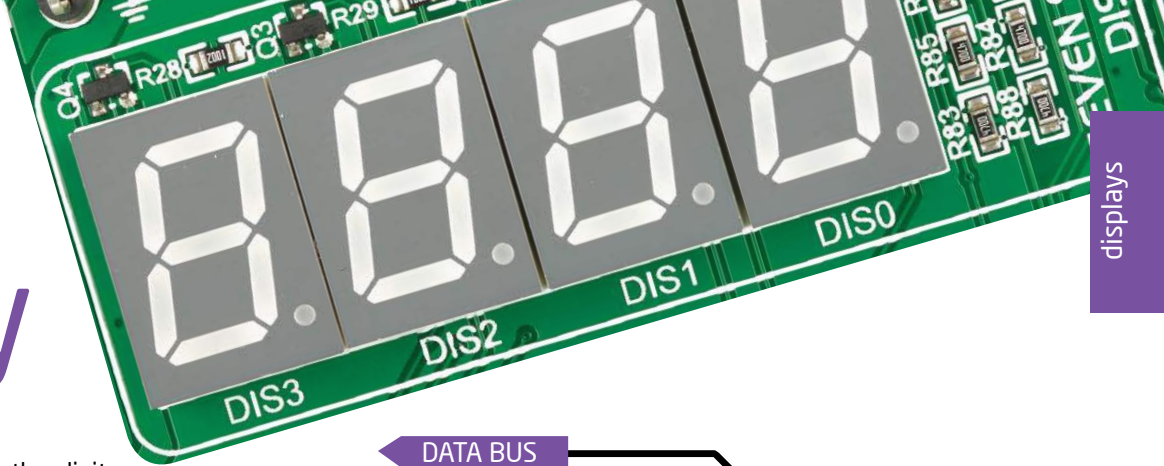

Figure 13-5: Turn on switches 5 through 8 on SW11 to enable Touch panel controller

4 digit 7-seg display



One seven segment digit consist of 7+1 LEDs which are arranged in a specific formation which can be used to represent digits from 0 to 9 and even some letters. One additional LED is used for marking the decimal dot, in case you want to write a decimal point in the desired segment. EasyPIC™ v7 for dsPIC30® contains four of these digits put together to form 4-digit 7-segment display. Driving such a display is done using **multiplexing techniques**. Data lines are shared between segments, and therefore the same segment LEDs in each digit are connected in parallel. Each digit has it's **unique digit select line**,

which is used to enable the digit to which the data is currently being sent. By multiplexing data through all four segments fast enough, you create an illusion that all four segments are in operation simultaneously. This is possible because human eye has a slower reaction time than the mention changes. This way you can represent numbers in decimal or hexadecimal form. Eight data lines that are common for all the digits are connected to PORTB, and digit select lines are connected to RC13, RC14, RF4 and RF5 lines on the microcontroller sockets.



Enabling the display

To enable digit select lines for the 4-digit 7-segment display you have to turn on **SW11.1, SW11.2, SW11.3** and **SW11.4** switches. Digit select lines are connected to **RC13, RC14, RF4** and **RF5** pins on the microcontroller sockets, while data lines are connected to **RB0 - RB7** pins. Make sure to disconnect other peripherals from the interface lines in order not to interfere with signal/data integrity.

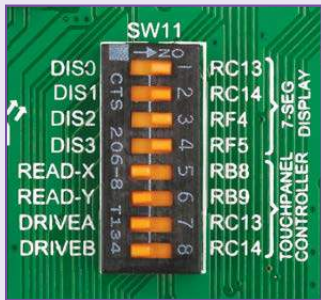

Figure 14-1: Turn on switches 1 through 4 on SW11 to enable 4-digit 7-seg display

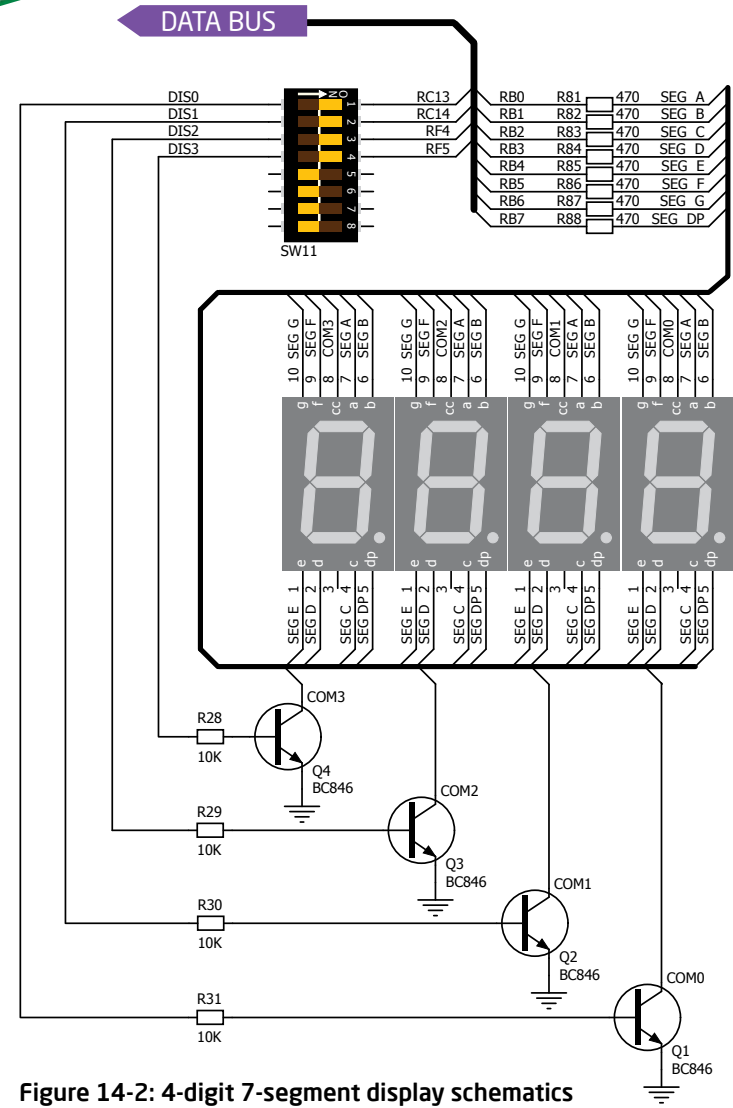

Figure 14-2: 4-digit 7-segment display schematics

DS1820 - Digital Temperature Sensor

DS1820 is a digital temperature sensor that uses **1-wire® interface** for its operation. It is capable of measuring temperatures within the range of -55 to 128°C, and provides $\pm 0.5^\circ\text{C}$ accuracy for temperatures within the range of -10 to 85°C. It requires 3V to 5.5V power supply for stable operation. It takes maximum

of 750ms for the DS1820 to calculate temperature with 9-bit resolution. **1-wire® serial communication** enables data to be transferred over a single communication line, while the process itself is under the control of the master microcontroller. The advantage of such communication is that only one microcontroller pin is used. Multiple

sensors can be connected on the same line. All slave devices by default have a unique ID code, which enables the master device to easily identify all devices sharing the same interface. Board provides a separate socket (**TS1**) for the DS1820. Communication line with the microcontroller is connected via jumper **J9**.

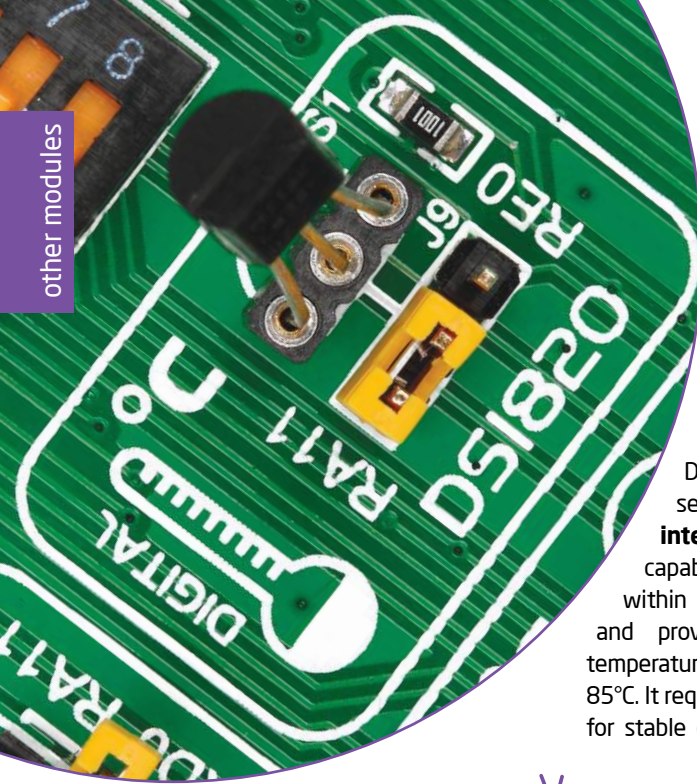

Enabling DS1820 Sensor

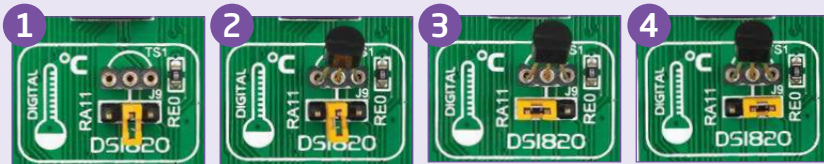

Figure 15-1: DS1820 not connected

Figure 15-2: DS1820 placed in socket

Figure 15-3: DS1820 connected to RA11 pin

Figure 15-4: DS1820 connected to RE0 pin

EasyPIC™ v7 for dsPIC30® enables you to establish 1-wire® communication between **DS1820** and the microcontroller via **RA11** or **RE0** microcontroller pins. The selection of either of those two lines is done using **J9** jumper. When placing the sensor in the socket make sure that half-circle on the board's silkscreen markings matches the rounded part of the DS1820 sensor. If you accidentally connect the sensor the other way, it may be permanently damaged. Make sure to disconnect other peripherals (except 1-wire), LEDs and additional pull-up or pull-down resistors from the interface lines in order not to interfere with signal/data integrity.

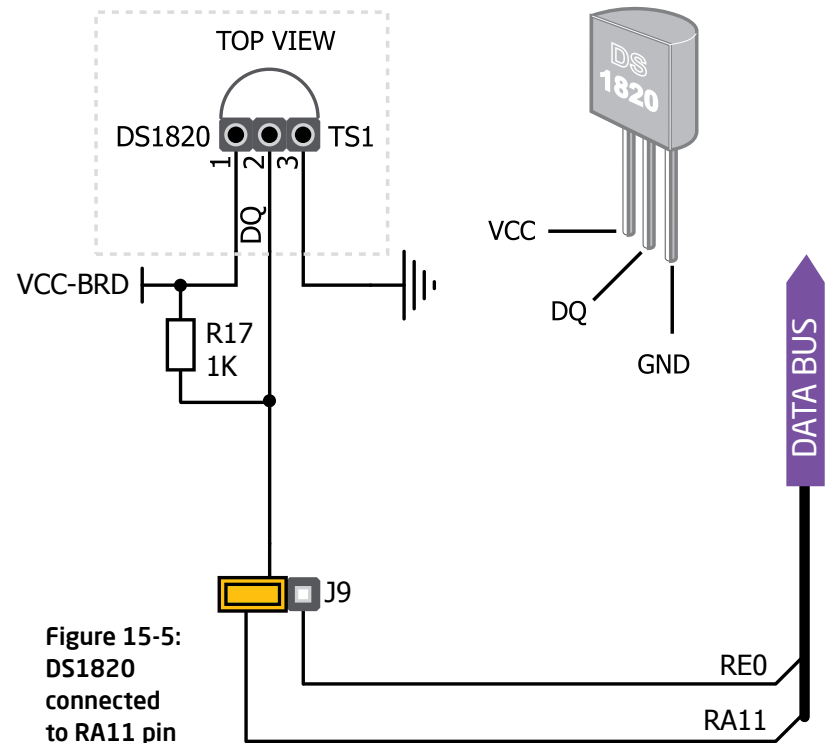

Figure 15-5: DS1820 connected to RA11 pin

LM35 - Analog Temperature Sensor

The **LM35** is a low-cost precision integrated-circuit temperature sensor, whose output voltage is linearly proportional to the Celsius (Centigrade) temperature. The LM35 thus has an advantage over linear temperature sensors calibrated in ° Kelvin, as the user is not required to subtract a large constant voltage from its output to

obtain convenient Centigrade scaling. It has a linear $+10.0 \text{ mV}/^\circ\text{C}$ scale factor and less than $60 \mu\text{A}$ current drain. As it draws only $60 \mu\text{A}$ from its supply, it has very low self-heating, less than 0.1°C in still air. EasyPIC™ v7 for dsPIC30® enables you to get analog readings from the LM35 sensor in restricted temperature range from $+2^\circ\text{C}$ to $+150^\circ\text{C}$.

Board provides a separate socket (**TS2**) for the LM35 sensor in TO-92 plastic packaging. Readings are done with microcontroller using single analog input line, which is selected with jumper **J13**. Jumper connects the sensor with either **PB8** or **PB10** microcontroller pins.

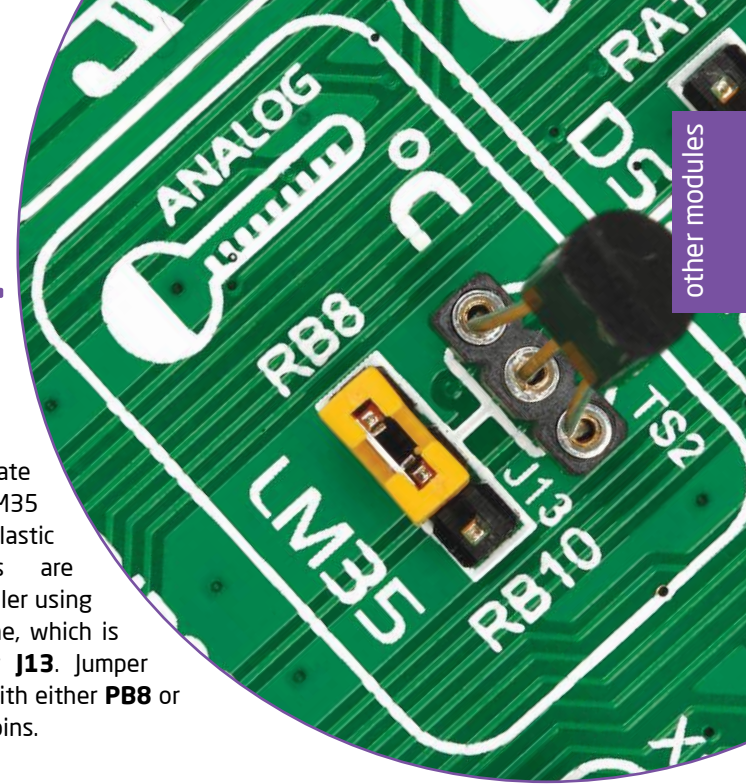

Enabling LM35 Sensor

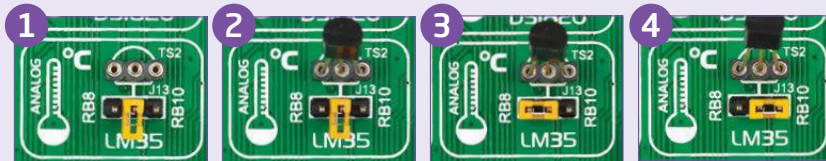

Figure 16-1:
LM35 not connected

Figure 16-2:
LM35 placed in socket

Figure 16-3:
LM35 connected to RB8 pin

Figure 16-4:
LM35 connected to RB10 pin

EasyPIC™ v7 for dsPIC30® enables you to get analog readings from the LM35 sensor using **RB8** or **RB10** microcontroller pins. The selection of either of those two lines is done using **J13** jumper. When placing the sensor in the socket make sure that half-circle on the board's silkscreen markings matches the rounded part of the LM35 sensor. If you accidentally connect the sensor the other way, it can be permanently damaged and you might need to replace it with another one. During the sensor readings make sure that no other device is using the selected analog line, as that may interfere with the readings.

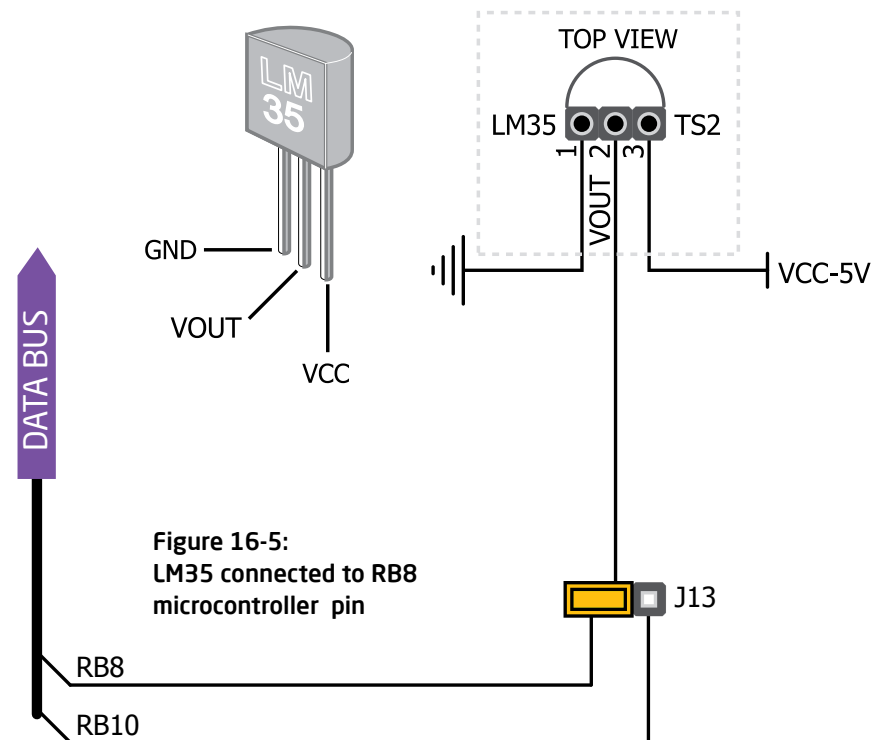
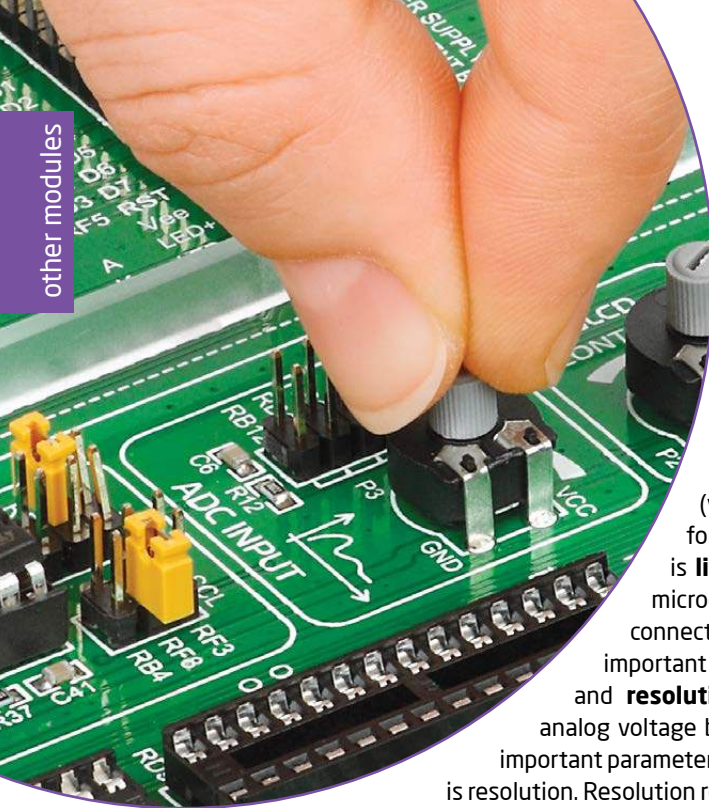

Figure 16-5:
LM35 connected to RB8 microcontroller pin

ADC inputs



Digital signals have **two discrete states**, which are decoded as **high** and **low**, and interpreted as **logic 1** and **logic 0**. **Analog signals**, on the other hand, are **continuous**, and can have any value within defined range. **A/D converters** are specialized circuits which can convert analog signals (voltages) into a digital representation, usually in form of an **integer number**. The value of this number is **linearly dependent** on the input voltage value. Most microcontrollers nowadays internally have A/D converters connected to one or more input pins. Some of the most important parameters of A/D converters are **conversion time** and **resolution**. Conversion time determines how fast can an analog voltage be represented in form of a digital number. This is an important parameter if you need fast data acquisition. The other parameter is resolution. Resolution represents the number of discrete steps that supported voltage range can be divided into. It determines the sensitivity of the A/D converter.

Resolution is represented in maximum number of bits that resulting number occupies. Most PIC[®] microcontrollers have 12-bit resolution, meaning that maximum value of conversion can be represented with 12 bits, which converted to integer is $2^{12}=4096$. This means that supported voltage range, for example from 0-5V, can be divided into 4096 discrete steps of about 1.22mV. We gave you the possibility to set microcontroller voltage reference to 4.096V DC by putting jumper **J10 (RB0/VREF+)** to 4.096V position, **Figure 17-2**. This can be done **only when the power supply is 5V (jumper J16 in 5V position)**. In that case discrete steps are 1mV. When using voltage reference module, make sure to disconnect other peripherals from RB0 pin. EasyPIC[™] v7 for dsPIC30[®] provides an interface in form of potentiometer for simulating analog input voltages that can be routed to any of the 7 supported analog input pins.

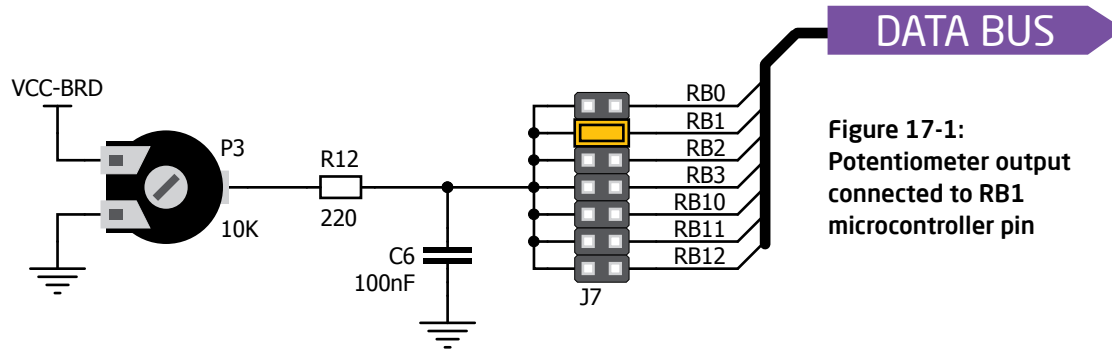
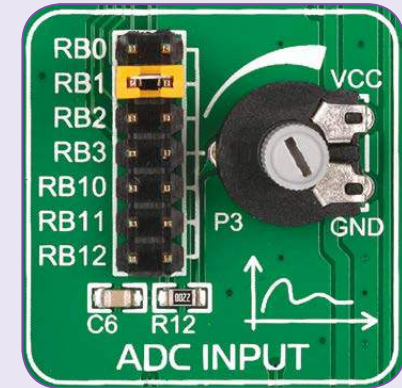

Figure 17-1:
Potentiometer output connected to RB1 microcontroller pin

Enabling ADC inputs



In order to connect the output of the potentiometer **P3** to **RB0, RB1, RB2, RB3, RB10, RB11** or **RB12** analog microcontroller inputs, you have to place the jumper **J7** in the desired position. By moving the potentiometer knob, you can create voltages in range from **GND** to **VCC-BRD**.

In order to set microcontroller voltage reference, you must place jumper **J10 (RB0/VREF+)** to appropriate position. Use 4.096 position **ONLY** when the jumper **J16** is in 5V position.

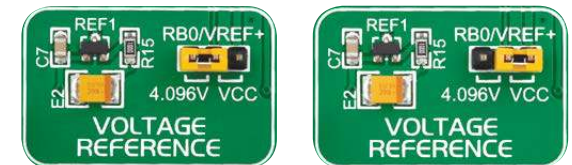
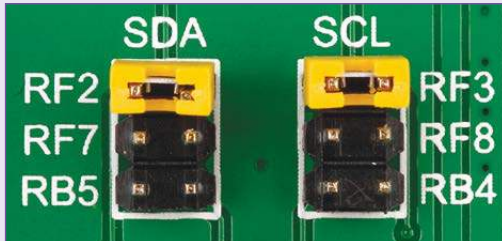

Figure 17-2: use jumper **J10** to set microcontroller voltage reference to 4.096V or VCC position

I²C EEPROM



Enabling I²C EEPROM



In order to connect I²C EEPROM to the microcontroller you must place **J14 (SCL)** and **J15 (SDA)** jumpers in appropriate position. **1kΩ** pull-up resistors necessary for I²C communication are already provided on **SDA** and **SCL** lines. Prior to using EEPROM in your application, make sure to disconnect other peripherals, LEDs and additional pull-up or pull-down resistors from the interface lines in order not to interfere with signal/data integrity.

EEPROM is short for **Electrically Erasable Programmable Read Only Memory**. It is usually a secondary storage memory in devices containing data that is retained even if the device loses power supply. Because of the ability to alter single bytes of data, EEPROM devices are used to store personal preference and configuration data in a wide spectrum of consumer, automotive, telecommunication, medical, industrial, and PC applications.

EasyPIC™ v7 for dsPIC30® supports serial EEPROM which uses **I²C communication interface** and has **1024 bytes** of available memory. Board contains socket for serial EEPROMs in DIP8 packaging, so you can easily exchange it with different memory size EEPROM IC. EEPROM itself supports single byte or 16-byte (page) write and read operations. Data rate is 400 kHz for both 3.3V and 5V power supply.

What is I²C?

I²C is a multi-master serial single-ended bus that is used to attach low-speed peripherals to computer or embedded systems. I²C uses only two open-drain lines, **Serial Data Line (SDA)** and **Serial Clock (SCL)**, pulled up with resistors. **SCL** line is driven by a master, while **SDA** is used as bidirectional line either by master or slave device. Up to 112 slave devices can be connected to the same bus. Each slave must have a unique address.

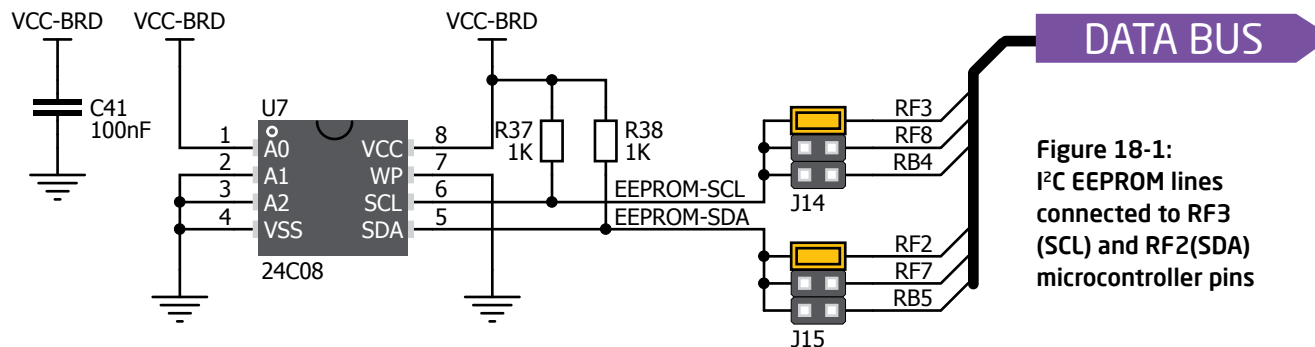
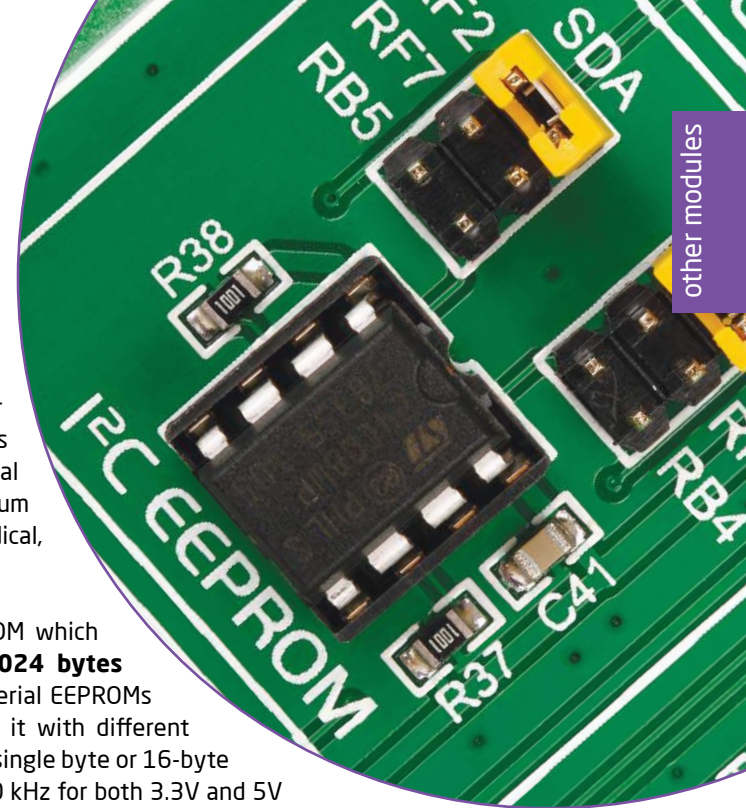
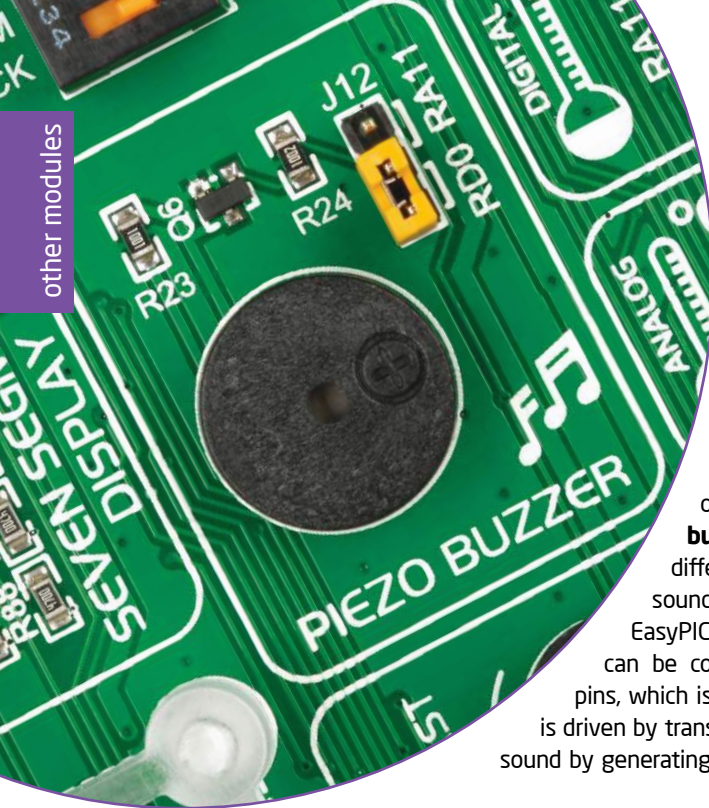

Figure 18-1:
I²C EEPROM lines
connected to RF3
(SCL) and RF2(SDA)
microcontroller pins





Piezo Buzzer

Piezo electricity is the charge which accumulates in certain solid materials in response to mechanical pressure, but also providing the charge to the piezoelectric material causes it to physically deform. One of the most widely used applications of piezo electricity is the production of sound generators, called piezo buzzers. **Piezo buzzer** is an electric component that comes in different shapes and sizes, which can be used to create sound waves when provided with analog electrical signal. EasyPIC™ v7 for dsPIC30® comes with piezo buzzer which can be connected either to **RDO** or **RA11** microcontroller pins, which is determined by the position of **J12** jumper. Buzzer is driven by transistor **Q6** (Figure 19-1). Microcontrollers can create sound by generating a PWM (Pulse Width Modulated) signal - a **square**

wave signal, which is nothing more than a sequence of logic zeros and ones. Frequency of the square signal determines the pitch of the generated sound, and duty cycle of the signal can be used to increase or decrease the volume in the range from 0% to 100% of the duty cycle. You can generate PWM signal using hardware capture-compare module, which is usually available in most microcontrollers, or by writing a custom software which emulates the desired signal waveform.

Supported sound frequencies

Piezo buzzer's resonant frequency (where you can expect it's best performance) is **3.8kHz**, but you can also use it to create sound in the range between **2kHz** and **4kHz**.

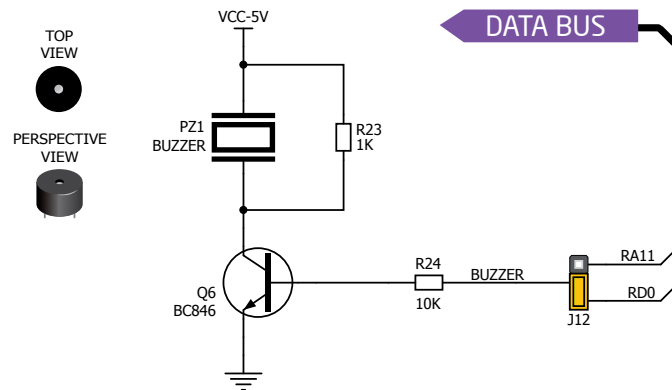

Figure 19-1: Piezo buzzer connected to RDO microcontroller pin

Enabling Piezo Buzzer

In order to use the on-board Piezo Buzzer in your application, you first have to connect the transistor driver of piezo buzzer to the appropriate microcontroller pin. This is done using jumper **J12**. You can place the jumper in two positions, thus connecting the buzzer driver to either **RDO** or **RA11** microcontroller pin.



Figure 19-2: Use jumper J12 to connect Piezo buzzer on RDO or RA11 pin



Freq = 3kHz, Duty Cycle = 50%



Freq = 3kHz, Volume = 50%

Freq = 3kHz, Duty Cycle = 80%



Freq = 3kHz, Volume = 80%

Freq = 3kHz, Duty Cycle = 20%



Freq = 3kHz, Volume = 20%

How to make it sing?

Buzzer starts "singing" when you provide PWM signal from the microcontroller to the buzzer driver. The pitch of the sound is determined by the frequency, and amplitude is determined by the duty cycle of the PWM signal.

Additional GNDs

EasyPIC™ v7 for dsPIC30® contains three **GND pins** located in different sections of the board, which allow you to easily connect oscilloscope GND reference when you monitor signals on microcontroller pins, or signals of on-board modules.

- 1 GND is located between RS-232 UART module and SW8 DIP switch.
- 2 GND is located on the left side of the PORTF I/O group
- 3 GND is located on the left side of the PORTD/A I/O group

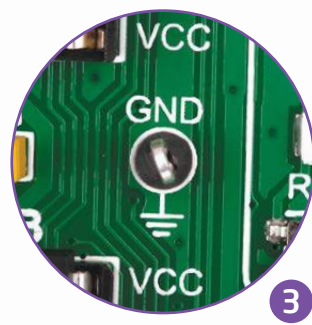
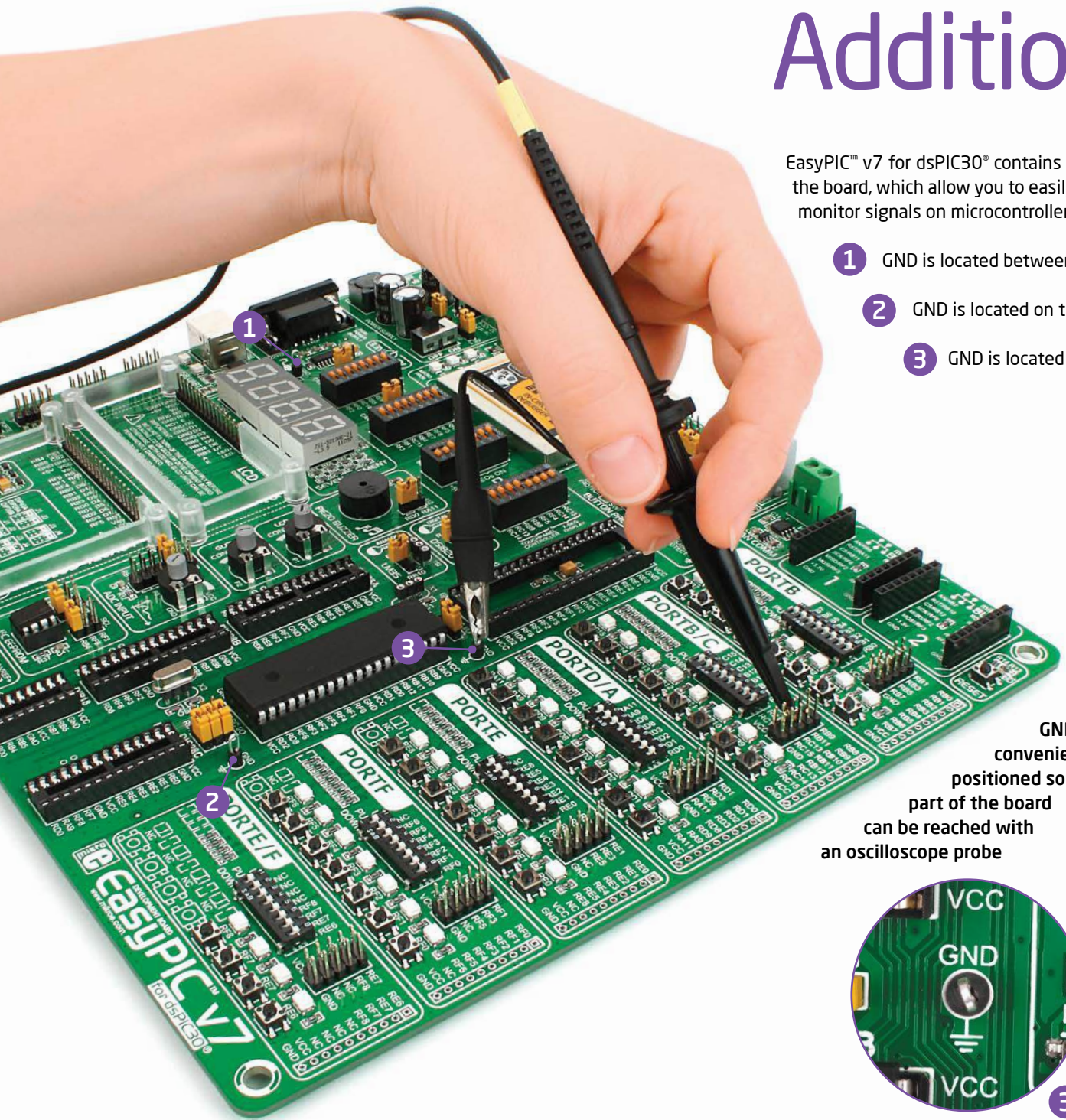

Figure 20-1:
3 oscilloscope
GND pins are
conveniently
positioned so each
part of the board
can be reached with
an oscilloscope probe

What's Next?

You have now completed the journey through each and every feature of **EasyPIC™ v7 for dsPIC30® board**. You got to know its modules, organization, supported microcontrollers, programmer and debugger. Now you are ready to start using your new board. We are suggesting several steps which are probably the best way to begin. We invite you to join thousands of users of EasyPIC™ brand. You will find very useful projects and tutorials and can get help from a large ecosystem of users. Welcome!

1

Compiler

You still don't have an appropriate compiler? Locate **dsPIC® compiler** that suits you best on our website:



www.mikroe.com/dspic/compilers/

Choose between **mikroC™**, **mikroBasic™** and **mikroPascal™**, and download fully functional demo version, so you can begin building your dsPIC® applications.

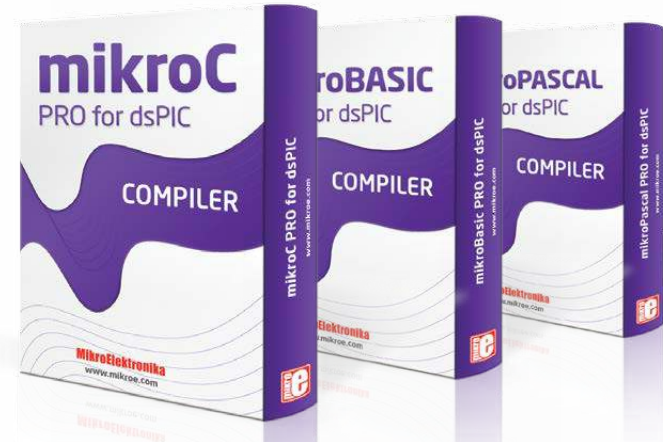

2

Projects

Once you have chosen your compiler, and since you already got the board, you are ready to start writing your first projects. We have equipped our compilers with dozens of examples that demonstrate the use of each and every feature of the **EasyPIC™ v7 for dsPIC30® board**, and all of our accessory boards as well. This makes an excellent starting point for your future projects. Just load the example, read well commented code, and see how it works on hardware. Browse through the compiler **Examples** path to find the following folder:



www.mikroe.com/easypic-dspic30/

3

Community

If you want to find answers to your questions on many interesting topics we invite you to visit our forum at <http://www.mikroe.com/forum> and browse through more than 150 thousand posts. You are likely to find just the right information for you. On the other hand, if you want to download free projects and libraries, or share your own code, please visit the **Libstock™ web site**. With user profiles, you can get to know other programmers, and subscribe to receive notifications on their code.



www.libstock.com/

4

Support

We all know how important it is that we can rely on someone in moments when we are stuck with our projects, facing a deadline, or when we just want to ask a simple, basic question, that's pulling us back for a while. We do understand how important this is to people and therefore our Support Department is one of the pillars upon which our company is based. MikroElektronika offers **Free Tech Support** to the end of product lifetime, so if something goes wrong, we are ready and willing to help!



www.mikroe.com/support/

DISCLAIMER

All the products owned by MikroElektronika are protected by copyright law and international copyright treaty. Therefore, this manual is to be treated as any other copyright material. No part of this manual, including product and software described herein, must be reproduced, stored in a retrieval system, translated or transmitted in any form or by any means, without the prior written permission of MikroElektronika. The manual PDF edition can be printed for private or local use, but not for distribution. Any modification of this manual is prohibited.

MikroElektronika provides this manual 'as is' without warranty of any kind, either expressed or implied, including, but not limited to, the implied warranties or conditions of merchantability or fitness for a particular purpose.

MikroElektronika shall assume no responsibility or liability for any errors, omissions and inaccuracies that may appear in this manual. In no event shall MikroElektronika, its directors, officers, employees or distributors be liable for any indirect, specific, incidental or consequential damages (including damages for loss of business profits and business information, business interruption or any other pecuniary loss) arising out of the use of this manual or product, even if MikroElektronika has been advised of the possibility of such damages. MikroElektronika reserves the right to change information contained in this manual at any time without prior notice, if necessary.

HIGH RISK ACTIVITIES

The products of MikroElektronika are not fault-tolerant nor designed, manufactured or intended for use or resale as on-line control equipment in hazardous environments requiring fail-safe performance, such as in the operation of nuclear facilities, aircraft navigation or communication systems, air traffic control, direct life support machines or weapons systems in which the failure of Software could lead directly to death, personal injury or severe physical or environmental damage ('High Risk Activities'). MikroElektronika and its suppliers specifically disclaim any expressed or implied warranty of fitness for High Risk Activities.

TRADEMARKS

The MikroElektronika name and logo, the MikroElektronika logo, mikroC™, mikroBasic™, mikroPascal™, mikroProg™, mikromedia™, EasyPIC™, EasyPIC PRO™, mikroBUS™ and Click boards™ are trademarks of MikroElektronika. All other trademarks mentioned herein are property of their respective companies.

All other product and corporate names appearing in this manual may or may not be registered trademarks or copyrights of their respective companies, and are only used for identification or explanation and to the owners' benefit, with no intent to infringe.

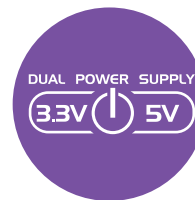
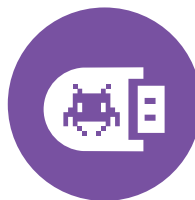

If you want to learn more about our products, please visit our web site at www.mikroe.com

If you are experiencing some problems with any of our products or just need additional information, please place your ticket at www.mikroe.com/support/

If you have any questions, comments or business proposals, do not hesitate to contact us at office@mikroe.com

EasyPIC v7 for dsPIC30 Manual
ver. 1.01a



0 100000 025956