

Little Logic Guide



Gates
Configurables
Signal Switches
Translators



Little Logic Guide

Table of Contents

Introduction

As the world leader in logic, Texas Instruments (TI) offers a full spectrum of logic functions and technologies including BiCMOS, Bipolar, and the latest advanced CMOS families. TI offers the most advanced logic technology while still maintaining support for traditional logic products.

Our logic portfolio includes:

- Over 2000 functions
- Technologies from 0.8 V to 18 V
- Best in class End-of-Life policies

Overview	3
Little Logic Products by Performance	4
Logic Migration to 1.8-V Future	4
Performance Comparisons	4
Gate Functions	4
Signal Switches	5
Configurables	6
LV1T Translators	6
Packaging	7
Advanced Packaging	7
Little Logic Packaging	8
Little Logic Package Cross Reference	8
Selection Tables	9
Single-Gate Functions	9
Dual-Gate Functions	12
Triple-Gate Functions	14
Signal-Switch Functions	14
Configurable Functions	15
Voltage Translation Functions	15-16
Cross-Reference	17
Competitor Cross-Reference	17-22
Part Number Definition	23
Competitor Part Prefixes	23
Resources and Support	24
TI Worldwide Technical Support	24

Little Logic Guide

Overview

WIN not only today's race, but tomorrow's with TI Little Logic

Better engine, customer centric

With TI's broad technical experience and application support in logic, analog and mixed signal designs, we provide our customers with gate functions, buffers/registers, level translators and switches in state-of-the-art packaging. To better meet your growing needs, TI works closely with you to get your engine started.

Faster time-to-market, easy-to-use

Reaching faster time-to-market requires easier design routing and minimized development risk. Little Logic devices in TI's space saving packages are easy to implement, stay closer to the circuitry and help simplify board designs. Without time-consuming invention of new silicon, designers can reach better performance with ASIC designs by using Little Logic functions.

More performance, one-stop selection

TI's large portfolio includes single-, dual- and triple-gates of the most popular functions in space saving packages to allow you the space you need. By replacing multiple devices through single configurable functions, Little Logic helps to reduce inventory.

No pit-stop, ever

TI Logic's stable no end-of-life policy secures that all products in our portfolio will always be available. This means more than 10,000 devices are orderable to support the widest range of applications and end-equipment at any time you need them. Little Logic's stable delivery culture is nothing new; it has lasted for more than 40 years. We help you to keep going and solve delivery issues.

WIN with best-in-class support

For more information on TI's Little Logic, call your local TI Field Sales office, your authorized TI distributor, or visit us at www.ti.com/littlelogic.

TI Logic Forces:

- Worldwide #1 vendor in the logic market
- Broadest portfolio of function and package combinations
- No end-of-life policy, the product you need is always available
- Biggest capacity in the market, no delivery pit-stop
- Best-in-class support for easier and faster design

Before

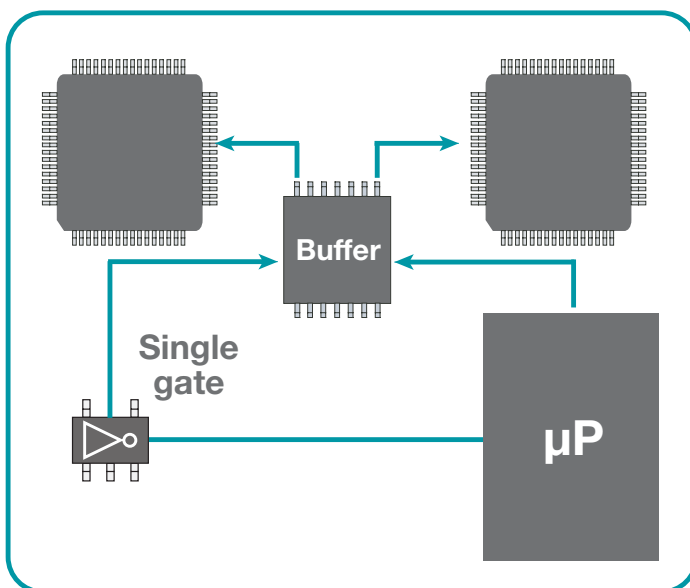

After

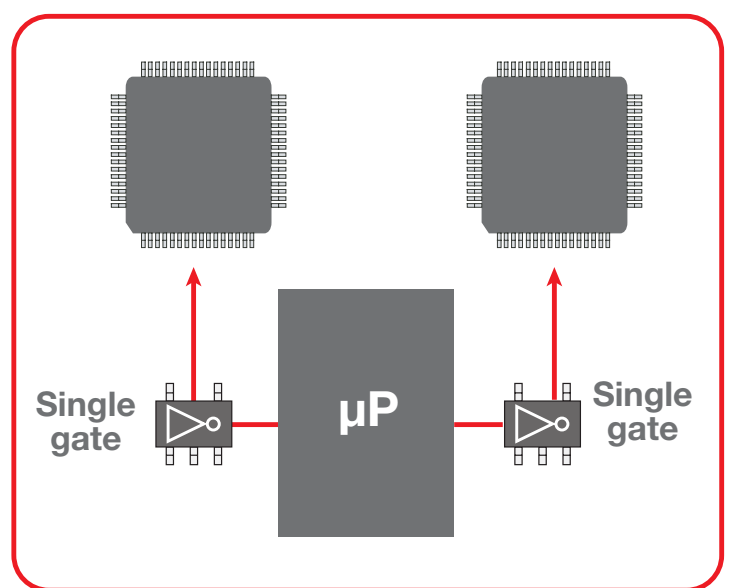

Little Logic Products by Performance

Logic Migration to 1.8-V Future

Keep the pace, even longer!

TI's numerous logic technologies with low power help designers extend battery life easily. With a varied operating voltage of 5.5 V down to 0.8 V, this graph shows how our devices work to keep your system running faster and longer.

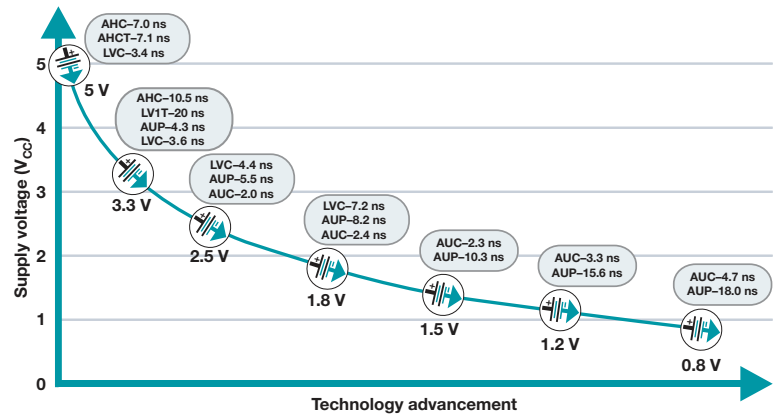

Performance Comparisons

Family	Operating Voltage Range (V)	Optimized Voltage (V)	Propagation Delay - t _{pd} (typ) (ns)	Output Drive (mA)	Input Tolerance (V)	I _{OFF} Protection
AUP	0.8 to 3.6	3.3	3.5	4	3.6	Yes
AUC	0.8 to 2.7	1.8	2.0	8	3.6	Yes
LVC	1.65 to 5.5	3.3	3.0	24	5.5	Yes
AHC	2.0 to 5.5	5.0	5.0	8	5.5	No
AHCT	4.5 to 5.5	5.0	5.0	8	5.5	No
CBT	4.5 to 5.5	5.0	0.25†	–‡	5.5	Yes
CBTD	4.5 to 5.5	5.0	0.25†	–‡	5.5	Yes
CBTLV	2.3 to 3.6	3.3	0.25†	–‡	3.6	Yes
CB3T	2.5 to 3.6	3.3	0.25†	–‡	5.5	Yes
LV1T	1.8 to 5.5	3.3	5	7	5.5	No

†The propagation delay is the calculated RC time constant of the typical on-state resistance of the switch and the specified load capacitance, when driven by an ideal voltage source (zero output impedance). The value listed is a maximum.

‡The FET switch has no output drive. The drive current at the output terminal is determined by the drive current of the device connected at the input terminal of the FET switch.

Gate Functions

Little Logic gates have all the features of their bigger cousins but in single, double, and triple gate functions. They cover the full range of voltages from 0.8 V to 5.5 V. They come in tiny packages making them excellent for handheld and any other equipment where space is a concern.

Standard gates include:

- 2- and 3-input gates
- Schmitt trigger input gates
- 3-state output buffer
- Open drain output
- Power off Hi-Z
- Buffer decoder and multiplexer
- Latch and flip-flop
- Dual power rail translator
- Gate translations

Advantages:

- I_{off} supports hot insertion
- I_{off} allows voltages on the inputs or outputs when V_{CC} is at 0 V
- Schmitt trigger input allows any slope on the rise and fall times

Translators

- LV1Txxx devices support both up and down translation.
- AUP1Txx devices support up translation
- Over voltage tolerant on input allows down translation
- Open drain output enables up or down translation

LV1T (up or down translation)

- Operating range 1.8 V to 5.5 V
- Drive 7 mA at 3.3 V
- Speed 50 MHz at 3.3 V typical

AUC (fastest speed)

- Operating range 0.8 V to 2.7 V
- Drive 5 mA at 1.5 V, 9 mA at 2.5 V
- Speed 350 MHz at 2.5 V typical

AHC (low power)

- Operating range 2.0 V to 5.5 V
- Drive 4 mA at 3.3 V, 8 mA at 5 V
- Speed 150 MHz at 5 V typical

LVC (high drive)

- Operating range 1.65 V to 5.5 V
- Drive 24 mA at 3.3 V, 32 mA at 5.0 V
- Speed 250 MHz at 5 V typical

AUP (lowest power – less than 0.9 μA at 3.3 V)

- Operating range 0.8 V to 3.6 V
- Drive 1.9 mA at 1.5 V, 4 mA at 3.3 V
- Speed 190 MHz at 3.3 V typical

Little Logic Products by Performance

Signal Switches

CBT (Bus switch)

- Operating range: 4-V to 5.5-V V_{CC}
- 0.25-ns typical t_{pd}

SN74CBT1G125 SN74CBT1G384
SN74CBTD1G125 SN74CBTD1G384

CBTLV (low-voltage bus switch)

- Operating range: 2.3-V to 3.6-V V_{CC}
- 0.25-ns typical t_{pd}

SN74CBTLV1G125

CB3T (low-voltage translation bus switch)

- Operating range: 2.3-V to 3.6-V V_{CC}
- 0.25-ns typical t_{pd}

SN74CB3T1G125

LVC (low-voltage CMOS)

- Operating range: 1.65-V to 5.5-V V_{CC}
- 3.0-ns typical t_{pd}

SN74LVC1G66 SN74LVC2G53
SN74LVC1G3157 SN74LVC2G66

AUC (advanced ultra-low-voltage CMOS)

- Operating range: 0.8-V to 2.7-V V_{CC}
- 2.0-ns typical t_{pd}

SN74AUC1G66 SN74AUC2G66
SN74AUC2G53

LVC1G66 TTL-to-LVTTL level shifter

The LVC1G66 can be used for simple translation from 5-V TTL levels to LVTTL. The control pin is tolerant to 5.5 V and, with a maximum r_{ON} of 15 Ω at $V_{CC} = 3.3$ V, the voltage drop across the switch is only 0.36 V with 24 mA of through current.

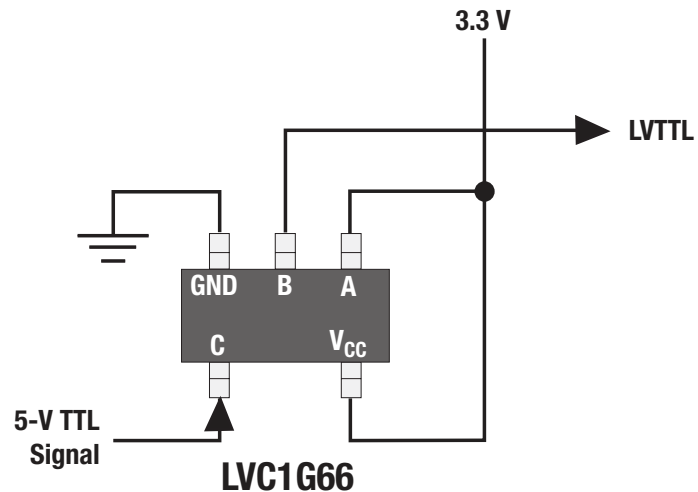

Visit www.ti.com/signalswitches for the application report, "Selecting the Right TI Signal Switch."

Little Logic Products by Performance

Configurables

The next-generation configurable devices in the Little Logic portfolio are the 1G97/98/99 functions in both the LVC and AUP technologies. By providing nine single-gate logic solutions in the 1G97/98 and 60 functions in the 1G99, the devices allow reductions in device inventory and simplify part management.

AUP (advanced ultra-low-power CMOS)

- Operating range: 0.8-V to 3.6-V V_{CC}
- 3.5-ns typical t_{pd}

SN74AUP1G57 SN74AUP1G58
 SN74AUP1G97 SN74AUP1G98
 SN74AUP1G99

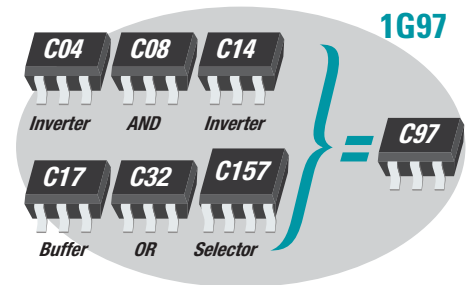

LVC (low-voltage CMOS)

- Operating range: 1.8-V to 5.5-V V_{CC}
- 3.0-ns typical t_{pd}

SN74LVC1G57 SN74LVC1G58
 SN74LVC1G97 SN74LVC1G98
 SN74LVC1G99

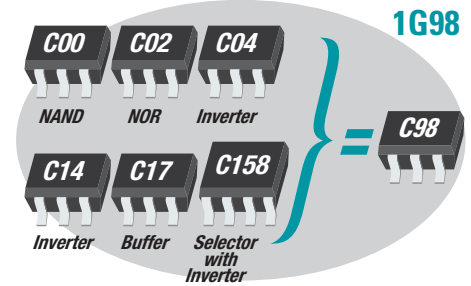

LV1T Translators

LV1T is the industry's first logic family of devices to fully integrate gate and up or down translation functionality operating from a single power supply. The LV1T family is available in nine different logic gates which are NAND & AND, NOR, OR, and XOR as well as several different buffer functions giving the customer a wide portfolio of logic gate functions to choose from.

Key Features

- Wide voltage range (1.8-5.0 V V_{CC})
- Up-translation mode
- Down-translation mode
- -40° to 125°C T_a operation

Benefits

- More than 50% board reduction by integration of the logic gate function and the up and down level shifter
- Widest voltage range of 1.8 V to 5.0 V
- Single power supply enables ease of routing
- Single logic product family for three design modes
- Extended temperature range

Applications

- Industrial - Metering
- Automotive - Infotainment
- Computing - Tablets, PC
- Personal Electronics - Smartphones, Wearables

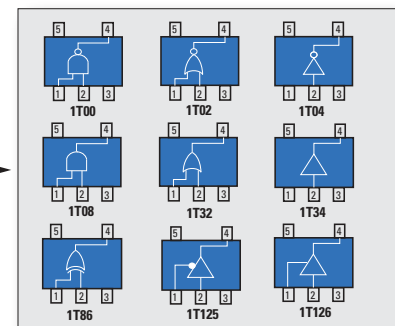

LV1T Family Functions

Packaging

Advanced Packaging

Electronic development continues to grow into new and innovative markets. Since innovation often means shrinking size, packaging finds itself in the forefront of enabling new features.

The ability to further customize packaging for medical, automotive and industrial applications is playing a bigger role meeting new desires and enabling solutions that were not possible in the past. Meeting today's dynamic market needs for advanced package solutions like size, thermal, electrical, and cost is more exciting than ever.

TI continues to invest in innovative solutions to be a leader in package development and offers two distinct package type solutions to address today's, as well as tomorrow's, market

needs. The broad TI NanoStar™ and μQFN package portfolio continues to offer more performance at a smaller size to solve design issues. TI has developed and qualified fine pitch options in both package nodes.

Our latest NanoStar™ additions include small, 0.3 mm pitch offerings such as 0.6 mm x 0.9 mm x 0.5 mm, 6-pin packages that are easy-to-use in smaller and thinner end applications.

The μQFN portfolio now includes the world's smallest 0.8 mm x 0.8 mm (0.5 mm pitch) package, called the DPW package.

μQFN (0.35mm pitch DSF package)

- Smallest line pitch, μQFN package in full production today
- Over 30% smaller than the original,
- 0.5 mm pitch μQFN package

μQFN (0.50 mm pitch DPW package)

- 56% Smaller than DRY (0.5 mm pitch) package
- 36% Smaller than DSF (0.35 mm pitch) package
- 0.5 mm pitch enables ease of manufacturing
- Sampling multiple functions across LVC/AUP
- Direct cross to NXP "GX" package

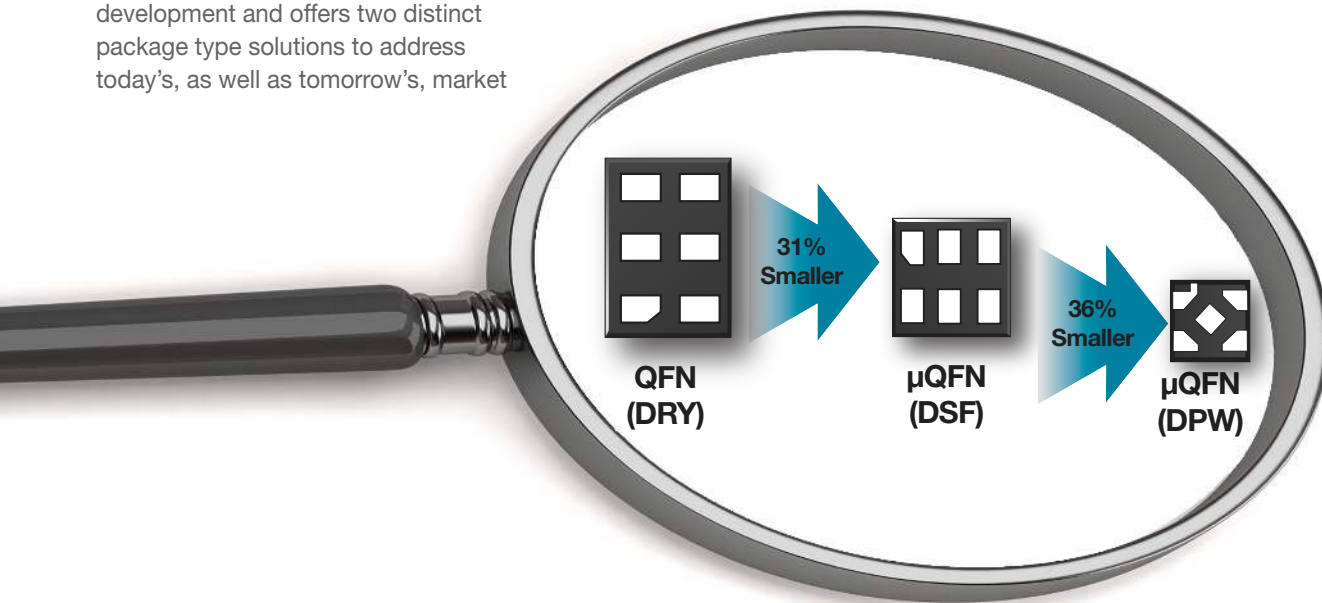

Little Logic Package Trend

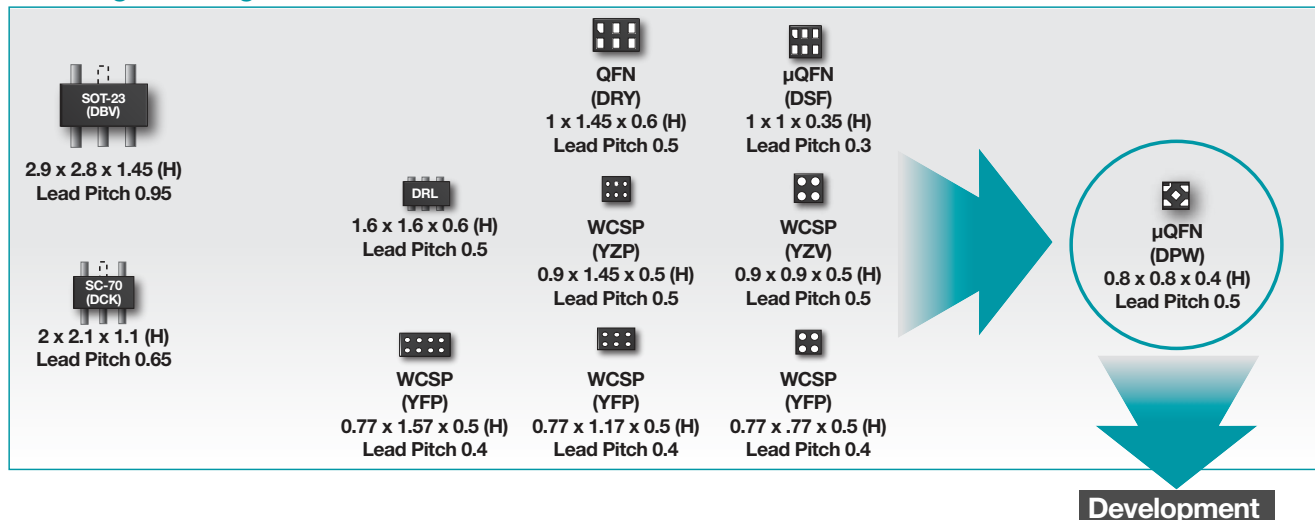

Packaging

Little Logic Packaging

YFP		YZP		DCK	DBV	DCT	DCU	DRY	DSF	DQE	RSE	YZV	DRL	DPW	
8-Ball	6-Ball	4-Ball	8-Ball	5-/6-Ball	5-/6-Pin	5-/6-Pin	8-Pin	8-Pin	6-Pin	6-Pin	8-Pin	8-Pin	4-Ball	5-/6-Pin	5-Pin

Package Sizes

Package	YFP	YFP	YFP	YZP	YZP	DCK	DBV	DCT	DCU	DRY	DSF	DQE	RSE	YZV	DRL	DPW
Pin	8-ball	6-ball	4-ball	8-ball	5-/6-ball	5-/6-pin	5-/6-pin	8-pin	8-pin	6-pin	6-pin	8-pin	8-pin	4-ball	5-/6-pin	5-pin
Height (inches) (mm)	0.0197	0.0197	0.0197	0.0197	0.0197	0.0374	0.0472	0.0512	0.0354	0.0157	0.0157	0.0146	0.0217	0.0197	0.0197	0.0157
	0.5	0.5	0.5	0.5	0.5	0.95	1.2	1.3	0.9	0.4	0.4	0.37	0.55	0.5	0.5	0.4
Area (sq. inches) (sq. mm)	0.002	0.001	0.001	0.003	0.002	0.007	0.013	0.018	0.010	0.002	0.002	0.002	0.003	0.001	0.003	0.001
	1.2089	0.9009	0.5929	1.71	1.305	4.2	8.12	11.8	6.2	1	1	1.4	2.25	0.81	1.92	0.64
Pitch (inches) (mm)	0.016	0.016	0.016	0.020	0.020	0.026	0.037	0.026	0.020	0.020	0.014	0.014	0.020	0.020	0.020	0.020
	0.4	0.4	0.4	0.5	0.5	0.65	0.95	0.65	0.5	0.5	0.35	0.35	0.5	0.5	0.5	0.5
Length (inches) (mm)	0.030	0.030	0.030	0.035	0.035	0.083	0.110	0.157	0.122	0.039	0.039	0.039	0.059	0.035	0.047	0.031
	0.77	0.77	0.77	0.9	0.9	2.1	2.8	4	3.1	1	1	1	1.5	0.9	1.2	0.8
Width (inches) (mm)	0.062	0.046	0.030	0.075	0.057	0.079	0.114	0.116	0.079	0.039	0.039	0.055	0.059	0.035	0.063	0.031
	1.57	1.17	0.77	1.9	1.45	2	2.9	2.95	2	1	1	1.4	1.5	0.9	1.6	0.8

Cross-Reference

Device	TI	Fairchild	ON	Toshiba	NXP	Pericom	STMicro
NanoStar™ Package WCSP	YZP	L6	—	—	—	—	—
SOT-23 (5-pin)	DBV	M5	DT	F	GV	TX	ST
SC-70 (5-pin)	DCK	P5	DF	FU	GW	CX	CT
SOT-23 (6-pin)	DBV	DT	—	—	GV	—	—
SC-70 (6-pin)	DCK	P6	DF	—	DW	—	—
SSOP (8-pin)	DCT	—	—	FU	—	—	—
VSSOP (8-pin)	DCU	K8	US	FK	DC	—	—
SOT563 (6-pin)	DRL	—	XV5T2	ESV	—	—	—
NanoStar (4-ball)	YZV	—	—	—	—	—	—
Micro QFN (8-pin)	DQE	—	—	—	—	—	—
Micro QFN (8-pin)	RSE	L8	MU	—	GM	—	—
Micro QFN (6-pin)	DRY	L6	AM	—	GM	—	—
Micro QFN (6-pin)	DSF	FH	CM	—	GF	—	—
Micro QFN (5-pin)	DPW	—	—	—	GX	—	—

TI package suffix decoder | YZP is NanoStar package | YZV is NanoStar package

DBV is 5- and 6-pin leadframe | DCK is 5- and 6-pin leadframe, slightly smaller than DBV

DCT is 8-pin leadframe | DCU is 8-pin leadframe, slightly smaller than DCT

DRL is 6-pin plastic small-outline

Selection Tables

Single-Gate Functions

Single-Gates

Function	Description	SOT-23 (DBV)	SC70 (DCK)	SM8 (DCT)	US8 (DCU)	X2SON (DQE)	SOT (DRL)	USON (DRY)	X2SON (DSF)	UQFN (RSE)	DSBGA (YFP)	DSBGA (YZP)	DSBGA (YZV)	μQFN (DPW)
LVC1G00	Single 2-Input NAND Gate	X	X				X	X	X			X		X
LVC1G02	Single 2-Input NOR Gate	X	X				X	X	X			X		X
LVC1G04	Single Inverter	X	X				X	X	X			X	X	X
LVC1Gu04	Single Unbuffered Inverter	X	X				X	X	X			X	X	
LVC1Gx04	Crystal Oscillator Driver	X	X				X							
LVC1G06	Single Inverter Buffer/Driver w/Open Drain Output	X	X				X	X	X			X	X	
LVC1G07	Single Buffer/Driver w/Open Drain Output	X	X				X	X	X			X	X	X
LVC1G08	Single 2-Input AND Gate	X	X				X	X	X			X		X
LVC1G10	Single 3-Input NAND Gate	X	X					X	X			X		
LVC1G11	Single 3-Input AND Gate	X	X					X	X			X		
LVC1G14	Single Schmitt Trigger Inverter	X	X				X	X	X			X	X	
LVC1G17	Single Schmitt Trigger Buffer	X	X				X	X	X			X	X	X
LVC1G18	1 of 2 Non-Inverting MUX	X	X					X	X			X		
LVC1G19	1 of 2 Decoder/Demultiplexer	X	X				X	X				X		
LVC1G27	Single 3-Input NOR Gate	X	X					X	X			X		
LVC1G29	2 of 3 Decoder/Demultiplexer			X	X							X		
LVC1G32	Single 2-Input OR Gate	X	X				X	X	X			X		X
LVC1G34	Single Buffer Gate	X	X				X	X	X		X	X	X	X
LVC1G38	Single 2-Input NAND Gate w/Open Drain Output	X	X					X	X			X		
LVC1G74	Single Positive-Edge-Triggered D-Type Flip-Flop			X	X	X				X				
LVC1G79	Single D-Type Flip-Flop	X	X				X					X		
LVC1G80	Single D-Type Flip-Flop	X	X									X		
LVC1G86	Single 2-Input Exclusive-OR Gate	X	X				X					X		
LVC1G123	Single Retrig Monostable w/Schmitt Trigger Inputs			X	X							X		
LVC1G125	Single Bus Buffer Gate w/3-State Output	X	X				X	X	X			X		X
LVC1G126	Single Bus Buffer Gate w/3-State Output	X	X				X	X	X			X		
LVC1G132	Single 2-input NAND gate with Schmitt Trigger input	X	X									X		
LVC1G139	2-Line to 4-Line Decoder			X	X							X		
LVC1G175	Single D-Type Flip-Flop w/Asynch Clr	X	X					X				X		
LVC1G240	Single Buffer/Driver w/3-State Output	X	X					X	X			X		
LVC1G332	Single 3-Input OR Gate	X	X					X	X			X		
LVC1G373	Single D-Type Latch w/3-State Output	X	X									X		
LVC1G374	Single D-Type Flip-Flop w/3-State Output	X	X									X		
LVC1G386	Single 3-Input Exclusive-OR Gate	X	X					X	X			X		
LVC1G0832	Single 3-Input Positive AND-OR Gate	X	X									X		
LVC1G3208	Single 3-Input Positive OR-AND Gate	X	X									X		
AHC1G00	Single 2-Input NAND Gate	X	X				X							
AHC1G02	Single 2-Input NOR Gate	X	X				X							
AHC1G04	Single Inverter	X	X				X							
AHC1GU04	Single Unbuffered Inverter	X	X				X							
AHC1G08	Single 2-Input AND Gate	X	X				X							
AHC1G09	Single 2-Input AND Gate w/ Open Drain Output	X	X											
AHC1G14	Single Schmitt Trigger Inverter	X	X				X							
AHC1G32	Single 2-Input OR Gate	X	X				X							
AHC1G86	Single 2-Input Exclusive-OR Gate	X	X				X							
AHC1G125	Single Bus Buffer Gate w/3-State Output	X	X				X							
AHC1G126	Single Bus Buffer Gate w/3-State Output	X	X				X							
AUC1G00	Single 2-Input NAND Gate	X	X				X					X		
AUC1G02	Single 2-Input NOR Gate	X	X				X					X		
AUC1G04	Single Inverter	X	X				X	X				X		
AUC1Gu04	Single Unbuffered Inverter	X	X									X		
AUC1G06	Single Inverter Buffer/Driver w/Open Drain Output	X	X									X		
AUC1G07	Single Buffer/Driver w/Open Drain Output	X	X									X		
AUC1G08	Single 2-Input AND Gate	X	X				X					X		
AUC1G14	Single Schmitt Trigger Inverter	X	X									X		
AUC1G17	Single Schmitt Trigger Buffer	X	X				X					X		
AUC1G19	1 of 2 Decoder/Demultiplexer	X	X				X					X		
AUC1G32	Single 2-Input OR Gate	X	X				X					X		
AUC1G74	Single Positive-Edge-Triggered D-Type Flip-Flop			X	X					X		X		

NOTE: Visit www.ti.com/littlelogic for product release updates.

Selection Tables

Single-Gate Functions

Single-Gates (continued)

Function	Description	SOT-23 (DBV)	SC70 (DCK)	SM8 (DCT)	US8 (DCU)	X2SON (DQE)	SOT (DRL)	USON (DRY)	X2SON (DSF)	UQFN (RSE)	DSBGA (YFP)	DSBGA (YZP)	DSBGA (YZV)	μQFN (DPW)
AUC1G79	Single D-Type Flip-Flop	X	X									X		
AUC1G80	Single D-Type Flip-Flop	X	X									X		
AUC1G86	Single 2-Input Exclusive-OR Gate	X	X									X		
AUC1G125	Single Bus Buffer Gate w/3-State Output	X	X									X		
AUC1G126	Single Bus Buffer Gate w/3-State Output	X	X									X		
AUC1G240	Single Buffer/Driver w/3-State Output	X	X									X		
AUP1G00	Single 2-Input NAND Gate	X	X				X	X	X		X	X		X
AUP1G02	Single 2-Input NOR Gate	X	X				X	X	X		X			X
AUP1G04	Single Inverter	X	X				X	X	X		X			X
AUP1G06	Single Inverter Buffer/Driver w/Open Drain Output	X	X				X	X	X		X			
AUP1G07	Single Buffer/Driver w/Open Drain Output	X	X				X	X	X		X	X		X
AUP1G08	Single 2-Input AND Gate	X	X				X	X	X		X	X		X
AUP1G14	Single Schmitt Trigger Inverter	X	X				X	X	X		X	X		
AUP1G17	Single Schmitt Trigger Buffer	X	X				X	X	X		X	X		
AUP1G32	Single 2-Input OR Gate	X	X				X	X	X		X	X		X
AUP1G34	Single Buffer Gate	X	X				X	X	X		X	X		X
AUP1G57	2-Input Non-Inverting MUX	X	X				X	X	X		X	X		
AUP1G74	Single Positive-Edge-Triggered D-Type Flip-Flop			X	X	X				X	X	X		
AUP1G79	Single D-Type Flip-Flop	X	X				X	X	X		X	X		
AUP1G80	Single D-Type Flip-Flop	X	X					X	X		X	X		
AUP1G125	Single Bus Buffer Gate w/3-State Output	X	X				X	X	X		X	X		
AUP1G126	Single Bus Buffer Gate w/3-State Output	X	X				X	X	X		X	X		
AUP1G240	Single Buffer/Driver w/3-State Output	X	X					X	X		X	X		
AHCT1G00	Single 2-Input Positive-NAND Gate	X	X											
AHCT1G02	Single 2-Input Positive-NOR Gate	X	X											
AHCT1G04	Single Inverter Gate	X	X											
AHCT1G08	Single 2-Input Positive-AND Gate	X	X				X							
AHCT1G14	Single Schmitt-Trigger Inverter Gate	X	X											
AHCT1G32	Single 2-Input Positive-OR Gate	X	X				X							
AHCT1G86	Single 2-Input Exclusive-OR Gate	X	X											
AHCT1G125	Single Bus Buffer Gate With 3-State Output	X	X				X							
AHCT1G126	Single Bus Buffer Gate With 3-State Output	X	X											
AUP1T00	2-Input NAND Gate		X											
AUP1T02	2-Input NOR Gate		X											
AUP1T04	Inverter		X											
AUP1T08	2-Input AND Gate		X											
AUP1T14	Schmitt Trigger Inverter		X											
AUP1T17	Schmitt Trigger Buffer		X											
AUP1T32	2-Input OR Gate Single-Bit		X											
AUP1T34	Buffer/Driver		X								X	X		
AUP1T50	Schmitt Trigger Buffer/Driver		X											
AUP1T57	Single-Supply Voltage-Level Translator with 9 Configurable Gate Logic Functions	X	X							X	X	X	X	
AUP1T58	Single-Supply Voltage-Level Translator with 9 Configurable Gate Logic Functions	X	X							X	X	X	X	
AUP1T86	2-Input Exclusive-OR Gate		X											

NOTE: Visit www.ti.com/littlelogic for product release updates.

Little Logic Guide

Single-Gate Functions

Function	Description	SOT-23 (DBV)	SC70 (DCK)	SM8 (DCT)	US8 (DCU)	SOT (DRL)	DSBGA (YZP)	USON (DRY)	X2SON (DSF)	DSBGA (YFP)
AUP1T87	2-Input Exclusive NOR Gate		X							
AUP1T97	Single-Supply Voltage-Level Translator with 9 Configurable Gate Logic Functions	X	X				X	X	X	X
AUP1T98	Single-Supply Voltage-Level Translator with 9 Configurable Gate Logic Functions	X	X				X	X	X	X
AUP1T157	2 to 1 Data Selector/Multiplexer		X							
AUP1T158	2-Input Multiplexer		X							

Function	Description	SOT-23 (DBV)	SC70 (DCK)	SM8 (DCT)	US8 (DCU)	SOT (DRL)	USON (DPK)	DSBGA (YZP)	USON (DRY)	X2SON (DSF)	DSBGA (YFP)
LV1T00	NAND Gate and/or Up/Down-Translator	X	X								
LV1T04	Inverter Buffer/Driver and/or Up/Down-Translator	X	X								
LV1T08	2-Input AND Gate and/or Up/Down-Translator	X	X								
LV1T02	2-Input NOR Gate and/or Up/Down-Translator	X	X								
LV1T32	2-Input OR Gate and/or Up/Down-Translator	X	X								
LV1T34	Single Buffer Gate	X	X								
LV1T125	Buffer/Driver w/3-State Output w/High Disabled and/or Up/Down-Translator	X	X								
LV1T126	Buffer/Driver w/3-State Outputs w/Low Disabled and/or Up/Down-Translator	X	X								
LV1T86	2-Input Exclusive-OR (XOR) Gate and/or Up/Down-Translator	X	X								

NOTE: Visit www.ti.com/littlelogic for product release updates.

Single-Gate Diagram

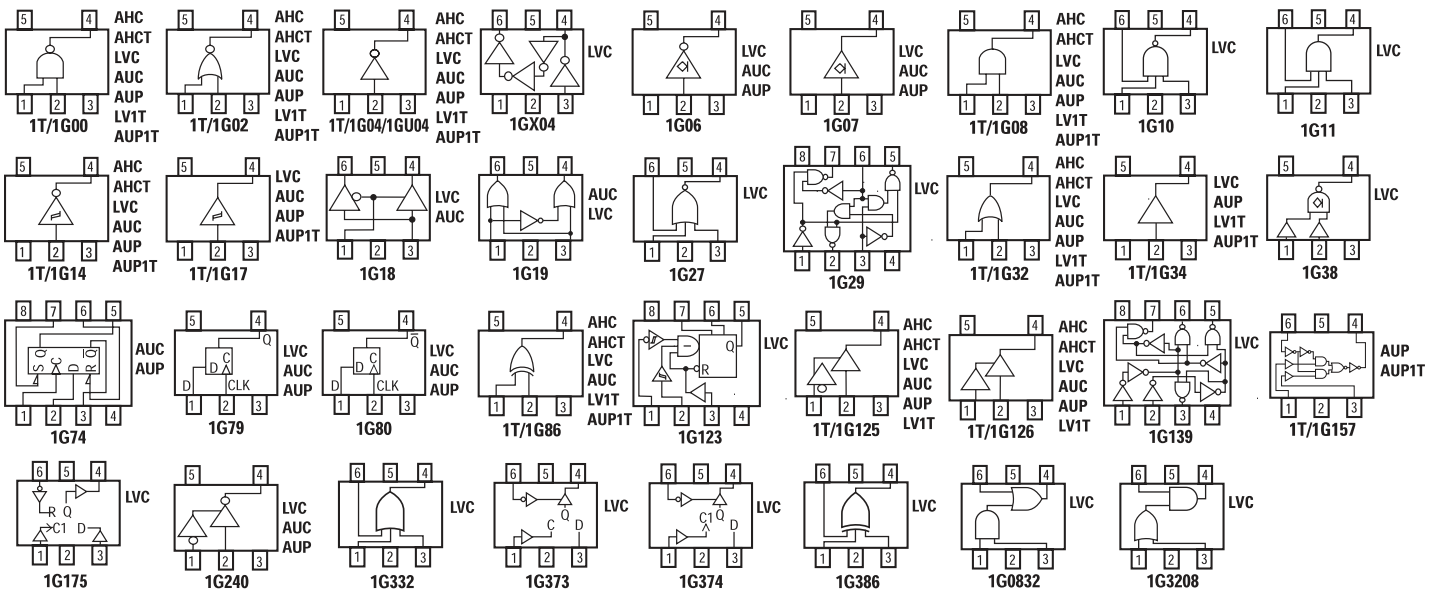

Selection Tables

Dual-Gate Functions

Dual-Gates

Function	Description	SOT-23 (DBV)-6	SC70 (DCK)	SM8 (DCT)	US8 (DCU)	SOT (DRL)	USON (DRY)	X2SON (DSF)	X2SON (DQE)	UQFN (RSE)	DSBGA (YFP)	DSBGA (YZP)
LVC2G00	Dual 2-Input NAND Gate			X	X							X
LVC2G02	Dual 2-Input NOR Gate			X	X							X
LVC2G04	Dual Inverter	X	X			X						X
LVC2GU04	Dual Unbuffered Inverter	X	X									X
LVC2G06	Dual Inverter w/Open Drain Output	X	X				X	X				X
LVC2G07	Dual Non-Inverter w/Open Drain Output	X	X				X	X				X
LVC2G08	Dual 2-Input AND Gate			X	X							X
LVC2G14	Dual Schmitt Inverter	X	X									X
LVC2G17	Dual Schmitt Trigger Input Buffers	X	X				X	X				X
LVC2G32	Dual 2-Input OR Gate			X	X							X
LVC2G34	Dual Non-Inverter	X	X			X						X
LVC2G38	Dual 2-Input NAND Gate w/Open Drain Output			X	X							X
LVC2G53	2:1 Analog Multiplexer/Demultiplexer			X	X							X
LVC2G79	Dual Positive-Edge-Triggered D-Type Flip-Flop			X	X							X
LVC2G80	Dual Positive-Edge-Triggered D-Type Flip-Flop			X	X							X
LVC2G86	Dual 2-Input Exclusive-OR Gate			X	X							X
LVC2G125	Dual Bus Buffer Gate w/3-State Outputs			X	X							X
LVC2G126	Dual Bus Buffer Gate w/3-State Outputs			X	X							X
LVC2G132	Dual 2-Input NAND Gate with Schmitt-Trigger Inputs			X	X							X
LVC2G157	Single 2 Line to 1 Line Data Selector/Multiplexer			X	X							X
LVC2G240	Dual Bus Buffer Gate w/3-State Outputs			X	X							X
LVC2G241	Dual Buffer/Driver w/3-State Outputs			X	X							X
AUC2G00	Dual 2-Input NAND Gate			X	X							X
AUC2G02	Dual 2-Input NOR Gate			X	X							X
AUC2G04	Dual Inverter	X	X									X
AUC2GU04	Dual Unbuffered Inverter	X	X							X		X
AUC2G06	Dual Inverter w/Open Drain Output	X	X									X
AUC2G07	Dual Non-Inverter w/Open Drain Output	X	X									X
AUC2G08	Dual 2-Input AND Gate			X	X							X
AUC2G32	Dual 2-Input OR Gate			X	X							X
AUC2G34	Dual Non-Inverter	X	X			X						X
AUC2G53	2:1 Analog Multiplexer/Demultiplexer			X	X							X
AUC2G79	Dual Positive-Edge-Triggered D-Type Flip-Flop			X	X							X
AUC2G80	Dual Positive-Edge-Triggered D-Type Flip-Flop			X	X							X
AUC2G86	Dual 2-Input Exclusive-OR Gate			X	X							X
AUC2G125	Dual Bus Buffer Gate w/3-State Outputs			X	X							X
AUC2G126	Dual Bus Buffer Gate w/3-State Outputs			X	X					X		X
AUC2G240	Dual Bus Buffer Gate w/3-State Outputs			X	X							X
AUC2G241	Dual Buffer/Driver w/3-State Outputs			X	X							X

NOTE: Visit www.ti.com/littlelogic for product release updates.

Selection Tables

Dual-Gate Functions

Dual-Gates (continued)

Function	Description	SOT-23 (DBV)-6	SC70 (DCK)	SM8 (DCT)	US8 (DCU)	SOT (DRL)	USON (DRY)	X2SON (DSF)	X2SON (DQE)	UQFN (RSE)	DSBGA (YFP)	DSBGA (YZP)
AUP2G00	Dual 2-Input NAND Gate				X				X	X	X	
AUP2G02	Dual 2-Input NOR Gate				X				X	X	X	
AUP2G04	Dual Inverter		X				X	X			X	
AUP2G06	Dual Inverter w/Open Drain Output		X				X	X			X	
AUP2G07	Dual Non-Inverter w/Open Drain Output		X				X	X			X	
AUP2G08	Dual 2-Input AND Gate				X				X	X	X	X
AUP2G14	Dual Schmitt Inverter		X				X	X			X	
AUP2G17	Dual Schmitt Trigger Input Buffers		X				X	X			X	
AUP2G32	Dual 2-Input OR Gate				X				X	X	X	
AUP2G34	Dual Non-Inverter		X				X	X			X	
AUP2G79	Dual Positive-Edge-Triggered D-Type Flip-Flop				X				X	X	X	
AUP2G80	Dual Positive-Edge-Triggered D-Type Flip-Flop				X				X	X	X	
AUP2G125	Dual Bus Buffer Gate w/3-State Outputs				X				X	X	X	X
AUP2G126	Dual Bus Buffer Gate w/3-State Outputs				X				X	X	X	X
AUP2G240	Dual Bus Buffer Gate w/3-State Outputs				X				X	X	X	
AUP2G241	Dual Buffer/Driver w/3-State Outputs				X				X	X	X	

NOTE: Visit www.ti.com/littlelogic for product release updates.

Dual-Gate Diagram

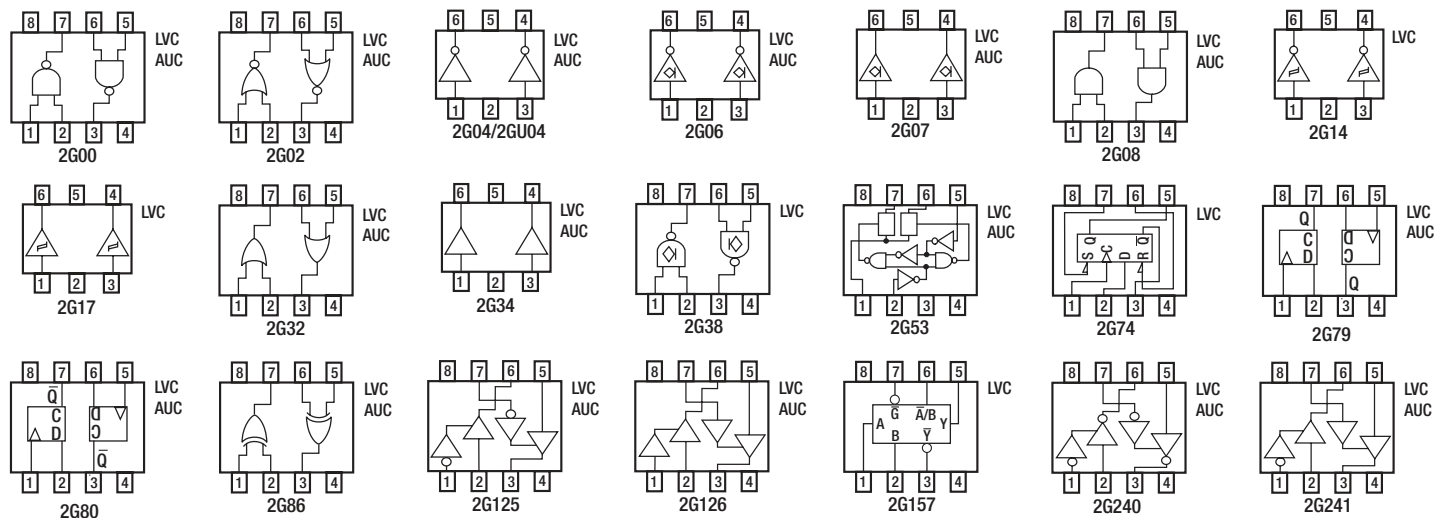

Selection Tables

Triple-Gate Functions

Triple-Gates

Function	Description	SM8 (DCT)	US8 (DCU)	X2SON (DQE)	UQFN (RSE)	DSBGA (YFP)	DSBGA (YZP)
LVC3G04	Triple Inverter Gate	X	X				X
LVC3GU04	Triple Inverter Gate (Unbuffered)	X	X				X
LVC3G06	Triple Inverter Buffer/Driver w/Open Drain Output	X	X				X
LVC3G07	Triple Buffer/Driver w/Open Drain Output	X	X				X
LVC3G14	Triple Schmitt Trigger Inverter	X	X				X
LVC3G17	Triple Schmitt Trigger Buffer	X	X				X
LVC3G34	Triple Buffer Gate	X	X				X
<hr/>							
AUP3G04	Triple Inverter Gate		X	X	X	X	
AUP3G06	Triple Inverter Buffer/Driver w/Open Drain Output		X	X	X	X	
AUP3G07	Triple Buffer/Driver w/Open Drain Output		X	X	X	X	
AUP3G14	Triple Schmitt Trigger Inverter		X	X	X	X	
AUP3G17	Triple Schmitt Trigger Buffer		X	X	X	X	
AUP3G34	Triple Buffer Gate		X	X	X	X	

Triple-Gate Diagram

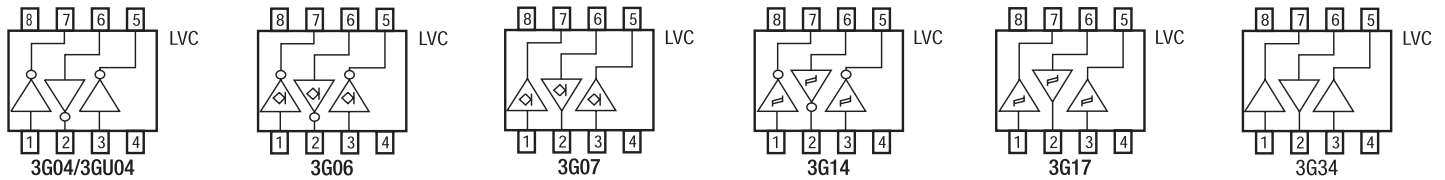

Signal-Switch Functions

Signal-Switch

Function	Description	SOT-23 (DBV)-5	SC70 (DCK)-5	SOT-23 (DBV)-6	SC70 (DCK)-6	SM8 (DCT)	US8 (DCU)	SOT (DRL)	DSBGA (YZP)	SON (DRY)	SON (DSF)
CBT1G125	Single FET Bus Switch	X	X								
CBT1G384	Single FET Bus Switch	X	X								
CB3T1G125	Single FET Bus Switch	X	X								
CBTD1G125	Single FET Bus Switch	X	X								
CBTD1G384	Single FET Bus Switch	X	X								
CBTLV1G125	Single FET Bus Switch	X	X								
<hr/>											
LVC1G66	Single Analog Switch	X	X					X	X	X	X
LVC1G3157	Single-Pole, Double-Throw (SPDT) Analog Switch	X	X					X	X	X	X
LVC2G53	Single-Pole, Double-Throw (SPDT) Analog Switch					X	X		X		
LVC2G66	Dual Analog Switch					X	X		X		
<hr/>											
AUC1G66	Dual Analog Switch	X	X						X		
AUC2G53	Single-Pole, Double-Throw (SPDT) Analog Switch					X	X		X		
AUC2G66	Dual Analog Switch					X	X		X		

NOTE: Visit www.ti.com/littlelogic for product release updates.

Signal-Switch Diagram

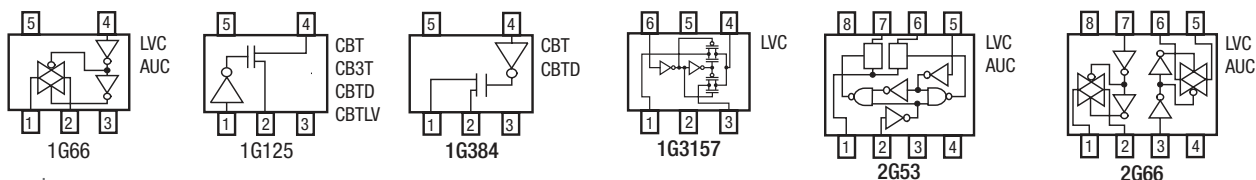

Selection Tables

Configurable Functions

Configurables

Function	Description	SOT-23 (DBV)-6	US8 (DCU)	SOT (DRL)	DSBGA (YZP)	DSBGA (YFP)	SC70 (DCK)	USON (DRY)	SM8 (DCT)	SON (DSF)
LVC1G57	Configurable Multiple-Function Gate	X		X	X		X	X		X
LVC1G58	Configurable Multiple-Function Gate	X		X	X		X	X		X
LVC1G97	Configurable Multiple-Function Gate	X		X	X		X	X		X
LVC1G98	Configurable Multiple-Function Gate	X		X	X		X	X		X
LVC1G99	Ultra-Configurable Multiple-Function Gate		X		X				X	
AUP1G57	Configurable Multiple-Function Gate	X		X	X	X	X	X		X
AUP1G58	Configurable Multiple-Function Gate	X		X	X	X	X	X		X
AUP1G97	Configurable Multiple-Function Gate	X		X	X	X	X	X		X
AUP1G98	Configurable Multiple-Function Gate	X		X	X	X	X	X		X
AUP1G99	Ultra-Configurable Multiple-Function Gate		X		X				X	

NOTE: Visit www.ti.com/littlelogic for product release updates.

Configurable Diagrams

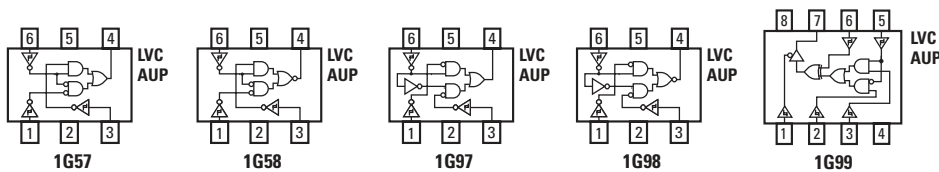

Voltage Translation Functions

Single-Supply

Function	Description	SOT-23 (DBV)	SC70 (DCK)	SM8 (DCT)	US8 (DCU)	SOT (DRL)	DSBGA (YZP)	USON (DRY)	X2SON (DSF)	DSBGA (YFP)
AUP1T00	2-Input NAND Gate		X							
AUP1T02	2-Input NOR Gate		X							
AUP1T04	Inverter		X							
AUP1T08	2-Input AND Gate		X							
AUP1T14	Schmitt Trigger Inverter		X							
AUP1T17	Schmitt Trigger Buffer		X							
AUP1T32	2-Input OR Gate Single-Bit		X							
AUP1T34	Buffer/Driver		X					X	X	
AUP1T50	Schmitt Trigger Buffer/Driver		X							
AUP1T57	Single-Supply Voltage-Level Translator with 9 Configurable Gate Logic Functions	X	X				X	X	X	X
AUP1T58	Single-Supply Voltage-Level Translator with 9 Configurable Gate Logic Functions	X	X				X	X	X	X
AUP1T86	2-Input Exclusive-OR Gate		X							
AUP1T87	2-Input Exclusive NOR Gate		X							
AUP1T97	Single-Supply Voltage-Level Translator with 9 Configurable Gate Logic Functions	X	X				X	X	X	X
AUP1T98	Single-Supply Voltage-Level Translator with 9 Configurable Gate Logic Functions	X	X				X	X	X	X
AUP1T157	2 to 1 Data Selector/Multiplexer		X							
AUP1T158	2-Input Multiplexer		X							

NOTE: Visit www.ti.com/littlelogic for product release updates.

Selection Tables

Voltage Translation Functions

Single-Supply (continued)

Function	Description	SOT-23 (DBV)	SC70 (DCK)	SM8 (DCT)	US8 (DCU)	SOT (DRL)	USON (DPK)	DSBGA (YZP)	USON (DRY)	X2SON (DSF)	DSBGA (YFP)
LV1T00	NAND Gate and/or Up/Down-Translator	X	X								
LV1T04	Inverter Buffer/Driver and/or Up/Down-Translator	X	X								
LV1T08	2-Input AND Gate and/or Up/Down-Translator	X	X								
LV1T02	2-Input NOR Gate and/or Up/Down-Translator	X	X								
LV1T32	2-Input OR Gate and/or Up/Down-Translator	X	X								
LV1T34	Single Buffer Gate	X	X								
LV1T125	Buffer/Driver w/3-State Output w/High Disabled and/or Up/Down-Translator	X	X								
LV1T126	Buffer/Driver w/3-State Outputs w/Low Disabled and/or Up/Down-Translator	X	X								
LV1T86	2-Input Exclusive-OR (XOR) Gate and/or Up/Down-Translator	X	X								

Dual-Supply

Function	Description	SOT-23 (DBV)	SC70 (DCK)	SM8 (DCT)	US8 (DCU)	SOT (DRL)	USON (DPK)	DSBGA (YZP)	USON (DRY)	X2SON (DSF)	DSBGA (YFP)
AVC1T45	Dual-Supply Transceiver w/Configurable Voltage Translation and 3-State Outputs	X	X			X		X			
AVC2T45	Dual-Bit Dual-Supply Transceiver w/Configurable Voltage Translation and 3-State Outputs			X	X			X			
AVCH1T45	Dual-Supply Transceiver w/Configurable Voltage Translation and 3-State Outputs	X	X					X			
AVCH2T45	Dual-Bit Dual-Supply Transceiver w/Configurable Voltage Translation and 3-State Outputs			X	X			X			
LVC1T45	Dual-Supply Transceiver w/Configurable Voltage Translation and 3-State Outputs	X	X			X		X			
LVC2T45	Dual-Bit Dual-Supply Transceiver w/Configurable Voltage Translation and 3-State Outputs			X	X			X			

NOTE: Visit www.ti.com/littlelogic for product release updates.

Translation Diagrams

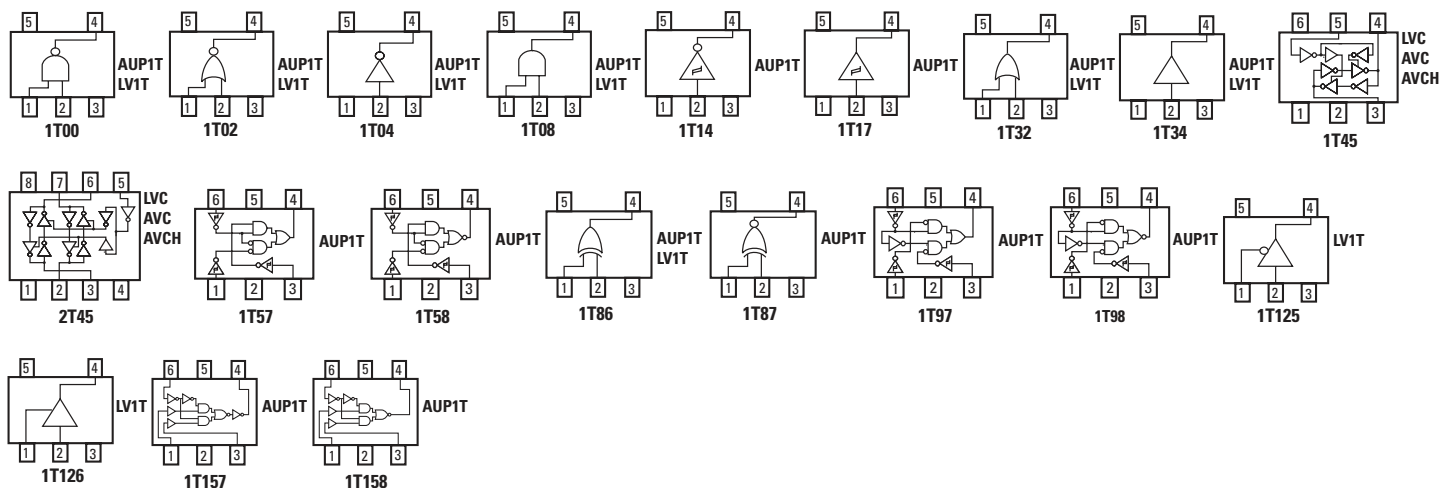

Cross-Reference

Competitor Cross-Reference

LVC Devices

Function	Description	TI (LVC)	Fairchild (NC7S/WZ)	ON (SZ)	ON (NLU)	ON (NLX)	Toshiba (TC7S/WZ)	NXP (LVC)	Pericom (STX)	STMicro (LX)
Single Gate										
1G00	Single 2-Input NAND	SN74LVC1G00	NC7SZ00	NL17SZ00	NLU1G00	—	TC7SZ00	74LVC1G00	—	74LX1G00
1G02	Single 2-Input NOR	SN74LVC1G02	NC7SZ02	NL17SZ02	—	—	TC7SZ02	74LVC1G02	PI74STX1G02	74LX1G02
1G04	Single Inverter	SN74LVC1G04	NC7SZ04	NL17SZ04	NLU1G04	—	TC7SZ044	74LVC1G04	—	74LX1G04
1GU04	Single Inverter (Unbuffered)	SN74LVC1GU04	NC7SZU04	NL17SZU04	NLU1GU04	—	TC7SZU04	74LVC1GU04	PI74STX1GU04	74LX1GU04
1GX04	Crystal Driver	SN74LVC1GX04	—	—	—	—	—	74LVC1GX04	—	—
1G06	Single Inverter Buffer/Driver w/Open Drain Output	SN74LVC1G06	—	NL17SZ06	—	—	—	74LVC1G06	—	—
1G07	Single Buffer/Driver w/Open Drain Output	SN74LVC1G07	—	NL17SZ07	NLU1G07	—	TCSZ07	74LVC1G07	—	74LX1G07
1G08	Single 2-Input AND	SN74LVC1G08	NC7SZ08	NL17SZ08	NLU1G08	—	TC7SZ08	74LVC1G08	PI74STX1G08	74LX1G08
1G10	Single 3-Input NAND	SN74LVC1G10	NC7SZ10	—	—	—	—	74LVC1G10	—	—
1G11	Single 3-Input AND	SN74LVC1G11	NC7SZ11	—	—	—	—	74LVC1G11	—	—
1G14	Single Inverter w/Schmitt Trigger	SN74LVC1G14	NC7SZ14	NL17SZ14	NLU1G14	—	TC7SZ14	74LVC1G14	—	74LX1G14
1G17	Single Buffer w/Schmitt Trigger	SN74LVC1G17	—	NL17SZ17	—	—	—	74LVC1G17	—	—
1G18	1 of 2 Non-Inverting MUX	SN74LVC1G18	NC7SZ18	NL7SZ18	—	—	—	74LVC1G18	—	—
1G19	1 of 2 Decoder	SN74LVC1G19	NC7SZ19	NL7SZ19	—	—	—	74LVC1G19	—	—
1G27	Single 3-Input NOR	SN74LVC1G27	NC7SZ27	—	—	—	—	—	—	—
1G29	2 of 3 Decoder/Demultiplexer	SN74LVC1G29	—	—	—	—	—	—	—	—
1G32	Single 2-Input OR	SN74LVC1G32	NC7SZ32	NL17SZ32	NLU1G32	—	TC7SZ126	74LVC1G32	—	74LX1G32
1G34	Single Buffer Gate	SN74LVC1G34	—	NL17SZ16	—	—	TC7SZ32	74LVC1G34	—	74LX1G70
1G38	Single 2-Input NAND w/Open Drain Output	SN74LVC1G38	NC7SZ38	—	—	—	TC7SH34	74LVC1G38	—	—
1G79	Single D-Type Flip-Flop	SN74LVC1G79	—	—	—	—	TC7SZ38	74LVC1G79	—	—
1G80	Single D-Type Flip-Flop	SN74LVC1G80	—	—	—	—	—	74LVC1G80	—	—
1G86	Single 2-Input Exclusive-OR	SN74LVC1G86	NC7SZ86	NL17SZ86	NLU1G86	—	—	74LVC1G86	—	74LX1G86
1G123	Single Retrig Monostable Multivibrator	SN74LVC1G123	—	—	—	—	TC7SZ86	—	—	—
1G125	Single-Bus Buffer Gate w/3-State	SN74LVC1G125	NC7SZ125	NL17SZ125	—	—	—	74LVC1G125	—	74LX1G125
1G126	Single-Bus Buffer Gate w/3-State	SN74LVC1G126	NC7SZ126	NL17SZ126	—	—	TC7SZ125	74LVC1G126	PI74STX1G126	74LX1G126
1G132	Single 2-Input NAND w/Schmitt Trigger	SN74LVC1G132	—	—	—	—	TC7SZ126	—	—	74LX1G132
1G139	2-Line to 4-Line Decoder	SN74LVC1G139	—	—	—	—	—	—	—	—
1G175	Single D-Type Flip-Flop w/Asynch Clear	SN74LVC1G175	NC7SZ175	—	—	—	—	74LVC1G175	—	—
1G240	Single Bus Buffer Gate w/3-State	SN74LVC1G240	—	—	—	—	—	—	—	—
1G332	Single 3-Input OR	SN74LVC1G332	NC7SZ332	—	—	—	—	74LVC1G332	—	—

NOTE: Visit www.ti.com/littlelogic for product release updates.

Cross-Reference

Competitor Cross-Reference

LVC Devices (continued)

Function	Description	TI (LVC)	Fairchild (NC7S/WZ)	ON (SZ)	ON (NLU)	ON (NLX)	Toshiba (TC7S/WZ)	NXP (LVC)	Pericom (STX)	STMicro (LX)
Single Gate										
1G373	Single D-Type Latch w/3-State	SN74LVC1G373	NC7SZ373	—	—	—	—	—	—	—
1G374	Single D-Type Flip-Flop w/3-State	SN74LVC1G374	NC7SZ374	—	—	—	—	—	—	—
1G386	Single 3-Input Exclusive-OR	SN74LVC1G386	NC7SZ386	—	—	—	—	74LVC1G386	—	—
1G0832	Single 3-Input Positive AND-OR Gate	SN74LVC1G0832	—	—	—	—	—	—	—	—
1G3208	Single 3-Input Positive OR-AND Gate	SN74LVC1G3208	—	—	—	—	—	—	—	—
Dual Gate										
2G0	Dual 2-Input NAND	SN74LVC2G00	NC7WZ00	NL27WZ00	—	—	TC7WZ00	74LVC2G00	—	—
2G02	Dual 2-Input NOR	SN74LVC2G02	NC7WZ02	NL27WZ02	—	—	TC7WZ02	74LVC2G02	—	—
2G04	Dual Inverter	SN74LVC2G04	NC7WZ04	NL27WZ04	NLU2G04	NLX2G04	—	74LVC2G04	—	—
2GU04	Dual Inverter (Unbuffered)	SN74LVC2GU04	NC7WZU04	NL27WZU04	NLU2GU04	NLX2GU04	—	74LVC2GU04	—	—
2G06	Dual Inverter Buffer Driver w/Open Drain Output	SN74LVC2G06	—	NL27WZ06	NLU2G06	NLX2G06	—	74LVC2G06	—	—
2G07	Dual-Buffer Driver w/Open Drain Output	SN74LVC2G07	NC7WZ07	NL27WZ07	NLU2G07	NLX2G07	—	74LVC2G07	—	—
2G08	Dual 2-Input AND	SN74LVC2G08	NC7WZ08	NL27WZ08	—	NLX2G08	TC7WZ08	74LVC2G08	PI74STX2G08	—
2G14	Dual Inverter w/Schmitt Trigger	SN74LVC2G14	NC7WZ14	NL27WZ14	NLU2G14	NLX2G14	—	74LVC2G14	—	—
2G17	Dual Buffer w/Schmitt Trigger Input	SN74LVC2G17	NC7WZ17	NL27WZ17	NLU2G17	NLX2G17	—	74LVC2G17	—	—
2G32	Dual 2-Input OR	SN74LVC2G32	NCWZ32	NL27WZ32	—	—	TC7WZ32	74LVC2G32	—	—
2G34	Dual Buffer Gate	SN74LVC2G34	NC7WZ16	NL27WZ16	—	—	—	74LVC2G34	—	—
2G38	Dual 2-Input NAND w/Open Drain Output	SN74LVC2G38	NCWZ38	—	—	—	TC7WZ38	74LVC2G38	—	—
2G74	D-Type Flip-Flop w/Pre and CLR	SN74LVC2G74	NC7SZ74	NL17SZ74	—	—	TC7WZ74	74LVC2G74	—	—
2G79	Dual D-Type Flip-Flop	SN74LVC2G79	—	—	—	—	—	—	—	—
2G80	Dual D-Type Flip-Flop	SN74LVC2G80	—	—	—	—	—	—	—	—
2G86	Dual 2-Input Exclusive-OR	SN74LVC2G86	NC7WZ86	NL27WZ86	—	NLX2G86	—	74LVC2G86	—	—
2G125	Dual-Bus Buffer Gate w/3-State	SN74LVC2G125	NC7WZ125	NL27WZ125	—	—	—	74LVC2G125	—	—
2G126	Dual-Bus Buffer Gate w/3-State	SN74LVC2G126	NC7WZ126	NL27WZ126	—	—	—	74LVC2G126	—	—
2G132	Dual 2-Input NAND w/Schmitt Trigger Input	SN74LVC2G132	NC7WZ132	—	—	—	—	—	—	—
2G157	2-Input Non-Inverting Mux	SN74LVC2G157	—	—	—	—	—	—	—	—
2G240	Dual-Bus Buffer Gate w/3-State	SN74LVC2G240	NC7WZ240	—	—	—	—	74LVC2G240	—	—
2G241	Dual-Bus Buffer Gate w/3-State	SN74LVC2G241	NC7WZ241	—	—	—	—	74LVC2G241	—	—
Triple Gate										
3G04	Triple Inverter	SN74LVC3G04	NC7NZ04	NNL37WZ04	—	—	TC7WZ04	74LVC3G04	—	—
3GU04	Triple Inverter (Unbuffered)	SN74LVC3GU04	NC7NZU04	—	—	—	TC7WZU04	74LVC3GU04	—	—
3G06	Triple Inverter Buffer/Driver w/Open Drain Output	SN74LVC3G06	—	NL37WZ06	—	—	—	74LVC3G06	—	—
3G07	Triple Buffer/Driver w/Open Drain Output	SN74LVC3G07	—	NL37WZ07	—	—	—	74LVC3G07	—	—
3G14	Triple Inverter w/Schmitt Trigger	SN74LVC3G14	NC7NZ14	NL37WZ14	NLU3G14	NLX3G14	TC7WZ14	74LVC3G14	—	—
3G17	Triple Buffer w/Schmitt Trigger	SN74LVC3G17	NC7NZ17	NL37WZ17	NLU3G17	NLX3G17	—	74LVC3G17	—	—
3G34	Triple Buffer	SN74LVC3G34	NC7NZ34	NL37WZ16	—	—	TC7WZ34	74LVC3G34	PI74STX2G08	—

NOTE: Visit www.ti.com/littlelogic for product release updates.

Cross-Reference

Competitor Cross-Reference

AUC Devices

Function	Description	TI (AUC)	Fairchild (NC7SV)	ON (SV)	Toshiba	Pericom
Single Gate (5-pin, unless noted)						
1G00	Single 2-Input NAND	SN74AUC1G00	NL17SV00	—	TC7SA00	—
1G02	Single 2-Input NOR	SN74AUC1G02	NL17SV02	—	—	—
1G04	Single Inverter	SN74AUC1G04	NL17SV04	—	TC7SA04	—
1GU04	Single Inverter (Unbuffered)	SN74AUC1GU04	—	—	TC7SAU04	—
1G06	Single Inverter Buffer/Driver w/Open Drain	SN74AUC1G06	—	—	—	—
1G07	Single Buffer/Driver w/Open Drain Output	SN74AUC1G07	NL17SV08	NL27WZ00	—	—
1G08	Single 2-Input AND	SN74AUC1G08	—	NL27WZ02	TC7SA08	PI74ST1G08
1G14	Single Inverter w/Schmitt Trigger	SN74AUC1G14	—	NL27WZ04	—	—
1G17	Single Buffer w/Schmitt Trigger	SN74AUC1G17	—	NL27WZU04	—	—
1G19	1 of 2 Decoder/Demultiplexer	SN74AUC1G19	NL17SV32	NL27WZ06	TC7PA19	—
1G32	Single 2-Input OR	SN74AUC1G32	—	NL27WZ07	TC7SA32	PI74ST1G32
1G74	D-Type Flip-Flop w/Pre and CLR	SN74AUC1G74	—	NL27WZ08	—	—
1G79	Single D-Type Flip-Flop	SN74AUC1G79	—	NL27WZ14	—	—
1G80	Single D-Type Flip-Flop	SN74AUC1G80	—	NL27WZ17	—	—
1G86	Single 2-Input Exclusive-OR	SN74AUC1G86	—	NL27WZ32	—	PI74ST1G86
1G125	Single-Bus Buffer Gate w/3-State	SN74AUC1G125	—	NL27WZ16	—	PI74ST1G125
1G126	Single-Bus Buffer Gate w/3-State	SN74AUC1G126	—	—	—	PI74ST1G126
1G240	Single-Bus Buffer Gate w/3-State	SN74AUC1G240	—	NL17SZ74	—	—
Dual Gate (8-pin, unless noted)						
2G00	Dual 2-Input NAND	SN74LVC3G04	—	—	—	—
2G02	Dual 2-Input NOR	SN74LVC3GU04	—	—	—	—
2G04	Dual Inverter	—	NC7WV04	—	TCPA04	—
2GU04	Dual Inverter (Unbuffered)	SN74LVC3G07	—	—	TCPAU04	—
2G06	Dual Inverter Buffer/Driver w/Open Drain Output	SN74LVC3G14	—	—	—	—
2G07	Dual Buffer/Driver w/Open Drain Output	SN74LVC3G17	NC7WV07	—	—	—
2G08	Dual 2-Input AND	SN74LVC3G34	—	—	—	—
2G32	Dual 2-Input OR	SN74LVC3G04	—	—	—	—
2G34	Dual Buffer	SN74LVC3GU04	NC7WV16	—	TC7PA34	—
2G79	Dual D-Type Flip-Flop	SN74LVC3G06	—	—	—	—
2G80	Dual D-Type Flip-Flop	SN74LVC3G07	—	—	—	—
2G86	Dual 2-Input Exclusive-OR	SN74LVC3G14	—	—	—	—
2G125	Dual-Bus Buffer Gate w/3-State	SN74LVC3G17	NC7WV125	—	—	—
2G126	Dual-Bus Buffer Gate w/3-State	SN74LVC3G34	—	—	—	—
2G240	Dual-Bus Buffer Gate w/3-State	SN74LVC3G17	—	—	—	—
2G241	Dual-Bus Buffer Gate w/3-State	SN74LVC3G34	—	—	—	—

NOTE: Visit www.ti.com/littlelogic for product release updates.

Cross-Reference

Competitor Cross-Reference

Signal-Switch Devices

Function	Description	TI	Toshiba	Fairchild	NXP	Pericom
CBT1G125	Single FET Bus Switch	SN74CBT1G125	—	—	—	—
CBTD1G125	Single FET Bus Switch	SN74CBTD1G125	—	—	—	—
CBT1G384	Single Low-Power Bus Switch	SN74CBT1G384	TC7SB384	NC7SZ384	74LVC1G384	—
CBTD1G384	384 Function w/Level Shifting	SN74CBTD1G384	TC7SBD384	NC7SZD384	—	—
CBTLV1G125	Single LV FET Bus Switch	SN74CBTLV1G125	—	—	—	—
CB3T1G125	Single FET Bus Switch	SN74CB3T1G125	—	—	—	—
AUC1G66						
AUC1G66	Single Analog Switch	SN74AUC1G66	—	—	—	—
AUC2G53	SPDT Analog Switch	SN74AUC2G53	TC7PA53	—	—	—
AUC2G66	Dual Analog Switch	SN74AUC2G66	—	—	—	—
LVC1G66						
LVC1G66	Single Analog Switch	SN74LVC1G66	—	NC7SZ66	74LVC1G66	—
LVC1G3157	SPDT Analog Switch	SN74LVC1G3157	—	NC7SB3157	74LVC1G3157	PISA3157
LVC2G53	SPDT Analog Switch	SN74LVC2G53	—	—	—	—
LVC2G66	Dual Analog Switch	SN74LVC2G66	—	NC7WB66	74LVC2G66	—

AUP Devices (5-pin, unless noted)

Function	Description	TI (AUP)	NXP (AUP)	Fairchild (NC7SV)	Toshiba
Single Gate					
1G00	Single 2-Input NAND	SN74AUP1G00	74AUP1G00	NC7SP00	TC7SG00
1G02	Single 2-Input NOR	SN74AUP1G02	74AUP1G02	NC7SP02	TC7SG02
1G04	Single Inverter	SN74AUP1G04	74AUP1G04	NC7SP04	TC7SG04
1G06	Single Inverter Buffer/Driver w/Open Drain Output	SN74AUP1G06	74AUP1G06	—	—
1G07	Single Buffer/Driver w/Open Drain Output	SN74AUP1G07	74AUP1G07	—	TC7SG07
1G08	Single 2-Input AND	SN74AUP1G08	74AUP1G08	NC7SP08	TC7SG08
1G14	Single Inverter w/Schmitt Trigger	SN74AUP1G14	74AUP1G14	NC7SP14	TC7SG14
1G17	Single Buffer w/Schmitt Trigger	SN74AUP1G17	74AUP1G17	NC7SP17	TC7SG17
1G32	Single 2-Input OR	SN74AUP1G32	74AUP1G32	NC7SP32	TC7SG32
1G34	Single Buffer	SN74AUP1G344	74AUP1G34	NC7SP34	TC7SG34
1G74	Single Positive-Edge-Trigger D-Type Flip-Flop	SN74AUP1G74	74AUP1G74	NC7SP74	—
1G79	Single D-Type Flip-Flop	SN74AUP1G79	74AUP1G79	—	—
1G80	Single D-Type Flip-Flop	SN74AUP1G80	74AUP1G80	—	—
1G125	Single-Bus Buffer Gate w/3-State	SN74AUP1G125	74AUP1G125	NC7SP125	TC7SG125
1G126	Single-Bus Buffer Gate w/3-State	SN74AUP1G126	74AUP1G126	NC7SP126	TC7SG126
1G157	Single 2-Input Non-Inverting MUX	SN74AUP1G157	74AUP1G157	NC7SP157	—
1G240	Single-Bus Buffer Gate w/3-State	SN74AUP1G240	74AUP1G240	—	—
Dual Gate (8-pin, unless noted)					
2G00	Dual 2-Input NAND	SN74AUP2G00	74AUP2G00	NC7WP00	—
2G02	Dual 2-Input NOR	SN74AUP2G02	74AUP2G02	NC7WP02	—
2G04	Dual Inverter	SN74AUP2G04	74AUP2G04	NC7WP04	—
2G06	Dual Inverter Buffer/Driver w/Open Drain Output	SN74AUP2G06	74AUP2G06	—	—
2G07	Dual Buffer/Driver w/Open Drain Output	SN74AUP2G07	74AUP2G07	NC7WP07	—
2G08	Dual 2-Input AND	SN74AUP2G08	74AUP2G08	NC7WP08	—
2G125	Dual-Bus Buffer Gate w/3-State	SN74AUP2G125	74AUP2G125	NC7WP125	—
2G126	Dual-Bus Buffer Gate w/3-State	SN74AUP2G126	74AUP2G126	NC7WP126	—
2G14	Dual Inverter w/Schmitt Trigger	SN74AUP2G14	74AUP2G14	NC7WP14	—
2G17	Dual Buffer w/Schmitt Trigger Input	SN74AUP2G17	74AUP2G17	NC7WV17	—
2G240	Dual-Bus Buffer Gate w/3-State	SN74AUP2G240	74AUP2G240	NC7WP240	—
2G241	Dual-Bus Buffer Gate w/3-State	SN74AUP2G241	74AUP2G241	—	—

NOTE: Visit www.ti.com/littlelogic for product release updates.

Cross-Reference

Competitor Cross-Reference

AUP Devices (5-pin, unless noted) (continued)

Function	Description	TI (AUP)	NXP (AUP)	Fairchild (NC7SV)	Toshiba
2G32	Dual 2-Input OR	SN74AUP2G32	74AUP2G32	NC7WP32	—
2G34	Dual Buffer Gate	SN74AUP2G34	74AUP2G34	—	—
2G79	Dual D-Type Flip-Flop	SN74AUP2G79	74AUP2G79	—	—
2G80	Dual D-Type Flip-Flop	SN74AUP2G80	74AUP2G80	—	—
Triple gates					
3G04	Triple Inverter	SN74AUP3G04	74AUP3G04	NC7NP04	—
3G06	Triple Inverter Buffer/Driver w/Open Drain Output	SN74AUP3G06	74AUP3G06	—	—
3G07	Triple Buffer/Driver w/Open Drain Output	SN74AUP3G07	74AUP3G07	—	—
3G17	Triple Buffer w/Schmitt Trigger	SN74AUP3G17	74AUP3G17	—	—
3G34	Triple Buffer	SN74AUP3G34	74AUP3G34	NC7NP34	—

AHC Devices

Function	Description	TI (AHC)	Toshiba (TC7S/W)	Fairchild (NC7S)	ON (VHC)	STMicro (V1G)	NXP
1G00	Single 2-Input NAND Gate	SN74AHC1G00	TC7SH00	NC7S00	MC74VHC1G00	74V1G00	74AHC1G00
1G02	Single 2-Input NOR	SN74AHC1G02	TC7SH02	NC7S02	MC74VHC1G02	74V1G02	74AHC1G02
1G04	Single Inverter	SN74AHC1G04	TC7SH04	NC7S04	MC74VHC1G04	74V1G04	74AHC1G04
1GU04	Single Inverter (Unbuffered)	SN74AHC1GU04	TC7SHU04	NC7SU04	MC74VHC1GU04	74V1GU04	74AHC1GU04
1G08	Single 2-Input AND	SN74AHC1G08	TC7SH08	NC7S08	MC74VHC1G08	74V1G08	74AHC1G08
1G14	Single Inverter w/Schmitt Trigger	SN74AHC1G14	TC7SH14	NC7S14	MC74VHC1G14	74V1G14	74AHC1G14
1G32	Single 2-Input OR 2	SN74AHC1G32	TC7SH32	NC7S32	MC74VHC1G32	74V1G32	74AHC1G32
1G86	Single 2-Input Exclusive-OR	SN74AHC1G86	TC7SH86	NC7S86	MC74VHC1G86	74V1G86	74AHC1G86
1G125	Single-Bus Buffer Gate w/3-State	SN74AHC1G125	TC7SH125	—	MC74VHC1G125	74V1G125	74AHC1G125
1G126	Single-Bus Buffer Gate w/3-State	SN74AHC1G126	TC7SH126	—	MC74VHC1G126	74V1G126	74AHC1G126

AHCT Devices

Function	Description	TI (AHCT)	Toshiba (TC7SE/WT)	Fairchild (NC7ST)	ON (VHC1GT)	STMicro (V1T)	NXP
1G00	Single 2-Input NAND	SN74AHCT1G00	TC7SET00	NC7S00	MC74VHC1G00	74V1G00	74AHC1G00
1G02	Single 2-Input NOR	SN74AHCT1G02	TC7SET02	NC7S02	MC74VHC1G02	74V1G02	74AHC1G02
1G04	Single Inverter	SN74AHCT1G04	TC7SET044	NC7S04	MC74VHC1G04	74V1G04	74AHC1G04
1G08	Single 2-Input AND	SN74AHCT1G08	TC7SET08	NC7SU04	MC74VHC1GU04	74V1GU04	74AHC1GU04
1G14	Single Inverter w/Schmitt Trigger	SN74AHCT1G14	—	NC7S08	MC74VHC1G08	74V1G08	74AHC1G08
1G32	Single 2-Input OR	SN74AHCT1G32	TC7SET32	NC7S14	MC74VHC1G14	74V1G14	74AHC1G14
1G86	Single 2-Input Exclusive-OR	SN74AHCT1G86	TC7SET86	NC7S32	MC74VHC1G32	74V1G32	74AHC1G32
1G125	Single-Bus Buffer Gate w/3-State	SN74AHCT1G125	—	NC7S86	MC74VHC1G86	74V1G86	74AHC1G86
1G126	Single-Bus Buffer Gate w/3-State	SN74AHCT1G126	—	—	MC74VHC1G125	74V1G125	74AHC1G125

NOTE: Visit www.ti.com/littlelogic for product release updates.

Cross-Reference

Competitor Cross-Reference

Configurable Devices

Function	Description	TI	Fairchild	NXP
LVC1G57	Single Configurable (5 functions)	SN74LVC1G57	NC7SZ57	74LVC1G57
LVC1G58	Single Configurable (5 functions)	SN74LVC1G58	NC7SZ58	74LVC1G58
LVC1G97	Single Configurable (9 functions)	SN74LVC1G97	—	74LVC1G97
LVC1G98	Single Configurable (9 functions)	SN74LVC1G98	—	74LVC1G98
LVC1G99	Ultra-Configurable (60 functions)	SN74LVC1G99	—	—
AUP1G57	Single Configurable (5 functions)	SN74AUP1G57	NC7SP57/74AUP1G57	74AUP1G57
AUP1G58	Single Configurable (5 functions)	SN74AUP1G58	NC7SP58/74AUP1G58	74AUP1G58
AUP1G97	Single Configurable (9 functions)	SN74AUP1G97	74AUP1G97	74AUP1G97
AUP1G98	Single Configurable (9 functions)	SN74AUP1G98	74AUP1G98	74AUP1G98
AUP1G99	Ultra-Configurable (60 functions)	SN74AUP1G99	—	—

NOTE: Visit www.ti.com/littlelogic for product release updates.

AUP1T Translators

Function	Description	TI	ON	NXP	Fairchild
AUP1T00	Single 2-Input Positive-NAND Gate	SN74AUP1T00	MC74VHC1GT00	—	—
AUP1T02	Single 2-Input Positive-NOR Gate	SN74AUP1T02	MC74VHC1GT00	—	—
AUP1T04	Single Inverter Gate	SN74AUP1T04	MC74VHC1GT04	—	—
4AUP1T08	2-Input Positive-AND Gate	SN74AUP1T08	MC74VHC1GT08	—	—
AUP1T14	Single Schmitt-Trigger Inverter Gate	SN74AUP1T14	MC74VHC1GT14	—	—
AUP1T157	Buffer Multiplexer (Noninverted)	SN74AUP1T157	—	—	—
AUP1T158	Buffer Multiplexer (Inverted)	SN74AUP1T158	—	—	—
AUP1T17	Single Schmitt-Trigger Buffer Gate	SN74AUP1T17	MC74VHC1GT86	—	—
AUP1T32	2-Input Positive-OR Gate	SN74AUP1T32	MC74VHC1GT32	—	—
AUP1T57	Configurable, Single-Supply Voltage Translator	SN74AUP1T57	—	74AUP1T57	—
AUP1T58	Configurable, Single-Supply Voltage Translator	SN74AUP1T58	—	74AUP1T58	—
AUP1T86	2-Input Exclusive-OR Gate	SN74AUP1T86	MC74VHC1GT86	—	—
AUP1T87	2-Input Positive Exclusive-NOR Gate	SN74AUP1T87	—	—	—
AUP1T97	Configurable, Single-Supply Voltage Translator	SN74AUP1T97	—	74AUP1T97	—
AUP1T98	Configurable, Single-Supply Voltage Translator	SN74AUP1T98	—	74AUP1T98	—

NOTE: Visit www.ti.com/littlelogic for product release updates.

Cross-Reference

Part Number Definition

Naming System

SN74AUP 1G 08 DRY R

R=Tape & Reel
T= Small Tape & Reel

Logic Gate Function

1G	Single Gate
2G	Dual Gate
3G	Triple Gate
1T	Single Gate Translation
2T	Dual Gate Translation

AHC	CMOS/CMOS
AHCT	TTL to 5 V CMOS
LVC	Low-Voltage CMOS
AUP	Low Power Consumption
AUC	Ultra-Low-Voltage 1.8 V
CBT	5 V Digital Switch
CBTD	5 V to 3.3 V Translation Switch
CBTLV	Low-Voltage Digital Switch

DBV	5/6 Leads SOT-23
DCK	5/6 Leads SC-70
DRL	5/6 Leads SOT553/563
YZP	5/6/8 NanoFree™
YFP	5/6/8 NanoFree™
YZV	4 Leads DSBGA
DRY	5/6 QFN
RSE	5/6 QFN
DCT	8 Leads SM8
DCU	8 Leads US8
DSF	5/6 Leads μQFN
DQE	8 Leads μQFN
DPW	5 Leads μQFN

Competitor Part Prefixes

Signal-Switch Devices

TI	TOSHIBA	FAIRCHILD	ON	ON (NLU)	ON (NLX)	STMicro	NXP	Pericom
Little Logic								
SN74AHC1G	TC7SH	NC7S	MC74VHC1G	—	—	74V1G	74AHC1G	—
SN74AHCT1G	TC7SET	NC7ST	MC74VHC1GT	—	—	74V1GT	74AHCT1G	—
SN74AUC1G	TC7SA/PA	NC7SV	NL17SV	—	—	—	—	—
SN74AUC2G	TC7PA	NC7WW	—	—	—	—	—	—
SN74AUP1G	TC7SG	NC7SP	—	—	—	—	74AUP1G	—
SN74LVC1G	TC7SZ	NC7SZ	NL17SZ	NLU1G	NLX1G	74LX1G	74LVC1G	PI74STX1G
SN74LVC2G	TC7WZ	NC7WZ	NL27WZ	NLU1G	NLX1G	—	74LVC2G	PI74STX2G
SN74LVC3G	TC7WZ	NC7NZ	NL37WZ	NLU1G	NLX1G	—	74LVC3G	—
Little Logic Signal Switches								
SN74AUC2G	TC7PA	—	—	—	—	—	—	—
SN74CBT1G	TC7SB	NC7SZ	—	—	—	—	—	—
SN74CBTD1G	TC7SBD	NC7SZD	—	—	—	—	—	—
SN74CBTLV1G	TC7SBL	—	—	—	—	—	—	—
SN74LVC1G	—	NC7SZ	—	—	—	—	74LVC1G	—
SN74LVC2G	—	NC7WB	—	—	—	—	—	—
Little Logic Configurables								
SN74AUP1G	—	NC7SP	—	—	—	—	—	—
SN74LVC1G	—	NC7SZ	—	—	—	—	—	—
Little Logic Translation								
SN74LVC1T	—	NC7SP	—	—	—	—	—	—
SN74LVC2T	—	NC7SZ	—	—	—	—	—	—

NOTE: Visit www.ti.com/littlelogic for product release updates.

Jump start your design process

- Comprehensive reference designs
- Complete schematics/block diagrams
- BOMs
- Design files and test reports

- ▶ Search by product type, application or keyword to find inspiration for your next design
www.ti.com/tidesigns



TI E2E Community

engineer.to.engineer,
solving problems

e2e.ti.com

TI Worldwide Technical Support

Internet

TI Semiconductor Product Information Center Home Page

support.ti.com

TI E2E™ Community Home Page

e2e.ti.com

Product Information Centers

Americas Phone +1(512) 434-1560
Brazil Phone 0800-891-2616
Mexico Phone 0800-670-7544
Fax +1(972)927-6377
Internet support.ti.com/sc/pic/americas.htm

Europe, Middle East, and Africa

Phone
European Free Call 00800-ASK-TEXAS
(00800 275 83927)
International +49 (0) 8161 80 2121
Russian Support +7 (4) 95 98 10 701

Note: The European Free Call (Toll Free) number is not active in all countries. If you have technical difficulty calling the free call number, please use the international number above.

Fax +49 (0) 8161 80 2045
Internet www.ti.com/asktexas
Direct Email asktexas@ti.com

Japan

Fax International +81-3-3344-5317
Domestic 0120-81-0036

Internet

International support.ti.com/sc/pic/japan.htm
Domestic www.tij.co.jp/pic

Asia

Phone Toll-Free Number
Note: Toll-free numbers may not support mobile and IP phones.
Australia 1-800-999-084
China 800-820-8682
Hong Kong 800-96-5941
India 000-800-100-8888
Indonesia 001-803-8861-1006
Korea 080-551-2804
Malaysia 1-800-80-3973
New Zealand 0800-446-934
Philippines 1-800-765-7404
Singapore 800-886-1028
Taiwan 0800-006800
Thailand 001-800-886-0010
International +86-21-23073444
Fax +86-21-23073686
Email tiasia@ti.com or ti-china@ti.com
Internet support.ti.com/sc/pic/asia.htm

Important Notice: The products and services of Texas Instruments Incorporated and its subsidiaries described herein are sold subject to TI's standard terms and conditions of sale. Customers are advised to obtain the most current and complete information about TI products and services before placing orders. TI assumes no liability for applications assistance, customer's applications or product designs, software performance, or infringement of patents. The publication of information regarding any other company's products or services does not constitute TI's approval, warranty or endorsement thereof.

The platform bar and E2E are trademarks of Texas Instruments. All other trademarks are the property of their respective owners.

IMPORTANT NOTICE FOR TI DESIGN INFORMATION AND RESOURCES

Texas Instruments Incorporated ("TI") technical, application or other design advice, services or information, including, but not limited to, reference designs and materials relating to evaluation modules, (collectively, "TI Resources") are intended to assist designers who are developing applications that incorporate TI products; by downloading, accessing or using any particular TI Resource in any way, you (individually or, if you are acting on behalf of a company, your company) agree to use it solely for this purpose and subject to the terms of this Notice.

TI's provision of TI Resources does not expand or otherwise alter TI's applicable published warranties or warranty disclaimers for TI products, and no additional obligations or liabilities arise from TI providing such TI Resources. TI reserves the right to make corrections, enhancements, improvements and other changes to its TI Resources.

You understand and agree that you remain responsible for using your independent analysis, evaluation and judgment in designing your applications and that you have full and exclusive responsibility to assure the safety of your applications and compliance of your applications (and of all TI products used in or for your applications) with all applicable regulations, laws and other applicable requirements. You represent that, with respect to your applications, you have all the necessary expertise to create and implement safeguards that (1) anticipate dangerous consequences of failures, (2) monitor failures and their consequences, and (3) lessen the likelihood of failures that might cause harm and take appropriate actions. You agree that prior to using or distributing any applications that include TI products, you will thoroughly test such applications and the functionality of such TI products as used in such applications. TI has not conducted any testing other than that specifically described in the published documentation for a particular TI Resource.

You are authorized to use, copy and modify any individual TI Resource only in connection with the development of applications that include the TI product(s) identified in such TI Resource. NO OTHER LICENSE, EXPRESS OR IMPLIED, BY ESTOPPEL OR OTHERWISE TO ANY OTHER TI INTELLECTUAL PROPERTY RIGHT, AND NO LICENSE TO ANY TECHNOLOGY OR INTELLECTUAL PROPERTY RIGHT OF TI OR ANY THIRD PARTY IS GRANTED HEREIN, including but not limited to any patent right, copyright, mask work right, or other intellectual property right relating to any combination, machine, or process in which TI products or services are used. Information regarding or referencing third-party products or services does not constitute a license to use such products or services, or a warranty or endorsement thereof. Use of TI Resources may require a license from a third party under the patents or other intellectual property of the third party, or a license from TI under the patents or other intellectual property of TI.

TI RESOURCES ARE PROVIDED "AS IS" AND WITH ALL FAULTS. TI DISCLAIMS ALL OTHER WARRANTIES OR REPRESENTATIONS, EXPRESS OR IMPLIED, REGARDING TI RESOURCES OR USE THEREOF, INCLUDING BUT NOT LIMITED TO ACCURACY OR COMPLETENESS, TITLE, ANY EPIDEMIC FAILURE WARRANTY AND ANY IMPLIED WARRANTIES OF MERCHANTABILITY, FITNESS FOR A PARTICULAR PURPOSE, AND NON-INFRINGEMENT OF ANY THIRD PARTY INTELLECTUAL PROPERTY RIGHTS.

TI SHALL NOT BE LIABLE FOR AND SHALL NOT DEFEND OR INDEMNIFY YOU AGAINST ANY CLAIM, INCLUDING BUT NOT LIMITED TO ANY INFRINGEMENT CLAIM THAT RELATES TO OR IS BASED ON ANY COMBINATION OF PRODUCTS EVEN IF DESCRIBED IN TI RESOURCES OR OTHERWISE. IN NO EVENT SHALL TI BE LIABLE FOR ANY ACTUAL, DIRECT, SPECIAL, COLLATERAL, INDIRECT, PUNITIVE, INCIDENTAL, CONSEQUENTIAL OR EXEMPLARY DAMAGES IN CONNECTION WITH OR ARISING OUT OF TI RESOURCES OR USE THEREOF, AND REGARDLESS OF WHETHER TI HAS BEEN ADVISED OF THE POSSIBILITY OF SUCH DAMAGES.

You agree to fully indemnify TI and its representatives against any damages, costs, losses, and/or liabilities arising out of your non-compliance with the terms and provisions of this Notice.

This Notice applies to TI Resources. Additional terms apply to the use and purchase of certain types of materials, TI products and services. These include; without limitation, TI's standard terms for semiconductor products (<http://www.ti.com/sc/docs/stdterms.htm>), [evaluation modules](#), and [samples](http://www.ti.com/sc/docs/sampterm.htm) (<http://www.ti.com/sc/docs/sampterm.htm>).

Mailing Address: Texas Instruments, Post Office Box 655303, Dallas, Texas 75265
Copyright © 2018, Texas Instruments Incorporated