

RECOMMENDED
CABLE STRIPPING DIM'S

REV.	DATE	ECR NO.	DESCRIPTION
NC	09/16/03	XXXXXX	INITIAL RELEASE
A	10/16/07	XXXXXX	REVISE BODY DIA. (7.8MM) AND FERRULE LENGTH (9.5MM) REVISE CABLE STRIPPING - ADD FOIL REMOVAL
B	07/20/08	XXXXXX	REVISE OVERALL BODY LENGTH TO 18.80MM
C	04/15/10	XXXXXX	THE DESIGN WAS CHANGED

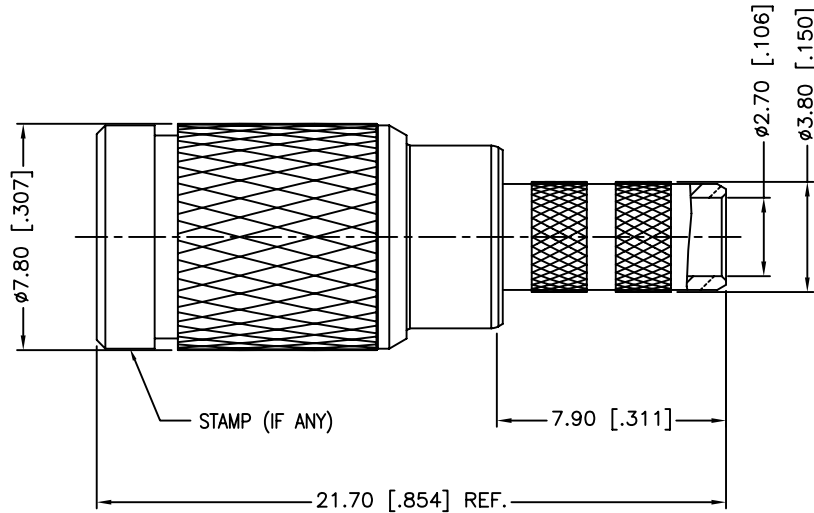

STAMP (IF ANY)

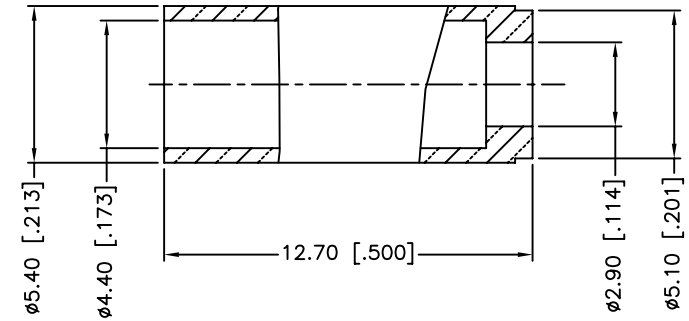
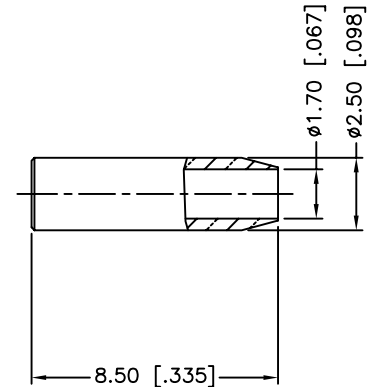
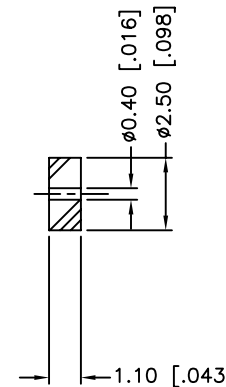
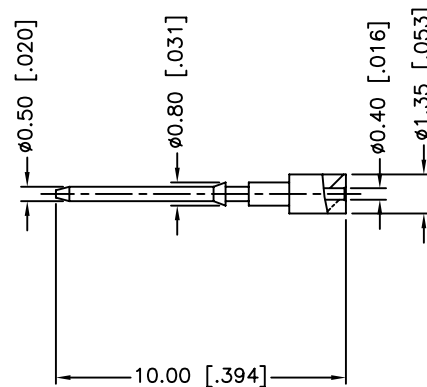

1. FREQUENCY RANGE: DC - 3 GHz
2. VSWR (RETURN LOSS): 1.15, MAX.
3. CRIMPED FERRULE
HEX CRIMP SIZE .178"
4. CRIMPED CONTACT PIN
HEX CRIMP SIZE .043"

10	FERRULE	BRASS	NICKEL	1
9	SPACER	BRASS	NICKEL	1
8	SLEEVE	PTFE	NATURAL	1
7	CONTACT PIN	BRASS	GOLD	1
6	BARREL	BRASS	NICKEL	1
5	INSULATOR	PTFE	NATURAL	1
4	OUT CONTACT	BER. COPPER	GOLD	1
3	BODY	BRASS	NICKEL	1
2	SPRING	BER. COPPER	NATURAL	1
1	SHELL	BRASS	NICKEL	1
	DESCRIPTION	MATERIAL	FINISH	QTY

UNLESS OTHERWISE SPECIFIED DIMENSIONS ARE IN MILLIMETERS. DIMENSIONS IN [] ARE IN INCHES AND FOR CUSTOMER REFERENCE ONLY.

UNLESS OTHERWISE SPECIFIED TOLERANCES FOR MILLIMETERS ARE:
0.5 - 8mm ± 0.20mm
8 - 30mm ± 0.40mm
30 - 120mm ± 0.50mm

UNLESS OTHERWISE SPECIFIED TOLERANCES FOR INCHES ARE:
.020 - .315 = ± 0.007"
.315 - 1.180 = ± 0.015"
1.180 - 4.724 = ± 0.020"

DO NOT SCALE DRAWING

APPROVALS		DATE
DRAWN	M.ZHANG	04/15/10
CHECKED		
ISSUED		
SHEET	1 OF 1	
CAD FILE	C:/CONNEX/282103-75.DWG	

Amphenol Connex

PART DESCRIPTION			
1.0/2.3 PUSH-PULL CRIMP PLUG (FOR BELDEN 179DT CABLE)			
PART NO.			
282103-75			
DWG. NO.	282103-75.DWG	REV.	C
SIZE	A	SCALE	NA