

4

3

2

1

THIS DRAWING IS UNPUBLISHED. RELEASED FOR PUBLICATION  
© COPYRIGHT ALL RIGHTS RESERVED.

LOC	DIST	REVISIONS			
P	LTR	DESCRIPTION	DATE	DWN	APVD
	B1	ECR-16-009824	28JUL2016	GK	SD

# REPLACED BY OCEAN STYLE APPLICATOR PART NUMBER 2836284-1

FOR REPLACEMENT PARTS FOR APPLICATOR 466441-4  
REFER TO ADDITIONAL PAGE(S). SPARE PARTS KIT (IF LISTED)  
WILL REMAIN AVAILABLE.

THE REPLACEMENT OCEAN STYLE APPLICATOR HAS THE  
SAME TERMINATOR/PRESS INTERFACE AS APPLICATOR  
466441-4

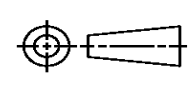
THIS DRAWING IS A CONTROLLED DOCUMENT.		DWN	GOPALAKRISHNA HV			
DIMENSIONS:		CHK	GOPALAKRISHNA HV			
		TOLERANCES UNLESS OTHERWISE SPECIFIED:		APVD		
		0 PLC ± 1 PLC ± 2 PLC ± 3 PLC ± 4 PLC ± ANGLES ±		STOUGH DALE		
MATERIAL		PRODUCT SPEC		NAME		
FINISH		APPLICATION SPEC		MINIATURE QUICK CHANGE APPLICATOR SIDE FEED( FASTON TAB)		
		WEIGHT	SIZE	CAGE CODE	DRAWING NO	RESTRICTED TO
			A3		©- 466441-4	
CUSTOMER DRAWING			SCALE	SHEET 1 OF 2	REV B1	



THIS IS A CONTROLLED DOCUMENT.

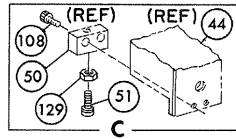
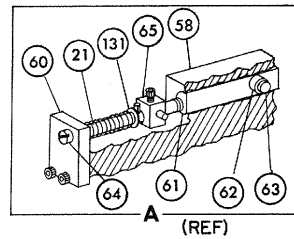

PRE-FEED 1 1/8" STROKE  
POST-FEED 1 5/8" STROKE

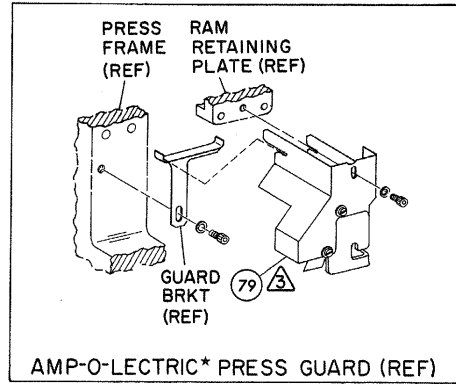
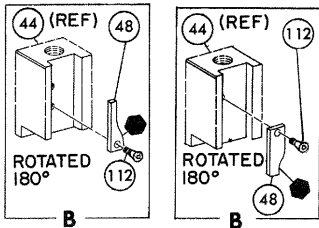

NOTES:  
1- ONLY THE ITEMS WITH QUANTITIES SPECIFIED ON PARTS LIST ARE USED ON THIS APPLICATOR.

▲- USED IN PLACE OF ITEM 38 WHEN INSULATION CRIMP IS NOT USED.

▲- GUARD MUST BE IN PLACE WHEN OPERATING APPLICATOR IN AMP-O-LECTRIC PRESS.

▲- ITEMS WITH QTY. OF REF. SPECIFIED (EXCEPT ITEM 79) ARE USED ON ITEM 46.

KEY:  
■- RECOMMENDED SPARE PARTS CUSTOMER RESPONSIBLE FOR REPLACEMENT.  
▲- LUBRICATE DAILY USING NO. 20 MACHINE OIL.  
●- GREASE LIGHTLY.

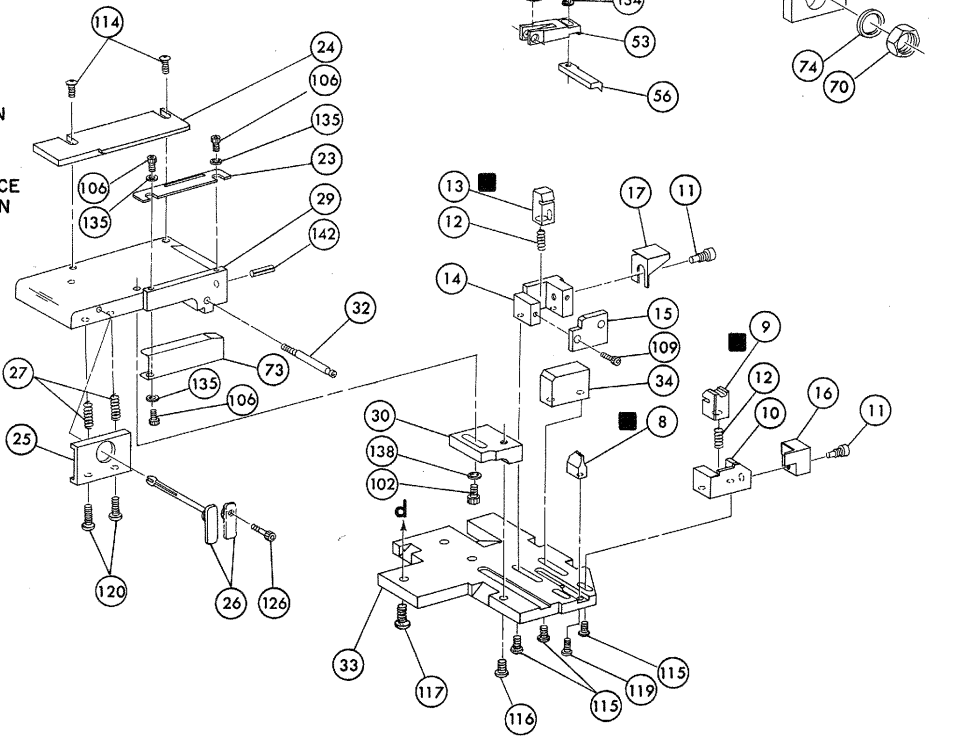

REF.	21045-3	RING, RETAINING 'C' (.187 DIA) FEED FINGER PIN	145	REF.	454220-1	CAP, HOUSING	59
REF.	5-21028-1	PIN, SLOT SPR (.125 DIA X .50) ADJ ROD	143	REF.	454485-1	HOUSING	58
1	4-21028-0	PIN, SLOT SPR (.093 DIA X .75) STR G PLATE	142	1	690542-2	PAWL, FEED	57
REF.	1-21030-1	PIN, DOWEL (.187 DIA X .50) LEVER	141	REF.	240624-1	PIN, FEED FINGER	56
REF.	1-21030-6	PIN, DOWEL (.187 DIA X 1.25) HOUSING	140	REF.	691499-1	SPRING, FEED FINGER	55
1	21024-5	WASHER, LOCK (NO 10) LUB ASSY	139	REF.	690541-1	FINGER, FEED	54
1	21024-5	WASHER, LOCK (NO 10) STRIP GUIDE ADJ BLOCK	138	REF.	455679-1	LEVER, TERMINAL FEED ARM	53
REF.	21024-5	WASHER, LOCK (NO 10) ADJ PLATE	137			BUMPER, HOLDDOWN	52
REF.	21024-5	WASHER, LOCK (NO 10) FEED GUIDE ROD	136			SPACER, TONKER	51
3	21057-2	WASHER, LOCK (NO 4) FRONT STRIP GUIDE	135	1	7-21002-9	BOLT, CRIMPER	50
1	21024-4	WASHER, LOCK (NO 8) FEED FINGER	134	1	690501-4	CAM POST-FEED 1 5/8" STROKE	49
1	21024-4	WASHER, LOCK (NO 8) DEPRESSOR	133				48
1	21024-4	WASHER, LOCK (NO 8) STRIPPER	132	1	459456-1	APPLICATOR, BASIC (SUB ASSY)	46
REF.	21899-4	WASHER, FLAT (5/16 DIA) SCREW ADJ	131	1	690191-1	PLUG, NYLON	45
1	21899-2	WASHER, FLAT (NO 10) LUB ASSY	130	1	455673-1	RAM	44
1	21068-5	NUT, HEX MACH (6-32) HOLDDOWN	129	1	690125-1	WASHER, LAMINATED	43
REF.	21068-5	NUT, HEX MACH (6-32) FEED ADJ	128	1	690124-1	WASHER, RAM	42
			127			DISC, SPACER	41
			126	2	23241-6	BALL, STEEL	40
1	22651-9	SCR, SKT SET (1/4-20 X .25) (LOC-WEL) RAM	125	2	690170-1	SPRING, COMPRESSION	39
			124	1	690142-1	DISC, INSULATION	38
REF.	3-21064-2	SCR, RD HD MACH (6-32 X 1.50) FEED ADJ	123	1	5-690141-1	DISC, WIRE	37
2	2-21002-9	SCR, BUT HD SKT CAP (10-32 X .75) DRAG	122	1	22480-5	WASHER, SPRING	36
1	24073-2	SCR, BUT HD SKT CAP (8-32 X .38) (LOC-WEL) ANVIL	119	REF.	455675-1	POST, RAM	35
REF.	2-21002-9	SCR, BUT HD SKT CAP (10-32 X .75) CAP	118	1	690786-2	SUPPORT, TERMINAL	34
REF.	1-24073-9	SCR, BUT HD SKT CAP (1/4-20 X .75) HOUSING	117			PLATE, BASE	33
REF.	2-21002-7	SCR, BUT HD SKT CAP (10-32 X .50) SG ADJ BLOCK	116	REF.	455689-1	BLOCK, STRIP GUIDE ADJ	30
4	2-21002-2	SCR, BUT HD SKT CAP (8-32 X .50) SHEAR	115	1	455671-2	PLATE, STRIP GUIDE	29
2	2-21002-2	SCR, BUT HD SKT CAP (8-32 X .50) R STRIP GUIDE	114	1	455888-4	SPACER, FRONT SHEAR DEPRESSOR	28
			113	2	1-22284-0	SPRING, DRAG	27
1	1-21002-7	SCR, BUT HD SKT CAP (6-32 X .38) CAM	112	1	690546-1	LEVER, DRAG RELEASE	26
			111	1	240792-1	DRAG, STOCK	25
2	3-23657-8	SCR, SKT HD CAP (6-32 X .25) (LOC-WEL) CP DISC	110	1	690440-6	GUIDE STRIP (REAR)	24
			109	1	690438-1	GUIDE, STRIP (FRONT)	23
			108				22
1	2-22603-0	SCR, HEX HD MACH (8-32 X .31) FEED FINGER	107	REF.	4-22284-9	SPRING, FEED RETURN	21
3	1-21000-3	SCR, SKT HD CAP (4-40 X .25) F STRIP GUIDE	106				20
1	2-21000-7	SCR, SKT HD CAP (8-32 X .50) STRIPPER	105	1	690472-2	STRIPPER	19
REF.	3-21000-7	SCR, SKT HD CAP (10-32 X .75) FEED ROD GUIDE	104			HOLDER, TERMINAL	18
REF.	3-21000-6	SCR, SKT HD CAP (10-32 X .62) FEED ADJ BLOCK	103			GUARD, CHIP (REAR)	17
1	3-21000-4	SCR, SKT HD CAP (10-32 X .38) SG ADJ BLOCK	102	1	691667-1	GUARD, CHIP (FRONT)	16
REF.	3-21000-4	SCR, SKT HD CAP (10-32 X .38) PIVOT BLOCK	101			PLATE, SHEAR (REAR)	15
REF.	455749-1	GUARD, WINDOW	79			HOLDER, SHEAR (REAR)	14
1	1-465184-0	LUBRICATOR ASSY	78			SHEAR, FLOAT (REAR)	13
		OIL, LUBRICATING	77	1	5-22280-0	SPRING, SHEAR	12
2	21017-2	SCR, DRIVE (#2 X .19) ID PLATE	76	1	690461-1	STOP, SHEAR	11
1	461264-1	PLATE, ID	75	1	690459-1	HOLDER, SHEAR (FRONT)	10
REF.	458109-1	WASHER, SPECIAL	74	1	454276-1	SHEAR, FLOAT (FRONT)	9
1	454877-3	PLATE, STRIP GUIDE COVER	73	1	690471-4	ANVIL	8
2	690603-1	SPRING, ASSIST	72			SPACER, DEPRESSOR (REAR)	7
REF.	690517-1	SPACER	71			DEPRESSOR, SHEAR (REAR)	6
		NUT, HEX	70	1	1-455889-4	DEPRESSOR, SHEAR (FRONT)	5
		PLATE, ADJUSTMENT	69	1	233011-4	SPACER, TUBULAR, INS CRIMPER	4
		SHAFT, PIVOT	68	1	683454-1	CRIMPER, INSULATION	3
		BUSHING	67	1	455888-9	SPACER, CRIMPER	2
		LEVER, INTERMEDIATE	66	1	2-456406-0	CRIMPER, WIRE	1
		BLOCK, PIVOT	65				
		SCREW, ADJUSTMENT FEED ROD	64				
		PIN, CAM ROLLER	63				
		ROLLER, CAM	62				
		ROD, FEED	61				
REF.	454178-1	GUIDE, FEED ROD	60				

REMARKS	NO	REV
APPL USED ON MACHINE PART NO	MACH SERIAL NO	DISTRIBUTION
CUSTOMER NAME	APPL SERIAL NO	ORIGINAL
ADDRESS	PURCHASE ORDER	CUSTOMER COPY
CITY	ENG APP	FIELD ENG COPY

CRIMPING DATA					APPLICATOR WILL APPLY	
PAD LTR	CRIMP HEIGHT	WIRE SIZE	WIRE STRIP LENGTH			
A	.062	18				42490-
B	.060	20				63857
C	.057	22				
D	NOT USED					
CRIMP	SIZE	TYPE	FEED	APPL INST		
WIRE	.090	F		A1 8040		
INSUL	.155	O	.440			
WIRE RANGE	22-18	INSULATION RANGE	PRESS NO			
REMARKS	POST-FEED AMPOMATOR					