

WITH MOUNTING CLIPS

8:1

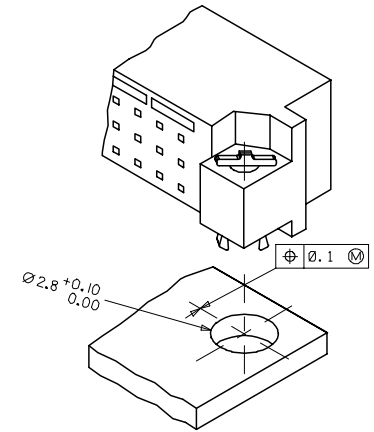
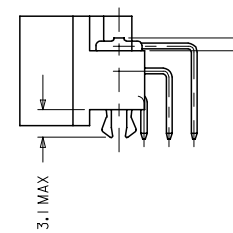

NOTES:

- MATERIALS: THERMOPLASTIC POLYESTER, GLASS FILLED, UL94V-0, COLOUR: PEBBLE GREY RAL 7032
TERMINAL - BRASS
MOUNTING CLIP: STEEL
- FINISH: TERMINAL:-
CONTACT AREA
 - PERFORMANCE LEVEL 1: SELECTIVE GOLD (Au), THICKNESS = 1.1 MICROMETER OVER NICKEL, THICKNESS = 1.25 MICROMETER
 - PERFORMANCE LEVEL 2: SELECTIVE GOLD (Au), THICKNESS = 0.6 MICROMETER OVER NICKEL, THICKNESS = 1.25 MICROMETER
 - PERFORMANCE LEVEL 3: SELECTIVE GOLD (Au), THICKNESS = 0.3 MICROMETER OVER NICKEL, THICKNESS = 1.25 MICROMETER
 TERMINATION AREA:
SELECTIVE TIN, THICKNESS = 2.5 MICROMETER
OVER NICKEL, THICKNESS = 1.25 MICROMETER OVERALL
- MOUNTING CLIP:-
TIN (Sn), THICKNESS = 5-10 MICROMETER,
OVER NICKEL (Ni), THICKNESS = 2.5 MICROMETER
- FOR NON MOUNTING CLIP OPTION, CONNECTOR TO BE SECURED WITH
RIVETS: 2 TUBULAR RIVETS 2.5 x 0.3 ... DIN 7340
SCREWS: 2 CHEESEHEAD SCREWS M2.5 x ... DIN 84 AND 2 HEXAGONAL NUTS M2.5 DIN 934
- MATERIAL NUMBER, BATCH CODE, UL AND CSA MARKING TO BE PRINTED ON THE CONNECTOR
- CUT FACE OF TIP WITHOUT PLATING PERMITTED
- PRODUCT SPECIFICATION : PS-36502-001

RECOMMENDED PCB LAYOUT
COMPONENT SIDE

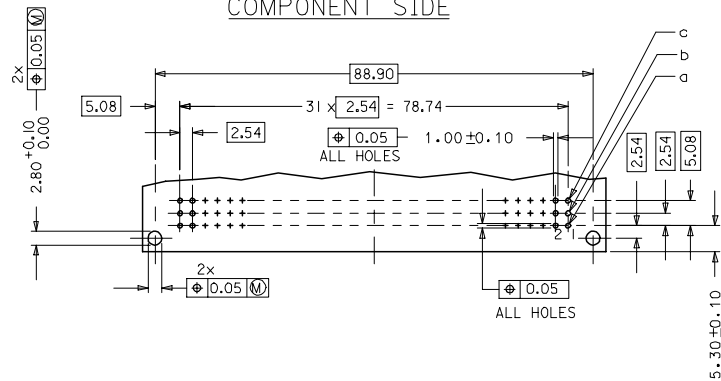

RoHS COMPLIANT

EC No: P2007-0044 DRAWING APPROVED 2006/10/10 CHECKED BY 2006/10/11 APPROVED BY 2006/10/16	QUALITY SYMBOLS ▽=0 ▽=0	GENERAL TOLERANCES (UNLESS SPECIFIED)		DIMENSION STYLE MM ONLY		SCALE 2:1	DESIGN UNITS METRIC	THIRD ANGLE PROJECTION	
		4 PLACES ± 0.15 3 PLACES ± 0.05 2 PLACES ± 0.1 1 PLACE ± 0.15	± --- ± --- ± --- ± ---	INCH ± --- ± --- ± ---	DRAWN BY SS	DATE 1999/09/01	TITLE ASSEMBLY, DIN 41612 C MALE 96 POS	MOLEX INCORPORATED	
C1	DESCRIPTION DRAFT WHERE APPLICABLE MUST REMAIN WITHIN DIMENSIONS	MATERIAL NO. SEE CHART		DOCUMENT NO. SD-36502-001		SHEET NO. 1 OF 2			
		THIS DRAWING CONTAINS INFORMATION THAT IS PROPRIETARY TO MOLEX INCORPORATED AND SHOULD NOT BE USED WITHOUT WRITTEN PERMISSION							

MATERIAL No	MOLEX ENG No	PERF LEVEL	PLATING	CONTACT SEQUENCE/ROW	PREMATING CONTACT POS.	MOUNTING CLIP
36502-0001	MM-B I400-C960	1	Au+Ni	1,2,3....32 a+b+c	NO	NO
36502-0002	MM-B I500-C960	2	Au+Ni	1,2,3....32 a+b+c	NO	NO
36502-0003	MM-B I600-C960	3	Au+Ni	1,2,3....32 a+b+c	NO	NO
36502-0007	MM-B I400-C910	1	Au+Ni	1,2,3....32 a+b+c	NO	YES
36502-0008	MM-B I500-C910	2	Au+Ni	1,2,3....32 a+b+c	NO	YES
36502-0009	MM-B I600-C910	3	Au+Ni	1,2,3....32 a+b+c	NO	YES
36502-0013	MM-B I400-C930	1	Au+Ni	1,2,3....32 a+b+c	1,32a 1,32b 1,32c	NO
36502-0014	MM-B I500-C930	2	Au+Ni	1,2,3....32 a+b+c	1,32a 1,32b 1,32c	NO
36502-0015	MM-B I600-C930	3	Au+Ni	1,2,3....32 a+b+c	1,32a 1,32b 1,32c	NO
36502-0019	MM-B I400-C950	1	Au+Ni	1,2,3....32 a+b+c	1,32a 1,32b 1,32c	YES
36502-0020	MM-B I500-C950	2	Au+Ni	1,2,3....32 a+b+c	1,32a 1,32b 1,32c	YES
36502-0021	MM-B I600-C950	3	Au+Ni	1,2,3....32 a+b+c	1,32a 1,32b 1,32c	YES

DETAILY DETAILX

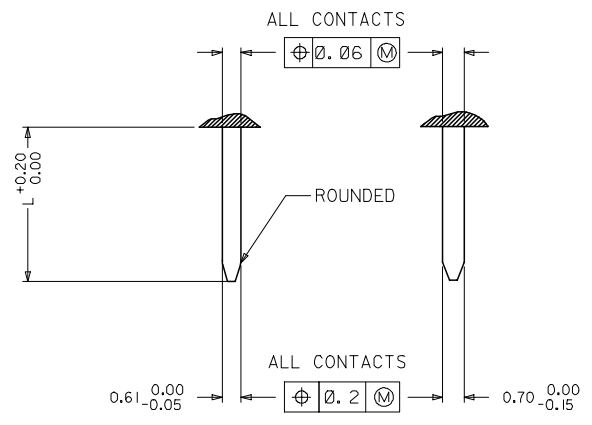

PRE MATING CONTACTS	5.4
NORMAL CONTACTS	4.8
	L

RoHS COMPLIANT

EC No: 2007-0044 DRAWING: 2006/10/10 CHKD: 2006/10/11 APPR: 2006/10/10	QUALITY SYMBOLS ▽=0 ▽=0	GENERAL TOLERANCES (UNLESS SPECIFIED) <table border="1"> <tr> <th></th> <th>mm</th> <th>INCH</th> </tr> <tr> <td>4 PLACES</td> <td>± 0.1</td> <td>± 0.004</td> </tr> <tr> <td>3 PLACES</td> <td>± 0.05</td> <td>± 0.002</td> </tr> <tr> <td>2 PLACES</td> <td>± 0.1</td> <td>± 0.004</td> </tr> <tr> <td>1 PLACE</td> <td>± 0.15</td> <td>± 0.006</td> </tr> </table>		mm	INCH	4 PLACES	± 0.1	± 0.004	3 PLACES	± 0.05	± 0.002	2 PLACES	± 0.1	± 0.004	1 PLACE	± 0.15	± 0.006	DIMENSION STYLE MM ONLY	SCALE 2:1	DESIGN UNITS METRIC	THIRD ANGLE PROJECTION
		mm	INCH																		
4 PLACES	± 0.1	± 0.004																			
3 PLACES	± 0.05	± 0.002																			
2 PLACES	± 0.1	± 0.004																			
1 PLACE	± 0.15	± 0.006																			
DRAWN BY: SS CHECKED BY: GJLOWE APPROVED BY: GJLOWE DATE: 1999/09/01	MATERIAL NO. SEE CHART	DOCUMENT NO. SD-36502-001	SHEET NO. 2 OF 2																		