

ISL62875

PWM DC/DC Controller with VID Inputs for Portable GPU Core-Voltage Regulator

FN6905

Rev 1.00

September 18, 2009

The ISL62875 is a Single-Phase Synchronous-Buck PWM voltage regulator featuring Intersil's Robust Ripple Regulator (R<sup>3</sup>) Technology™. The wide 3.3V to 25V input voltage range is ideal for systems that run on battery or AC-adaptor power sources. The ISL62875 is a low-cost solution for applications requiring dynamically selected slew-rate controlled output voltages. The soft-start and dynamic setpoint slew-rates are capacitor programmed. Voltage identification logic-inputs select four resistor-programmed setpoint reference voltages that directly set the output voltage of the converter between 0.5V to 1.5V, and up to 3.3V using a feedback voltage divider. Robust integrated MOSFET drivers and Schottky bootstrap diode reduce the implementation area and component cost.

Intersil's R<sup>3</sup> Technology™ combines the best features of both fixed-frequency and hysteretic PWM control. The PWM frequency is 500kHz during static operation, becoming variable during changes in load, setpoint voltage, and input voltage when changing between battery and AC-adaptor power. The modulators ability to change the PWM switching frequency during these events in conjunction with external loop compensation produces superior transient response. For maximum efficiency, the converter automatically enters diode-emulation mode (DEM) during light-load conditions such as system standby.

Features

- Input Voltage Range: 3.3V to 25V
- Output Voltage Range: 0.5V to 3.3V
- Output Load up to 30A
- Extremely Flexible Output Voltage Programmability
  - 2-Bit VID Selects Four Independent Setpoint Voltages
  - Simple Resistor Programming of Setpoint Voltages
  - Accepts External Setpoint Reference such as DAC
- ±0.75% System Accuracy: -10°C to +100°C
- Fixed 500kHz PWM Frequency in Continuous Conduction
- Integrated High-current MOSFET Drivers and Schottky Boot-Strap Diode for Optimal Efficiency

Applications\* (see page 21)

- Mobile PC GPU Core Power
- Mobile PC I/O Controller Hub (ICH) VCC Rail
- Tablet PCs/Slates and Netbooks
- Hand-Held Portable Instruments

Related Literature\* (see page 21)

- TB389 "PCB Land Pattern Design and Surface Mount Guidelines for QFN Packages"

Typical Application

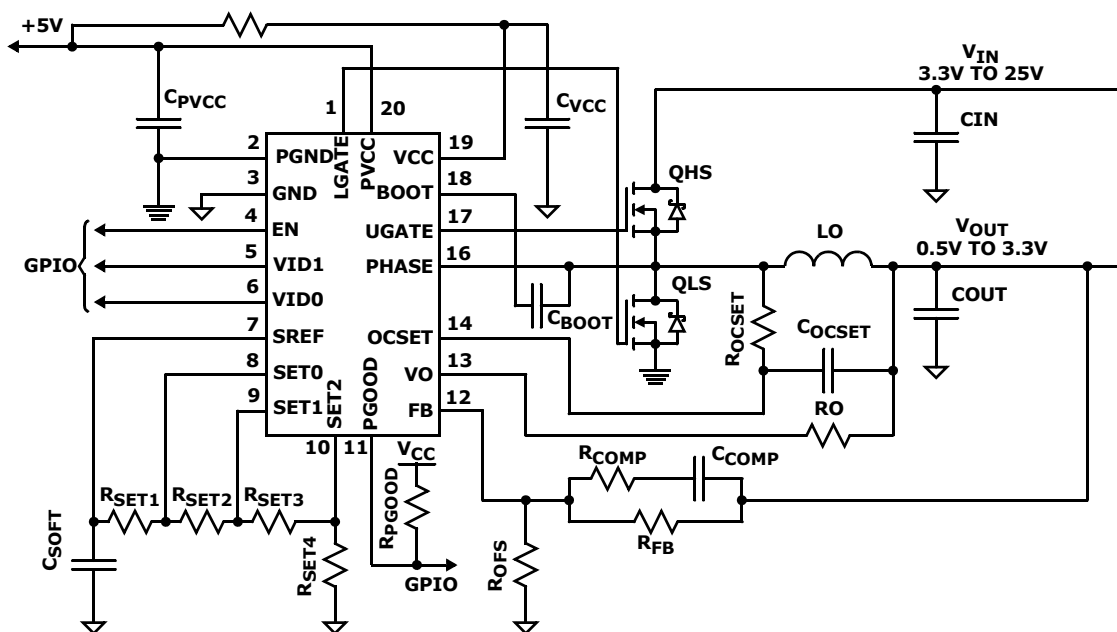

# Application Schematics

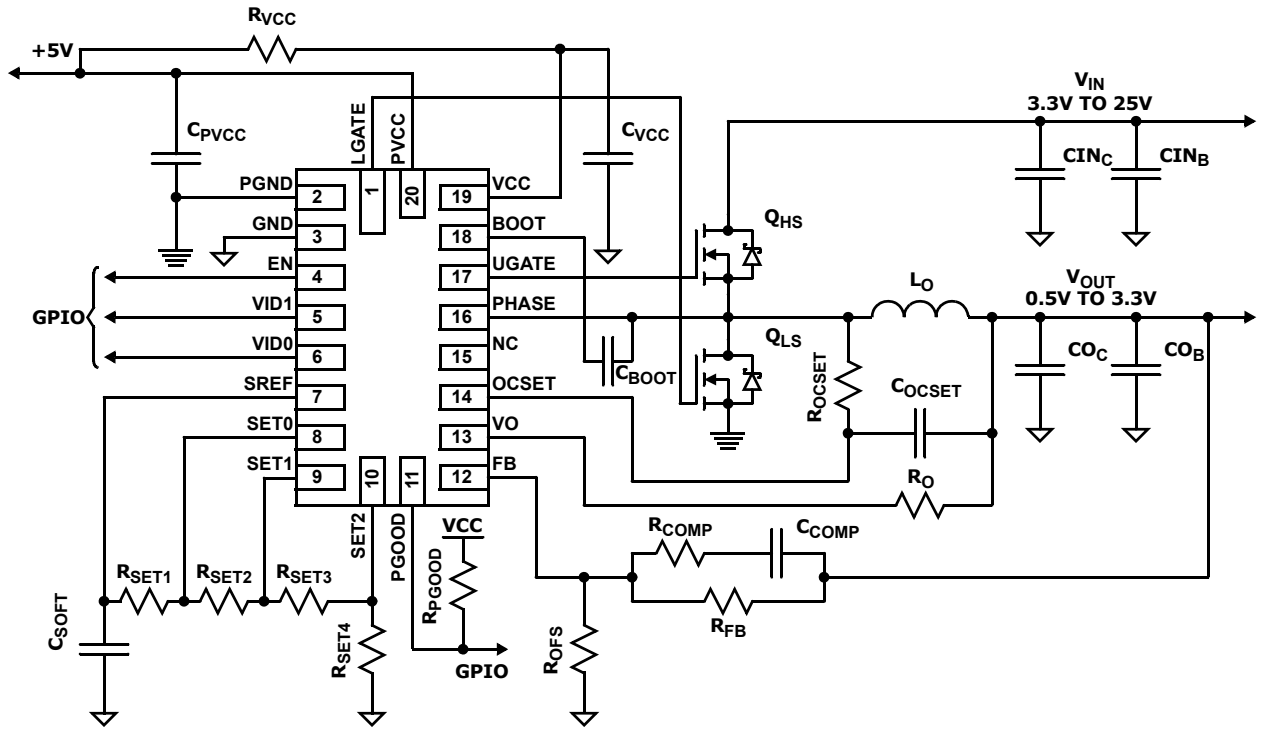

FIGURE 1. ISL62875 APPLICATION SCHEMATIC WITH FOUR OUTPUT VOLTAGE SETPOINTS AND DCR CURRENT SENSE

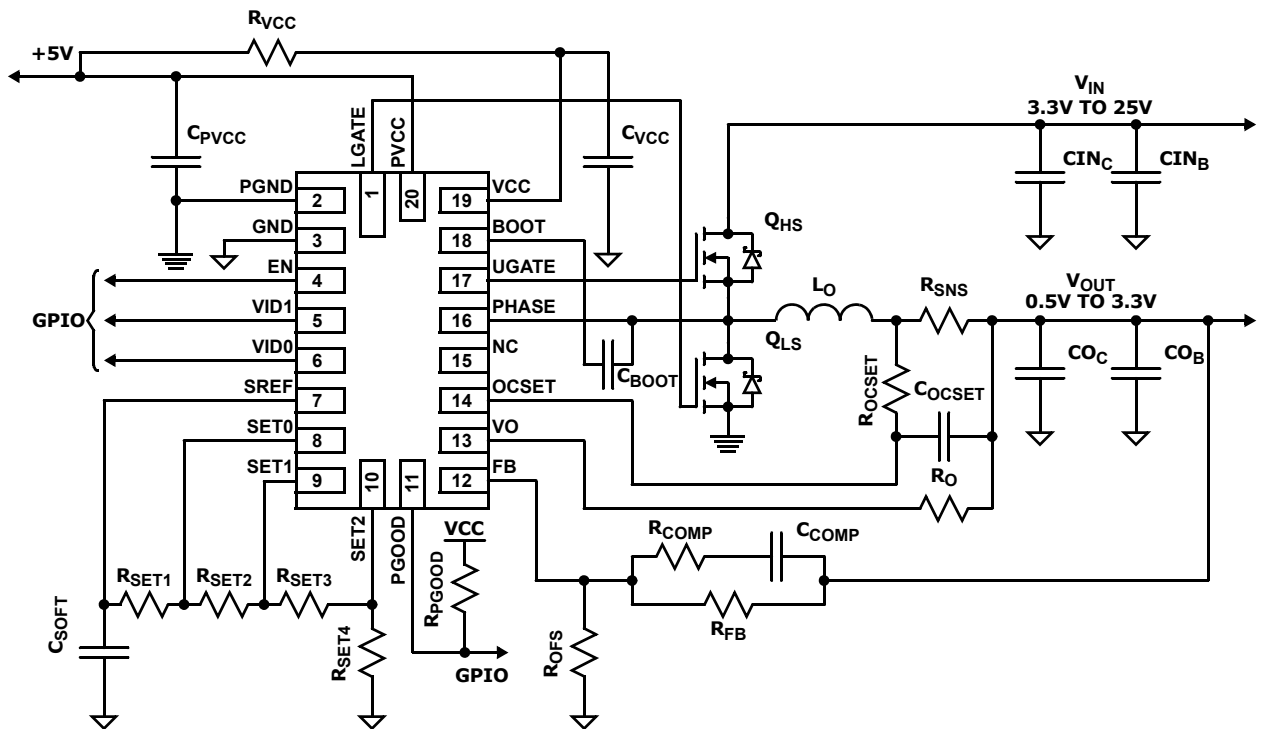

FIGURE 2. ISL62875 APPLICATION SCHEMATIC WITH FOUR OUTPUT VOLTAGE SETPOINTS AND RESISTOR CURRENT SENSE

## Application Schematics (Continued)

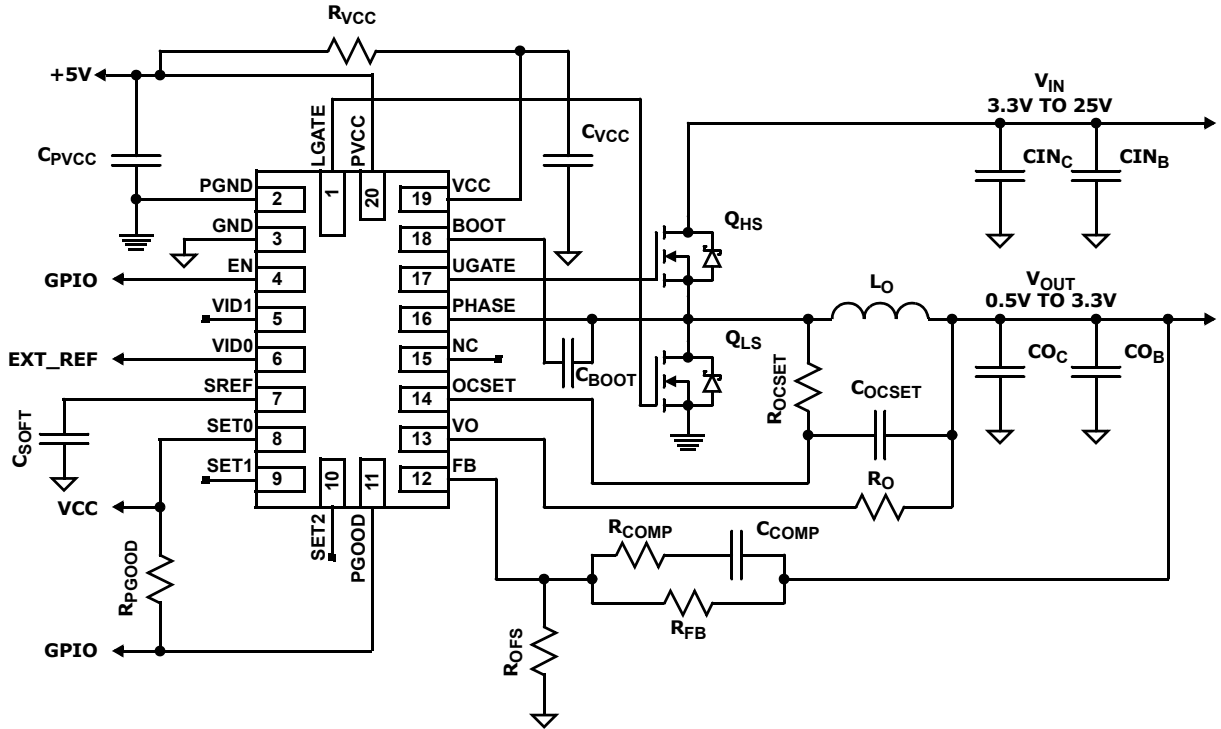

FIGURE 3. ISL62875 APPLICATION SCHEMATIC WITH EXTERNAL REFERENCE INPUT AND DCR CURRENT SENSE

# Block Diagram

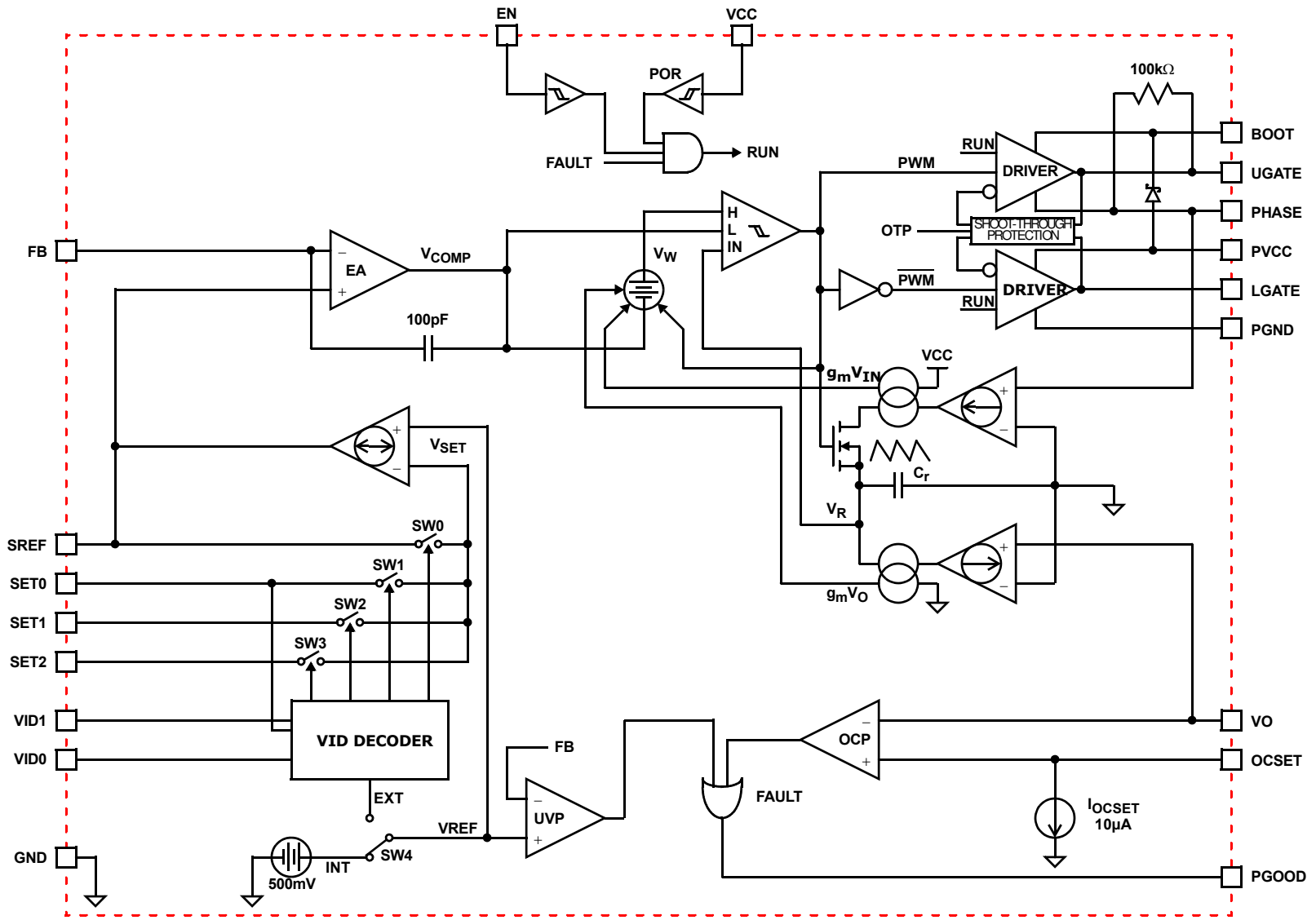
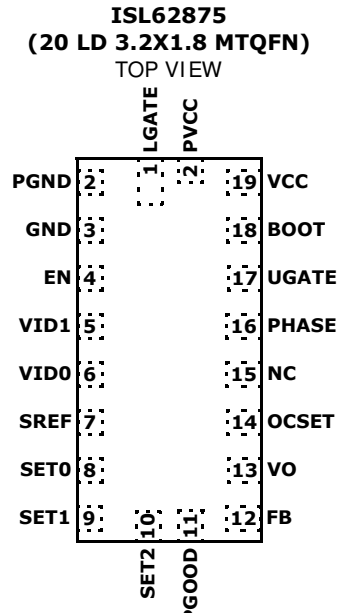

FIGURE 4. SIMPLIFIED FUNCTIONAL BLOCK DIAGRAM OF ISL62875

## Pin Configuration



## ISL62875 Functional Pin Descriptions

PIN NUMBER	SYMBOL	DESCRIPTION
1	LGATE	Low-side MOSFET gate driver output. Connect to the gate terminal of the low-side MOSFET of the converter.
2	PGND	Return current path for the LGATE MOSFET driver. Connect to the source of the low-side MOSFET.
3	GND	IC ground for bias supply and signal reference.
4	EN	Enable input for the IC. Pulling EN above the $V_{ENTHR}$ rising threshold voltage initializes the soft-start sequence.
5	VID1	Logic input for setpoint voltage selector. Use in conjunction with the VID0 pin to select among four setpoint reference voltages.
6	VID0	Logic input for setpoint voltage selector. Use in conjunction with the VID1 pin to select among four setpoint reference voltages. External reference input when enabled by connecting the SET0 pin to the VCC pin.
7	SREF	Soft-start and voltage slew-rate programming capacitor input. Setpoint reference voltage programming resistor input. Connects internally to the inverting input of the $V_{SET}$ voltage setpoint amplifier.
8	SET0	Voltage set-point programming resistor input.
9	SET1	Voltage set-point programming resistor input.
10	SET2	Voltage set-point programming resistor input.
11	PGOOD	Power-good open-drain indicator output. This pin changes to high impedance when the converter is able to supply regulated voltage. The pull-down resistance between the PGOOD pin and the GND pin identifies which protective fault has shut down the regulator.
12	FB	Voltage feedback sense input. Connects internally to the inverting input of the control-loop error amplifier. The converter is in regulation when the voltage at the FB pin equals the voltage on the SREF pin. The control loop compensation network connects between the FB pin and the converter output.
13	VO	Output voltage sense input for the $R^3$ modulator. The VO pin also serves as the reference input for the overcurrent detection circuit.

## ISL62875 Functional Pin Descriptions (Continued)

PIN NUMBER	SYMBOL	DESCRIPTION
14	OCSET	Input for the overcurrent detection circuit. The overcurrent setpoint programming resistor $R_{OCSET}$ connects from this pin to the sense node.
15	NC	No internal connection. Pin 15 should be connected to the GND pin.
16	PHASE	Return current path for the UGATE high-side MOSFET driver. $V_{IN}$ sense input for the $R^3$ modulator. Inductor current polarity detector input. Connect to junction of output inductor, high-side MOSFET, and low-side MOSFET. See Figures 1 and 2 on page 2.
17	UGATE	High-side MOSFET gate driver output. Connect to the gate terminal of the high-side MOSFET of the converter.
18	BOOT	Positive input supply for the UGATE high-side MOSFET gate driver. The BOOT pin is internally connected to the cathode of the Schottky boot-strap diode. Connect an MLCC between the BOOT pin and the PHASE pin.
19	VCC	Input for the IC bias voltage. Connect +5V to the VCC pin and decouple with at least a $1\mu\text{F}$ MLCC to the GND pin. See "Application Schematics" (Figures 1 and 2) on page 2.
20	PVCC	Input for the LGATE and UGATE MOSFET driver circuits. The PVCC pin is internally connected to the anode of the Schottky boot-strap diode. Connect +5V to the PVCC pin and decouple with a $10\mu\text{F}$ MLCC to the PGND pin. See "Application Schematics" (Figures 1 and 2) on page 2.

## Ordering Information

PART NUMBER (Notes 1, 2, 3)	PART MARKING	TEMP RANGE (°C)	PACKAGE (Pb-Free)	PKG. DWG. #
ISL62875HRUZ-T*	GAR	-10 to +100	20 Ld 3.2x1.8 $\mu\text{TQFN}$ (Tape and Reel)	L20.3.2x1.8

### NOTES:

1. Please refer to [TB347](#) for details on reel specifications.
2. These Intersil Pb-free plastic packaged products employ special Pb-free material sets; molding compounds/die attach materials and NiPdAu plate - e4 termination finish, which is RoHS compliant and compatible with both SnPb and Pb-free soldering operations. Intersil Pb-free products are MSL classified at Pb-free peak reflow temperatures that meet or exceed the Pb-free requirements of IPC/JEDEC J STD-020.
3. For Moisture Sensitivity Level (MSL), please see device information page for [ISL62875](#). For more information on MSL please see techbrief [TB363](#).

# Table of Contents

<b>Application Schematics</b> .....	<b>2</b>
<b>Block Diagram</b> .....	<b>4</b>
<b>Pin Configuration</b> .....	<b>5</b>
<b>ISL62875 Functional Pin Descriptions</b> .....	<b>5</b>
<b>Ordering Information</b> .....	<b>6</b>
<b>Absolute Maximum Ratings</b> .....	<b>8</b>
<b>Thermal Information</b> .....	<b>8</b>
<b>Recommended Operating Conditions</b> .....	<b>8</b>
<b>Electrical Specifications</b> .....	<b>8</b>
<b>Theory of Operation</b> .....	<b>11</b>
Modulator .....	11
Synchronous Rectification .....	11
Diode Emulation .....	11
Power-On Reset .....	12
V <sub>IN</sub> and PVCC Voltage Sequence .....	12
Start-Up Timing .....	12
PGOOD Monitor .....	12
LGATE and UGATE MOSFET Gate-Drivers .....	12
Adaptive Shoot-Through Protection .....	12
<b>Setpoint Reference Voltage Programming</b> .....	<b>13</b>
Calculating Setpoint Voltage Programming Resistor Values .....	13
External Setpoint Reference .....	14
<b>Soft-Start and Voltage-Step Delay</b> .....	<b>14</b>
Circuit Description .....	14
Component Selection For C <sub>SOFT</sub> Capacitor .....	15
<b>Compensation Design</b> .....	<b>15</b>
<b>Fault Protection</b> .....	<b>15</b>
Overcurrent .....	15
Component Selection for R <sub>OCSET</sub> and C <sub>SEN</sub> .....	16
Overvoltage .....	16
Undervoltage .....	16
Over-Temperature .....	16
<b>General Application Design Guide</b> .....	<b>16</b>
Selecting the LC Output Filter .....	17
Selection of the Input Capacitor .....	17
Selecting The Bootstrap Capacitor .....	17
Driver Power Dissipation .....	18
MOSFET Selection and Considerations .....	18
<b>PCB Layout Considerations</b> .....	<b>19</b>
Power and Signal Layers Placement on the PCB .....	19
Component Placement .....	19
Signal Ground and Power Ground .....	19
Routing and Connection Details .....	19
Copper Size for the Phase Node .....	20
<b>Revision History</b> .....	<b>21</b>
<b>Products</b> .....	<b>21</b>
<b>Package Outline Drawing</b> .....	<b>22</b>

## Absolute Maximum Ratings

VCC, PVCC, PGOOD to GND	-0.3V to +7.0V
VCC, PVCC to PGND	-0.3V to +7.0V
GND to PGND	-0.3V to +0.3V
EN, SET0, SET1, SET2, VO, VID0, VID1, FB, OCSET, SREF	-0.3V to GND, VCC + 0.3V
BOOT Voltage (V <sub>BOOT-GND</sub> )	-0.3V to 33V
BOOT To PHASE Voltage (V <sub>BOOT-PHASE</sub> )	-0.3V to 7V (DC) -0.3V to 9V (<10ns)
PHASE Voltage	GND - 0.3V to 28V GND -8V (<20ns Pulse Width, 10μJ)
UGATE Voltage	V <sub>PHASE</sub> - 0.3V (DC) to V <sub>BOOT</sub> V <sub>PHASE</sub> - 5V (<20ns Pulse Width, 10μJ) to V <sub>BOOT</sub>
LGATE Voltage	GND - 0.3V (DC) to VCC + 0.3V GND - 2.5V (<20ns Pulse Width, 5μJ) to VCC + 0.3V

## Thermal Information

Thermal Resistance (Typical)	$\theta_{JA}$ (°C/W)
20 Ld $\mu$ TQFN Package (Notes 4, 5)	84
Junction Temperature Range	-55°C to +150°C
Operating Temperature Range	-10°C to +100°C
Storage Temperature	-65°C to +150°C
Pb-free Reflow Profile	see link below <a href="http://www.intersil.com/pbfree/Pb-FreeReflow.asp">http://www.intersil.com/pbfree/Pb-FreeReflow.asp</a>

## Recommended Operating Conditions

Ambient Temperature Range	-10°C to +100°C
Converter Input Voltage to GND	3.3V to 25V
VCC, PVCC to GND	5V $\pm$ 5%

**CAUTION:** Do not operate at or near the maximum ratings listed for extended periods of time. Exposure to such conditions may adversely impact product reliability and result in failures not covered by warranty.

### NOTES:

- $\theta_{JA}$  is measured in free air with the component mounted on a high effective thermal conductivity test board with “direct attach” features. See Tech Brief TB379.
- For  $\theta_{JC}$ , the “case temp” location is the center of the exposed metal pad on the package underside.

**Electrical Specifications** These specifications apply for  $T_A = -10^\circ\text{C}$  to  $+100^\circ\text{C}$ , unless otherwise stated. All typical specifications  $T_A = +25^\circ\text{C}$ , VCC = 5V. **Boldface limits apply over the operating temperature range,  $-10^\circ\text{C}$  to  $+100^\circ\text{C}$ .**

PARAMETER	SYMBOL	TEST CONDITIONS	MIN (Note 7)	TYP	MAX (Note 7)	UNIT
<b>VCC and PVCC</b>						
VCC Input Bias Current	$I_{VCC}$	EN = 5V, VCC = 5V, FB = 0.55V, SREF < FB	-	1.1	<b>1.5</b>	mA
VCC Shutdown Current	$I_{VCCoff}$	EN = GND, VCC = 5V	-	0.1	<b>1.0</b>	μA
PVCC Shutdown Current	$I_{PVCCoff}$	EN = GND, PVCC = 5V	-	0.1	<b>1.0</b>	μA
<b>VCC POR THRESHOLD</b>						
Rising VCC POR Threshold Voltage	$V_{VCC\_THR}$		<b>4.40</b>	4.49	<b>4.60</b>	V
Falling VCC POR Threshold Voltage	$V_{VCC\_THF}$		<b>4.10</b>	4.22	<b>4.35</b>	V
<b>REGULATION</b>						
Reference Voltage	$V_{REF(int)}$		-	0.50	-	V
System Accuracy		VID0 = VID1 = GND, PWM Mode = CCM	<b>-0.75</b>	-	<b>+0.75</b>	%
<b>PWM</b>						
Switching Frequency	$F_{SW}$	PWM Mode = CCM	<b>450</b>	500	<b>550</b>	kHz
<b>VO</b>						
VO Input Voltage Range	$V_{VO}$		<b>0</b>	-	<b>3.6</b>	V
VO Input Impedance	$R_{VO}$	EN = 5V	-	600	-	kΩ
VO Reference Offset Current	$I_{VOSS}$	$V_{ENTHR} < EN$ , SREF = Soft-Start Mode	-	10	-	μA
VO Input Leakage Current	$I_{VOoff}$	EN = GND, VO = 3.6V	-	0.1	-	μA
<b>ERROR AMPLIFIER</b>						
FB Input Bias Current	$I_{FB}$	EN = 5V, FB = 0.50V	<b>-20</b>	-	<b>+50</b>	nA
<b>SREF</b>						
SREF Operating Voltage Range	$V_{SREF}$	Nominal SREF Setting with 1% Resistors	<b>0.5</b>	-	<b>1.5</b>	V
Soft-Start Current	$I_{SS}$	SREF = Soft-Start Mode	<b>10</b>	20	<b>30</b>	μA



**Electrical Specifications** These specifications apply for  $T_A = -10^\circ\text{C}$  to  $+100^\circ\text{C}$ , unless otherwise stated.  
 All typical specifications  $T_A = +25^\circ\text{C}$ ,  $V_{CC} = 5\text{V}$ . **Boldface limits apply over the operating temperature range,  $-10^\circ\text{C}$  to  $+100^\circ\text{C}$ . (Continued)**

PARAMETER	SYMBOL	TEST CONDITIONS	MIN (Note 7)	TYP	MAX (Note 7)	UNIT
Voltage Step Current	$I_{VS}$	SREF = Setpoint-Stepping Mode	<b><math>\pm 60</math></b>	$\pm 100$	<b><math>\pm 140</math></b>	$\mu\text{A}$
<b>EXTERNAL REFERENCE</b>						
EXTREF Operating Voltage Range	$V_{EXT}$	SET0 = VCC	<b>0</b>	-	<b>1.5</b>	V
EXTREF Accuracy	$V_{EXT\_OFS}$	SET0 = VCC, VID0 = 0V to 1.5V	<b>-0.5</b>	-	<b>+0.5</b>	%
<b>POWER GOOD</b>						
PGOOD Pull-down Impedance	$R_{PG\_SS}$	PGOOD = 5mA Sink	<b>75</b>	95	<b>150</b>	$\Omega$
	$R_{PG\_UV}$	PGOOD = 5mA Sink	<b>75</b>	95	<b>150</b>	$\Omega$
	$R_{PG\_OV}$	PGOOD = 5mA Sink	<b>50</b>	65	<b>90</b>	$\Omega$
	$R_{PG\_OC}$	PGOOD = 5mA Sink	<b>25</b>	35	<b>50</b>	$\Omega$
PGOOD Leakage Current	$I_{PG}$	PGOOD = 5V	-	0.1	<b>1.0</b>	$\mu\text{A}$
PGOOD Maximum Sink Current (Note 6)	$I_{PG\_max}$		-	5.0	-	mA
<b>GATE DRIVER</b>						
UGATE Pull-Up Resistance (Note 6)	$R_{UGPU}$	200mA Source Current	-	1.0	<b>1.5</b>	$\Omega$
UGATE Source Current (Note 6)	$I_{UGSRC}$	UGATE - PHASE = 2.5V	-	2.0	-	A
UGATE Sink Resistance (Note 6)	$R_{UGPD}$	250mA Sink Current	-	1.0	<b>1.5</b>	$\Omega$
UGATE Sink Current (Note 6)	$I_{UGSNK}$	UGATE - PHASE = 2.5V	-	2.0	-	A
LGATE Pull-Up Resistance (Note 6)	$R_{LGPU}$	250mA Source Current	-	1.0	<b>1.5</b>	$\Omega$
LGATE Source Current (Note 6)	$I_{LGSRC}$	LGATE - GND = 2.5V	-	2.0	-	A
LGATE Sink Resistance (Note 6)	$R_{LGPD}$	250mA Sink Current	-	0.5	<b>0.9</b>	$\Omega$
LGATE Sink Current (Note 6)	$I_{LGSNK}$	LGATE - PGND = 2.5V	-	4.0	-	A
UGATE to LGATE Deadtime	$t_{UGFLGR}$	UGATE falling to LGATE rising, no load	-	21	-	ns
LGATE to UGATE Deadtime	$t_{LGFUGR}$	LGATE falling to UGATE rising, no load	-	21	-	ns
<b>PHASE</b>						
PHASE Input Impedance	$R_{PHASE}$		-	33	-	k $\Omega$
<b>BOOTSTRAP DIODE</b>						
Forward Voltage	$V_F$	PVCC = 5V, $I_F = 2\text{mA}$	-	0.58	-	V
Reverse Leakage	$I_R$	$V_R = 25\text{V}$	-	0.2	-	$\mu\text{A}$
<b>CONTROL INPUTS</b>						
EN High Threshold Voltage	$V_{ENTHR}$		<b>2.0</b>	-	-	V
EN Low Threshold Voltage	$V_{ENTHF}$		-	-	<b>1.0</b>	V
EN Input Bias Current	$I_{EN}$	EN = 5V	<b>1.5</b>	2.0	<b>2.5</b>	$\mu\text{A}$
EN Leakage Current	$I_{ENoff}$	EN = GND	-	0.1	<b>1.0</b>	$\mu\text{A}$
VID<0,1> High Threshold Voltage	$V_{VIDTHR}$		<b>0.6</b>	-	-	V
VID<0,1> Low Threshold Voltage	$V_{VIDTHF}$		-	-	<b>0.5</b>	V
VID<0,1> Input Bias Current	$I_{VID}$	EN = 5V, $V_{VID} = 1\text{V}$	-	0.5	-	$\mu\text{A}$
VID<0,1> Leakage Current	$I_{VIDoff}$		-	0	-	$\mu\text{A}$

**Electrical Specifications** These specifications apply for  $T_A = -10^\circ\text{C}$  to  $+100^\circ\text{C}$ , unless otherwise stated.  
 All typical specifications  $T_A = +25^\circ\text{C}$ ,  $V_{CC} = 5\text{V}$ . **Boldface limits apply over the operating temperature range,  $-10^\circ\text{C}$  to  $+100^\circ\text{C}$ . (Continued)**

PARAMETER	SYMBOL	TEST CONDITIONS	MIN (Note 7)	TYP	MAX (Note 7)	UNIT
<b>PROTECTION</b>						
OCP Threshold Voltage	$V_{OCPTH}$	$V_{OCSET} - V_O$	<b>-1.75</b>	-	<b>1.75</b>	mV
OCP Reference Current	$I_{OCP}$	EN = 5.0V	<b>9.0</b>	10	<b>11</b>	$\mu\text{A}$
OCSET Input Resistance	$R_{OCSET}$	EN = 5.0V	-	600	-	$\text{k}\Omega$
OCSET Leakage Current	$I_{OCSET}$	EN = GND	-	0	-	$\mu\text{A}$
UVP Threshold Voltage	$V_{UVTH}$	$V_{FB} = \% V_{SREF}$	<b>81</b>	84	<b>87</b>	%
OTP Rising Threshold Temperature (Note 6)	$T_{OTRTH}$		-	150	-	$^\circ\text{C}$
OTP Hysteresis (Note 6)	$T_{OTHYS}$		-	25	-	$^\circ\text{C}$

## NOTES:

- Limits established by characterization and are not production tested.
- Parameters with MIN and/or MAX limits are 100% tested at  $+25^\circ\text{C}$ , unless otherwise specified. Temperature limits established by characterization and are not production tested.

## Theory of Operation

The modulator features Intersil's R<sup>3</sup> Robust-Ripple-Regulator technology, a hybrid of fixed frequency PWM control and variable frequency hysteretic control. The PWM frequency is maintained at 500kHz under static continuous-conduction-mode operation within the entire specified envelope of input voltage, output voltage, and output load. If the application should experience a rising load transient and/or a falling line transient such that the output voltage starts to fall, the modulator will extend the on-time and/or reduce the off-time of the PWM pulse in progress. Conversely, if the application should experience a falling load transient and/or a rising line transient such that the output voltage starts to rise, the modulator will truncate the on-time and/or extend the off-time of the PWM pulse in progress. The period and duty cycle of the ensuing PWM pulses are optimized by the R<sup>3</sup> modulator for the remainder of the transient and work in concert with the error amplifier  $V_{ERR}$  to maintain output voltage regulation. Once the transient has dissipated and the control loop has recovered, the PWM frequency returns to the nominal static 500kHz.

### Modulator

The R<sup>3</sup> modulator synthesizes an AC signal  $V_R$ , which is an analog representation of the output inductor ripple current. The duty-cycle of  $V_R$  is the result of charge and discharge current through a ripple capacitor  $C_R$ . The current through  $C_R$  is provided by a transconductance amplifier  $g_m$  that measures the input voltage ( $V_{IN}$ ) at the PHASE pin and output voltage ( $V_{OUT}$ ) at the VO pin. The positive slope of  $V_R$  can be written as Equation 1:

$$V_{RPOS} = (g_m) \cdot (V_{IN} - V_{OUT}) / C_R \quad (\text{EQ. 1})$$

The negative slope of  $V_R$  can be written as Equation 2:

$$V_{RNEG} = g_m \cdot V_{OUT} / C_R \quad (\text{EQ. 2})$$

Where,  $g_m$  is the gain of the transconductance amplifier.

A window voltage  $V_W$  is referenced with respect to the error amplifier output voltage  $V_{COMP}$  creating an envelope into which the ripple voltage  $V_R$  is compared. The amplitude of  $V_W$  is controlled internally by the IC. The  $V_R$ ,  $V_{COMP}$ , and  $V_W$  signals feed into a window comparator in which  $V_{COMP}$  is the lower threshold voltage and  $V_W$  is the higher threshold voltage. Figure 5 shows PWM pulses being generated as  $V_R$  traverses the  $V_W$  and  $V_{COMP}$  thresholds. The PWM switching frequency is proportional to the slew rates of the positive and negative slopes of  $V_R$ ; it is inversely proportional to the voltage between  $V_W$  and  $V_{COMP}$ .

### Synchronous Rectification

A standard DC/DC buck regulator uses a free-wheeling diode to maintain uninterrupted current conduction through the output inductor when the high-side MOSFET switches off for the balance of the PWM switching cycle. Low conversion efficiency as a result of the conduction loss of the diode makes this an unattractive option for all but the lowest current applications. Efficiency is dramatically improved when the free-wheeling diode is

replaced with a MOSFET that is turned on whenever the high-side MOSFET is turned off. This modification to the standard DC/DC buck regulator is referred to as synchronous rectification, the topology implemented by the ISL62875 controller.

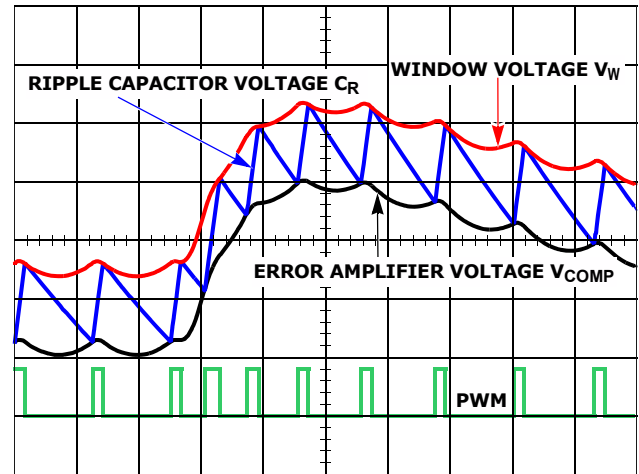

FIGURE 5. MODULATOR WAVEFORMS DURING LOAD TRANSIENT

### Diode Emulation

The polarity of the output inductor current is defined as positive when conducting away from the phase node, and defined as negative when conducting towards the phase node. The DC component of the inductor current is positive, but the AC component known as the ripple current, can be either positive or negative. Should the sum of the AC and DC components of the inductor current remain positive for the entire switching period, the converter is in continuous-conduction-mode (CCM.) However, if the inductor current becomes negative or zero, the converter is in discontinuous-conduction-mode (DCM.)

Unlike the standard DC/DC buck regulator, the synchronous rectifier can sink current from the output filter inductor during DCM, reducing the light-load efficiency with unnecessary conduction loss as the low-side MOSFET sinks the inductor current. The ISL62875 controller avoids the DCM conduction loss by making the low-side MOSFET emulate the current-blocking behavior of a diode. This smart-diode operation called diode-emulation-mode (DEM) is triggered when the negative inductor current produces a positive voltage drop across the  $r_{DS(ON)}$  of the low-side MOSFET for eight consecutive PWM cycles while the LGATE pin is high. The converter will exit DEM on the next PWM pulse after detecting a negative voltage across the  $r_{DS(ON)}$  of the low-side MOSFET.

It is characteristic of the R<sup>3</sup> architecture for the PWM switching frequency to decrease while in DCM, increasing efficiency by reducing unnecessary gate-driver switching losses. The extent of the frequency reduction is proportional to the reduction of load current. Upon entering DEM, the PWM frequency is forced to fall approximately 30% by forcing a similar increase of the

window voltage  $V_W$ . This measure is taken to prevent oscillating between modes at the boundary between CCM and DCM. The 30% increase of  $V_W$  is removed upon exit of DEM, forcing the PWM switching frequency to jump back to the nominal CCM value.

### Power-On Reset

The IC is disabled until the voltage at the VCC pin has increased above the rising power-on reset (POR) threshold voltage  $V_{VCC\_THR}$ . The controller will become disabled when the voltage at the VCC pin decreases below the falling POR threshold voltage  $V_{VCC\_THF}$ . The POR detector has a noise filter of approximately 1  $\mu$ s.

### $V_{IN}$ and $PVCC$ Voltage Sequence

Prior to pulling EN above the  $V_{ENTHR}$  rising threshold voltage, the following criteria must be met:

- $V_{PVCC}$  is at least equivalent to the VCC rising power-on reset voltage  $V_{VCC\_THR}$
- $V_{VIN}$  must be 3.3V or the minimum required by the application

### Start-Up Timing

Once VCC has ramped above  $V_{VCC\_THR}$ , the controller can be enabled by pulling the EN pin voltage above the input-high threshold  $V_{ENTHR}$ . Approximately 20  $\mu$ s later, the voltage at the SREF pin begins slewing to the designated VID set-point. The converter output voltage at the FB feedback pin follows the voltage at the SREF pin. During soft-start, The regulator always operates in CCM until the soft-start sequence is complete.

### PGOOD Monitor

The PGOOD pin indicates when the converter is capable of supplying regulated voltage. The PGOOD pin is an undefined impedance if the VCC pin has not reached the rising POR threshold  $V_{VCC\_THR}$ , or if the VCC pin is below the falling POR threshold  $V_{VCC\_THF}$ . The PGOOD pull-down resistance corresponds to a specific protective fault, thereby reducing troubleshooting time and effort. Table 1 maps the pull-down resistance of the PGOOD pin to the corresponding fault status of the controller.

**TABLE 1. PGOOD PULL-DOWN RESISTANCE**

CONDITION	PGOOD RESISTANCE
VCC Below POR	Undefined
Soft-Start or Undervoltage	95 $\Omega$
Overcurrent	35 $\Omega$

### LGATE and UGATE MOSFET Gate-Drivers

The LGATE pin and UGATE pins are MOSFET driver outputs. The LGATE pin drives the low-side MOSFET of the converter while the UGATE pin drives the high-side MOSFET of the converter.

The LGATE driver is optimized for low duty-cycle applications where the low-side MOSFET experiences long conduction times. In this environment, the low-side MOSFETs require exceptionally low  $r_{DS(ON)}$  and tend to have large parasitic charges that conduct transient currents within the devices in response to high dv/dt switching present at the phase node. The drain-gate charge in particular can conduct sufficient current through the driver pull-down resistance that the  $V_{GS(th)}$  of the device can be exceeded and turned on. For this reason the LGATE driver has been designed with low pull-down resistance and high sink current capability to ensure clamping the MOSFETs gate voltage below  $V_{GS(th)}$ .

### Adaptive Shoot-Through Protection

Adaptive shoot-through protection prevents a gate-driver output from turning on until the opposite gate-driver output has fallen below approximately 1V. The dead-time shown in Figure 6 is extended by the additional period that the falling gate voltage remains above the 1V threshold. The high-side gate-driver output voltage is measured across the UGATE and PHASE pins while the low-side gate-driver output voltage is measured across the LGATE and PGND pins. The power for the LGATE gate-driver is sourced directly from the PVCC pin. The power for the UGATE gate-driver is supplied by a bootstrap capacitor connected across the BOOT and PHASE pins. The capacitor is charged each time the phase node voltage falls a diode drop below  $PVCC$  such as when the low-side MOSFET is turned on.

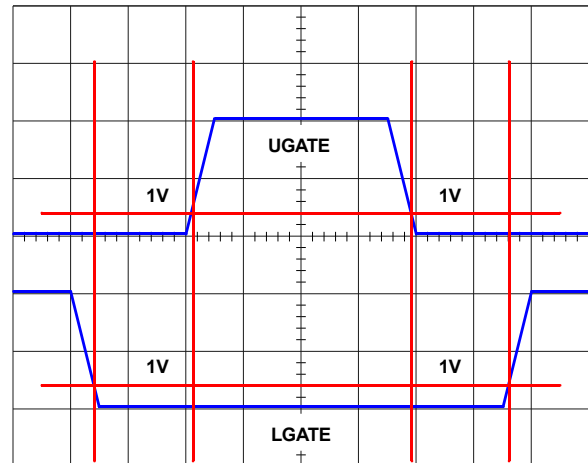

**FIGURE 6. GATE DRIVER ADAPTIVE SHOOT-THROUGH**

## Setpoint Reference Voltage Programming

Voltage identification (VID) pins select user-programmed setpoint reference voltages that appear at the SREF pin. The converter is in regulation when the FB pin voltage ( $V_{FB}$ ) equals the SREF pin voltage ( $V_{SREF}$ ). The IC measures  $V_{FB}$  and  $V_{SREF}$  relative to the GND pin, not the PGND pin. The setpoint reference voltages use the naming convention  $V_{SET(x)}$  where (x) is the first, second, third, or fourth setpoint reference voltage where:

- $V_{SET1} < V_{SET2} < V_{SET3} < V_{SET4}$
- $V_{OUT1} < V_{OUT2} < V_{OUT3} < V_{OUT4}$

The  $V_{SET1}$  setpoint is fixed at 500mV because it corresponds to the closure of internal switch SW0 that configures the  $V_{SET}$  amplifier as a unity-gain voltage follower for the 500mV voltage reference  $V_{REF}$ .

A feedback voltage-divider network may be required to achieve the desired reference voltages. Using the feedback voltage-divider allows the maximum output voltage of the converter to be higher than the 1.5V maximum setpoint reference voltage that can be programmed on the SREF pin. Likewise, the feedback voltage-divider allows the minimum output voltage of the converter to be higher than the fixed 500mV setpoint reference voltage of  $V_{SET1}$ . Scale the voltage-divider network such that the voltage  $V_{FB}$  equals the voltage  $V_{SREF}$  when the converter output voltage is at the desired level. The voltage-divider relation is given in Equation 3:

$$V_{FB} = V_{OUT} \cdot \frac{R_{OFS}}{R_{FB} + R_{OFS}} \quad (\text{EQ. 3})$$

Where:

- $V_{FB} = V_{SREF}$
- $R_{FB}$  is the loop-compensation feedback resistor that connects from the FB pin to the converter output
- $R_{OFS}$  is the voltage-scaling programming resistor that connects from the FB pin to the GND pin

The attenuation of the feedback voltage divider is written as:

$$K = \frac{V_{SREF(lim)}}{V_{OUT(lim)}} = \frac{R_{OFS}}{R_{FB} + R_{OFS}} \quad (\text{EQ. 4})$$

Where:

- $K$  is the attenuation factor
- $V_{SREF(lim)}$  is the  $V_{SREF}$  voltage setpoint of either 500mV or 1.50V
- $V_{OUT(lim)}$  is the output voltage of the converter when  $V_{SREF} = V_{SREF(lim)}$

Since the voltage-divider network is in the feedback path, all output voltage setpoints will be attenuated by  $K$ , so it follows that all of the setpoint reference voltages will be attenuated by  $K$ . It will be necessary then to include

the attenuation factor  $K$  in all the calculations for selecting the  $R_{SET}$  programming resistors.

The value of offset resistor  $R_{OFS}$  can be calculated only after the value of loop-compensation resistor  $R_{FB}$  has been determined. The calculation of  $R_{OFS}$  is written as Equation 5:

$$R_{OFS} = \frac{V_{SET(x)} \cdot R_{FB}}{V_{OUT} - V_{SET(x)}} \quad (\text{EQ. 5})$$

The setpoint reference voltages are programmed with resistors that use the naming convention  $R_{SET(x)}$  where (x) is the first, second, third, or fourth programming resistor connected in series starting at the SREF pin and ending at the GND pin. When one of the internal switches closes, it connects the inverting input of the  $V_{SET}$  amplifier to a specific node among the string of  $R_{SET}$  programming resistors. All the resistors between that node and the SREF pin serve as the feedback impedance  $R_F$  of the  $V_{SET}$  amplifier. Likewise, all the resistors between that node and the GND pin serve as the input impedance  $R_{IN}$  of the  $V_{SET}$  amplifier. Equation 6 gives the general form of the gain equation for the  $V_{SET}$  amplifier:

$$V_{SET(x)} = V_{REF} \cdot \left( 1 + \frac{R_F}{R_{IN}} \right) \quad (\text{EQ. 6})$$

Where:

- $V_{REF}$  is the 500mV internal reference of the IC
- $V_{SET(x)}$  is the resulting setpoint reference voltage that appears at the SREF pin

### Calculating Setpoint Voltage Programming Resistor Values

TABLE 2. ISL62875 VID TRUTH TABLE

VID STATE		RESULT		
VID1	VID0	CLOSE	$V_{SREF}$	$V_{OUT}$
1	1	SW0	$V_{SET1}$	$V_{OUT1}$
1	0	SW1	$V_{SET2}$	$V_{OUT2}$
0	1	SW2	$V_{SET3}$	$V_{OUT3}$
0	0	SW3	$V_{SET4}$	$V_{OUT4}$

First, determine the attenuation factor  $K$ . Next, assign an initial value to  $R_{SET4}$  of approximately 100k $\Omega$  then calculate  $R_{SET1}$ ,  $R_{SET2}$ , and  $R_{SET3}$  using Equations 7, 8, and 9 respectively. The equation for the value of  $R_{SET1}$  is written as Equation 7:

$$R_{SET1} = \frac{R_{SET4} \cdot KV_{SET4} \cdot (KV_{SET2} - V_{REF})}{V_{REF} \cdot KV_{SET2}} \quad (\text{EQ. 7})$$

The equation for the value of  $R_{SET2}$  is written as Equation 8:

$$R_{SET2} = \frac{R_{SET4} \cdot KV_{SET4} \cdot (KV_{SET3} - KV_{SET2})}{KV_{SET2} \cdot KV_{SET3}} \quad (\text{EQ. 8})$$

The equation for the value of  $R_{SET3}$  is written as Equation 9:

$$R_{SET3} = \frac{R_{SET4} \cdot (KV_{SET4} - KV_{SET3})}{KV_{SET3}} \quad (\text{EQ. 9})$$

The sum of all the programming resistors should be approximately 300kΩ as shown in Equation 10 otherwise adjust the value of  $R_{SET4}$  and repeat the calculations.

$$R_{SET1} + R_{SET2} + R_{SET3} + R_{SET4} \approx 300k\Omega \quad (\text{EQ. 10})$$

Equations 11, 12, 13 and 14 give the specific  $V_{SET}$  gain equations for the ISL62875 setpoint reference voltages.

The ISL62875  $V_{SET1}$  setpoint is written as Equation 11:  
 $V_{SET1} = V_{REF}$  (EQ. 11)

The ISL62875  $V_{SET2}$  setpoint is written as Equation 12:

$$V_{SET2} = V_{REF} \cdot \left( 1 + \frac{R_{SET1}}{R_{SET2} + R_{SET3} + R_{SET4}} \right) \quad (\text{EQ. 12})$$

The ISL62875  $V_{SET3}$  setpoint is written as Equation 13:

$$V_{SET3} = V_{REF} \cdot \left( 1 + \frac{R_{SET1} + R_{SET2}}{R_{SET3} + R_{SET4}} \right) \quad (\text{EQ. 13})$$

The ISL62875  $V_{SET4}$  setpoint is written as Equation 14:

$$V_{SET4} = V_{REF} \cdot \left( 1 + \frac{R_{SET1} + R_{SET2} + R_{SET3}}{R_{SET4}} \right) \quad (\text{EQ. 14})$$

**External Setpoint Reference**

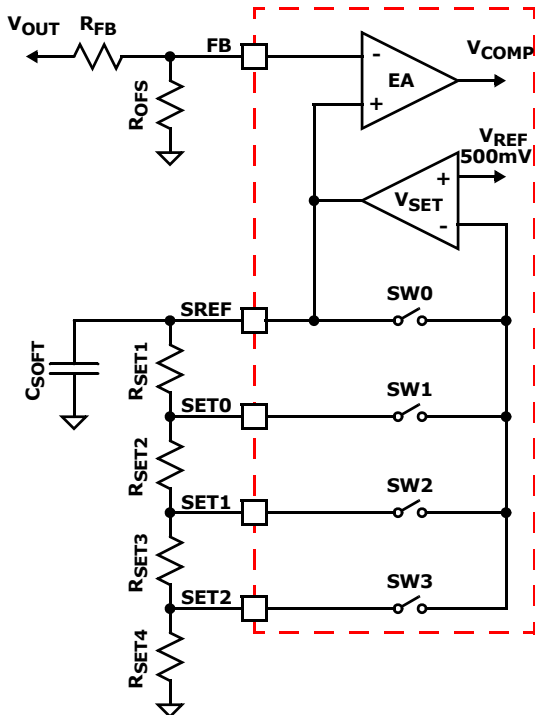

**FIGURE 7. VOLTAGE PROGRAMMING CIRCUIT**

The IC can use an external setpoint reference voltage as an alternative to VID-selected, resistor-programmed setpoints. This is accomplished by removing all setpoint programming resistors, connecting the SET0 pin to the VCC pin, and feeding the external setpoint reference

voltage to the VID0 pin. When SET0 and VCC are tied together, the following internal reconfigurations take place:

- VID0 pin opens its 500nA pull-down current sink
- Reference source selector switch SW4 moves from INT position (internal 500mV) to EXT position (VID0 pin)
- VID1 pin is disabled

The converter will now be in regulation when the voltage on the FB pin equals the voltage on the VID0 pin. As with resistor-programmed setpoints, the reference voltage range on the VID0 pin is 500mV to 1.5V. Use Equations 3, 4, and 5 beginning on page 13 should it become necessary to implement an output voltage-divider network to make the external setpoint reference voltage compatible with the 500mV to 1.5V constraint.

**Soft-Start and Voltage-Step Delay**

**Circuit Description**

When the voltage on the VCC pin has ramped above the rising power-on reset voltage  $V_{VCC\_THR}$ , and the voltage on the EN pin has increased above the rising enable threshold voltage  $V_{ENTHR}$ , the SREF pin releases its discharge clamp and enables the reference amplifier  $V_{SET}$ . The soft-start current  $I_{SS}$  is limited to 20μA and is sourced out of the SREF pin into the parallel RC network of capacitor  $C_{SOFT}$  and resistance  $R_T$ . The resistance  $R_T$  is the sum of all the series connected  $R_{SET}$  programming resistors and is written as Equation 15:

$$R_T = R_{SET1} + R_{SET2} + \dots + R_{SET(n)} \quad (\text{EQ. 15})$$

The voltage on the SREF pin rises as  $I_{SS}$  charges  $C_{SOFT}$  to the voltage reference setpoint selected by the state of the VID inputs at the time the EN pin is asserted. The regulator controls the PWM such that the voltage on the FB pin tracks the rising voltage on the SREF pin. Once  $C_{SOFT}$  charges to the selected setpoint voltage, the  $I_{SS}$  current source comes out of the 20μA current limit and decays to the static value set by  $V_{SREF} \div R_T$ . The elapsed time from when the EN pin is asserted to when  $V_{SREF}$  has reached the voltage reference setpoint is the soft-start delay  $t_{SS}$  which is given by Equation 16:

$$t_{SS} = -(R_T \cdot C_{SOFT}) \cdot \text{LN} \left( 1 - \frac{V_{START-UP}}{I_{SS} \cdot R_T} \right) \quad (\text{EQ. 16})$$

Where:

- $I_{SS}$  is the soft-start current source at the 20μA limit
- $V_{START-UP}$  is the setpoint reference voltage selected by the state of the VID inputs at the time EN is asserted
- $R_T$  is the sum of the  $R_{SET}$  programming resistors

The end of soft-start is detected by  $I_{SS}$  tapering off when capacitor  $C_{SOFT}$  charges to the designated  $V_{SET}$  voltage



reference setpoint. The SSOK flag is set, the PGOOD pin goes high, and the I<sub>SS</sub> current source changes over to the voltage-step current source I<sub>VS</sub> which has a current limit of ±100µA. Whenever the VID inputs or the external setpoint reference, programs a different setpoint reference voltage, the I<sub>VS</sub> current source charges or discharges capacitor C<sub>SOFT</sub> to that new level at ±100µA. Once C<sub>SOFT</sub> charges to the selected setpoint voltage, the I<sub>VS</sub> current source comes out of the 100µA current limit and decays to the static value set by V<sub>SREF</sub> ÷ R<sub>T</sub>. The elapsed time to charge C<sub>SOFT</sub> to the new voltage is called the voltage-step delay t<sub>VS</sub> and is given by Equation 17:

$$t_{VS} = -(R_T \cdot C_{SOFT}) \cdot \ln\left(1 - \frac{(V_{NEW} - V_{OLD})}{I_{VS} \cdot R_T}\right) \quad (\text{EQ. 17})$$

Where:

- I<sub>VS</sub> is the ±100µA setpoint voltage-step current
- V<sub>NEW</sub> is the new setpoint voltage selected by the VID inputs
- V<sub>OLD</sub> is the setpoint voltage that V<sub>NEW</sub> is changing from
- R<sub>T</sub> is the sum of the R<sub>SET</sub> programming resistors

### Component Selection For C<sub>SOFT</sub> Capacitor

Choosing the C<sub>SOFT</sub> capacitor to meet the requirements of a particular soft-start delay t<sub>SS</sub> is calculated with Equation 18, which is written as:

$$C_{SOFT} = \frac{-t_{SS}}{\left(R_T \cdot \ln\left(1 - \frac{V_{START-UP}}{I_{SS} \cdot R_T}\right)\right)} \quad (\text{EQ. 18})$$

Where:

- t<sub>SS</sub> is the soft-start delay
- I<sub>SS</sub> is the soft-start current source at the 20µA limit
- V<sub>START-UP</sub> is the setpoint reference voltage selected by the state of the VID inputs at the time EN is asserted
- R<sub>T</sub> is the sum of the R<sub>SET</sub> programming resistors

Choosing the C<sub>SOFT</sub> capacitor to meet the requirements of a particular voltage-step delay t<sub>VS</sub> is calculated with Equation 19, which is written as:

$$C_{SOFT} = \frac{-t_{VS}}{\left(R_T \cdot \ln\left(1 - \frac{V_{NEW} - V_{OLD}}{\pm I_{VS} \cdot R_T}\right)\right)} \quad (\text{EQ. 19})$$

Where:

- t<sub>VS</sub> is the voltage-step delay
- V<sub>NEW</sub> is the new setpoint voltage
- V<sub>OLD</sub> is the setpoint voltage that V<sub>NEW</sub> is changing from
- I<sub>VS</sub> is the ±100µA setpoint voltage-step current; positive when V<sub>NEW</sub> > V<sub>OLD</sub>, negative when V<sub>NEW</sub> < V<sub>OLD</sub>
- R<sub>T</sub> is the sum of the R<sub>SET</sub> programming resistors

## Compensation Design

Figure 8 shows the recommended Type-II compensation circuit. The FB pin is the inverting input of the error amplifier. The COMP signal, the output of the error amplifier, is inside the chip and unavailable to users. C<sub>INT</sub> is a 100pF capacitor integrated inside the IC, connecting across the FB pin and the COMP signal. R<sub>FB</sub>, R<sub>COMP</sub>, C<sub>COMP</sub> and C<sub>INT</sub> form the Type-II compensator. The frequency domain transfer function is given by Equation 20:

$$G_{COMP}(s) = \frac{1 + s \cdot (R_{FB} + R_{COMP}) \cdot C_{COMP}}{s \cdot R_{FB} \cdot C_{INT} \cdot (1 + s \cdot R_{COMP} \cdot C_{COMP})} \quad (\text{EQ. 20})$$

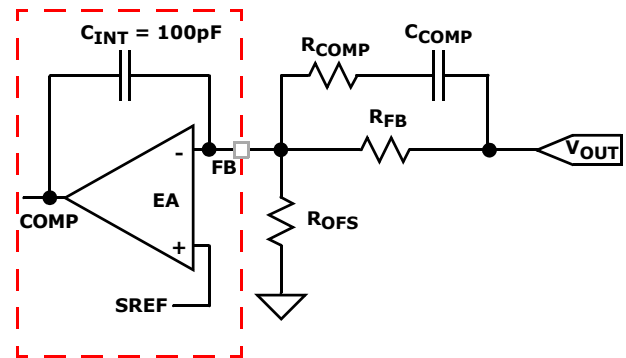

FIGURE 8. COMPENSATION REFERENCE CIRCUIT

The LC output filter has a double pole at its resonant frequency that causes rapid phase change. The R<sup>3</sup> modulator used in the IC makes the LC output filter resemble a first order system in which the closed loop stability can be achieved with the recommended Type-II compensation network. Intersil provides a PC-based tool that can be used to calculate compensation network component values and help simulate the loop frequency response.

## Fault Protection

### Overcurrent

The overcurrent protection (OCP) setpoint is programmed with resistor R<sub>OCSET</sub> which is connected across the OCSET and PHASE pins. Resistor R<sub>O</sub> is connected between the VO pin and the actual output voltage of the converter. During normal operation, the VO pin is a high impedance path, therefore there is no voltage drop across R<sub>O</sub>. The value of resistor R<sub>O</sub> should always match the value of resistor R<sub>OCSET</sub>.

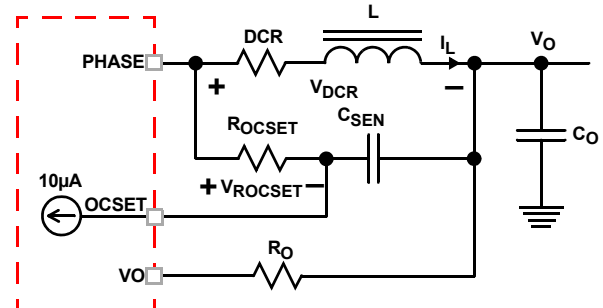

FIGURE 9. OVERCURRENT PROGRAMMING CIRCUIT

Figure 9 shows the overcurrent set circuit. The inductor consists of inductance L and the DC resistance DCR. The inductor DC current  $I_L$  creates a voltage drop across DCR, which is given by Equation 21:

$$V_{DCR} = I_L \cdot DCR \quad (\text{EQ. 21})$$

The  $I_{OCSET}$  current source sinks  $10\mu\text{A}$  into the OCSET pin, creating a DC voltage drop across the resistor  $R_{OCSET}$ , which is given by Equation 22:

$$V_{ROCSET} = 10\mu\text{A} \cdot R_{OCSET} \quad (\text{EQ. 22})$$

The DC voltage difference between the OCSET pin and the VO pin, which is given by Equation 23:

$$V_{OCSET} - V_{VO} = V_{DCR} - V_{ROCSET} = I_L \cdot DCR - I_{OCSET} \cdot R_{OCSET} \quad (\text{EQ. 23})$$

The IC monitors the voltage of the OCSET pin and the VO pin. When the voltage of the OCSET pin is higher than the voltage of the VO pin for more than  $10\mu\text{s}$ , an OCP fault latches the converter off.

### Component Selection for $R_{OCSET}$ and $C_{SEN}$

The value of  $R_{OCSET}$  is calculated with Equation 24, which is written as:

$$R_{OCSET} = \frac{I_{OC} \cdot DCR}{I_{OCSET}} \quad (\text{EQ. 24})$$

Where:

- $R_{OCSET}$  ( $\Omega$ ) is the resistor used to program the overcurrent setpoint
- $I_{OC}$  is the output DC load current that will activate the OCP fault detection circuit
- DCR is the inductor DC resistance

For example, if  $I_{OC}$  is 20A and DCR is  $4.5\text{m}\Omega$ , the choice of  $R_{OCSET}$  is  $= 20\text{A} \times 4.5\text{m}\Omega / 10\mu\text{A} = 9\text{k}\Omega$ .

Resistor  $R_{OCSET}$  and capacitor  $C_{SEN}$  form an R-C network to sense the inductor current. To sense the inductor current correctly not only in DC operation, but also during dynamic operation, the R-C network time constant  $R_{OCSET} C_{SEN}$  needs to match the inductor time constant  $L/DCR$ . The value of  $C_{SEN}$  is then written as Equation 25:

$$C_{SEN} = \frac{L}{R_{OCSET} \cdot DCR} \quad (\text{EQ. 25})$$

For example, if L is  $1.5\mu\text{H}$ , DCR is  $4.5\text{m}\Omega$  and  $R_{OCSET}$  is  $9\text{k}\Omega$ , the choice of  $C_{SEN} = 1.5\mu\text{H} / (9\text{k}\Omega \times 4.5\text{m}\Omega) = 0.037\mu\text{F}$ .

When an OCP fault is declared, the PGOOD pin will pull-down to  $35\Omega$  and latch off the converter. The fault will remain latched until the EN pin has been pulled below the falling EN threshold voltage  $V_{ENTHF}$  or if VCC has decayed below the falling POR threshold voltage  $V_{VCC\_THF}$

### Overvoltage

The ISL62875 does not feature overvoltage fault protection.

### Undervoltage

The UVP fault detection circuit triggers after the FB pin voltage is below the undervoltage threshold  $V_{UVTH}$  for more than  $2\mu\text{s}$ . For example, if the converter is programmed to regulate 1.0V at the FB pin, that voltage would have to fall below the typical  $V_{UVTH}$  threshold of 84% for more than  $2\mu\text{s}$  in order to trip the UVP fault latch. In numerical terms, that would be  $84\% \times 1.0\text{V} = 0.84\text{V}$ . When a UVP fault is declared, the PGOOD pin will pull-down to  $95\Omega$  and latch-off the converter. The fault will remain latched until the EN pin has been pulled below the falling EN threshold voltage  $V_{ENTHF}$  or if VCC has decayed below the falling POR threshold voltage  $V_{VCC\_THF}$

### Over-Temperature

When the temperature of the IC increases above the rising threshold temperature  $T_{OTRTH}$ , it will enter the OTP state that suspends the PWM, forcing the LGATE and UGATE gate-driver outputs low. The status of the PGOOD pin does not change nor does the converter latch-off. The PWM remains suspended until the IC temperature falls below the hysteresis temperature  $T_{OTHYS}$  at which time normal PWM operation resumes. The OTP state can be reset if the EN pin is pulled below the falling EN threshold voltage  $V_{ENTHF}$  or if VCC has decayed below the falling POR threshold voltage  $V_{VCC\_THF}$ . All other protection circuits remain functional while the IC is in the OTP state. It is likely that the IC will detect an UVP fault because in the absence of PWM, the output voltage decays below the undervoltage threshold  $V_{UVTH}$ .

## General Application Design Guide

This design guide is intended to provide a high-level explanation of the steps necessary to design a single-phase power converter. It is assumed that the reader is familiar with many of the basic skills and techniques referenced in the following. In addition to this guide, Intersil provides complete reference designs that include schematics, bills of materials, and example board layouts.

### Selecting the LC Output Filter

The duty cycle of an ideal buck converter is a function of the input and the output voltage. This relationship is expressed in Equation 26:

$$D = \frac{V_O}{V_{IN}} \quad (\text{EQ. 26})$$

The output inductor peak-to-peak ripple current is expressed in Equation 27:

$$I_{P-P} = \frac{V_O \cdot (1 - D)}{F_{SW} \cdot L} \quad (\text{EQ. 27})$$



A typical step-down DC/DC converter will have an  $I_{P,P}$  of 20% to 40% of the maximum DC output load current.

The value of  $I_{P,P}$  is selected based upon several criteria, such as MOSFET switching loss, inductor core loss, and the resistive loss of the inductor winding. The DC copper loss of the inductor can be estimated using Equation 28:

$$P_{\text{COPPER}} = I_{\text{LOAD}}^2 \cdot \text{DCR} \quad (\text{EQ. 28})$$

Where,  $I_{\text{LOAD}}$  is the converter output DC current.

The copper loss can be significant so attention has to be given to the DCR selection. Another factor to consider when choosing the inductor is its saturation characteristics at elevated temperature. A saturated inductor could cause destruction of circuit components, as well as nuisance OCP faults.

A DC/DC buck regulator must have output capacitance  $C_O$  into which ripple current  $I_{P,P}$  can flow. Current  $I_{P,P}$  develops a corresponding ripple voltage  $V_{P,P}$  across  $C_O$ , which is the sum of the voltage drop across the capacitor ESR and of the voltage change stemming from charge moved in and out of the capacitor. These two voltages are expressed in Equations 29 and 30:

$$\Delta V_{\text{ESR}} = I_{P,P} \cdot \text{ESR} \quad (\text{EQ. 29})$$

$$\Delta \Delta V_C = \frac{I_{P,P}}{8 \cdot C_O \cdot F_{\text{SW}}} \quad (\text{EQ. 30})$$

If the output of the converter has to support a load with high pulsating current, several capacitors will need to be paralleled to reduce the total ESR until the required  $V_{P,P}$  is achieved. The inductance of the capacitor can cause a brief voltage dip if the load transient has an extremely high slew rate. Low inductance capacitors should be considered. A capacitor dissipates heat as a function of RMS current and frequency. Be sure that  $I_{P,P}$  is shared by a sufficient quantity of paralleled capacitors so that they operate below the maximum rated RMS current at  $F_{\text{SW}}$ . Take into account that the rated value of a capacitor can fade as much as 50% as the DC voltage across it increases.

### Selection of the Input Capacitor

The important parameters for the bulk input capacitance are the voltage rating and the RMS current rating. For reliable operation, select bulk capacitors with voltage and current ratings above the maximum input voltage and capable of supplying the RMS current required by the switching circuit. Their voltage rating should be at least 1.25x greater than the maximum input voltage, while a voltage rating of 1.5x is a preferred rating. Figure 10 is a graph of the input RMS ripple current, normalized relative to output load current, as a function of duty cycle that is adjusted for converter efficiency. The ripple current calculation is written as Equation 31:

$$I_{\text{IN\_RMS}} = \frac{\sqrt{(I_{\text{MAX}}^2 \cdot (D - D^2)) + (x \cdot I_{\text{MAX}}^2 \cdot \frac{D}{12})}}{I_{\text{MAX}}} \quad (\text{EQ. 31})$$

Where:

- $I_{\text{MAX}}$  is the maximum continuous  $I_{\text{LOAD}}$  of the converter
- $x$  is a multiplier (0 to 1) corresponding to the inductor peak-to-peak ripple amplitude expressed as a percentage of  $I_{\text{MAX}}$  (0% to 100%)
- $D$  is the duty cycle that is adjusted to take into account the efficiency of the converter

Duty cycle is written as Equation 32:

$$D = \frac{V_O}{V_{\text{IN}} \cdot \text{EFF}} \quad (\text{EQ. 32})$$

In addition to the bulk capacitance, some low ESL ceramic capacitance is recommended to decouple between the drain of the high-side MOSFET and the source of the low-side MOSFET.

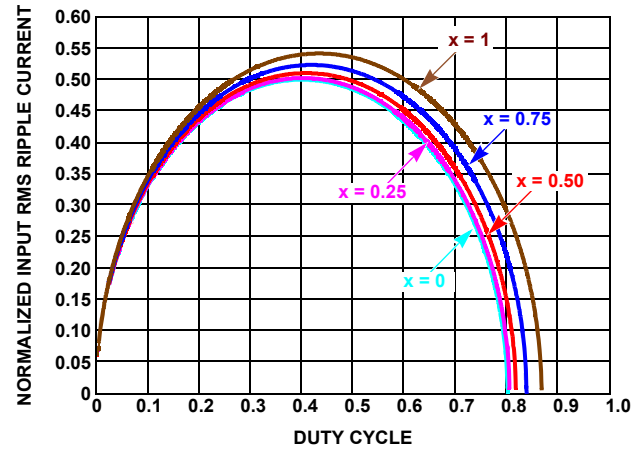

FIGURE 10. NORMALIZED RMS INPUT CURRENT FOR  $x = 0.8$

### Selecting The Bootstrap Capacitor

Adding an external capacitor across the BOOT and PHASE pins completes the bootstrap circuit. We selected the bootstrap capacitor breakdown voltage to be at least 10V. Although the theoretical maximum voltage of the capacitor is  $V_{\text{VCC}} - V_{\text{DIODE}}$  (voltage drop across the boot diode), large excursions below ground by the phase node requires we select a capacitor with at least a breakdown rating of 10V. The bootstrap capacitor can be chosen from Equation 33:

$$C_{\text{BOOT}} \geq \frac{Q_{\text{GATE}}}{\Delta V_{\text{BOOT}}} \quad (\text{EQ. 33})$$

Where:

- $Q_{\text{GATE}}$  is the amount of gate charge required to fully charge the gate of the upper MOSFET
- $\Delta V_{\text{BOOT}}$  is the maximum decay across the BOOT capacitor

As an example, suppose an upper MOSFET has a gate charge,  $Q_{\text{GATE}}$ , of 25nC at 5V and also assume the droop in the drive voltage over a PWM cycle is 200mV. One will find that a bootstrap capacitance of at least 0.125 $\mu\text{F}$  is required. The next larger standard value capacitance is

0.15µF. A good quality ceramic capacitor such as X7R or X5R is recommended.

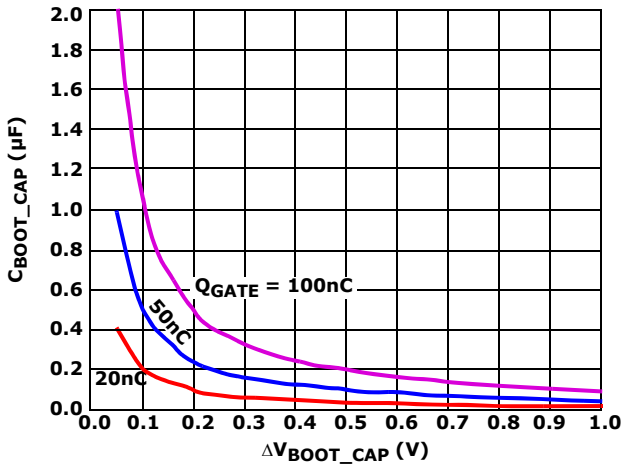

**FIGURE 11. BOOT CAPACITANCE vs BOOT RIPPLE VOLTAGE**

**Driver Power Dissipation**

Switching power dissipation in the driver is mainly a function of the switching frequency and total gate charge of the selected MOSFETs. Calculating the power dissipation in the driver for a desired application is critical to ensuring safe operation. Exceeding the maximum allowable power dissipation level will push the IC beyond the maximum recommended operating junction temperature of + 125°C. When designing the application, it is recommended that the following calculation be performed to ensure safe operation at the desired frequency for the selected MOSFETs. The power dissipated by the drivers is approximated as Equation 34:

$$P = F_{sw}(1.5V_U Q_U + V_L Q_L) + P_L + P_U \tag{EQ. 34}$$

Where:

- $F_{sw}$  is the switching frequency of the PWM signal
- $V_U$  is the upper gate driver bias supply voltage
- $V_L$  is the lower gate driver bias supply voltage
- $Q_U$  is the charge to be delivered by the upper driver into the gate of the MOSFET and discrete capacitors
- $Q_L$  is the charge to be delivered by the lower driver into the gate of the MOSFET and discrete capacitors
- $P_L$  is the quiescent power consumption of the lower driver
- $P_U$  is the quiescent power consumption of the upper driver

**MOSFET Selection and Considerations**

Typically, a MOSFET cannot tolerate even brief excursions beyond their maximum drain to source voltage rating. The MOSFETs used in the power stage of the converter should have a maximum  $V_{DS}$  rating that exceeds the sum of the upper voltage tolerance of the input power

source and the voltage spike that occurs when the MOSFET switches off.

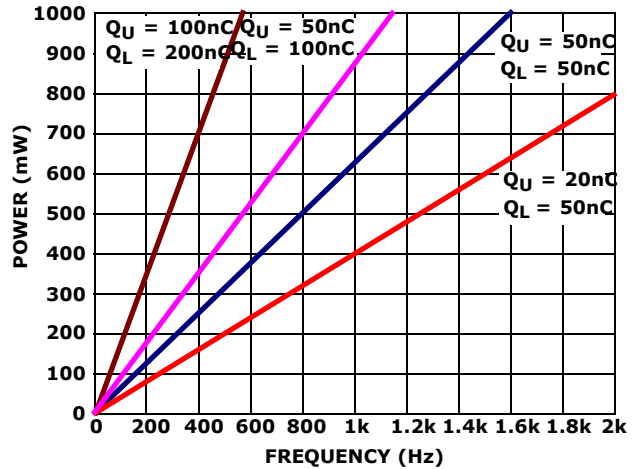

**FIGURE 12. POWER DISSIPATION vs FREQUENCY**

There are several power MOSFETs readily available that are optimized for DC/DC converter applications. The preferred high-side MOSFET emphasizes low switch charge so that the device spends the least amount of time dissipating power in the linear region. Unlike the low-side MOSFET which has the drain-source voltage clamped by its body diode during turn-off, the high-side MOSFET turns off with  $V_{IN} - V_{OUT}$ , plus the spike, across it. The preferred low-side MOSFET emphasizes low  $r_{DS(ON)}$  when fully saturated to minimize conduction loss.

For the low-side MOSFET, (LS), the power loss can be assumed to be conductive only and is written as Equation 35:

$$P_{CON\_LS} \approx I_{LOAD}^2 \cdot r_{DS(ON)\_LS} \cdot (1 - D) \tag{EQ. 35}$$

For the high-side MOSFET, (HS), its conduction loss is written as Equation 36:

$$P_{CON\_HS} = I_{LOAD}^2 \cdot r_{DS(ON)\_HS} \cdot D \tag{EQ. 36}$$

For the high-side MOSFET, its switching loss is written as Equation 37:

$$P_{SW\_HS} = \frac{V_{IN} \cdot I_{VALLEY} \cdot t_{ON} \cdot F_{SW}}{2} + \frac{V_{IN} \cdot I_{PEAK} \cdot t_{OFF} \cdot F_{SW}}{2} \tag{EQ. 37}$$

Where:

- $I_{VALLEY}$  is the difference of the DC component of the inductor current minus 1/2 of the inductor ripple current
- $I_{PEAK}$  is the sum of the DC component of the inductor current plus 1/2 of the inductor ripple current
- $t_{ON}$  is the time required to drive the device into saturation

- $t_{OFF}$  is the time required to drive the device into cut-off

## PCB Layout Considerations

### Power and Signal Layers Placement on the PCB

As a general rule, power layers should be close together, either on the top or bottom of the board, with the weak analog or logic signal layers on the opposite side of the board. The ground-plane layer should be adjacent to the signal layer to provide shielding. The ground plane layer should have an island located under the IC, the compensation components, and the SREF components. The island should be connected to the rest of the ground plane layer at one point.

### Component Placement

There are two sets of critical components in a DC/DC converter; the power components and the small signal components. The power components are the most critical because they switch large amount of energy. The small signal components connect to sensitive nodes or supply critical bypassing current and signal coupling.

The power components should be placed first and these include MOSFETs, input and output capacitors, and the inductor. Keeping the distance between the power train and the control IC short helps keep the gate drive traces short. These drive signals include the LGATE, UGATE, PGND, PHASE and BOOT.

When placing MOSFETs, try to keep the source of the upper MOSFETs and the drain of the lower MOSFETs as close as thermally possible (see Figure 13). Input high-frequency capacitors should be placed close to the drain of the upper MOSFETs and the source of the lower MOSFETs. Place the output inductor and output capacitors between the MOSFETs and the load. High-frequency output decoupling capacitors (ceramic) should be placed as close as possible to the decoupling target (GPU or CPU), making use of the shortest connection paths to any internal planes. Place the components in such a way that the area under the IC has less noise traces with high  $dV/dt$  and  $di/dt$ , such as gate signals and phase node signals.

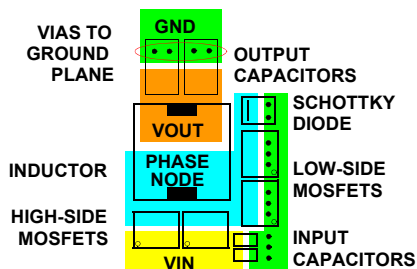

FIGURE 13. TYPICAL POWER COMPONENT PLACEMENT

### Signal Ground and Power Ground

The GND pin is the signal-common also known as analog ground of the IC. When laying out the PCB, it is very important that the connection of the GND pin to the bottom setpoint-reference programming-resistor, bottom feedback voltage-divider resistor (if used), and the CSOFT capacitor be made as close as possible to the GND pin on a conductor not shared by any other components.

In addition to the critical single point connection discussed in the previous paragraph, the ground plane layer of the PCB should have a single-point-connected island located under the area encompassing the IC, setpoint reference programming components, feedback voltage divider components, compensation components, CSOFT capacitor, and the interconnecting traces among the components and the IC. The island should be connected using several filled vias to the rest of the ground plane layer at one point that is not in the path of either large static currents or high  $di/dt$  currents. The single connection point should also be where the VCC decoupling capacitor and the GND pin of the IC are connected.

Anywhere not within the analog-ground island is Power Ground. Connect the input capacitor(s), the output capacitor(s), and the source of the lower MOSFET(s) to the power ground plane.

### Routing and Connection Details

Specific pins (and the trace routing from them), require extra attention during the layout process. The following sub-sections outline concerns by pin name.

#### VCC PIN

For best performance, place the decoupling capacitor next to the VCC and GND pins. The VCC decoupling capacitor should not share any vias with the PVCC decoupling capacitor.

#### PVCC PIN

For best performance, place the PVCC decoupling capacitor next to the PVCC and PGND pins, preferably on the same side of the PCB as the ISL62875. The PVCC decoupling capacitor should have a very short and wide trace connection to the PGND pin.

#### EN, PGOOD, VID0, AND VID1 PINS

These are logic signals that are referenced to the GND pin. Treat as a typical logic signal.

#### OCSET AND VO PINS

The current-sensing network consisting of  $R_{OCSET}$ ,  $R_O$ , and  $C_{SEN}$  must be connected to the inductor pads for accurate measurement of the DCR voltage drop. These components however, should be located physically close to the OCSET and VO pins with traces leading back to the inductor. It is critical that the traces are shielded by the ground plane layer all the way to the inductor pads. The procedure is the same for resistive current sense.

**FB, SREF, SET0, SET1, AND SET2 PINS**

The input impedance of these pins is high, making it critical to place the loop compensation components, setpoint reference programming resistors, feedback voltage divider resistors, and CSOFT close to the IC, keeping the length of the traces short.

**LGATE, PGND, UGATE, BOOT, AND PHASE PINS**

The signals going through these traces are both high  $dv/dt$  and  $di/dt$ , with high peak charging and discharging current. The PGND pin can only flow current from the gate-source charge of the low-side MOSFETs when LGATE goes low. Ideally, route the trace from the LGATE pin in parallel with the trace from the PGND pin, route the trace from the UGATE pin in parallel with the trace from the PHASE pin, and route the trace from the BOOT pin in parallel with the trace from the PHASE pin. These pairs of traces should be short, wide, and away from other traces with high input impedance; weak signal traces should not be in proximity with these traces on any layer.

**Copper Size for the Phase Node**

The parasitic capacitance and parasitic inductance of the phase node should be kept very low to minimize ringing. It is best to limit the size of the PHASE node copper in strict accordance with the current and thermal management of the application. An MLCC should be connected directly across the drain of the upper MOSFET and the source of the lower MOSFET to suppress the turn-off voltage.

## Revision History

The revision history provided is for informational purposes only and is believed to be accurate, but not warranted. Please go to web to make sure you have the latest Rev.

DATE	REVISION	CHANGE
8/09	FN6905.0	Initial Release
9/09	FN6905.1	Page 10: Removed "OVP Rising Threshold Voltage" and "OVP Falling Threshold Voltage" lines from the "Electrical Specifications" table.

## Products

Intersil Corporation is a leader in the design and manufacture of high-performance analog semiconductors. The Company's products address some of the industry's fastest growing markets, such as, flat panel displays, cell phones, handheld products, and notebooks. Intersil's product families address power management and analog signal processing functions. Go to [www.intersil.com/products](http://www.intersil.com/products) for a complete list of Intersil product families.

\* For a complete listing of Applications, Related Documentation and Related Parts, please see the respective device information page on intersil.com: [ISL62875](http://www.intersil.com/ISL62875)

To report errors or suggestions for this datasheet, please go to [www.intersil.com/askourstaff](http://www.intersil.com/askourstaff)

FITs are available from our website at <http://rel.intersil.com/reports/search.php>

© Copyright Intersil Americas LLC 2009. All Rights Reserved.

All trademarks and registered trademarks are the property of their respective owners.

For additional products, see [www.intersil.com/en/products.html](http://www.intersil.com/en/products.html)

Intersil products are manufactured, assembled and tested utilizing ISO9001 quality systems as noted in the quality certifications found at [www.intersil.com/en/support/qualandreliability.html](http://www.intersil.com/en/support/qualandreliability.html)

*Intersil products are sold by description only. Intersil may modify the circuit design and/or specifications of products at any time without notice, provided that such modification does not, in Intersil's sole judgment, affect the form, fit or function of the product. Accordingly, the reader is cautioned to verify that datasheets are current before placing orders. Information furnished by Intersil is believed to be accurate and reliable. However, no responsibility is assumed by Intersil or its subsidiaries for its use; nor for any infringements of patents or other rights of third parties which may result from its use. No license is granted by implication or otherwise under any patent or patent rights of Intersil or its subsidiaries.*

For information regarding Intersil Corporation and its products, see [www.intersil.com](http://www.intersil.com)

# Package Outline Drawing

## L20.3.2x1.8

20 LEAD ULTRA THIN QUAD FLAT NO-LEAD PLASTIC PACKAGE (UTQFN)

Rev 0, 5/08

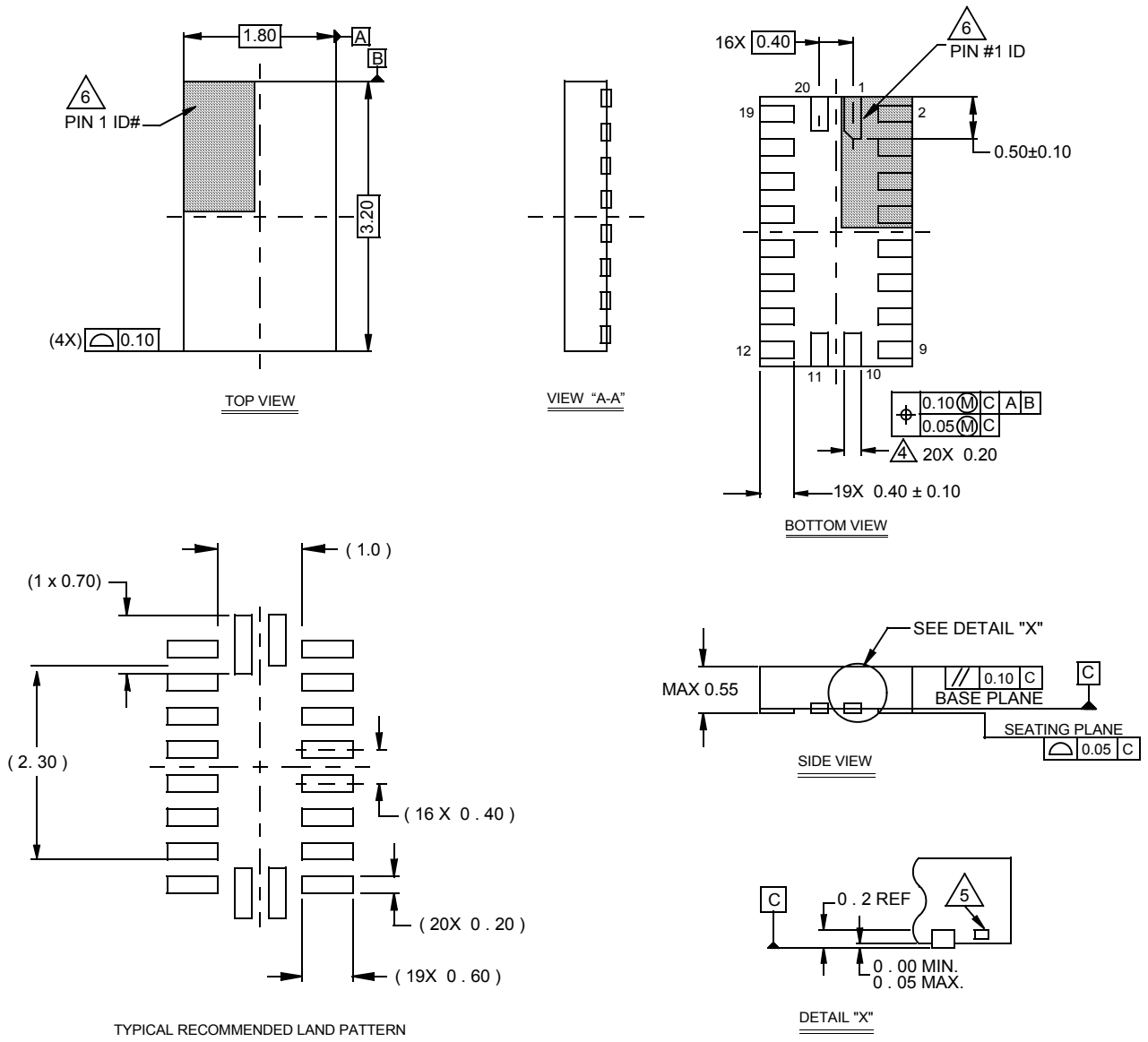

**NOTES:**

1. Dimensions are in millimeters.  
Dimensions in ( ) for Reference Only.
2. Dimensioning and tolerancing conform to AMSE Y14.5m-1994.
3. Unless otherwise specified, tolerance : Decimal ± 0.05
4. Dimension b applies to the metallized terminal and is measured between 0.15mm and 0.30mm from the terminal tip.
5. Tiebar shown (if present) is a non-functional feature.
6. The configuration of the pin #1 identifier is optional, but must be located within the zone indicated. The pin #1 identifier may be either a mold or mark feature.