

**NOTES:**

1. FOR WAVESOLDERING (SOLDER BATH TEMPERATURE 240°C FOR 5sec./ AND SOLDER PREHEAT 120°C FOR 120 SEC.)
2. METAL SHELLS: COPPER ALLOY; min. 315µm TIN over 40-80µm NICKEL
3. INSULATORS: PBT GF UL 94 V-0, BLACK
4. CONTACTS: COPPER ALLOY  
PLATING: 8µm HARD GOLD over min. 50µm NICKEL
5. THREADED SPACER CLIPS: COPPER ALLOY; min. 200µm TIN over 80µm NICKEL  
PCB-HOLE:  $\varnothing 3.1 \pm 0.1$ ; PCB THICKNESS 1.6mm
6. COLLARS: COPPER ALLOY; min. 200µm TIN over 80µm NICKEL
7. FRAME: ZINC DIE CAST; NICKEL PLATED
8. HEXLOCKING SCREWS: STAINLESS STEEL
9. O-RING: SILICON; BLUE
10. P.C.B. HOLE DRILLINGS + RECOMMENDED PANEL CUT OUT SEE SHEET 2
11. RECOMMENDED TORQUE FOR MOUNTING SCREW  
35Ncm (3.1 in.LB) / max. 40Ncm (3.5 in.LB)
12. CONNECTOR IS PART MARKED: 6HDD15SAR99E20X CONEC ABC

AT ALL TIMES WATER RESISTANT CONNECTORS NOT IN USE SHOULD BE COVERED WITH A CONEC WATER RESISTANT CAP OR WATER TIGHT HOOD

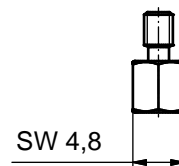
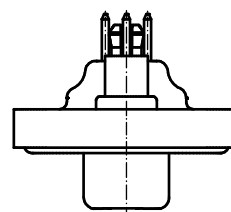
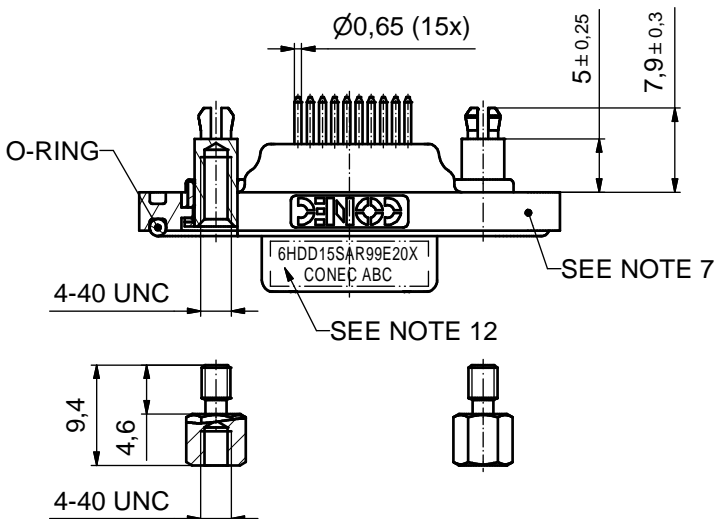
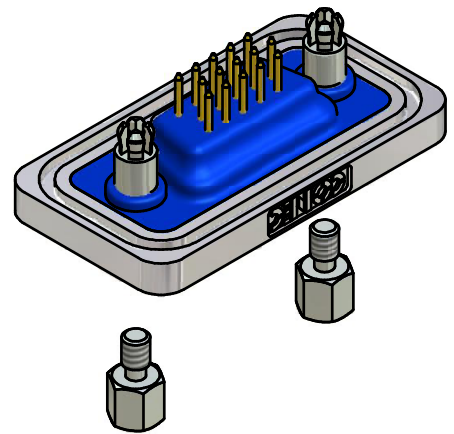
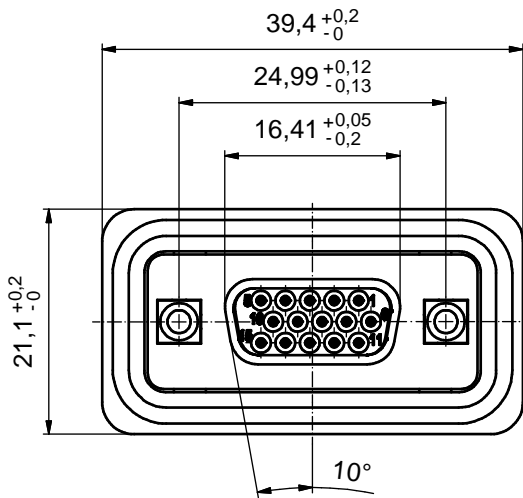
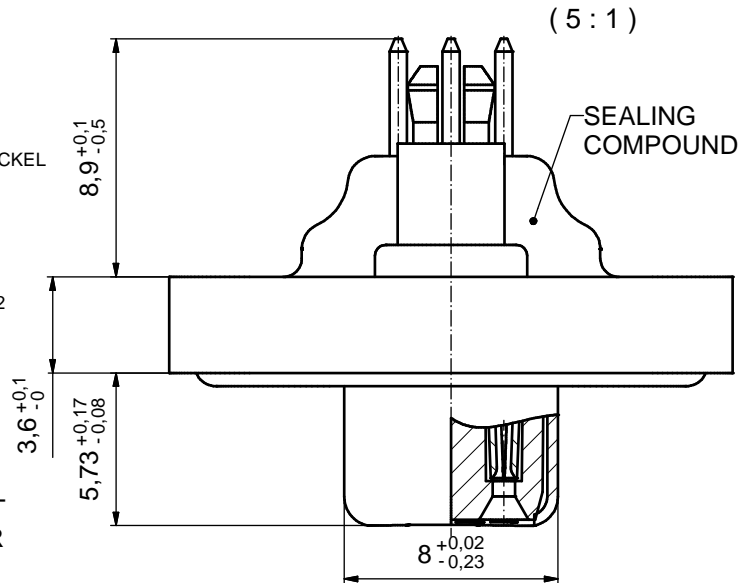

Directive 2002/95/EC  
RoHS  
Compliant

APPROVAL # FREIGABE # DEBLOCAGE # AUTORIZACION # APPROVAL	
CUSTOMER APPROVAL DATE:	
NAME:	TITLE:
COMPANY NAME:	
APPROVAL # FREIGABE # DEBLOCAGE # AUTORIZACION # APPROVAL	

THIS DRAWING MAY NOT BE COPIED OR REPRODUCED IN ANY WAY, AND MAY NOT BE PASSED ON TO A THIRD PARTY WITHOUT WRITTEN PERMISSION. OWNERSHIP AND COPYRIGHT OF CONEC GmbH			
DO NOT ALTER CAD DRAWING BY HAND			
rev.	description	date	name
a	Origin		

tolerance		dim. in mm
drawn	date	
appd.	name	
norm		
d-old		

scale:	2:1 (5:1)	
material:	SEE NOTES	
title:	D-SUB HD FEMALE 15pos. SOLDER PIN STRAIGHT with threaded spacer clip and hexlocking screw	
dwg no:	Inventor 10	DIN-A3
	15K1A382	sh: 1
part no:	6HDD15SAR99E20X	



P.C.B. HOLE DRILLINGS  
(P.C.B. TOP SIDE)

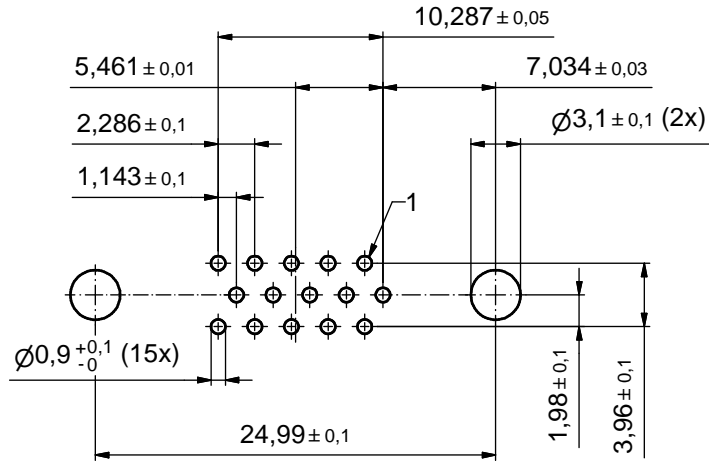

RECOMMENDED PANEL CUT-OUT

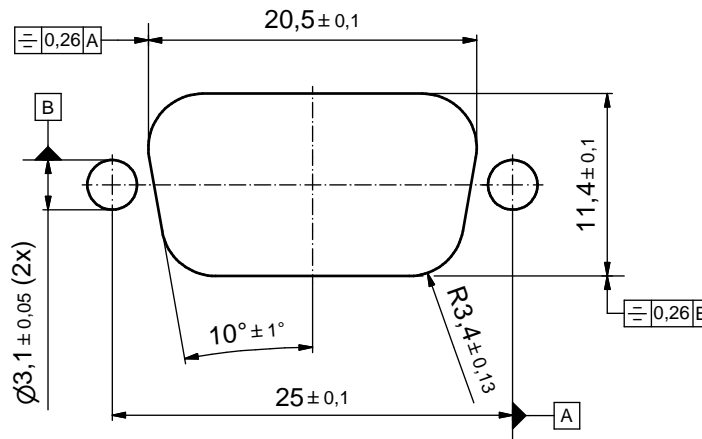

APPROVAL # FREIGABE # DEBLOCAGE # AUTORIZACION # APPROVAL	
CUSTOMER APPROVAL DATE:	
NAME:	TITLE:
COMPANY NAME:	
APPROVAL # FREIGABE # DEBLOCAGE # AUTORIZACION # APPROVAL	

THIS DRAWING MAY NOT BE COPIED OR REPRODUCED IN ANY WAY, AND MAY NOT BE PASSED ON TO A THIRD PARTY WITHOUT WRITTEN PERMISSION. OWNERSHIP AND COPYRIGHT OF CONEC GmbH			
DO NOT ALTER CAD DRAWING BY HAND			
rev.	description	date	name
a	Origin		

tolerance		 dim. in mm
drawn	date	
appd.	name	
norm		
d-old		

scale:	3:1	
material:	see sheet 1	
title:	P.C.B. HOLE DRILLINGS PANEL CUT-OUT Female 15pos. HD Solder pin straight	
dwg no:	Inventor 10	DIN-A3
	15K1A382	sh: 2
part no:	SEE SHEET 1	