

P.C.B. HOLE DRILLINGS  
(P.C.B. TOP SIDE)

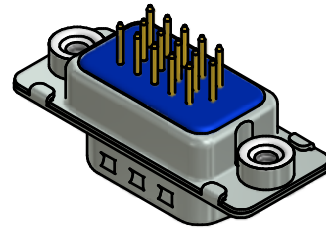

(5:1)

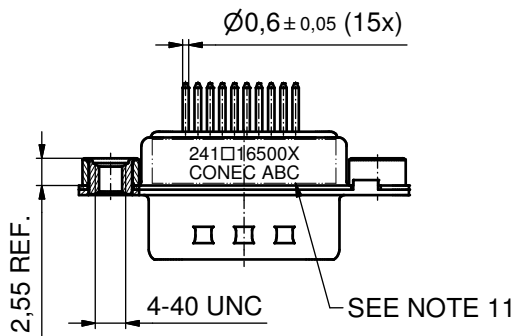
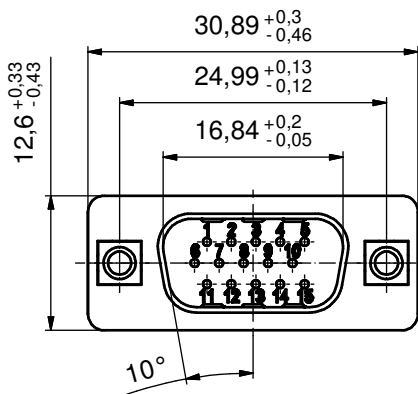
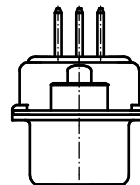
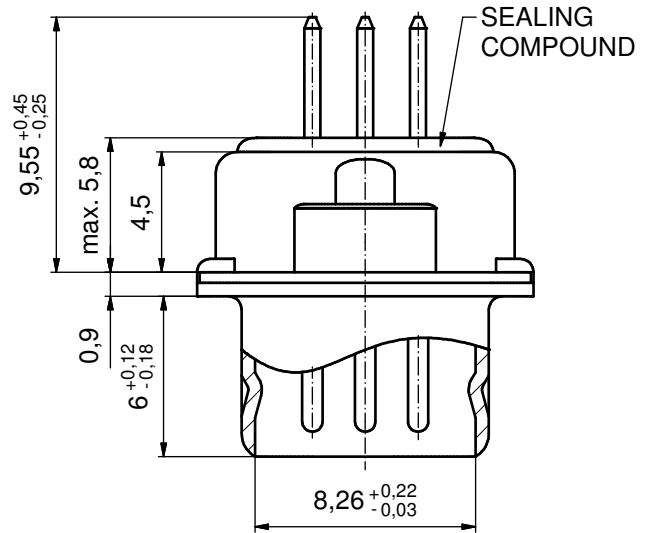

NOTES:

1. RoHS COMPLIANT
2. FOR WAVESOLDERING (SOLDER BATH TEMPERATURE 260°C FOR 5 SEC. AND SOLDER PREHEAT 100°C FOR 30 SEC.)
3. METALSHELLS: STEEL; min. 315µm TIN over 40-80µm NICKEL
4. INSULATORS: HIGH TEMPERATURE PLASTIC UL 94 V-0, BLACK
5. CONTACTS: COPPER ALLOY; PLATING (SEE PART NO.):  
 PLEASE ADD A for GOLD FLASH over NICKEL (PREFERRED TYPE)  
 PLEASE ADD B for 20µm HARD GOLD over min. 50µm NICKEL  
 PLEASE ADD C for 30µm HARD GOLD over min. 50µm NICKEL  
 CONTACTS TAILS PRETINNED
6. THREADED INSERTS: COPPER ALLOY; min. 200µm TIN over 80µm NICKEL
7. COLLARS: COPPER ALLOY; min 200µm TIN over 80µm NICKEL
8. DIELECTRIC WITHSTANDING VOLTAGE: 300 VDC
9. CAPACITANCE: 830pF ± 20%
10. MAXIMUM TORQUE VALUE FOR THREAD: 6 in. LB
11. CONNECTOR IS PART MARKED: 241□16500X CONEC ABC (see note 5)

Directive 2002/95/EC RoHS compliant

THIS DRAWING MAY NOT BE COPIED OR REPRODUCED IN ANY WAY, AND MAY NOT BE PASSED ON TO A THIRD PARTY WITHOUT WRITTEN PERMISSION. OWNERSHIP AND COPYRIGHT OF CONEC GmbH DO NOT ALTER CAD DRAWING BY HAND	tolerance		dim. in mm		scale: 2:1 (5:1)		
					material: SEE NOTES		
					title:		
					<b>D-SUB HD FILTER MALE</b> 15pos. SOLDER PIN STRAIGHT with threaded insert		
					dwg no:		
					24K1A1449 DIN-A3 sh: 1		
					part no: 241□16500X (see note 5)		
	rev.	description	date	name			
	a	Original					