

TS7441L - 30W CW GaN Broadband RF Switch SP4T

1.0 Features

- Low insertion loss: 0.40dB @ 800MHz
- High isolation: 36dB @ 800MHz
- High linear power handling capability
- No external DC blocking capacitors on RF lines
- Versatile 2.6-5.5V power supply

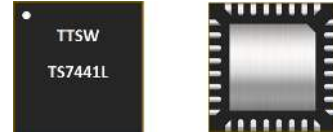

Figure 1 Device Image
(32 Pin 4x4x0.8mm QFN Package)

2.0 Applications

- Private mobile radio handsets
- Public safety handsets
- Cellular infrastructure
- Small cells
- LTE relays and microcells
- Satellite terminals



RoHS/REACH/Halogen Free Compliance

3.0 Description

The TS7441L is a symmetrical reflective Single Pole Four Throws (SP4T) switch designed for broadband, high power switching applications. Its broadband behavior from 1MHz to 2.7GHz frequencies makes the TS7441L an excellent switch for all the applications requiring low insertion loss, high isolation and high linearity within a small package size.

The TS7441L is packaged into a compact Quad Flat No lead (QFN) 4x4mm 32 leads plastic package.

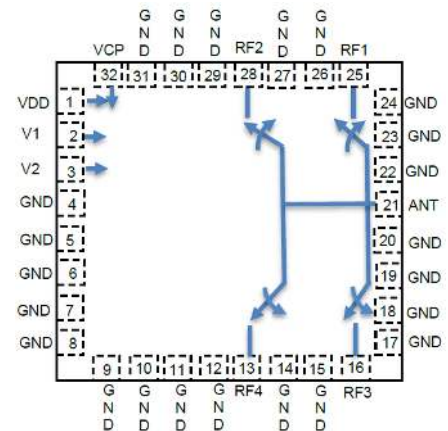

Figure 2 Function Block Diagram
(Top View)

4.0 Ordering Information

Table 1 Ordering Information

Base Part Number	Package Type	Form	Qty	Reel Diameter	Reel Width	Orderable Part Number
TS7441L	32 Pin 4x4x0.8mm QFN	Tape and Reel	3000	13" (330mm)	18mm	TS7441LMTRPBF
Evaluation Board						TS7441L-EVB

5.0 Pin Description

Table 2 Pin Definition

Pin Number	Pin Name	Description
1	VDD	DC power supply
2	V1	Switch control input 1
3	V2	Switch control input 2
4,5,6,7,8,9,10,11,12,14,15,17,18,19,20,22,23,24,26,27,29,30,31	NC	No internal connection, Can be grounded
13	RF4	RF port 4
16	RF3	RF port 3
21	ANT	Antenna port
28	RF2	RF port 2
25	RF1	RF port 1
32	VCP	Internal charge pump voltage output. Connect a 1nF capacitor to GND on this pin to improve switching time.

Note: The backside ground (thermal) pad of the package must be grounded directly to the ground plane of PCB with multiple vias to ensure proper operation and thermal management.

6.0 Absolute Maximum Ratings

Table 3 Absolute Maximum Ratings @T_A=+25°C Unless Otherwise Specified

Parameter	Symbol	Value	Unit
Electrical Ratings			
Power Supply Voltage	VDD	2.6 to 5.5	V
Storage Temperature Range	T _{st}	-55 to +125	°C
Operating Temperature Range	T _{op}	-40 to +85	°C
Maximum Junction Temperature	T _J	+140	°C
RF Input Power CW, 450MHz-1.5GHz, T _c = 85degC	RFx	45	dBm
RF Input Power CW, 2.5GHz (With Match), T _c = 85degC	RFx	43.5	dBm
RF Input Power CW, <450MHz	RFx	43.5	dBm
Thermal Ratings			
Thermal Resistance (junction-to-case) – Bottom side	R _{θJC}	15	°C/W
Thermal Resistance (junction-to-top)	R _{θJT}	≤ 37	°C/W
Soldering Temperature	T _{SOLD}	260	°C
ESD Ratings			
Human Body Model (HBM)	Level 1B	500 to <1000	V
Charged Device Model (CDM)	Level C3	≥1000	V
Moisture Rating			
Moisture Sensitivity Level	MSL	1	-

Attention:

Maximum ratings are absolute ratings. Exposure to absolute maximum rating conditions for extended periods may affect device reliability. Exceeding one or a combination of the absolute maximum ratings may cause permanent and irreversible damage to the device and/or to surrounding circuit.

7.0 Electrical Specifications

Table 4 Electrical Specifications @ $T_A=+25^{\circ}\text{C}$ Unless Otherwise Specified; $V_{DD}=+2.7\text{V}$; 50Ω Source/Load.

Parameter	Condition	Minimum	Typical	Maximum	Unit
Operating Frequency		1		2700	MHz
Insertion Loss, RFX	400MHz		0.35		dB
	800MHz		0.40	0.50	
	1.95GHz		0.70	0.80	
	2.5GHz		1.00	1.10	
	2.5GHz (With Match) See page 5,7		0.70		
Isolation, ANT-RFX	400MHz		43		dB
	800MHz	33	36		
	1.95GHz	23	26		
	2.5GHz	21	23		
	2.5GHz (With Match) See page 5,7		23		
Return Loss, ANT-RFX	400MHz		28		dB
	800MHz		23		
	1.95GHz		14		
	2.5GHz		11		
	2.5GHz (With Match) See page 5,7		15		
H2	800MHz, Pin=40dBm		-75		dBc
H3	800MHz, Pin=40dBm		-80		dBc
IIP3	800MHz		70		dBm
P0.1dB ^[1]	450MHz - 2.5GHz, CW		45		dBm
P0.1dB ^[1]	20MHz - 450MHz, CW		43		dBm
P0.1dB ^[1]	<20MHz, CW		42		dBm
Switching time	50% ctrl to 10/90% of the RF value is settled. C1=1nF (refer to Figure 3)		2.0		μs
Control Voltage	Power supply VDD	2.6	3.3	5.5	V
	All control pins high, V_{ih}	1.0	3.3	5.25	V
	All control pins low, V_{il}	-0.3		0.5	V
Control Current	All control pins low, I_{il}		0		μA
	All control pins high, I_{ih}			7.5	μA
Current Consumption, IDD	Active mode		160	200	μA

Note: [1] P0.1dB is a figure of merit.

[2] No external DC blocking capacitors required on RF pins unless DC voltage is applied on a RF pin.

[3] Insertion loss goes up by 0.1dB at 85degC base plate temp.

8.0 Switch Truth Table

Table 5 Switch Truth Table

V1	V2	Active RF Path
0	0	ANT-RF1
1	0	ANT-RF2
0	1	ANT-RF3
1	1	ANT-RF4

Attention: [1] VDD should be applied first before V1 and V2, otherwise may cause damage to the device.
 [2] There is an internal pull-down to ground on V1 and V2 control pins, therefore the switch state at start-up without any control voltage applied will be ANT-RF1 on by default.

9.0 Evaluation Board Schematic (No match)

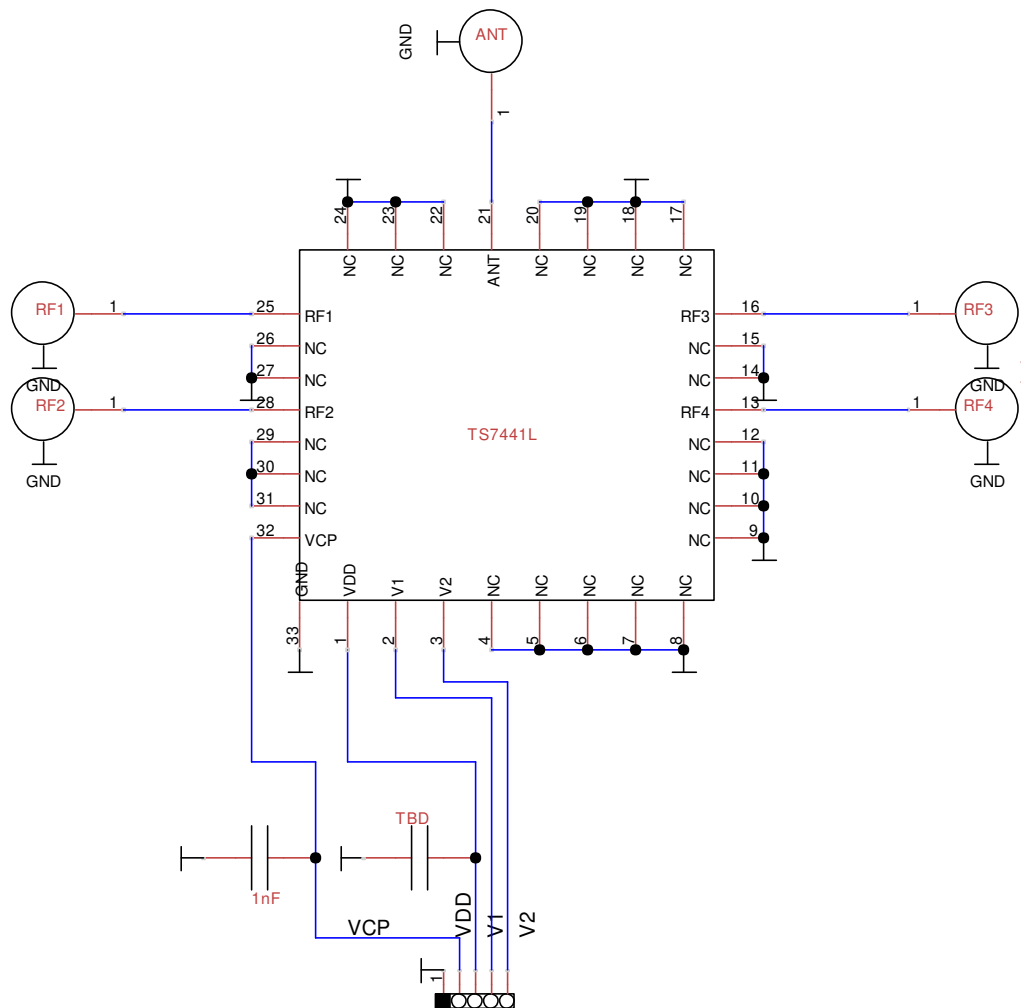

Figure 3 Evaluation Board Schematic (No Match)

10.0 Evaluation Board Schematic (With match)

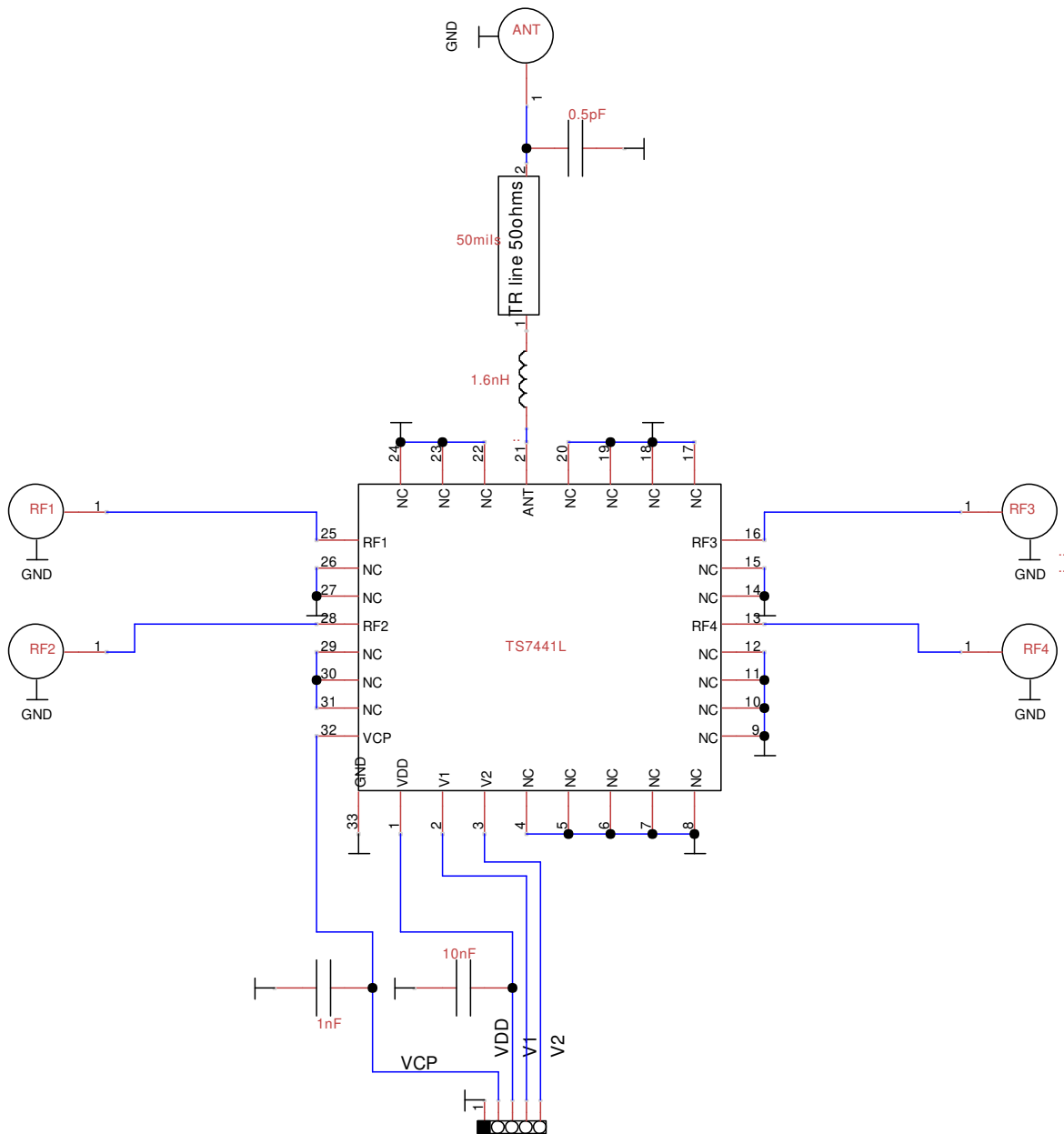

Figure 4 Evaluation Board Schematic (With Match)

Value	Part #	Manufacturer
1.6nH	0603HC-1N6XJEW	Coilcraft
0.5pF	0402N0R5AW251	Passive Plus Inc

11.0 Typical Characteristics (No match)

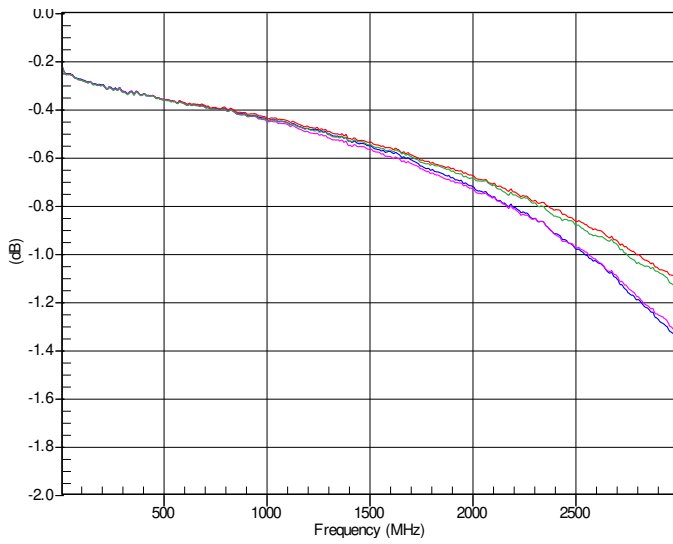

Figure 5 RF1 to RF4 Insertion Loss

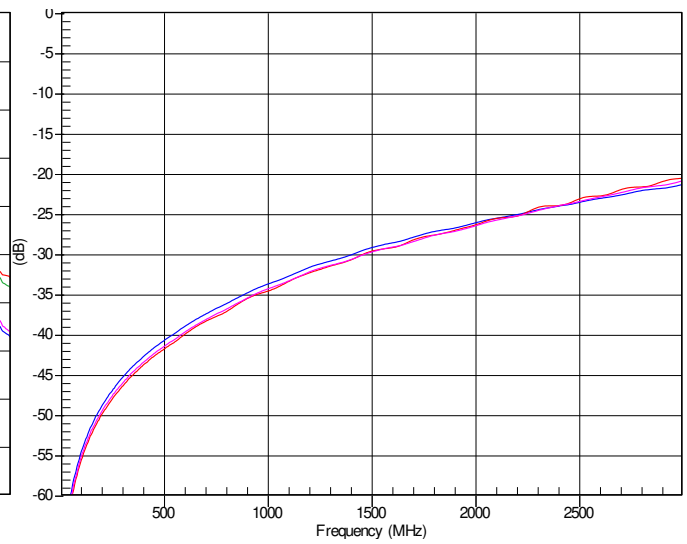

Figure 6 RF1 on, RF2 to RF4 Isolation

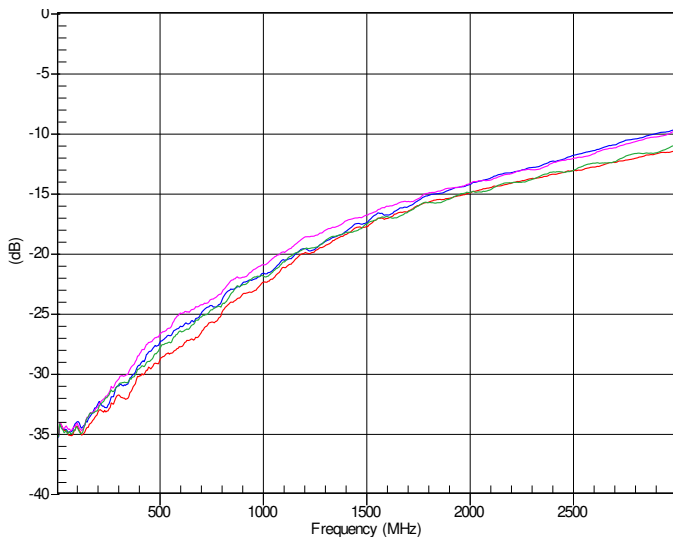

Figure 7 RF1 to RF4 Return Loss

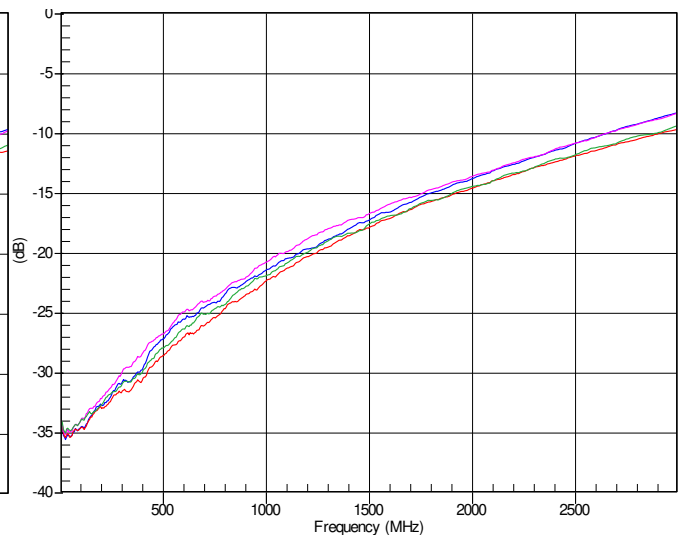

Figure 8 ANT Return Loss

12.0 Typical Characteristics (With match)

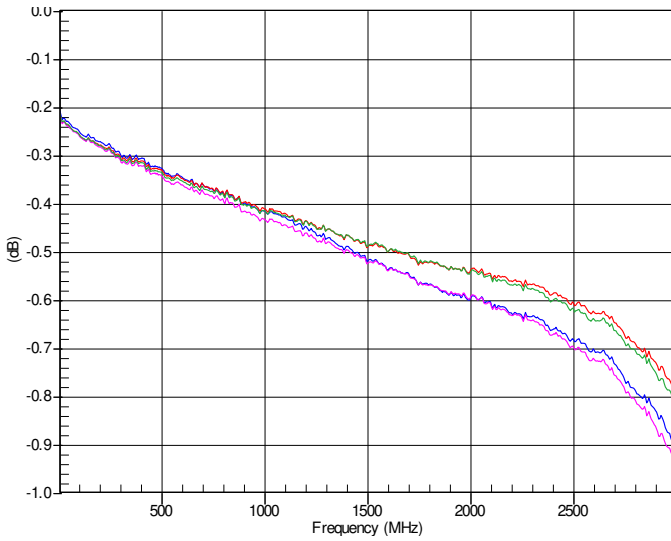

Figure 9 RF1 to RF4 Insertion Loss

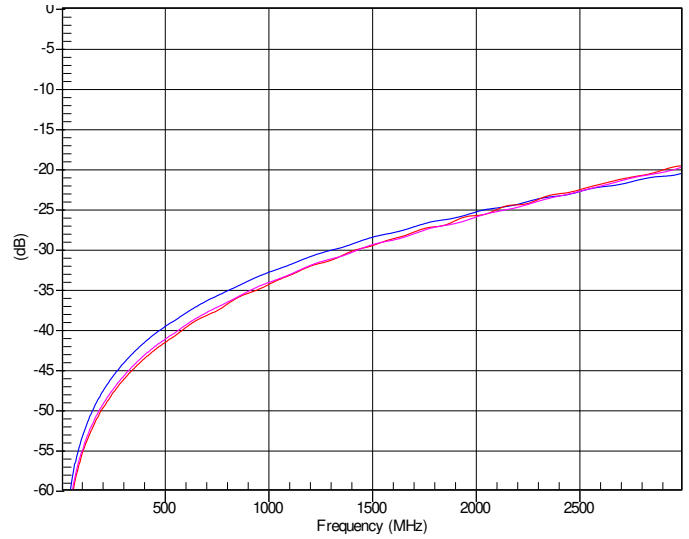

Figure 10 RF1 on, RF2 to RF4 Isolation

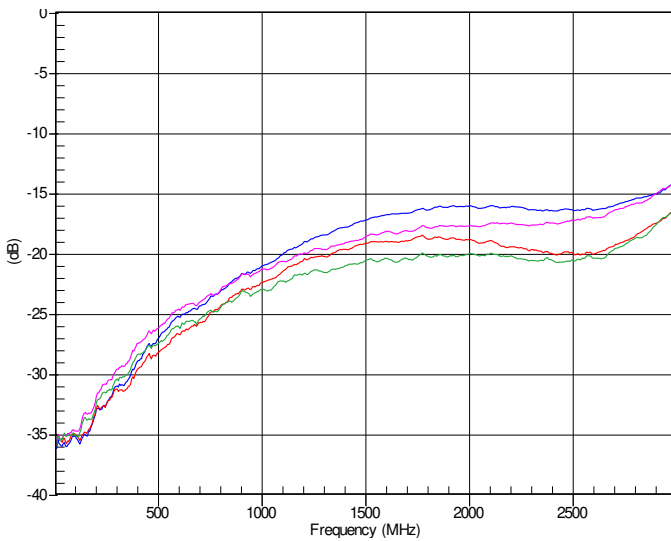

Figure 11 RF1 to RF4 Return Loss

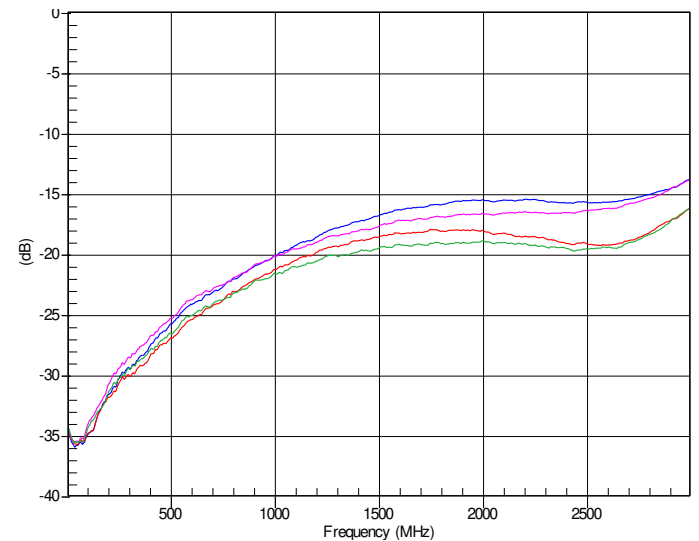

Figure 12 ANT Return Loss

13.0 Device Package Information

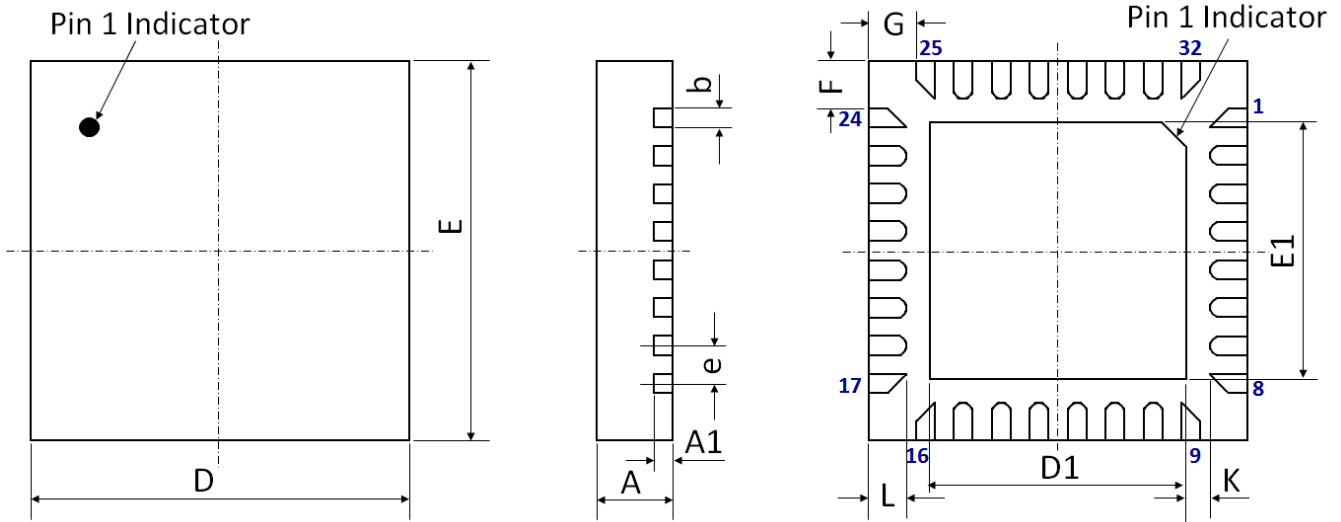

Figure 13 Device Package Drawing
(All dimensions are in mm)

Table 6 Device Package Dimensions

Dimension (mm)	Value (mm)	Tolerance (mm)	Dimension (mm)	Value (mm)	Tolerance (mm)
A	0.80	±0.05	E	4.00 BSC	±0.05
A1	0.203	±0.02	E1	2.70	±0.05
b	0.20	+0.05/-0.07	F	0.50	±0.05
D	4.00 BSC	±0.05	G	0.50	±0.05
D1	2.70	±0.05	L	0.40	±0.05
e	0.40 BSC	±0.05	K	0.25	±0.05

Note: Lead finish: Pure Sn without underlayer; Thickness: 7.5µm ~ 20µm (Typical 10µm ~ 12µm)

Attention:

Please refer to application notes [TN-001](#) and [TN-002](#) at <http://www.tagoretech.com> for PCB and soldering related guidelines.

14.0 PCB Land Design

Guidelines:

- [1] 4 layer PCB is recommended.
- [2] Via diameter is recommended to be 0.2mm to prevent solder wicking inside the vias.
- [3] Thermal vias shall only be placed on the center pad.
- [4] The maximum via number for the center pad is $4(X) \times 4(Y) = 16$.

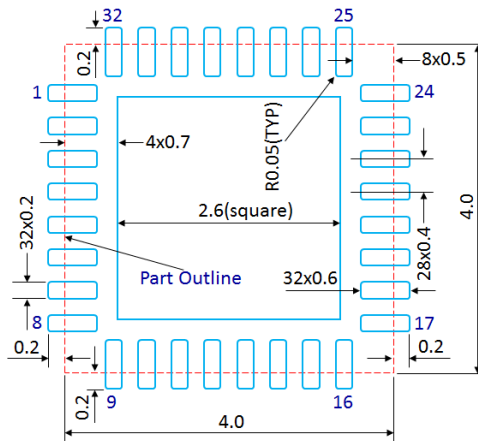

Figure 14 PCB Land Pattern
(Dimensions are in mm)

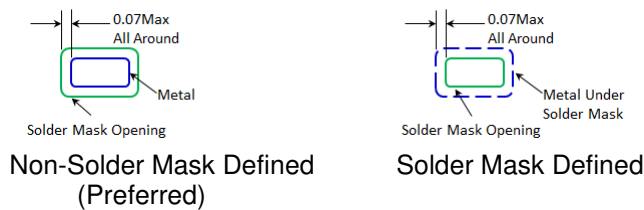

Figure 15 Solder Mask Pattern
(Dimensions are in mm)

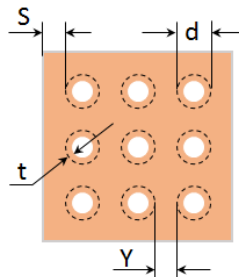

Figure 16 Thermal Via Pattern

(Recommended Values: $S \geq 0.15\text{mm}$; $Y \geq 0.20\text{mm}$; $d = 0.2\text{mm}$; Plating Thickness $t = 25\mu\text{m}$ or $50\mu\text{m}$)

15.0 PCB Stencil Design

Guidelines:

[1] Laser-cut, stainless steel stencil is recommended with electro-polished trapezoidal walls to improve the paste release.

[2] Stencil thickness is recommended to be 125 μ m.

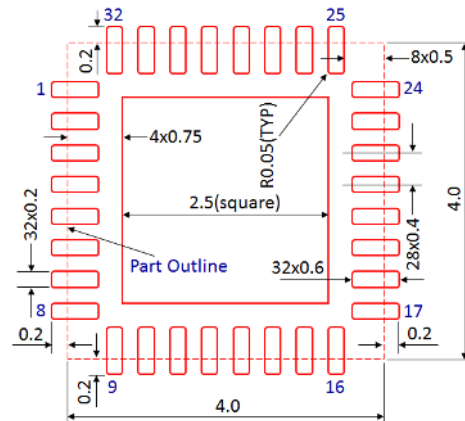

Figure 17 Stencil Openings
(Dimensions are in mm)

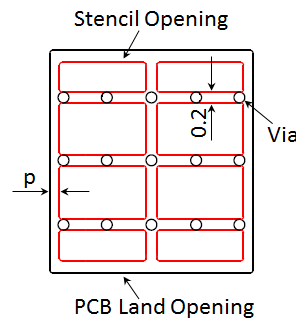

Figure 18 Stencil Openings Shall not Cover Via Areas If Possible
(Dimensions are in mm)

16.0 Tape and Reel Information

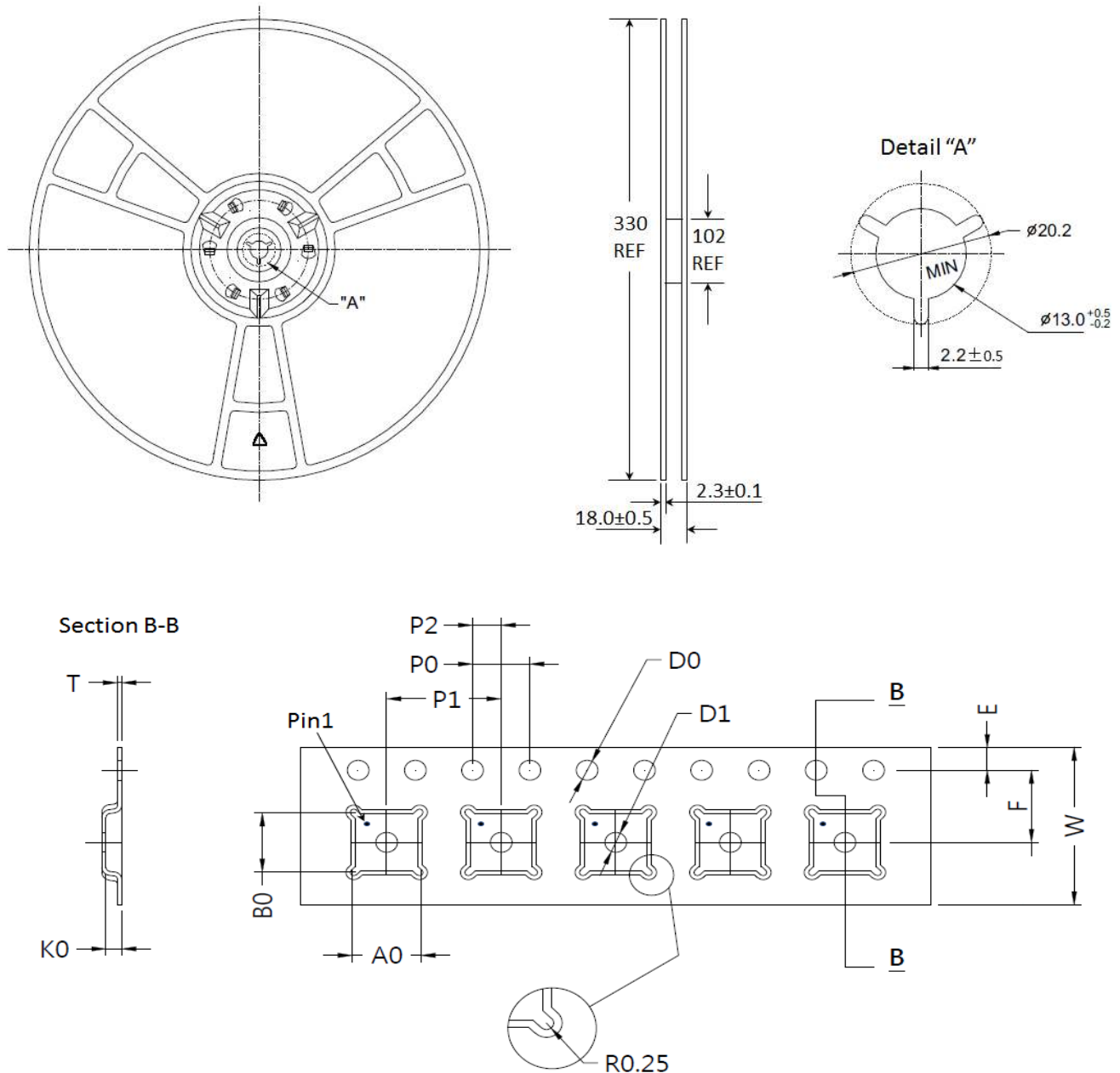

Figure 19 Tape and Reel Drawing

Table 7 Tape and Reel Dimensions

Dimension (mm)	Value (mm)	Tolerance (mm)	Dimension (mm)	Value (mm)	Tolerance (mm)
A0	4.35	±0.10	K0	1.10	±0.10
B0	4.35	±0.10	P0	4.00	±0.10
D0	1.50	+0.10/-0.00	P1	8.00	±0.10
D1	1.50	+0.10/-0.00	P2	2.00	±0.05
E	1.75	±0.10	T	0.30	±0.05
F	5.50	±0.05	W	12.00	±0.30

Edition Revision 2.1 - 2019-11-25

Published by

Tagore Technology Inc.
5 East College Drive, Suite 200
Arlington Heights, IL 60004, USA

©2018 All Rights Reserved

Legal Disclaimer

The information provided in this document shall in no event be regarded as a guarantee of conditions or characteristics. Tagore Technology assumes no responsibility for the consequences of the use of this information, nor for any infringement of patents or of other rights of third parties which may result from the use of this information. No license is granted by implication or otherwise under any patent or patent rights of Tagore Technology. The specifications mentioned in this document are subject to change without notice.

Information

For further information on technology, delivery terms and conditions and prices, please contact Tagore Technology: support@tagoretech.com.