



PCF2127

Accurate RTC with integrated quartz crystal for industrial applications

Rev. 8 — 19 December 2014

Product data sheet

1. General description

The PCF2127 is a CMOS¹ Real Time Clock (RTC) and calendar with an integrated Temperature Compensated Crystal (Xtal) Oscillator (TCXO) and a 32.768 kHz quartz crystal optimized for very high accuracy and very low power consumption. The PCF2127 has 512 bytes of general-purpose static RAM, a selectable I²C-bus or SPI-bus, a backup battery switch-over circuit, a programmable watchdog function, a timestamp function, and many other features.

For a selection of NXP Real-Time Clocks, see [Table 94 on page 89](#)

2. Features and benefits

- UL Recognized Component
- Operating temperature range from $-40\text{ }^{\circ}\text{C}$ to $+85\text{ }^{\circ}\text{C}$
- Temperature Compensated Crystal Oscillator (TCXO) with integrated capacitors
- Typical accuracy:
 - ◆ PCF2127AT: ± 3 ppm from $-15\text{ }^{\circ}\text{C}$ to $+60\text{ }^{\circ}\text{C}$
 - ◆ PCF2127T: ± 3 ppm from $-30\text{ }^{\circ}\text{C}$ to $+80\text{ }^{\circ}\text{C}$
- Integration of a 32.768 kHz quartz crystal and oscillator in the same package
- Provides year, month, day, weekday, hours, minutes, seconds, and leap year correction
- 512 bytes of general-purpose static RAM
- Timestamp function
 - ◆ with interrupt capability
 - ◆ detection of two different events on one multilevel input pin (for example, for tamper detection)
- Two line bidirectional 400 kHz Fast-mode I²C-bus interface
- 3 line SPI-bus with separate data input and output (maximum speed 6.5 Mbit/s)
- Battery backup input pin and switch-over circuitry
- Battery backed output voltage
- Battery low detection function
- Extra power fail detection function with input and output pins
- Power-On Reset Override (PORO)
- Oscillator stop detection function
- Interrupt output (open-drain)

1. The definition of the abbreviations and acronyms used in this data sheet can be found in [Section 21](#).



- Programmable 1 second or 1 minute interrupt
- Programmable watchdog timer with interrupt
- Programmable alarm function with interrupt capability
- Programmable square wave output pin
- Programmable countdown timer with interrupt
- Clock operating voltage: 1.8 V to 4.2 V
- Low supply current: typical 0.70 μ A at $V_{DD} = 3.3$ V

3. Applications

- Electronic metering for electricity, water, and gas
- Precision timekeeping
- Access to accurate time of the day
- GPS equipment to reduce time to first fix
- Applications that require an accurate process timing
- Products with long automated unattended operation time

4. Ordering information

Table 1. Ordering information

Type number	Package		
	Name	Description	Version
PCF2127AT	SO20	plastic small outline package; 20 leads; body width 7.5 mm	SOT163-1
PCF2127T	SO16	plastic small outline package; 16 leads; body width 7.5 mm	SOT162-1

4.1 Ordering options

Table 2. Ordering options

Product type number	Orderable part number	Sales item (12NC)	Delivery form	IC revision
PCF2127AT/2	PCF2127AT/2Y	935299867518	tape and reel, 13 inch, dry pack	2
PCF2127T/2	PCF2127T/2Y	935299866518	tape and reel, 13 inch, dry pack	2

5. Marking

Table 3. Marking codes

Product type number	Marking code
PCF2127AT/2	PCF2127AT
PCF2127T/2	PCF2127T

6. Block diagram

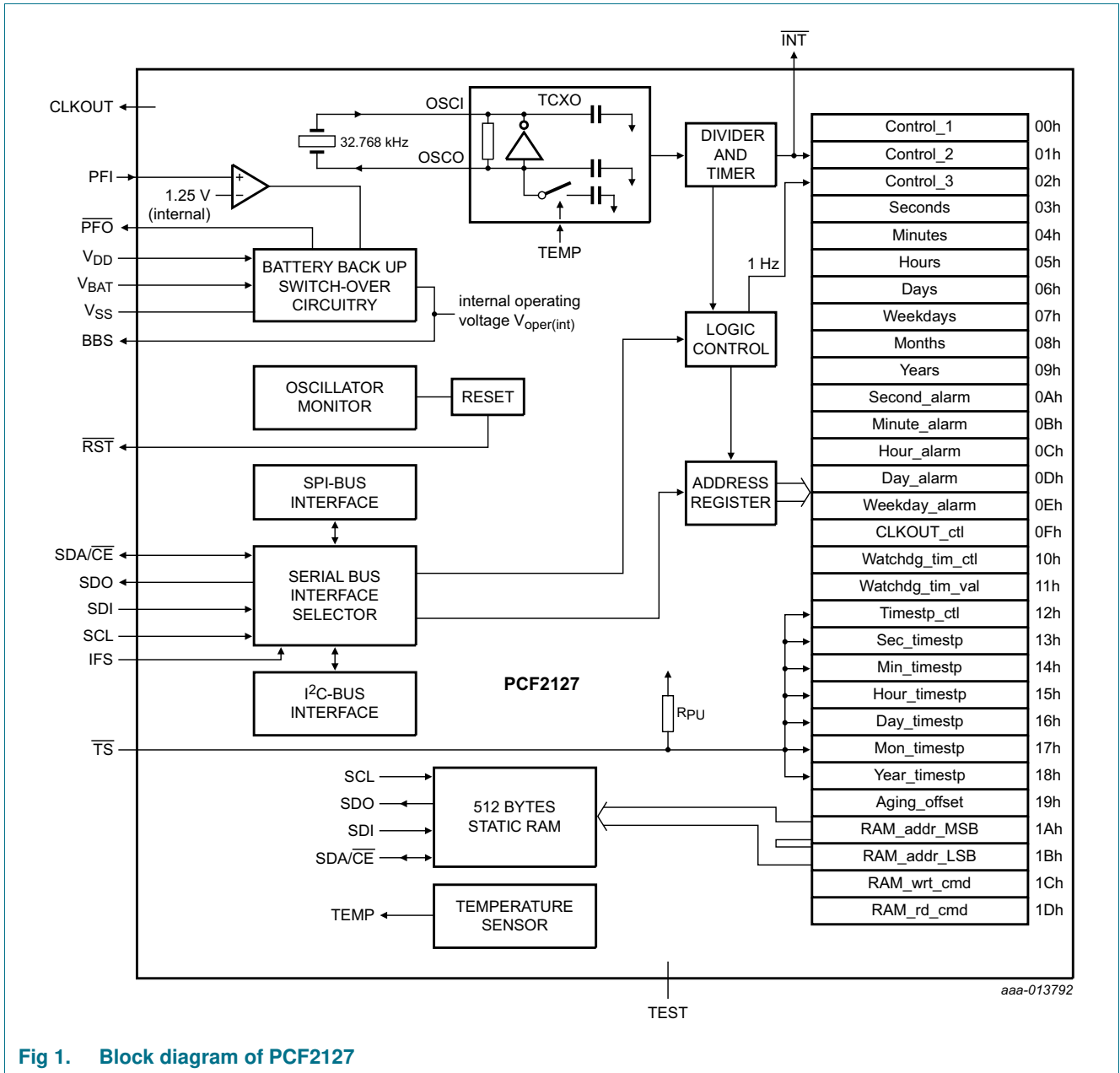
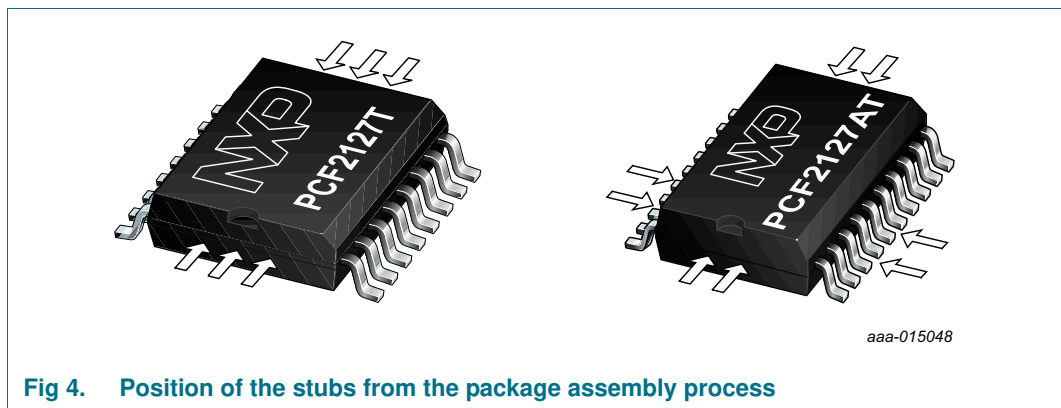
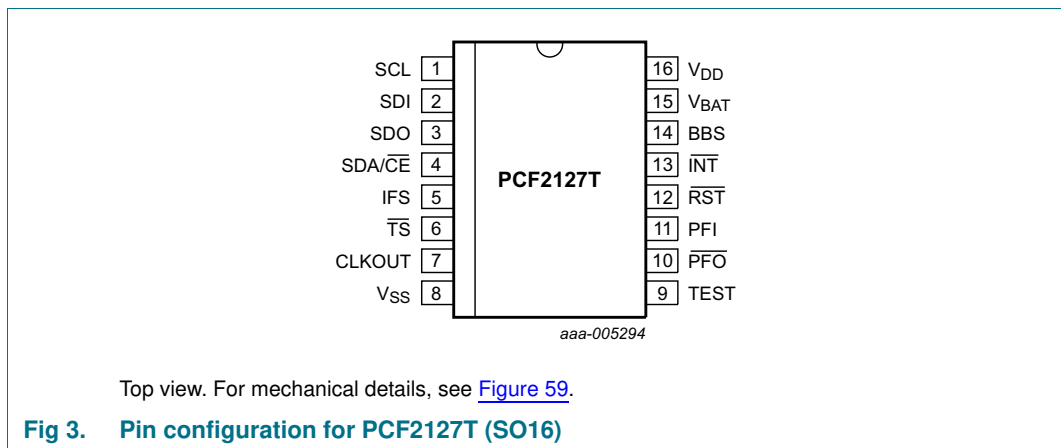
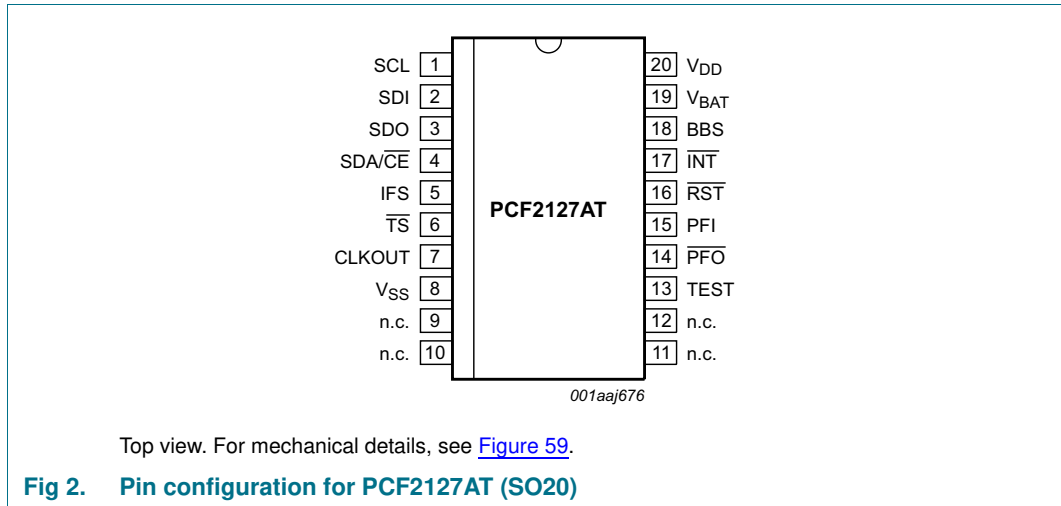

Fig 1. Block diagram of PCF2127

7. Pinning information

7.1 Pinning



After lead forming and cutting, there remain stubs from the package assembly process. These stubs are present at the edge of the package as illustrated in [Figure 4](#). The stubs are at an electrical potential. To avoid malfunction of the PCF2127, it has to be ensured that they are not shorted with another electrical potential (e.g. by condensation).

7.2 Pin description

Table 4. Pin description of PCF2127

Input or input/output pins must always be at a defined level (V_{SS} or V_{DD}) unless otherwise specified.

Symbol	Pin		Description
	PCF2127AT	PCF2127T	
SCL	1	1	combined serial clock input for both I ² C-bus and SPI-bus
SDI	2	2	serial data input for SPI-bus connect to pin V_{SS} if I ² C-bus is selected
SDO	3	3	serial data output for SPI-bus, push-pull
SDA/ \overline{CE}	4	4	combined serial data input and output for the I ² C-bus and chip enable input (active LOW) for the SPI-bus
IFS	5	5	interface selector input connect to pin V_{SS} to select the SPI-bus connect to pin BBS to select the I ² C-bus
\overline{TS}	6	6	timestamp input (active LOW) with 200 k Ω internal pull-up resistor (R_{PU})
CLKOUT	7	7	clock output (open-drain)
V_{SS}	8	8	ground supply voltage
n.c.	9 to 12	-	not connected; do not connect; do not use as feed through
TEST	13	9	do not connect; do not use as feed through
\overline{PFO}	14	10	power fail output (open-drain; active LOW)
PFI	15	11	power fail input
\overline{RST}	16	12	reset output (open-drain; active LOW)
\overline{INT}	17	13	interrupt output (open-drain; active LOW)
BBS	18	14	output voltage (battery backed)
V_{BAT}	19	15	battery supply voltage (backup) connect to V_{SS} if battery switch-over is not used
V_{DD}	20	16	supply voltage

8. Functional description

The PCF2127 is a Real Time Clock (RTC) and calendar with an on-chip Temperature Compensated Crystal (Xtal) Oscillator (TCXO) and a 32.768 kHz quartz crystal integrated into the same package (see [Section 8.3.3](#)).

Address and data are transferred by a selectable 400 kHz Fast-mode I²C-bus or a 3 line SPI-bus with separate data input and output (see [Section 9](#)). The maximum speed of the SPI-bus is 6.5 Mbit/s.

The PCF2127 has a backup battery input pin and backup battery switch-over circuit which monitors the main power supply. The backup battery switch-over circuit automatically switches to the backup battery when a power failure condition is detected (see [Section 8.6.1](#)). Accurate timekeeping is maintained even when the main power supply is interrupted.

A battery low detection circuit monitors the status of the battery (see [Section 8.6.2](#)). When the battery voltage drops below a certain threshold value, a flag is set to indicate that the battery must be replaced soon. This ensures the integrity of the data during periods of battery backup.

8.1 Register overview

The PCF2127 contains an auto-incrementing address register: the built-in address register will increment automatically after each read or write of a data byte up to the register 1Bh. After register 1Bh, the auto-incrementing will wrap around to address 00h (see [Figure 5](#)).

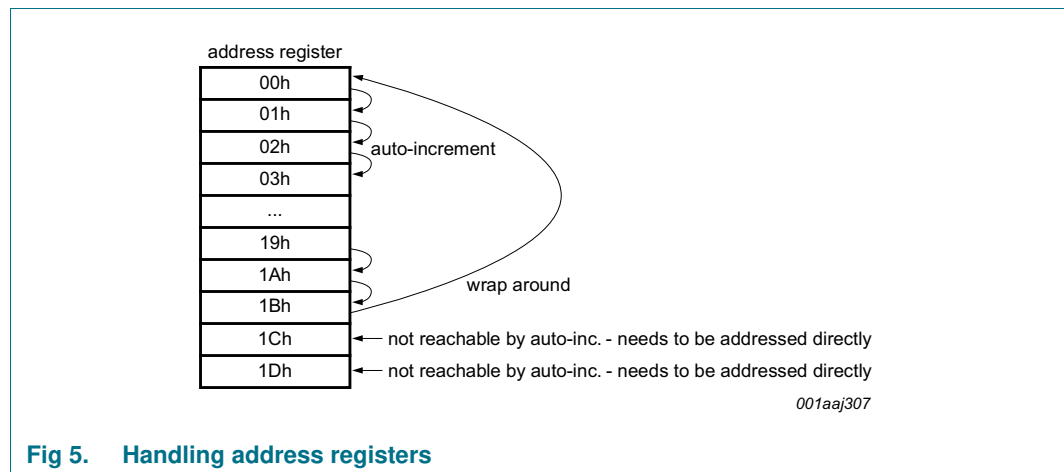

Fig 5. Handling address registers

- The first three registers (memory address 00h, 01h, and 02h) are used as control registers (see [Section 8.2](#)).
- The memory addresses 03h through to 09h are used as counters for the clock function (seconds up to years). The date is automatically adjusted for months with fewer than 31 days, including corrections for leap years. The clock can operate in 12-hour mode with an AM/PM indication or in 24-hour mode (see [Section 8.9](#)).
- The registers at addresses 0Ah through 0Eh define the alarm function. It can be selected that an interrupt is generated when an alarm event occurs (see [Section 8.10](#)).

- The register at address 0Fh defines the temperature measurement period and the clock out mode. The temperature measurement can be selected from every 4 minutes (default) down to every 30 seconds (see [Table 14](#)). CLKOUT frequencies of 32.768 kHz (default) down to 1 Hz for use as system clock, microcontroller clock, and so on, can be chosen (see [Table 15](#)).
- The registers at addresses 10h and 11h are used for the watchdog and countdown timer functions. The watchdog timer has four selectable source clocks allowing for timer periods from less than 1 ms to greater than 4 hours (see [Table 58](#)). Either the watchdog timer **or** the countdown timer can be enabled (see [Section 8.11](#)). For the watchdog timer, it is possible to select whether an interrupt or a pulse on the reset pin is generated when the watchdog times out. For the countdown timer, it is only possible that an interrupt is generated at the end of the countdown.
- The registers at addresses 12h to 18h are used for the timestamp function. When the trigger event happens, the actual time is saved in the timestamp registers (see [Section 8.12](#)).
- The register at address 19h is used for the correction of the crystal aging effect (see [Section 8.4.1](#)).
- The registers at addresses 1Ah and 1Bh define the RAM address. The register at address 1Ch (RAM_wrt_cmd) is the RAM write command; register 1Dh (RAM_rd_cmd) is the RAM read command. Data is transferred to or from the RAM by the serial interface (see [Section 8.5](#)).
- The registers Seconds, Minutes, Hours, Days, Months, and Years are all coded in Binary Coded Decimal (BCD) format to simplify application use. Other registers are either bit-wise or standard binary.

When one of the RTC registers is written or read, the content of all counters is temporarily frozen. This prevents a faulty writing or reading of the clock and calendar during a carry condition (see [Section 8.9.8](#)).

Table 5. Register overview

Bit positions labeled as - are not implemented and return 0 when read. Bits labeled as T must always be written with logic 0. Bits labeled as X are undefined at power-on and unchanged by subsequent resets.

Address	Register name	Bit								Reset value	Reference
		7	6	5	4	3	2	1	0		
Control registers											
00h	Control_1	EXT_TEST	T	STOP	TSF1	POR_OVRD	12_24	MI	SI	0000 1000	Table 7 on page 10
01h	Control_2	MSF	WDTF	TSF2	AF	CDTF	TSIE	AIE	CDTIE	0000 0000	Table 9 on page 11
02h	Control_3	PWRMNG[2:0]			BTSE	BF	BLF	BIE	BLIE	0000 0000	Table 11 on page 12
Time and date registers											
03h	Seconds	OSF	SECONDS (0 to 59)						1XXX XXXX	Table 28 on page 30	
04h	Minutes	-	MINUTES (0 to 59)						- XXX XXXX	Table 31 on page 31	
05h	Hours	-	-	AMPM	HOURS (1 to 12) in 12-hour mode			- - XX XXXX	Table 33 on page 32		
				HOURS (0 to 23) in 24-hour mode			- - XX XXXX				
06h	Days	-	-	DAYS (1 to 31)				- - XX XXXX	Table 35 on page 32		
07h	Weekdays	-	-	-	-	-	WEEKDAYS (0 to 6)		- - - - XXX	Table 37 on page 33	
08h	Months	-	-	MONTHS (1 to 12)				- - - X XXXX	Table 40 on page 34		
09h	Years	YEARS (0 to 99)						XXXX XXXX	Table 43 on page 35		
Alarm registers											
0Ah	Second_alarm	AE_S	SECOND_ALARM (0 to 59)						1XXX XXXX	Table 45 on page 38	
0Bh	Minute_alarm	AE_M	MINUTE_ALARM (0 to 59)						1XXX XXXX	Table 47 on page 38	
0Ch	Hour_alarm	AE_H	-	AMPM	HOUR_ALARM (1 to 12) in 12-hour mode			1 - XX XXXX	Table 49 on page 39		
				HOUR_ALARM (0 to 23) in 24-hour mode			1 - XX XXXX				
0Dh	Day_alarm	AE_D	-	DAY_ALARM (1 to 31)				1 - XX XXXX	Table 51 on page 39		
0Eh	Weekday_alarm	AE_W	-	-	-	-	WEEKDAY_ALARM (0 to 6)		1 - - - - XXX	Table 53 on page 40	
CLKOUT control register											
0Fh	CLKOUT_ctl	TCR[1:0]		OTPR	-	-	COF[2:0]		00X - - 000	Table 13 on page 12	
watchdog registers											
10h	Watchdg_tim_ctl	WD_CD[1:0]	TI_TP	-	-	-	TF[1:0]		000 - - - 11	Table 55 on page 41	
11h	Watchdg_tim_val	WATCHDGD_TIM_VAL[7:0]						XXXX XXXX	Table 57 on page 42		
Timestamp registers											
12h	Timestamp_ctl	TSM	TSOFF	-	1_O_16_TIMESTP[4:0]			00 - X XXXX	Table 68 on page 50		

Table 5. Register overview ...continued

Bit positions labeled as - are not implemented and return 0 when read. Bits labeled as T must always be written with logic 0. Bits labeled as X are undefined at power-on and unchanged by subsequent resets.

Address	Register name	Bit								Reset value	Reference	
		7	6	5	4	3	2	1	0			
13h	Sec_timestp	-	SECOND_TIMESTP (0 to 59)								- XXX XXXX	Table 70 on page 50
14h	Min_timestp	-	MINUTE_TIMESTP (0 to 59)								- XXX XXXX	Table 72 on page 51
15h	Hour_timestp	-	-	AMPM	HOUR_TIMESTP (1 to 12) in 12-hour mode					- - XX XXXX	Table 74 on page 51	
				HOUR_TIMESTP (0 to 23) in 24-hour mode								
16h	Day_timestp	-	-	DAY_TIMESTP (1 to 31)						- - XX XXXX	Table 76 on page 52	
17h	Mon_timestp	-	-	-	MONTH_TIMESTP (1 to 12)				- - - X XXXX	Table 78 on page 52		
18h	Year_timestp	YEAR_TIMESTP (0 to 99)								XXXX XXXX	Table 80 on page 52	
Aging offset register												
19h	Aging_offset	-	-	-	-	AO[3:0]			- - - - 1000	Table 17 on page 14		
RAM registers												
1Ah	RAM_addr_MSB	-	-	-	-	-	-	-	RA8	- - - - - 0	Table 20 on page 16	
1Bh	RAM_addr_LSB	RA[7:0]								0000 0000	Table 22 on page 16	
1Ch	RAM_wrt_cmd	X	X	X	X	X	X	X	X	XXXX XXXX	Table 23 on page 16	
1Dh	RAM_rd_cmd	X	X	X	X	X	X	X	X	XXXX XXXX	Table 24 on page 16	

8.2 Control registers

The first 3 registers of the PCF2127, with the addresses 00h, 01h, and 02h, are used as control registers.

8.2.1 Register Control_1

Table 6. Control_1 - control and status register 1 (address 00h) bit allocation

Bits labeled as T must always be written with logic 0.

Bit	7	6	5	4	3	2	1	0
Symbol	EXT_TEST	T	STOP	TSF1	POR_OVRD	12_24	MI	SI
Reset value	0	0	0	0	1	0	0	0

Table 7. Control_1 - control and status register 1 (address 00h) bit description

Bits labeled as T must always be written with logic 0.

Bit	Symbol	Value	Description	Reference
7	EXT_TEST	0	normal mode	Section 8.14
		1	external clock test mode	
6	T	0	unused	-
5	STOP	0	RTC source clock runs	Section 8.15
		1	RTC clock is stopped; RTC divider chain flip-flops are asynchronously set logic 0; CLKOUT at 32.768 kHz, 16.384 kHz, or 8.192 kHz is still available	
4	TSF1	0	no timestamp interrupt generated	Section 8.12.1
		1	flag set when \overline{TS} input is driven to an intermediate level between power supply and ground; flag must be cleared to clear interrupt	
3	POR_OVRD	0	Power-On Reset Override (PORO) facility disabled; set logic 0 for normal operation	Section 8.8.2
		1	Power-On Reset Override (PORO) sequence reception enabled	
2	12_24	0	24-hour mode selected	Table 33, Table 49, Table 74
		1	12-hour mode selected	
1	MI	0	minute interrupt disabled	Section 8.13.1
		1	minute interrupt enabled	
0	SI	0	second interrupt disabled	
		1	second interrupt enabled	

8.2.2 Register Control_2

Table 8. Control_2 - control and status register 2 (address 01h) bit allocation

Bit	7	6	5	4	3	2	1	0
Symbol	MSF	WDTF	TSF2	AF	CDTF	TSIE	AIE	CDTIE
Reset value	0	0	0	0	0	0	0	0

Table 9. Control_2 - control and status register 2 (address 01h) bit description

Bit	Symbol	Value	Description	Reference
7	MSF	0	no minute or second interrupt generated	Section 8.13
		1	flag set when minute or second interrupt generated; flag must be cleared to clear interrupt	
6	WDTF	0	no watchdog timer interrupt or reset generated	Section 8.13.4
		1	flag set when watchdog timer interrupt or reset generated; flag cannot be cleared by command (read-only)	
5	TSF2	0	no timestamp interrupt generated	Section 8.12.1
		1	flag set when $\overline{\text{TS}}$ input is driven to ground; flag must be cleared to clear interrupt	
4	AF	0	no alarm interrupt generated	Section 8.10.6
		1	flag set when alarm triggered; flag must be cleared to clear interrupt	
3	CDTF	0	no countdown timer interrupt generated	Section 8.11.4
		1	flag set when countdown timer interrupt generated; flag must be cleared to clear interrupt	
2	TSIE	0	no interrupt generated from timestamp flag	Section 8.13.6
		1	interrupt generated when timestamp flag set	
1	AIE	0	no interrupt generated from the alarm flag	Section 8.13.5
		1	interrupt generated when alarm flag set	
0	CDTIE	0	no interrupt generated from countdown timer flag	Section 8.13.2
		1	interrupt generated when countdown timer flag set	

8.2.3 Register Control_3

Table 10. Control_3 - control and status register 3 (address 02h) bit allocation

Bit	7	6	5	4	3	2	1	0
Symbol	PWRMNG[2:0]			BTSE	BF	BLF	BIE	BLIE
Reset value	0	0	0	0	0	0	0	0

Table 11. Control_3 - control and status register 3 (address 02h) bit description

Bit	Symbol	Value	Description	Reference
7 to 5	PWRMNG[2:0]	see Table 25	control of the battery switch-over, battery low detection, and extra power fail detection functions	Section 8.6
4	BTSE	0	no timestamp when battery switch-over occurs	Section 8.12.4
		1	time-stamped when battery switch-over occurs	
3	BF	0	no battery switch-over interrupt generated	Section 8.6.1 and Section 8.12.4
		1	flag set when battery switch-over occurs; flag must be cleared to clear interrupt	
2	BLF	0	battery status ok; no battery low interrupt generated	Section 8.6.2
		1	battery status low; flag cannot be cleared by command	
1	BIE	0	no interrupt generated from the battery flag (BF)	Section 8.13.7
		1	interrupt generated when BF is set	
0	BLIE	0	no interrupt generated from battery low flag (BLF)	Section 8.13.8
		1	interrupt generated when BLF is set	

8.3 Register CLKOUT_ctl

Table 12. CLKOUT_ctl - CLKOUT control register (address 0Fh) bit allocation

Bit positions labeled as - are not implemented and return 0 when read. Bits labeled as X are undefined at power-on and unchanged by subsequent resets.

Bit	7	6	5	4	3	2	1	0
Symbol	TCR[1:0]		OTPR	-	-	COF[2:0]		
Reset value	0	0	X	-	-	0	0	0

Table 13. CLKOUT_ctl - CLKOUT control register (address 0Fh) bit description

Bit positions labeled as - are not implemented and return 0 when read. Bits labeled as X are undefined at power-on and unchanged by subsequent resets.

Bit	Symbol	Value	Description
7 to 6	TCR[1:0]	see Table 14	temperature measurement period
5	OTPR	0	no OTP refresh
		1	OTP refresh performed
4 to 3	-	-	unused
2 to 0	COF[2:0]	see Table 15	CLKOUT frequency selection

8.3.1 Temperature compensated crystal oscillator

The frequency of tuning fork quartz crystal oscillators is temperature-dependent. In the PCF2127, the frequency deviation caused by temperature variation is corrected by adjusting the load capacitance of the crystal oscillator.

The load capacitance is changed by switching between two load capacitance values using a modulation signal with a programmable duty cycle. In order to compensate the spread of the quartz parameters every chip is factory calibrated.

The frequency accuracy can be evaluated by measuring the frequency of the square wave signal available at the output pin CLKOUT. However, the selection of $f_{CLKOUT} = 32.768$ kHz (default value) leads to inaccurate measurements. Accurate frequency measurement occurs when $f_{CLKOUT} = 16.384$ kHz or lower is selected (see [Table 15](#)).

8.3.1.1 Temperature measurement

The PCF2127 has a temperature sensor circuit used to perform the temperature compensation of the frequency. The temperature is measured immediately after power-on and then periodically with a period set by the temperature conversion rate TCR[1:0] in the register CLKOUT_ctl.

Table 14. Temperature measurement period

TCR[1:0]	Temperature measurement period
00	[1] 4 min
01	2 min
10	1 min
11	30 seconds

[1] Default value.

8.3.2 OTP refresh

Each IC is calibrated during production and testing of the device. The calibration parameters are stored on EPROM cells called One Time Programmable (OTP) cells. It is recommended to process an OTP refresh once after the power is up and the oscillator is operating stable. The OTP refresh takes less than 100 ms to complete.

To perform an OTP refresh, bit OTPR has to be cleared (set to logic 0) and then set to logic 1 again.

8.3.3 Clock output

A programmable square wave is available at pin CLKOUT. Operation is controlled by the COF[2:0] control bits in register CLKOUT_ctl. Frequencies of 32.768 kHz (default) down to 1 Hz can be generated for use as system clock, microcontroller clock, charge pump input, or for calibrating the oscillator.

CLKOUT is an open-drain output and enabled at power-on. When disabled, the output is high-impedance.

Table 15. CLKOUT frequency selection

COF[2:0]	CLKOUT frequency (Hz)	Typical duty cycle ^[1]
000 ^{[2][3]}	32768	60 : 40 to 40 : 60
001	16384	50 : 50
010	8192	50 : 50
011	4096	50 : 50
100	2048	50 : 50
101	1024	50 : 50
110	1	50 : 50
111	CLKOUT = high-Z	-

[1] Duty cycle definition: % HIGH-level time : % LOW-level time.

[2] Default value.

[3] The specified accuracy of the RTC can be only achieved with CLKOUT frequencies not equal to 32.768 kHz or if CLKOUT is disabled.

The duty cycle of the selected clock is not controlled, however, due to the nature of the clock generation all but the 32.768 kHz frequencies are 50 : 50.

8.4 Register Aging_offset

Table 16. Aging_offset - crystal aging offset register (address 19h) bit allocation

Bit positions labeled as - are not implemented and return 0 when read.

Bit	7	6	5	4	3	2	1	0
Symbol	-	-	-	-	AO[3:0]			
Reset value	-	-	-	-	1	0	0	0

Table 17. Aging_offset - crystal aging offset register (address 19h) bit description

Bit positions labeled as - are not implemented and return 0 when read.

Bit	Symbol	Value	Description
7 to 4	-	-	unused
3 to 0	AO[3:0]	see Table 18	aging offset value

8.4.1 Crystal aging correction

The PCF2127 has an offset register Aging_offset to correct the crystal aging effects².

The accuracy of the frequency of a quartz crystal depends on its aging. The aging offset adds an adjustment, positive or negative, in the temperature compensation circuit which allows correcting the aging effect.

At 25 °C, the aging offset bits allow a frequency correction of typically 1 ppm per AO[3:0] value, from -7 ppm to +8 ppm.

2. For further information, refer to the application note [Ref. 3 "AN11266"](#).

Table 18. Frequency correction at 25 °C, typical

AO[3:0]		ppm
Decimal	Binary	
0	0000	+8
1	0001	+7
2	0010	+6
3	0011	+5
4	0100	+4
5	0101	+3
6	0110	+2
7	0111	+1
8	1000	[1] 0
9	1001	-1
10	1010	-2
11	1011	-3
12	1100	-4
13	1101	-5
14	1110	-6
15	1111	-7

[1] Default value.

8.5 General purpose 512 bytes static RAM

The PCF2127 contains a general purpose 512 bytes static RAM. This integrated SRAM is battery backed and can therefore be used to store data which is essential for the application to survive a power outage.

9 bits, RA[8:0], define the RAM address pointer in registers RAM_addr_MSB and RAM_addr_LSB. The register address pointer increments after each read or write automatically up to 1Bh and then wraps around to address 00h (see [Figure 5 on page 6](#)).

Data is transferred to or from the RAM by the interface. To write to the RAM, the register RAM_wrt_cmd, to read from the RAM the register RAM_rd_cmd must be addressed explicitly.

8.5.1 Register RAM_addr_MSB

Table 19. RAM_addr_MSB - RAM address MSB register (address 1Ah) bit allocation

Bit positions labeled as - are not implemented and return 0 when read.

Bit	7	6	5	4	3	2	1	0
Symbol	-	-	-	-	-	-	-	RA8
Reset value	-	-	-	-	-	-	-	0

Table 20. RAM_addr_MSB - RAM address MSB register (address 1Ah) bit description

Bit positions labeled as - are not implemented and return 0 when read.

Bit	Symbol	Description
7 to 1	-	unused
0	RA8	RAM address, MSB (9 th bit)

8.5.2 Register RAM_addr_LSB

Table 21. RAM_addr_LSB - RAM address LSB register (address 1Bh) bit allocation

Bit	7	6	5	4	3	2	1	0
Symbol	RA[7:0]							
Reset value	0	0	0	0	0	0	0	0

Table 22. RAM_addr_LSB - RAM address LSB register (address 1Bh) bit description

Bit	Symbol	Description
7 to 0	RA[7:0]	RAM address, LSB (1 st to 8 th bit)

8.5.3 Register RAM_wrt_cmd

Table 23. RAM_wrt_cmd - RAM write command register (address 1Ch) bit description

Bit	Symbol	Description
7 to 0	-	data to be written into RAM

8.5.4 Register RAM_rd_cmd

Table 24. RAM_rd_cmd - RAM read command register (address 1Dh) bit description

Bit	Symbol	Description
7 to 0	-	data to be read from RAM

8.5.5 Operation examples

8.5.5.1 Writing to the RAM

1. Set RAM address:
 - Select register RAM_addr_MSB (send address 1Ah).
 - Set value for bit RA8 (data byte of register 1Ah).
Note: register address will be incremented automatically to 1Bh.
 - Set value for array RA[7:0] (data byte of register 1Bh).
2. Send RAM write command:
 - Select register RAM_wrt_cmd (send address 1Ch).
3. Write data into the RAM:
 - Write n data byte into RAM.

For details, see [Figure 46 on page 69](#).

8.5.5.2 Reading from the RAM

1. Set RAM address:
 - Select register RAM_addr_MSB (send address 1Ah).
 - Set value for bit RA8 (data byte of register 1Ah).
Note: register address will be incremented automatically to 1Bh.
 - Set value for array RA[7:0] (data byte of register 1Bh).
2. Send RAM read command:
 - Select register RAM_rd_cmd (send address 1Dh).
3. Read from the RAM:
 - Read n data byte from the RAM.

For details, see [Figure 47 on page 70](#).

8.6 Power management functions

The PCF2127 has two power supplies:

V_{DD} — the main power supply

V_{BAT} — the battery backup supply

Internally, the PCF2127 is operating with the internal operating voltage $V_{oper(int)}$ which is also available as V_{BBS} on the battery backed output voltage pin, BBS. Depending on the condition of the main power supply and the selected power management function, $V_{oper(int)}$ is either on the potential of V_{DD} or V_{BAT} (see [Section 8.6.4](#)).

Three power management functions are implemented:

Battery switch-over function. monitoring the main power supply V_{DD} and switching to V_{BAT} in case a power fail condition is detected (see [Section 8.6.1](#)).

Battery low detection function. monitoring the status of the battery, V_{BAT} (see [Section 8.6.2](#)).

Extra power fail detection function. monitoring the voltage at the power fail input pin, PFI (see [Section 8.6.3](#)).

The power management functions are controlled by the control bits PWRMNG[2:0] (see [Table 25](#)) in register Control_3 (see [Table 11](#)):

Table 25. Power management control bit description

PWRMNG[2:0]	Function
000	[1] battery switch-over function is enabled in standard mode; battery low detection function is enabled; extra power fail detection function is enabled
001	battery switch-over function is enabled in standard mode; battery low detection function is disabled; extra power fail detection function is enabled
010	battery switch-over function is enabled in standard mode; battery low detection function is disabled; extra power fail detection function is disabled
011	battery switch-over function is enabled in direct switching mode; battery low detection function is enabled; extra power fail detection function is enabled
100	battery switch-over function is enabled in direct switching mode; battery low detection function is disabled; extra power fail detection function is enabled
101	battery switch-over function is enabled in direct switching mode; battery low detection function is disabled; extra power fail detection function is disabled
110	[2] battery switch-over function is disabled - only one power supply (V_{DD}); battery low detection function is disabled; extra power fail detection function is enabled
111	[2] battery switch-over function is disabled - only one power supply (V_{DD}); battery low detection function is disabled; extra power fail detection function is disabled

[1] Default value.

[2] When the battery switch-over function is disabled, the PCF2127 works only with the power supply V_{DD} . V_{BAT} must be put to ground and the battery low detection function is disabled.

8.6.1 Battery switch-over function

The PCF2127 has a backup battery switch-over circuit which monitors the main power supply V_{DD} . When a power failure condition is detected, it automatically switches to the backup battery.

One of two operation modes can be selected:

Standard mode — the power failure condition happens when:

$$V_{DD} < V_{BAT} \text{ AND } V_{DD} < V_{th(sw)bat}$$

$V_{th(sw)bat}$ is the battery switch threshold voltage. Typical value is 2.5 V. The battery switch-over in standard mode works only for $V_{DD} > 2.5$ V

Direct switching mode — the power failure condition happens when $V_{DD} < V_{BAT}$. Direct switching from V_{DD} to V_{BAT} without requiring V_{DD} to drop below $V_{th(sw)bat}$

When a power failure condition occurs and the power supply switches to the battery, the following sequence occurs:

1. The battery switch flag BF (register Control_3) is set logic 1.
2. An interrupt is generated if the control bit BIE (register Control_3) is enabled (see [Section 8.13.7](#)).
3. If the control bit BTSE (register Control_3) is logic 1, the timestamp registers store the time and date when the battery switch occurred (see [Section 8.12.4](#)).
4. The battery switch flag BF is cleared by command; it must be cleared to clear the interrupt.

The interface is disabled in battery backup operation:

- Interface inputs are not recognized, preventing extraneous data being written to the device
- Interface outputs are high-impedance

For further information about I²C-bus communication and battery backup operation, see [Section 9.3 on page 70](#).

8.6.1.1 Standard mode

If $V_{DD} > V_{BAT}$ OR $V_{DD} > V_{th(sw)bat}$: $V_{oper(int)}$ is at V_{DD} potential.

If $V_{DD} < V_{BAT}$ AND $V_{DD} < V_{th(sw)bat}$: $V_{oper(int)}$ is at V_{BAT} potential.

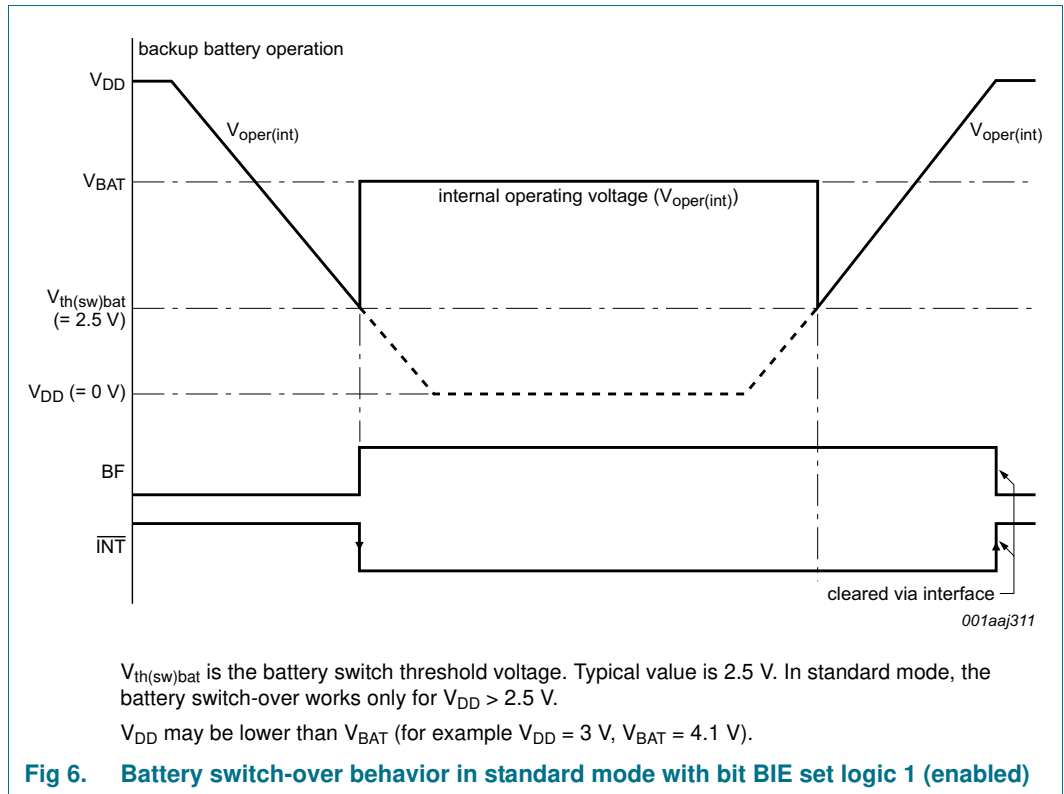

8.6.1.2 Direct switching mode

If $V_{DD} > V_{BAT}$: $V_{oper(int)}$ is at V_{DD} potential.

If $V_{DD} < V_{BAT}$: $V_{oper(int)}$ is at V_{BAT} potential.

The direct switching mode is useful in systems where V_{DD} is always higher than V_{BAT} . This mode is not recommended if the V_{DD} and V_{BAT} values are similar (for example, $V_{DD} = 3.3\text{ V}$, $V_{BAT} \geq 3.0\text{ V}$). In direct switching mode, the power consumption is reduced compared to the standard mode because the monitoring of V_{DD} and $V_{th(sw)bat}$ is not performed.

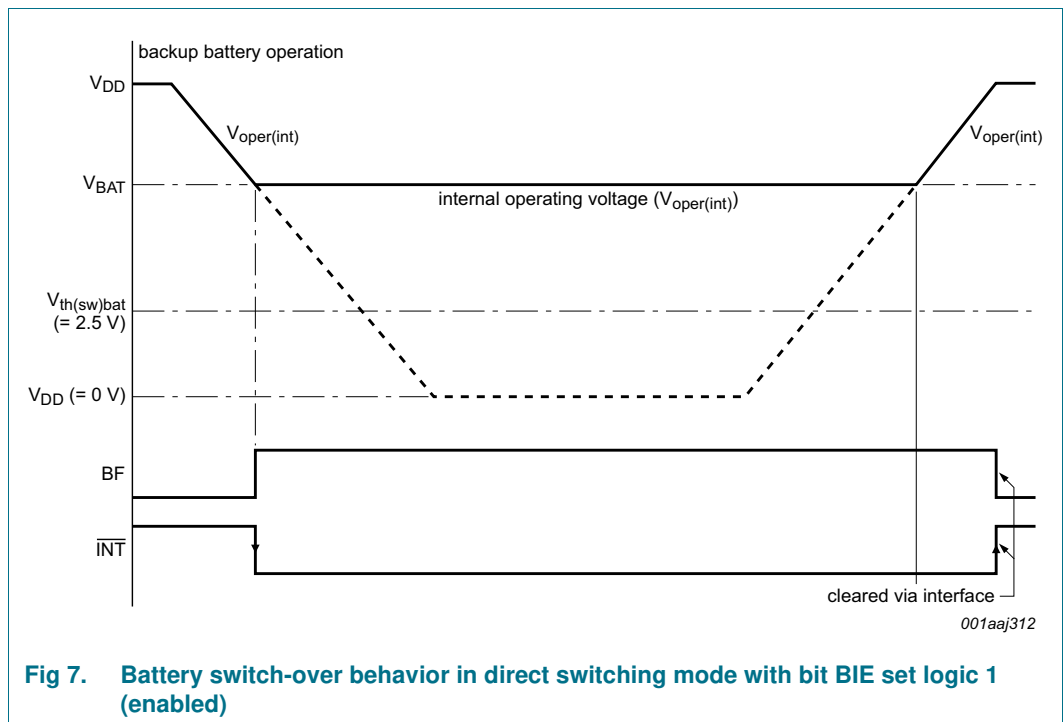

8.6.1.3 Battery switch-over disabled: only one power supply (V_{DD})

When the battery switch-over function is disabled:

- The power supply is applied on the V_{DD} pin
- The V_{BAT} pin must be connected to ground
- $V_{oper(int)}$ is at V_{DD} potential
- The battery flag (BF) is always logic 0

8.6.1.4 Battery switch-over architecture

The architecture of the battery switch-over circuit is shown in [Figure 8](#).

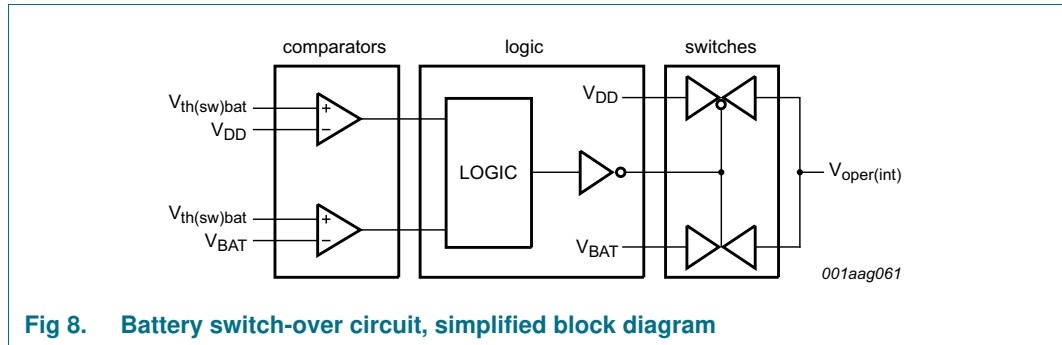

Fig 8. Battery switch-over circuit, simplified block diagram

$V_{oper(int)}$ is at V_{DD} or V_{BAT} potential.

Remark: It has to be assured that there are decoupling capacitors on the pins V_{DD} , V_{BAT} , and BBS.

8.6.2 Battery low detection function

The PCF2127 has a battery low detection circuit which monitors the status of the battery V_{BAT} .

When V_{BAT} drops below the threshold value $V_{th(bat)low}$ (typically 2.5 V), the BLF flag (register Control_3) is set to indicate that the battery is low and that it must be replaced. Monitoring of the battery voltage also occurs during battery operation.

An unreliable battery cannot prevent that the supply voltage drops below V_{low} (typical 1.2 V) and with that the data integrity gets lost. (For further information about V_{low} see [Section 8.7.](#))

When V_{BAT} drops below the threshold value $V_{th(bat)low}$, the following sequence occurs (see [Figure 9](#)):

1. The battery low flag BLF is set logic 1.
2. An interrupt is generated if the control bit BLIE (register Control_3) is enabled (see [Section 8.13.8](#)).
3. The flag BLF remains logic 1 until the battery is replaced. BLF cannot be cleared by command. It is automatically cleared by the battery low detection circuit when the battery is replaced or when the voltage rises again above the threshold value. This could happen if a super capacitor is used as a backup source and the main power is applied again.

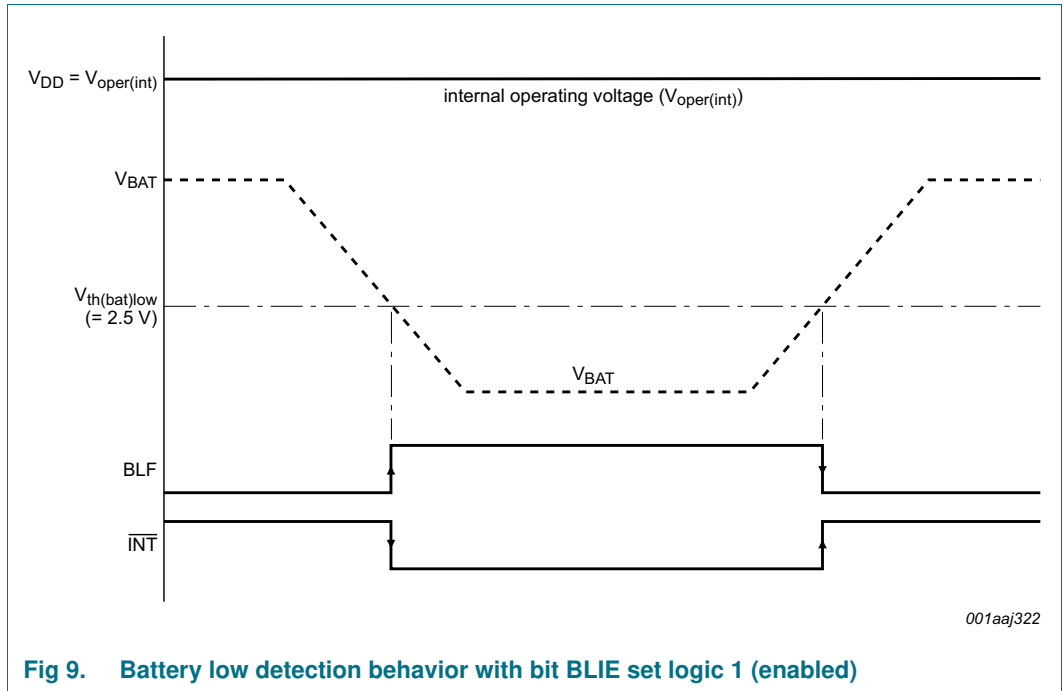

Fig 9. Battery low detection behavior with bit BLIE set logic 1 (enabled)

8.6.3 Extra power fail detection function

The PCF2127 has an extra power fail detection circuit which compares the voltage at the power fail input pin PFI to an internal reference voltage equal to 1.25 V.

If $V_{PFI} < 1.25\text{ V}$, the power fail output \overline{PFO} is driven LOW. \overline{PFO} is an open-drain, active LOW output which requires an external pull-up resistor in any application.

The extra power fail detection function is typically used as a low voltage detection for the main power supply V_{DD} (see [Figure 10](#)).

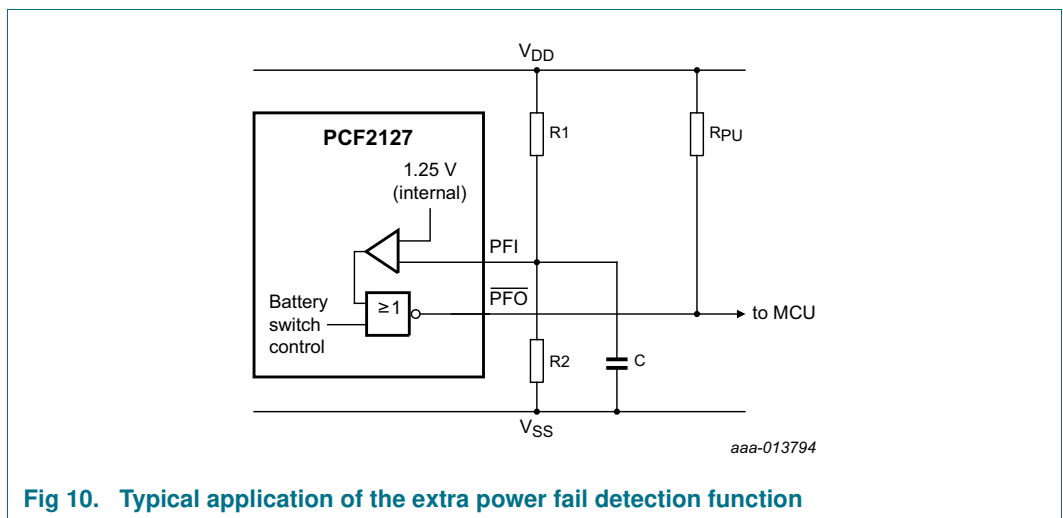

Fig 10. Typical application of the extra power fail detection function

Usually R1 and R2 should be chosen such that the voltage at pin PFI

- is higher than 1.25 V at start-up
- falls below 1.25 V when V_{DD} falls below a desired threshold voltage, $V_{th(uvp)}$, defined by [Equation 1](#):

$$V_{th(uvp)} = \left(\frac{R_1}{R_2} + 1 \right) \times 1.25V \quad (1)$$

$V_{th(uvp)}$ value is usually set to a value that there are several milliseconds before V_{DD} falls below the minimum operating voltage of the system, in order to allow the microcontroller to perform early backup operations, like terminating the communication with the PCF2127.

The value of C is determined from [Equation 2](#):

$$C = \frac{0.02}{(R_1/R_2)} \left[\frac{As}{V} \right] \quad (2)$$

If the extra power fail detection function is not used, pin PFI must be connected to V_{SS} and pin \overline{PFO} must be left open circuit.

8.6.3.1 Extra power fail detection when the battery switch-over function is enabled

- When the power switches to the backup battery supply V_{BAT} , the power fail comparator is switched off and the power fail output at pin \overline{PFO} goes (or remains) LOW
- When the power switches back to the main V_{DD} , the pin \overline{PFO} is not driven LOW anymore. It is pulled HIGH through the external pull-up resistance for a certain time ($t_{rec} = 15.63$ ms to 31.25 ms). Then the power fail comparator is enabled again

For illustration, see [Figure 11](#) and [Figure 12](#).

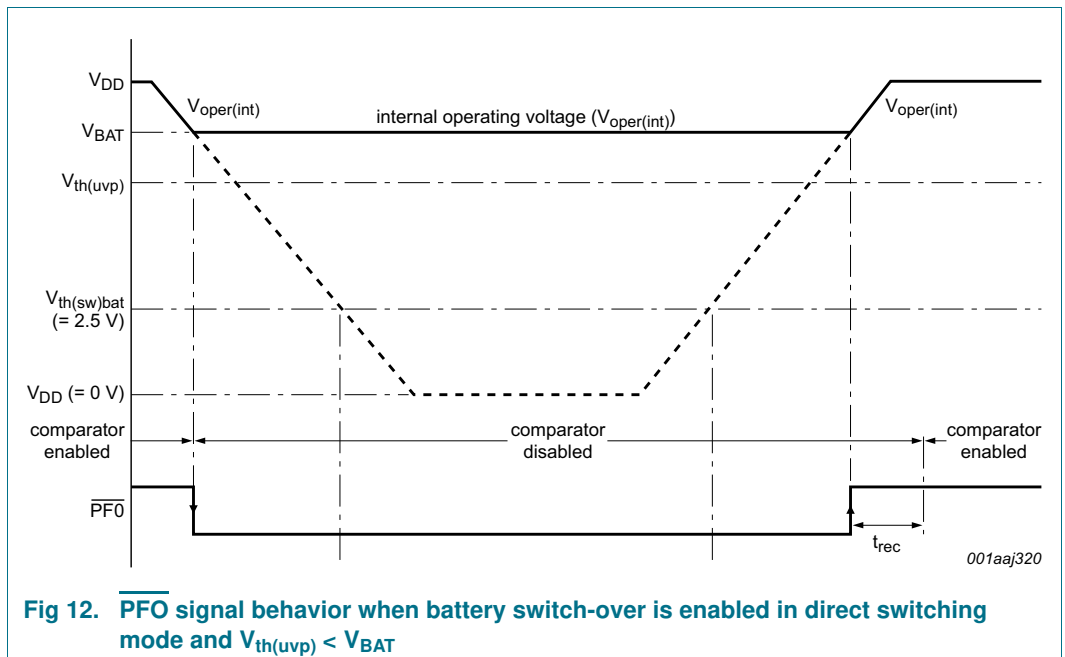
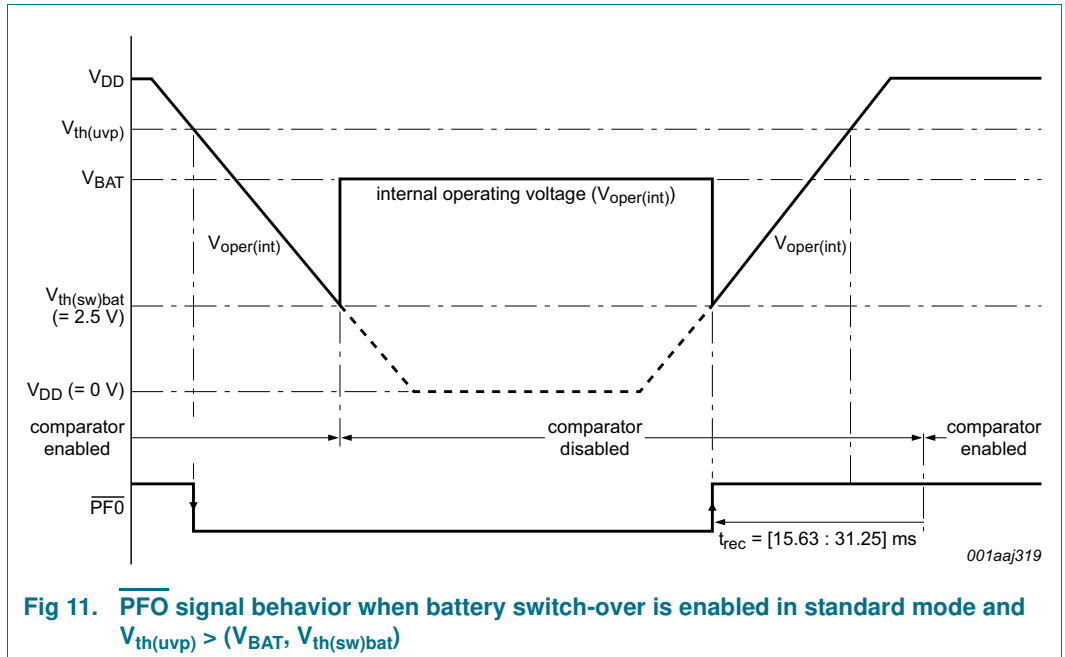

8.6.3.2 Extra power fail detection when the battery switch-over function is disabled

If the battery switch-over function is disabled and the power fail comparator is enabled, the power fail output at pin $\overline{\text{PFO}}$ depends only on the result of the comparison between V_{PFI} and 1.25 V:

- If $V_{\text{PFI}} > 1.25 \text{ V}$, $\overline{\text{PFO}} = \text{HIGH}$ (through the external pull-up resistor)
- If $V_{\text{PFI}} < 1.25 \text{ V}$, $\overline{\text{PFO}} = \text{LOW}$

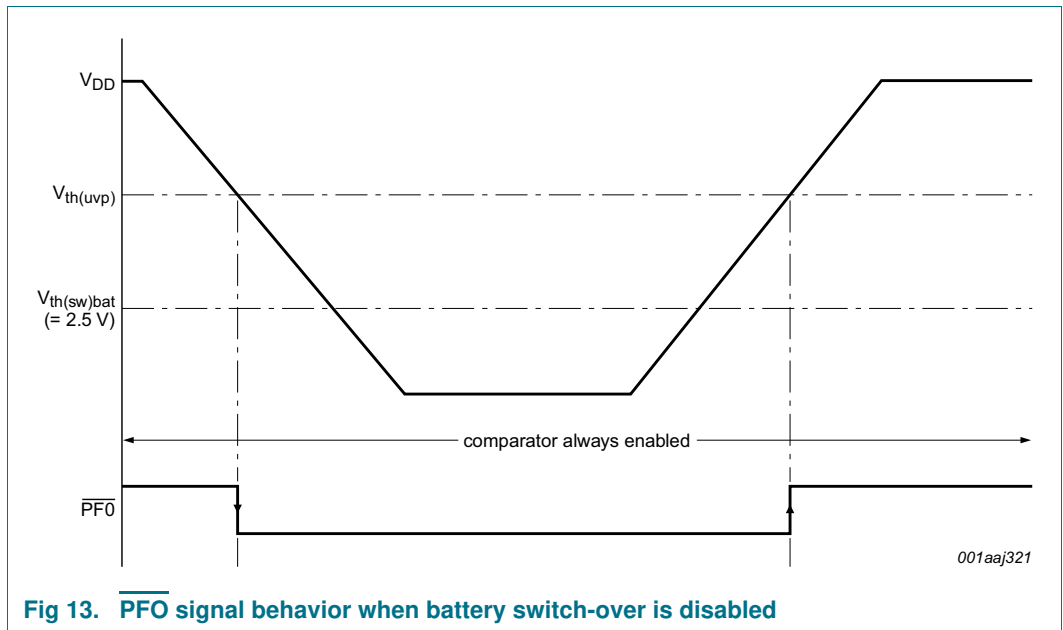

Fig 13. $\overline{\text{PFO}}$ signal behavior when battery switch-over is disabled

8.6.4 Battery backup supply

The V_{BBS} voltage on the output pin BBS is at the same potential as the internal operating voltage $V_{\text{oper(int)}}$, depending on the selected battery switch-over function mode:

Table 26. Output pin BBS

Battery switch-over function mode	Conditions	Potential of $V_{\text{oper(int)}}$ and V_{BBS}
standard	$V_{\text{DD}} > V_{\text{BAT}}$ OR $V_{\text{DD}} > V_{\text{th(sw)bat}}$	V_{DD}
	$V_{\text{DD}} < V_{\text{BAT}}$ AND $V_{\text{DD}} < V_{\text{th(sw)bat}}$	V_{BAT}
direct switching	$V_{\text{DD}} > V_{\text{BAT}}$	V_{DD}
	$V_{\text{DD}} < V_{\text{BAT}}$	V_{BAT}
disabled	only V_{DD} available, V_{BAT} must be put to ground	V_{DD}

The output pin BBS can be used as a supply for external devices with battery backup needs, such as SRAM (see [Ref. 3 “AN11266”](#)). For this case, [Figure 14](#) shows the typical driving capability when V_{BBS} is driven from V_{DD} .

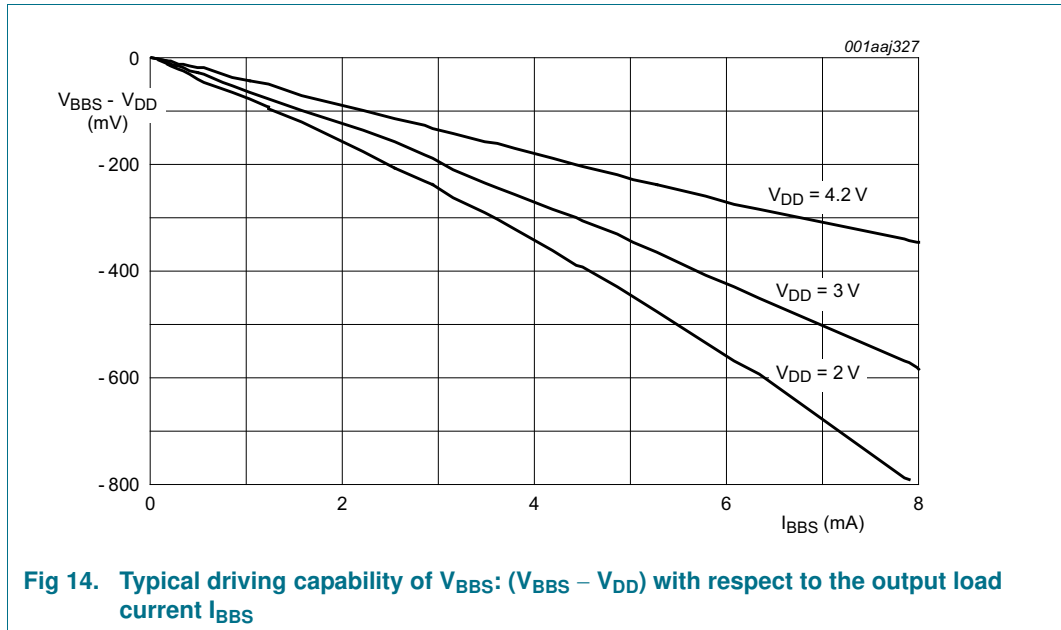

8.7 Oscillator stop detection function

The PCF2127 has an on-chip oscillator detection circuit which monitors the status of the oscillation: whenever the oscillation stops, a reset occurs and the oscillator stop flag OSF (in register Seconds) is set logic 1.

- **Power-on:**
 - a. The oscillator is not running, the chip is in reset (OSF is logic 1).
 - b. When the oscillator starts running and is stable after power-on, the chip exits from reset.
 - c. The flag OSF is still logic 1 and can be cleared (OSF set logic 0) by command.
- **Power supply failure:**
 - a. When the power supply of the chip drops below a certain value (V_{low}), typically 1.2 V, the oscillator stops running and a reset occurs.
 - b. When the power supply returns to normal operation, the oscillator starts running again, the chip exits from reset.
 - c. The flag OSF is still logic 1 and can be cleared (OSF set logic 0) by command.

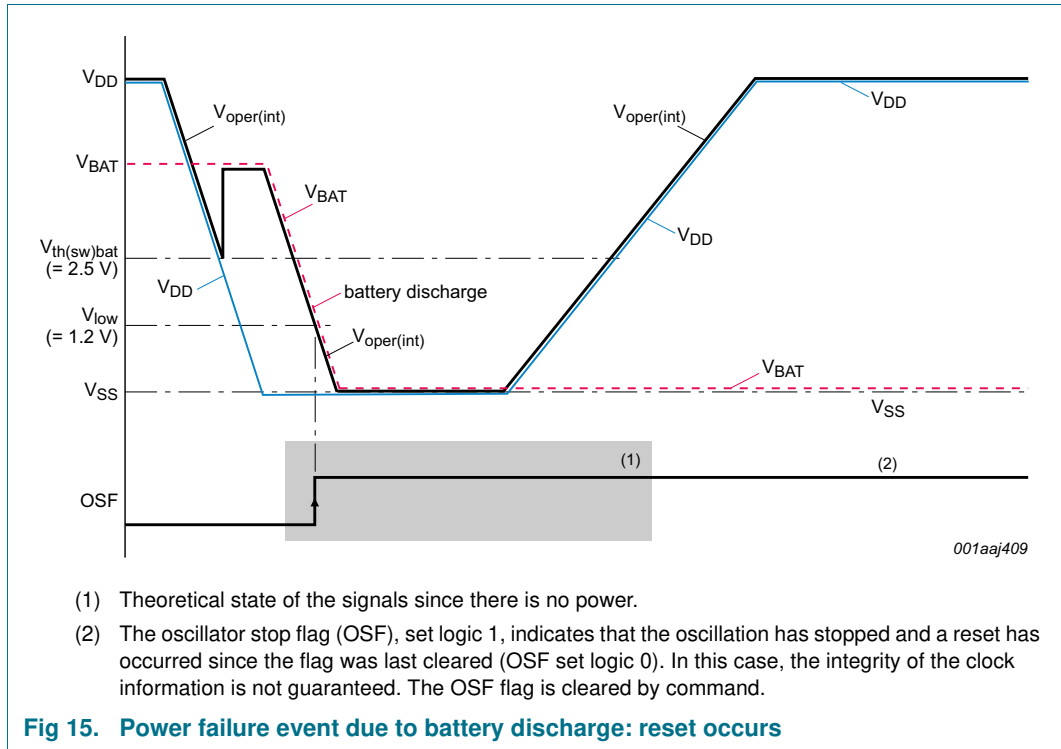

Fig 15. Power failure event due to battery discharge: reset occurs

8.8 Reset function

The PCF2127 has a Power-On Reset (POR) and a Power-On Reset Override (PORO) function implemented.

8.8.1 Power-On Reset (POR)

The POR is active whenever the oscillator is stopped. The oscillator is considered to be stopped during the time between power-on and stable crystal resonance (see [Figure 16](#)). This time may be in the range of 200 ms to 2 s depending on temperature and supply voltage. Whenever an internal reset occurs, the oscillator stop flag is set (OSF set logic 1).

The OTP refresh (see [Section 8.3.2 on page 13](#)) should ideally be executed as the first instruction after start-up and also after a reset due to an oscillator stop.

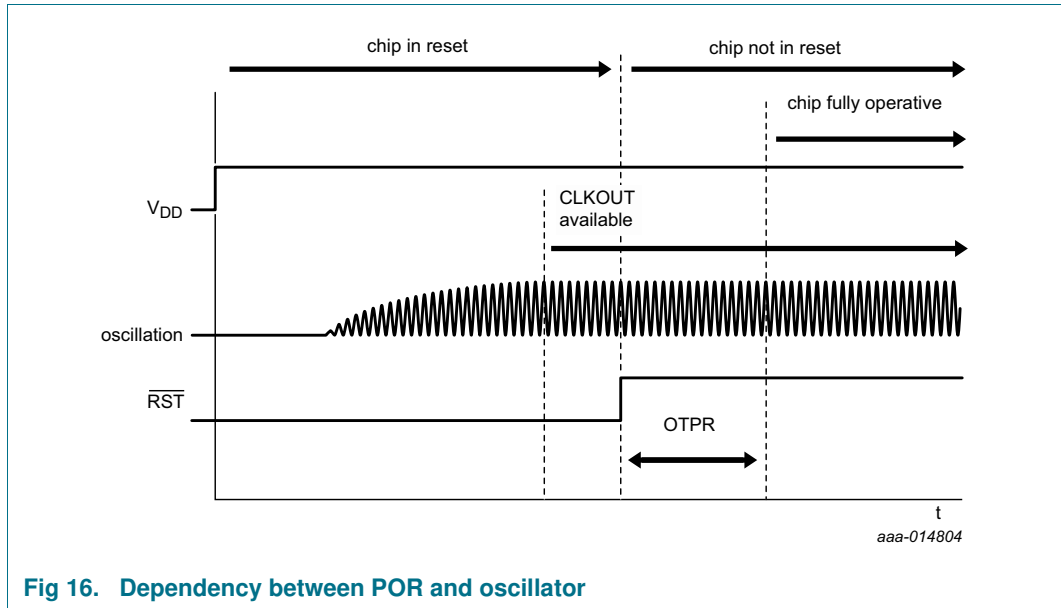

After POR, the following mode is entered:

- 32.768 kHz CLKOUT active
- Power-On Reset Override (PORO) available to be set
- 24-hour mode is selected
- Battery switch-over is enabled
- Battery low detection is enabled
- Extra power fail detection is enabled

The register values after power-on are shown in [Table 5 on page 8](#).

8.8.2 Power-On Reset Override (PORO)

The POR duration is directly related to the crystal oscillator start-up time. Due to the long start-up times experienced by these types of circuits, a mechanism has been built in to disable the POR and therefore speed up the on-board test of the device.

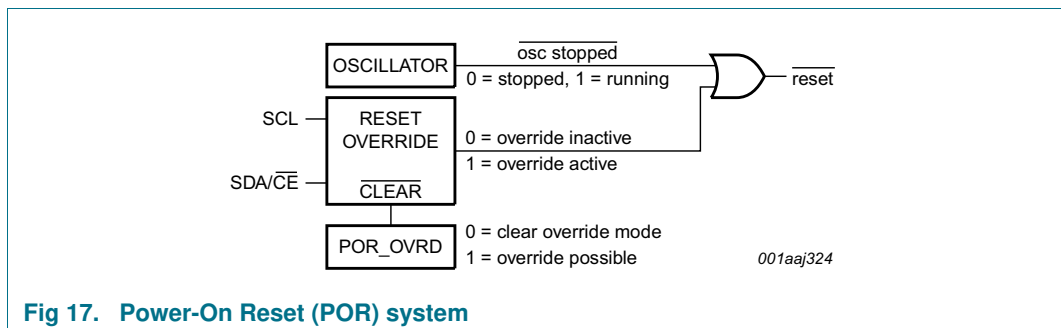

The setting of the PORO mode requires that POR_OVRD in register Control_1 is set logic 1 and that the signals at the interface pins SDA/CÉ and SCL are toggled as illustrated in [Figure 18](#). All timings shown are required minimum.

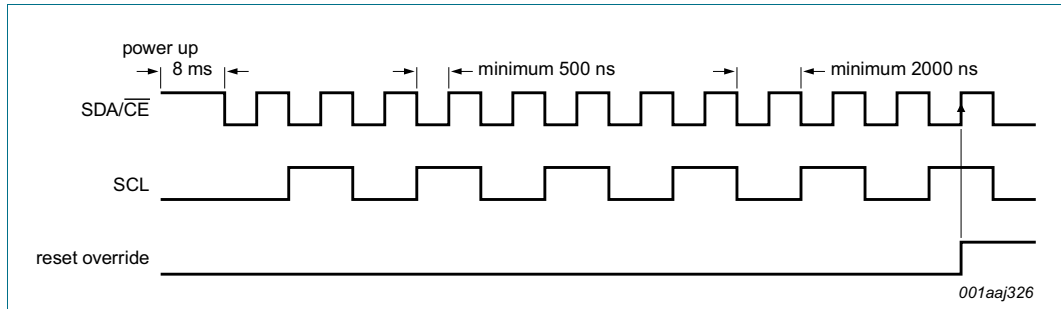

Fig 18. Power-On Reset Override (PORO) sequence, valid for both I²C-bus and SPI-bus

Once the override mode is entered, the device is immediately released from the reset state and the set-up operation can commence.

The PORO mode is cleared by writing logic 0 to POR_OVRD. POR_OVRD must be logic 1 before a re-entry into the override mode is possible. Setting POR_OVRD logic 0 during normal operation has no effect except to prevent accidental entry into the PORO mode.

8.9 Time and date function

Most of these registers are coded in the Binary Coded Decimal (BCD) format.

8.9.1 Register Seconds

Table 27. Seconds - seconds and clock integrity register (address 03h) bit allocation

Bits labeled as X are undefined at power-on and unchanged by subsequent resets.

Bit	7	6	5	4	3	2	1	0
Symbol	OSF	SECONDS (0 to 59)						
Reset value	1	X	X	X	X	X	X	X

Table 28. Seconds - seconds and clock integrity register (address 03h) bit description

Bits labeled as X are undefined at power-on and unchanged by subsequent resets.

Bit	Symbol	Value	Place value	Description
7	OSF	0	-	clock integrity is guaranteed
		1	-	clock integrity is not guaranteed: oscillator has stopped and chip reset has occurred since flag was last cleared
6 to 4	SECONDS	0 to 5	ten's place	actual seconds coded in BCD format
3 to 0		0 to 9	unit place	

Table 29. Seconds coded in BCD format

Seconds value in decimal	Upper-digit (ten's place)			Digit (unit place)			
	Bit 6	Bit 5	Bit 4	Bit 3	Bit 2	Bit 1	Bit 0
00	0	0	0	0	0	0	0
01	0	0	0	0	0	0	1
02	0	0	0	0	0	1	0
:	:	:	:	:	:	:	:
09	0	0	0	1	0	0	1
10	0	0	1	0	0	0	0
:	:	:	:	:	:	:	:
58	1	0	1	1	0	0	0
59	1	0	1	1	0	0	1

8.9.2 Register Minutes

Table 30. Minutes - minutes register (address 04h) bit allocation

Bit positions labeled as - are not implemented and return 0 when read. Bits labeled as X are undefined at power-on and unchanged by subsequent resets.

Bit	7	6	5	4	3	2	1	0
Symbol	-	MINUTES (0 to 59)						
Reset value	-	X	X	X	X	X	X	X

Table 31. Minutes - minutes register (address 04h) bit description

Bit positions labeled as - are not implemented and return 0 when read. Bits labeled as X are undefined at power-on and unchanged by subsequent resets.

Bit	Symbol	Value	Place value	Description
7	-	-	-	unused
6 to 4	MINUTES	0 to 5	ten's place	actual minutes coded in BCD format
3 to 0		0 to 9	unit place	

8.9.3 Register Hours

Table 32. Hours - hours register (address 05h) bit allocation

Bit positions labeled as - are not implemented and return 0 when read. Bits labeled as X are undefined at power-on and unchanged by subsequent resets.

Bit	7	6	5	4	3	2	1	0
Symbol	-	-	AMPM	HOURS (1 to 12) in 12-hour mode				
			HOURS (0 to 23) in 24-hour mode					
Reset value	-	-	X	X	X	X	X	X

Table 33. Hours - hours register (address 05h) bit description

Bit positions labeled as - are not implemented and return 0 when read. Bits labeled as X are undefined at power-on and unchanged by subsequent resets.

Bit	Symbol	Value	Place value	Description
7 to 6	-	-	-	unused
12-hour mode^[1]				
5	AMPM	0	-	indicates AM
		1	-	indicates PM
4	HOURS	0 to 1	ten's place	actual hours coded in BCD format when in 12-hour mode
3 to 0		0 to 9	unit place	
24-hour mode^[1]				
5 to 4	HOURS	0 to 2	ten's place	actual hours coded in BCD format when in 24-hour mode
3 to 0		0 to 9	unit place	

[1] Hour mode is set by the bit 12_24 in register Control_1 (see [Table 7](#)).

8.9.4 Register Days

Table 34. Days - days register (address 06h) bit allocation

Bit positions labeled as - are not implemented and return 0 when read. Bits labeled as X are undefined at power-on and unchanged by subsequent resets.

Bit	7	6	5	4	3	2	1	0
Symbol	-	-	DAYS (1 to 31)					
Reset value	-	-	X	X	X	X	X	X

Table 35. Days - days register (address 06h) bit description

Bit	Symbol	Value	Place value	Description
7 to 6	-	-	-	unused
5 to 4	DAYS ^[1]	0 to 3	ten's place	actual day coded in BCD format
3 to 0		0 to 9	unit place	

[1] If the year counter contains a value which is exactly divisible by 4, including the year 00, the RTC compensates for leap years by adding a 29th day to February.

8.9.5 Register Weekdays

Table 36. Weekdays - weekdays register (address 07h) bit allocation

Bit positions labeled as - are not implemented and return 0 when read. Bits labeled as X are undefined at power-on and unchanged by subsequent resets.

Bit	7	6	5	4	3	2	1	0
Symbol	-	-	-	-	-	WEEKDAYS (0 to 6)		
Reset value	-	-	-	-	-	X	X	X

Table 37. Weekdays - weekdays register (address 07h) bit description

Bit positions labeled as - are not implemented and return 0 when read. Bits labeled as X are undefined at power-on and unchanged by subsequent resets.

Bit	Symbol	Value	Description
7 to 3	-	-	unused
2 to 0	WEEKDAYS	0 to 6	actual weekday value, see Table 38

Although the association of the weekdays counter to the actual weekday is arbitrary, the PCF2127 assumes that Sunday is 000 and Monday is 001 for the purpose of determining the increment for calendar weeks.

Table 38. Weekday assignments

Day ^[1]	Bit		
	2	1	0
Sunday	0	0	0
Monday	0	0	1
Tuesday	0	1	0
Wednesday	0	1	1
Thursday	1	0	0
Friday	1	0	1
Saturday	1	1	0

[1] Definition may be reassigned by the user.

8.9.6 Register Months

Table 39. Months - months register (address 08h) bit allocation

Bit positions labeled as - are not implemented and return 0 when read. Bits labeled as X are undefined at power-on and unchanged by subsequent resets.

Bit	7	6	5	4	3	2	1	0
Symbol	-	-	-	MONTHS (1 to 12)				
Reset value	-	-	-	X	X	X	X	X

Table 40. Months - months register (address 08h) bit description

Bit positions labeled as - are not implemented and return 0 when read. Bits labeled as X are undefined at power-on and unchanged by subsequent resets.

Bit	Symbol	Value	Place value	Description
7 to 5	-	-	-	unused
4	MONTHS	0 to 1	ten's place	actual month coded in BCD format, see Table 41
3 to 0		0 to 9	unit place	

Table 41. Month assignments in BCD format

Month	Upper-digit (ten's place)	Digit (unit place)			
	Bit 4	Bit 3	Bit 2	Bit 1	Bit 0
January	0	0	0	0	1
February	0	0	0	1	0
March	0	0	0	1	1
April	0	0	1	0	0
May	0	0	1	0	1
June	0	0	1	1	0
July	0	0	1	1	1
August	0	1	0	0	0
September	0	1	0	0	1
October	1	0	0	0	0
November	1	0	0	0	1
December	1	0	0	1	0

8.9.7 Register Years

Table 42. Years - years register (address 09h) bit allocation

Bits labeled as X are undefined at power-on and unchanged by subsequent resets.

Bit	7	6	5	4	3	2	1	0
Symbol	YEARS (0 to 99)							
Reset value	X	X	X	X	X	X	X	X

Table 43. Years - years register (address 09h) bit description

Bits labeled as X are undefined at power-on and unchanged by subsequent resets.

Bit	Symbol	Value	Place value	Description
7 to 4	YEARS	0 to 9	ten's place	actual year coded in BCD format
3 to 0		0 to 9	unit place	

8.9.8 Setting and reading the time

Figure 19 shows the data flow and data dependencies starting from the 1 Hz clock tick.

During read/write operations, the time counting circuits (memory locations 03h through 09h) are blocked.

This prevents

- Faulty reading of the clock and calendar during a carry condition
- Incrementing the time registers during the read cycle

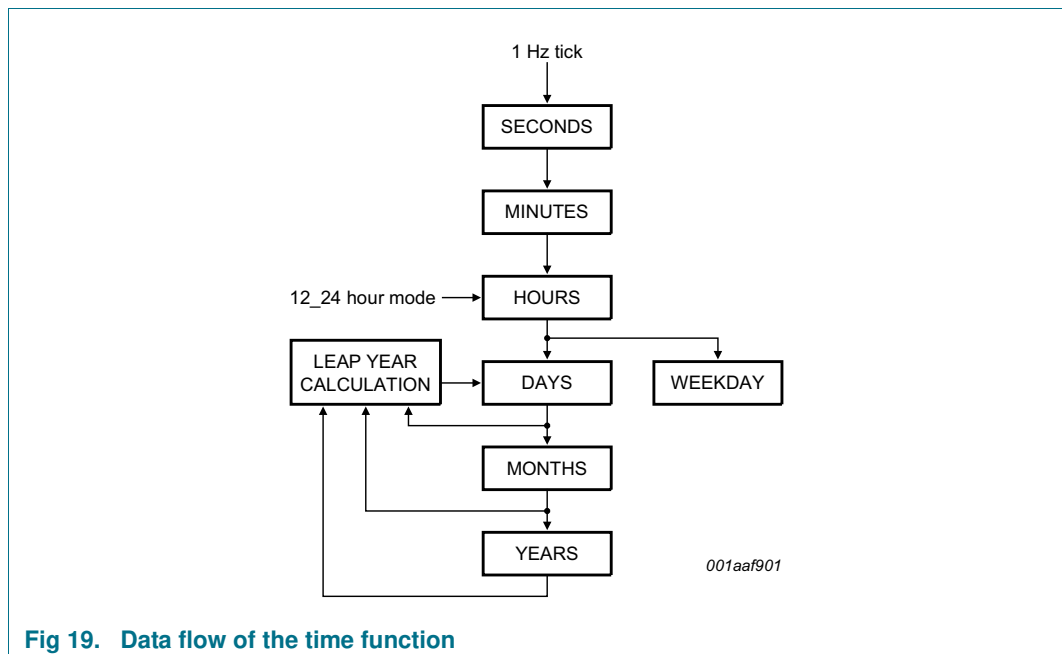

Fig 19. Data flow of the time function

After this read/write access is completed, the time circuit is released again. Any pending request to increment the time counters that occurred during the read/write access is serviced. A maximum of 1 request can be stored; therefore, all accesses must be completed within 1 second (see Figure 20).

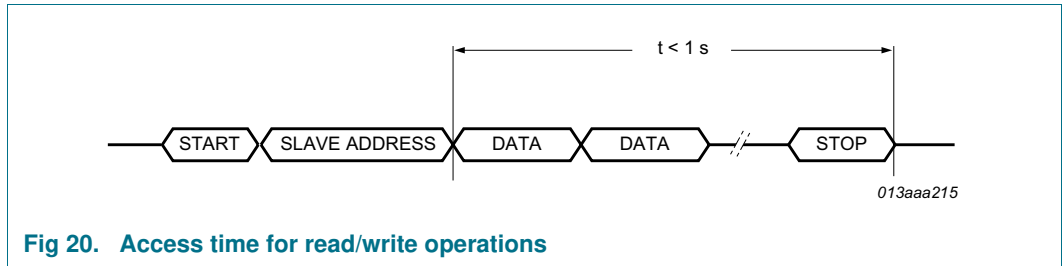

Fig 20. Access time for read/write operations

As a consequence of this method, it is very important to make a read or write access in one go. That is, setting or reading seconds through to years should be made in one single access. Failing to comply with this method could result in the time becoming corrupted.

As an example, if the time (seconds through to hours) is set in one access and then in a second access the date is set, it is possible that the time may increment between the two accesses. A similar problem exists when reading. A roll-over may occur between reads thus giving the minutes from one moment and the hours from the next. Therefore it is advised to read all time and date registers in one access.

8.10 Alarm function

When one or more of the alarm bit fields are loaded with a valid second, minute, hour, day, or weekday and its corresponding alarm enable bit (AE_x) is logic 0, then that information is compared with the actual second, minute, hour, day, and weekday (see [Figure 21](#)).

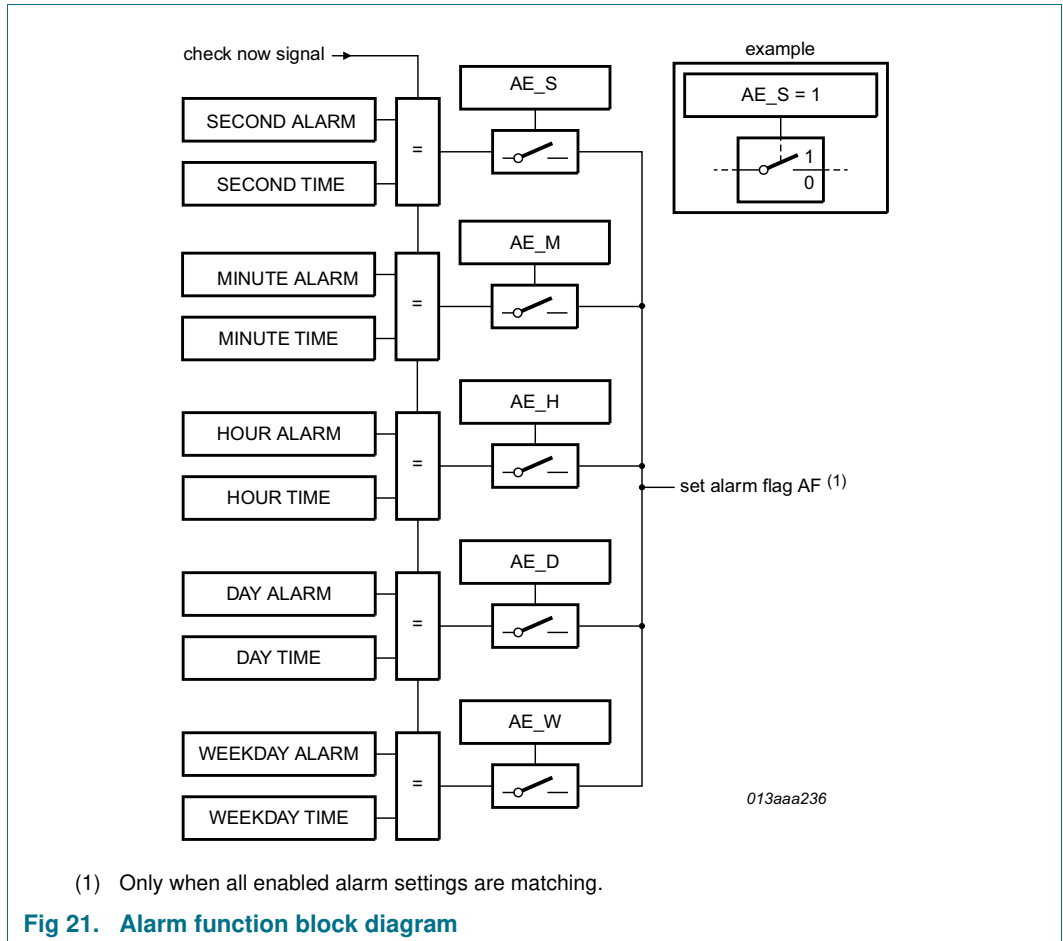

The generation of interrupts from the alarm function is described in [Section 8.13.5](#).

8.10.1 Register Second_alarm

Table 44. Second_alarm - second alarm register (address 0Ah) bit allocation

Bits labeled as X are undefined at power-on and unchanged by subsequent resets.

Bit	7	6	5	4	3	2	1	0
Symbol	AE_S	SECOND_ALARM (0 to 59)						
Reset value	1	X	X	X	X	X	X	X

Table 45. Second_alarm - second alarm register (address 0Ah) bit description

Bit	Symbol	Value	Place value	Description
7	AE_S	0	-	second alarm is enabled
		1	-	second alarm is disabled
6 to 4	SECOND_ALARM	0 to 5	ten's place	second alarm information coded in BCD format
3 to 0		0 to 9	unit place	

8.10.2 Register Minute_alarm

Table 46. Minute_alarm - minute alarm register (address 0Bh) bit allocation

Bits labeled as X are undefined at power-on and unchanged by subsequent resets.

Bit	7	6	5	4	3	2	1	0
Symbol	AE_M	MINUTE_ALARM (0 to 59)						
Reset value	1	X	X	X	X	X	X	X

Table 47. Minute_alarm - minute alarm register (address 0Bh) bit description

Bits labeled as X are undefined at power-on and unchanged by subsequent resets.

Bit	Symbol	Value	Place value	Description
7	AE_M	0	-	minute alarm is enabled
		1	-	minute alarm is disabled
6 to 4	MINUTE_ALARM	0 to 5	ten's place	minute alarm information coded in BCD format
3 to 0		0 to 9	unit place	

8.10.3 Register Hour_alarm

Table 48. Hour_alarm - hour alarm register (address 0Ch) bit allocation

Bit positions labeled as - are not implemented and return 0 when read. Bits labeled as X are undefined at power-on and unchanged by subsequent resets.

Bit	7	6	5	4	3	2	1	0
Symbol	AE_H	-	AMPM	HOUR_ALARM (1 to 12) in 12-hour mode				
			HOUR_ALARM (0 to 23) in 24-hour mode					
Reset value	1	-	X	X	X	X	X	X

Table 49. Hour_alarm - hour alarm register (address 0Ch) bit description

Bit positions labeled as - are not implemented and return 0 when read. Bits labeled as X are undefined at power-on and unchanged by subsequent resets.

Bit	Symbol	Value	Place value	Description
7	AE_H	0	-	hour alarm is enabled
		1	-	hour alarm is disabled
6	-	-	-	unused
12-hour mode^[1]				
5	AMPM	0	-	indicates AM
		1	-	indicates PM
4	HOUR_ALARM	0 to 1	ten's place	hour alarm information coded in BCD format when in 12-hour mode
3 to 0		0 to 9	unit place	
24-hour mode^[1]				
5 to 4	HOUR_ALARM	0 to 2	ten's place	hour alarm information coded in BCD format when in 24-hour mode
3 to 0		0 to 9	unit place	

[1] Hour mode is set by the bit 12_24 in register Control_1.

8.10.4 Register Day_alarm

Table 50. Day_alarm - day alarm register (address 0Dh) bit allocation

Bit positions labeled as - are not implemented and return 0 when read. Bits labeled as X are undefined at power-on and unchanged by subsequent resets.

Bit	7	6	5	4	3	2	1	0
Symbol	AE_D	-	DAY_ALARM (1 to 31)					
Reset value	1	-	X	X	X	X	X	X

Table 51. Day_alarm - day alarm register (address 0Dh) bit description

Bit positions labeled as - are not implemented and return 0 when read. Bits labeled as X are undefined at power-on and unchanged by subsequent resets.

Bit	Symbol	Value	Place value	Description
7	AE_D	0	-	day alarm is enabled
		1	-	day alarm is disabled
6	-	-	-	unused
5 to 4	DAY_ALARM	0 to 3	ten's place	day alarm information coded in BCD format
3 to 0		0 to 9	unit place	

8.10.5 Register Weekday_alarm

Table 52. Weekday_alarm - weekday alarm register (address 0Eh) bit allocation

Bit positions labeled as - are not implemented and return 0 when read. Bits labeled as X are undefined at power-on and unchanged by subsequent resets.

Bit	7	6	5	4	3	2	1	0
Symbol	AE_W	-	-	-	-	WEEKDAY_ALARM (0 to 6)		
Reset value	1	-	-	-	-	X	X	X

Table 53. Weekday_alarm - weekday alarm register (address 0Eh) bit description

Bit positions labeled as - are not implemented and return 0 when read. Bits labeled as X are undefined at power-on and unchanged by subsequent resets.

Bit	Symbol	Value	Description
7	AE_W	0	weekday alarm is enabled
		1	weekday alarm is disabled
6 to 3	-	-	unused
2 to 0	WEEKDAY_ALARM	0 to 6	weekday alarm information

8.10.6 Alarm flag

When all enabled comparisons first match, the alarm flag AF (register Control_2) is set. AF remains set until cleared by command. Once AF has been cleared, it will only be set again when the time increments to match the alarm condition once more. For clearing the flags, see [Section 8.11.6](#)

Alarm registers which have their alarm enable bit AE_x at logic 1 are ignored.

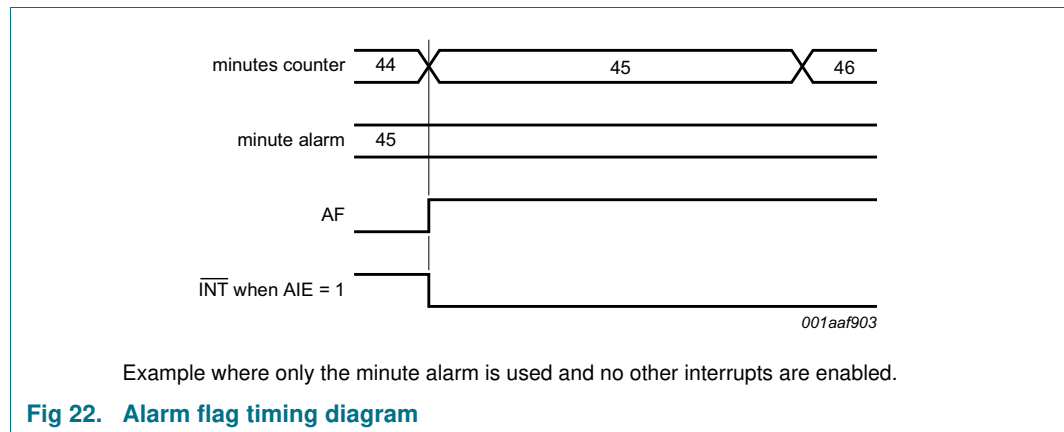

Fig 22. Alarm flag timing diagram

8.11 Timer functions

The PCF2127 has two different timer functions, a watchdog timer and a countdown timer. The timers can be selected by using the control bits WD_CD[1:0] in the register Watchdog_tim_ctl.

- The watchdog timer has four selectable source clocks. It can, for example, be used to detect a microcontroller with interrupt and reset capability which is out of control (see [Section 8.11.3](#))

- The countdown timer has four selectable source clocks allowing for countdown periods from less than 1 ms to more than 4 hours (see [Section 8.11.4](#))

To control the timer functions and timer output, the registers Control_2, Watchdg_tim_ctl, and Watchdg_tim_val are used.

8.11.1 Register Watchdg_tim_ctl

Table 54. Watchdg_tim_ctl - watchdog timer control register (address 10h) bit allocation

Bit positions labeled as - are not implemented and return 0 when read.

Bit	7	6	5	4	3	2	1	0
Symbol	WD_CD[1:0]		TI_TP	-	-	-	TF[1:0]	
Reset value	0	0	0	-	-	-	1	1

Table 55. Watchdg_tim_ctl - watchdog timer control register (address 10h) bit description

Bit positions labeled as - are not implemented and return 0 when read.

Bit	Symbol	Value	Description
7 to 6	WD_CD[1:0]	00	Watchdog timer disabled; countdown timer disabled
		01	watchdog timer disabled; countdown timer enabled if CDTIE is set logic 1, the interrupt pin $\overline{\text{INT}}$ is activated when the countdown timed out
		10	watchdog timer enabled; the interrupt pin $\overline{\text{INT}}$ is activated when timed out; countdown timer not available
		11	watchdog timer enabled; the reset pin $\overline{\text{RST}}$ is activated when timed out; countdown timer not available
5	TI_TP	0	the interrupt pin $\overline{\text{INT}}$ is configured to generate a permanent active signal when MSF and/or CDTF is set
		1	the interrupt pin $\overline{\text{INT}}$ is configured to generate a pulsed signal when MSF flag and/or CDTF flag is set (see Figure 27)
4 to 2	-	-	unused
1 to 0	TF[1:0]		timer source clock for watchdog and countdown timer
		00	4.096 kHz
		01	64 Hz
		10	1 Hz
		11	$\frac{1}{60}$ Hz

8.11.2 Register Watchdg_tim_val

Table 56. Watchdg_tim_val - watchdog timer value register (address 11h) bit allocation

Bits labeled as X are undefined at power-on and unchanged by subsequent resets.

Bit	7	6	5	4	3	2	1	0
Symbol	WATCHDGDG_TIM_VAL[7:0]							
Reset value	X	X	X	X	X	X	X	X

Table 57. Watchdg_tim_val - watchdog timer value register (address 11h) bit description

Bits labeled as X are undefined at power-on and unchanged by subsequent resets.

Bit	Symbol	Value	Description
7 to 0	WATCHDGDG_TIM_VAL[7:0]	00 to FF	timer period in seconds: $TimerPeriod = \frac{n}{SourceClockFrequency}$ where n is the timer value

Table 58. Programmable watchdog timer

TF[1:0]	Timer source clock frequency	Units	Minimum timer period (n = 1)	Units	Maximum timer period (n = 255)	Units
00	4.096	kHz	244	μs	62.256	ms
01	64	Hz	15.625	ms	3.984	s
10	1	Hz	1	s	255	s
11	1/60	Hz	60	s	15300	s

8.11.3 Watchdog timer function

The watchdog timer function is enabled or disabled by the WD_CD[1:0] bits of the register Watchdg_tim_ctl (see [Table 55](#)).

The two bits TF[1:0] in register Watchdg_tim_ctl determine one of the four source clock frequencies for the watchdog timer: 4.096 kHz, 64 Hz, 1 Hz, or 1/60 Hz (see [Table 58](#)).

When the watchdog timer function is enabled, the 8-bit timer in register Watchdg_tim_val determines the watchdog timer period (see [Table 58](#)).

The watchdog timer counts down from the software programmed 8-bit binary value n in register Watchdg_tim_val. When the counter reaches 1, the watchdog timer flag WDTF (register Control_2) is set logic 1.

If WDTF is logic 1 and:

- if WD_CD[1:0] = 10 an interrupt will be generated
- if WD_CD[1:0] = 11 a reset will be generated

The counter does not automatically reload.

When WD_CD[1:0] = 10 or WD_CD[1:0] = 11 and the Microcontroller Unit (MCU) loads a watchdog timer value n:

- the flag WDTF is reset
- \overline{INT} or \overline{RST} is cleared

- the watchdog timer starts again

Loading the counter with 0 will:

- reset the flag WDTF
- clear $\overline{\text{INT}}$ or $\overline{\text{RST}}$
- stop the watchdog timer

Remark: WDTF is read only and cannot be cleared by command. WDTF can be cleared by:

- loading a value in register Watchdg_tim_val
- reading of the register Control_2

Writing a logic 0 or logic 1 to WDTF has no effect.

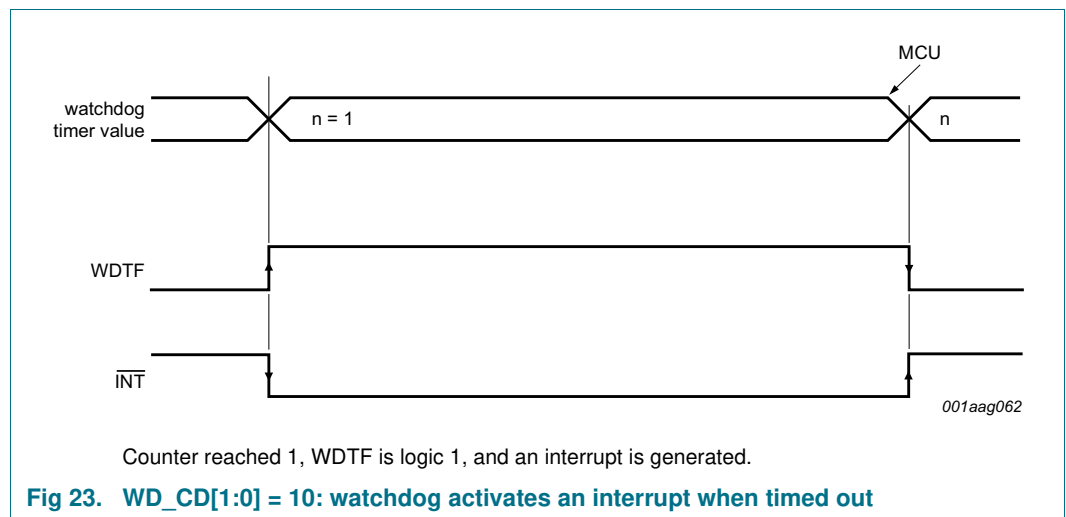

- When the watchdog timer counter reaches 1, the watchdog timer flag WDTF is set logic 1
- When a minute or second interrupt occurs, the minute/second flag MSF is set logic 1 (see [Section 8.13.1](#))

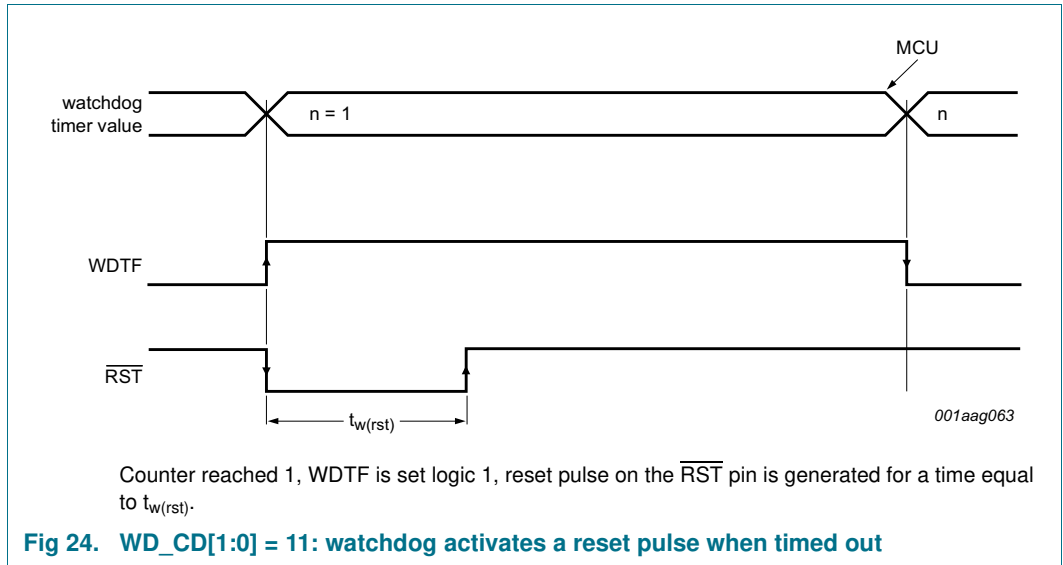

Table 59. Specification of $t_{w(\text{rst})}$

WD_CD[1:0]	TF[1:0]	$t_{w(\text{rst})}$
11	00	244 μs
	01	15.625 ms
	10	15.625 ms
	11	15.625 ms

8.11.4 Countdown timer function

The countdown timer function is controlled by the $\text{WD_CD}[1:0]$ bits in register Watchdg_tim_ctl (see [Table 55](#)).

The timer counts down from the software programmed 8-bit binary value n in register Watchdg_tim_val . When the counter reaches 1

- the countdown timer flag CDTF is set
- the counter automatically reloads
- and the next time period starts

Loading the counter with 0 effectively stops the timer.

Reading the timer returns the actual value of the countdown counter.

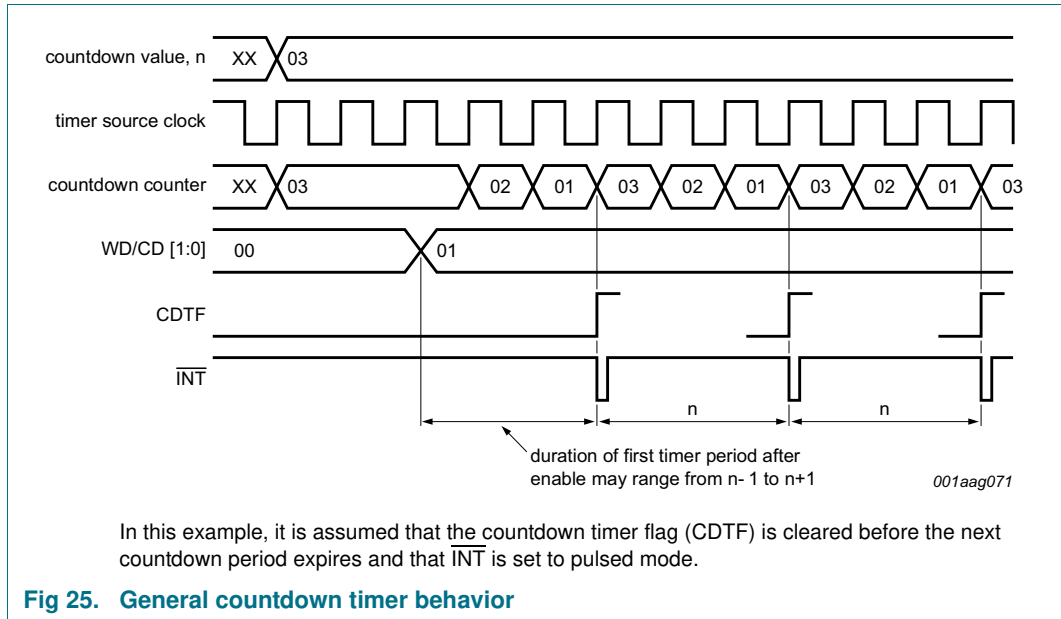

If a new value of n is written before the end of the actual timer period, this value takes immediate effect. It is not recommended to change n without first disabling the counter by setting WD_CD[1:0] = 00. The update of n is asynchronous to the timer clock. Therefore changing it on the fly could result in a corrupted value loaded into the countdown counter. This can result in an undetermined countdown period for the first period. The countdown value n will, however, be correctly stored and correctly loaded on subsequent timer periods.

If this mode is enabled and the countdown timer flag CDTF is set, an interrupt signal on INT will be generated. See Section 8.13.2 for details on how the interrupt can be controlled.

When starting the countdown timer for the first time, only the first period will not have a fixed duration. The amount of inaccuracy for the first timer period depends on the chosen source clock, see Table 60.

Table 60. First period delay for timer counter

Timer source clock	Minimum timer period	Maximum timer period
4.096 kHz	n	n + 1
64 Hz	n	n + 1
1 Hz	$(n - 1) + \frac{1}{64} \text{ Hz}$	$n + \frac{1}{64} \text{ Hz}$
$\frac{1}{60} \text{ Hz}$	$(n - 1) + \frac{1}{64} \text{ Hz}$	$n + \frac{1}{64} \text{ Hz}$

At the end of every countdown, the timer sets the countdown timer flag (CDTF). CDTF may only be cleared by command. The asserted CDTF can be used to generate an interrupt (INT). The interrupt may be generated as a pulsed signal every countdown period or as a permanently active signal which follows the condition of CDTF. TI_TP is used to control this mode selection. The interrupt output may be disabled with the CDTIE bit, see Table 9.

When reading the timer, the actual countdown value is returned and **not** the initial value *n*. Since it is not possible to freeze the countdown timer counter during read back, it is recommended to read the register twice and check for consistent results.

8.11.5 Pre-defined timers: second and minute interrupt

PCF2127 has two pre-defined timers which are used to generate an interrupt either once per second or once per minute (see [Section 8.13.1](#)). The pulse generator for the minute or second interrupt operates from an internal 64 Hz clock. It is independent of the watchdog or countdown timers. Each of these timers can be enabled by the bits SI (second interrupt) and MI (minute interrupt) in register Control_1.

8.11.6 Clearing flags

The flags MSF, CDTF, AF and TSF_x can be cleared by command. To prevent one flag being overwritten while clearing another, a logic AND is performed during the write access. A flag is cleared by writing logic 0 while a flag is not cleared by writing logic 1. Writing logic 1 results in the flag value remaining unchanged.

Four examples are given for clearing the flags. Clearing the flags is made by a write command:

- Bits labeled with - must be written with their previous values
- WDTF is read only and has to be written with logic 0

Repeatedly rewriting these bits has no influence on the functional behavior.

Table 61. Flag location in register Control_2

Register	Bit							
	7	6	5	4	3	2	1	0
Control_2	MSF	WDTF	TSF2	AF	CDTF	-	-	-

Table 62. Example values in register Control_2

Register	Bit							
	7	6	5	4	3	2	1	0
Control_2	1	0	1	1	1	0	0	0

The following tables show what instruction must be sent to clear the appropriate flag.

Table 63. Example to clear only CDTF (bit 3)

Register	Bit							
	7	6	5	4	3	2	1	0
Control_2	1	0	1	1	0	-[1]	-[1]	-[1]

[1] The bits labeled as - have to be rewritten with the previous values.

Table 64. Example to clear only AF (bit 4)

Register	Bit							
	7	6	5	4	3	2	1	0
Control_2	1	0	1	0	1	0[1]	0[1]	0[1]

[1] The bits labeled as - have to be rewritten with the previous values.

Table 65. Example to clear only MSF (bit 7)

Register	Bit							
	7	6	5	4	3	2	1	0
Control_2	0	0	1	1	1	0 ^[1]	0 ^[1]	0 ^[1]

[1] The bits labeled as - have to be rewritten with the previous values.

Table 66. Example to clear both CDTF and MSF

Register	Bit							
	7	6	5	4	3	2	1	0
Control_2	0	0	1	1	0	0 ^[1]	0 ^[1]	0 ^[1]

[1] The bits labeled as - have to be rewritten with the previous values.

8.12 Timestamp function

The PCF2127 has an active LOW timestamp input pin \overline{TS} , internally pulled with an on-chip pull-up resistor to $V_{oper(int)}$. It also has a timestamp detection circuit which can detect two different events:

1. Input on pin \overline{TS} is driven to an intermediate level between power supply and ground.
2. Input on pin \overline{TS} is driven to ground.

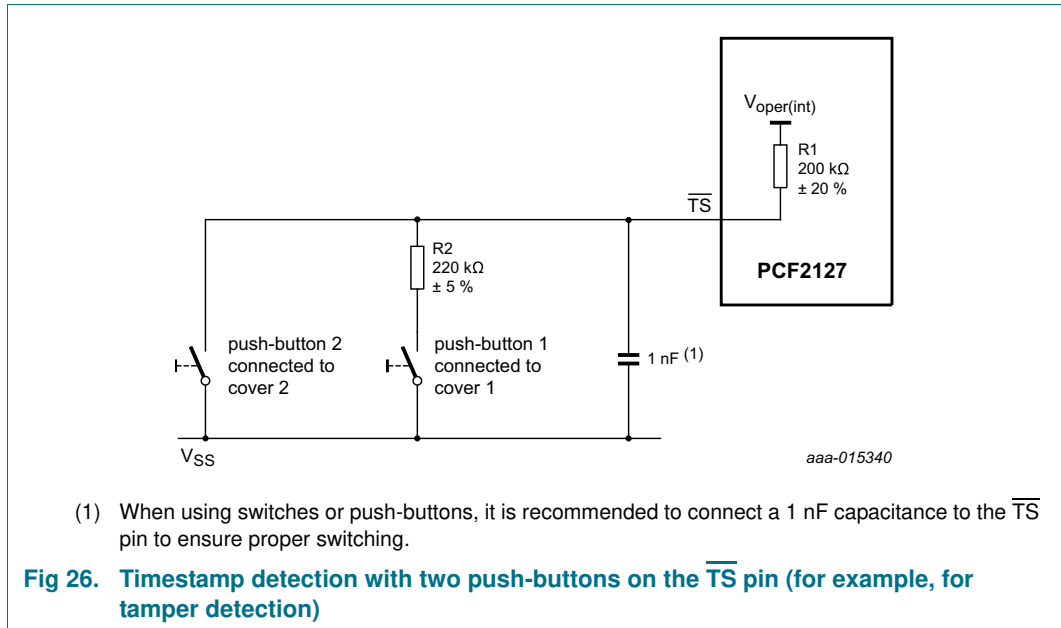

The timestamp function is enabled by default after power-on and it can be switched off by setting the control bit TSOFF (register `Timestampctl`).

A most common application of the timestamp function is described in [Ref. 3 “AN11266”](#).

See [Section 8.13.6](#) for a description of interrupt generation from the timestamp function.

8.12.1 Timestamp flag

1. When the \overline{TS} input pin is driven to an intermediate level between the power supply and ground, either on the falling edge from V_{DD} or on the rising edge from ground, then the following sequence occurs:
 - a. The actual date and time are stored in the timestamp registers.
 - b. The timestamp flag TSF1 (register `Control_1`) is set.
 - c. If the TSIE bit (register `Control_2`) is active, an interrupt on the \overline{INT} pin is generated.

The TSF1 flag can be cleared by command. Clearing the flag clears the interrupt. Once TSF1 is cleared, it will only be set again when a new negative or positive edge on pin \overline{TS} is detected.

2. When the \overline{TS} input pin is driven to ground, the following sequence occurs:
 - a. The actual date and time are stored in the timestamp registers.
 - b. In addition to the TSF1 flag, the TSF2 flag (register `Control_2`) is set.

c. If the TSIE bit is active, an interrupt on the $\overline{\text{INT}}$ pin is generated.

The TSF1 and TSF2 flags can be cleared by command; clearing both flags clears the interrupt. Once TSF2 is cleared, it will only be set again when $\overline{\text{TS}}$ pin is driven to ground once again.

8.12.2 Timestamp mode

The timestamp function has two different modes selected by the control bit TSM (timestamp mode) in register Timestp_ctl:

- If TSM is logic 0 (default): in subsequent trigger events without clearing the timestamp flags, the last timestamp event is stored
- If TSM is logic 1: in subsequent trigger events without clearing the timestamp flags, the first timestamp event is stored

The timestamp function also depends on the control bit BTSE in register Control_3, see [Section 8.12.4](#).

8.12.3 Timestamp registers

8.12.3.1 Register Timestp_ctl

Table 67. Timestp_ctl - timestamp control register (address 12h) bit allocation

Bit positions labeled as - are not implemented and return 0 when read. Bits labeled as X are undefined at power-on and unchanged by subsequent resets.

Bit	7	6	5	4	3	2	1	0
Symbol	TSM	TSOFF	-	1_O_16_TIMESTP[4:0]				
Reset value	0	0	-	X	X	X	X	X

Table 68. Timestp_ctl - timestamp control register (address 12h) bit description

Bit positions labeled as - are not implemented and return 0 when read. Bits labeled as X are undefined at power-on and unchanged by subsequent resets.

Bit	Symbol	Value	Description
7	TSM	0	in subsequent events without clearing the timestamp flags, the last event is stored
		1	in subsequent events without clearing the timestamp flags, the first event is stored
6	TSOFF	0	timestamp function active
		1	timestamp function disabled
5	-	-	unused
4 to 0	1_O_16_TIMESTP[4:0]		$\frac{1}{16}$ second timestamp information coded in BCD format

8.12.3.2 Register Sec_timestp

Table 69. Sec_timestp - second timestamp register (address 13h) bit allocation

Bit positions labeled as - are not implemented and return 0 when read. Bits labeled as X are undefined at power-on and unchanged by subsequent resets.

Bit	7	6	5	4	3	2	1	0
Symbol	-	SECOND_TIMESTP (0 to 59)						
Reset value	-	X	X	X	X	X	X	X

Table 70. Sec_timestp - second timestamp register (address 13h) bit description

Bit positions labeled as - are not implemented and return 0 when read. Bits labeled as X are undefined at power-on and unchanged by subsequent resets.

Bit	Symbol	Value	Place value	Description
7	-	-	-	unused
6 to 4	SECOND_TIMESTP	0 to 5	ten's place	second timestamp information coded in BCD format
3 to 0		0 to 9	unit place	

8.12.3.3 Register Min_timestp

Table 71. Min_timestp - minute timestamp register (address 14h) bit allocation

Bit positions labeled as - are not implemented and return 0 when read. Bits labeled as X are undefined at power-on and unchanged by subsequent resets.

Bit	7	6	5	4	3	2	1	0
Symbol	-	MINUTE_TIMESTP (0 to 59)						
Reset value	-	X	X	X	X	X	X	X

Table 72. Min_timestp - minute timestamp register (address 14h) bit description

Bit positions labeled as - are not implemented and return 0 when read. Bits labeled as X are undefined at power-on and unchanged by subsequent resets.

Bit	Symbol	Value	Place value	Description
7	-	-	-	unused
6 to 4	MINUTE_TIMESTP	0 to 5	ten's place	minute timestamp information coded in BCD format
3 to 0		0 to 9	unit place	

8.12.3.4 Register Hour_timestp

Table 73. Hour_timestp - hour timestamp register (address 15h) bit allocation

Bit positions labeled as - are not implemented and return 0 when read. Bits labeled as X are undefined at power-on and unchanged by subsequent resets.

Bit	7	6	5	4	3	2	1	0
Symbol	-	-	AMPM	HOUR_TIMESTP (1 to 12) in 12-hour mode				
				HOUR_TIMESTP (0 to 23) in 24-hour mode				
Reset value	-	-	X	X	X	X	X	X

Table 74. Hour_timestp - hour timestamp register (address 15h) bit description

Bit positions labeled as - are not implemented and return 0 when read. Bits labeled as X are undefined at power-on and unchanged by subsequent resets.

Bit	Symbol	Value	Place value	Description
7 to 6	-	-	-	unused
12-hour mode^[1]				
5	AMPM	0	-	indicates AM
		1	-	indicates PM
4	HOUR_TIMESTP	0 to 1	ten's place	hour timestamp information coded in BCD format when in 12-hour mode
3 to 0		0 to 9	unit place	
24-hour mode^[1]				
5 to 4	HOUR_TIMESTP	0 to 2	ten's place	hour timestamp information coded in BCD format when in 24-hour mode
3 to 0		0 to 9	unit place	

[1] Hour mode is set by the bit 12_24 in register Control_1.

8.12.3.5 Register Day_timestp

Table 75. Day_timestp - day timestamp register (address 16h) bit allocation

Bit positions labeled as - are not implemented and return 0 when read. Bits labeled as X are undefined at power-on and unchanged by subsequent resets.

Bit	7	6	5	4	3	2	1	0
Symbol	-	-	DAY_TIMESTP (1 to 31)					
Reset value	-	-	X	X	X	X	X	X

Table 76. Day_timestp - day timestamp register (address 16h) bit description

Bit positions labeled as - are not implemented and return 0 when read. Bits labeled as X are undefined at power-on and unchanged by subsequent resets.

Bit	Symbol	Value	Place value	Description
7 to 6	-	-	-	unused
5 to 4	DAY_TIMESTP	0 to 3	ten's place	day timestamp information coded in BCD format
3 to 0		0 to 9	unit place	

8.12.3.6 Register Mon_timestp

Table 77. Mon_timestp - month timestamp register (address 17h) bit allocation

Bit positions labeled as - are not implemented and return 0 when read. Bits labeled as X are undefined at power-on and unchanged by subsequent resets.

Bit	7	6	5	4	3	2	1	0
Symbol	-	-	-	MONTH_TIMESTP (1 to 12)				
Reset value	-	-	-	X	X	X	X	X

Table 78. Mon_timestp - month timestamp register (address 17h) bit description

Bit positions labeled as - are not implemented and return 0 when read. Bits labeled as X are undefined at power-on and unchanged by subsequent resets.

Bit	Symbol	Value	Place value	Description
7 to 5	-	-	-	unused
4	MONTH_TIMESTP	0 to 1	ten's place	month timestamp information coded in BCD format
3 to 0		0 to 9	unit place	

8.12.3.7 Register Year_timestp

Table 79. Year_timestp - year timestamp register (address 18h) bit allocation

Bits labeled as X are undefined at power-on and unchanged by subsequent resets.

Bit	7	6	5	4	3	2	1	0
Symbol	YEAR_TIMESTP (0 to 99)							
Reset value	X	X	X	X	X	X	X	X

Table 80. Year_timestp - year timestamp register (address 18h) bit description

Bits labeled as X are undefined at power-on and unchanged by subsequent resets.

Bit	Symbol	Value	Place value	Description
7 to 4	YEAR_TIMESTP	0 to 9	ten's place	year timestamp information coded in BCD format
3 to 0		0 to 9	unit place	

8.12.4 Dependency between Battery switch-over and timestamp

The timestamp function depends on the control bit BTSE in register Control_3:

Table 81. Battery switch-over and timestamp

BTSE	BF	Description
0	-	[1] the battery switch-over does not affect the timestamp registers
1	0	[1] If a battery switch-over event occurs: the timestamp registers store the time and date when the switch-over occurs; after this event occurred BF is set logic 1
	1	the timestamp registers are not modified; in this condition subsequent battery switch-over events or falling edges on pin \overline{TS} are not registered

[1] Default value.

8.13 Interrupt output, $\overline{\text{INT}}$

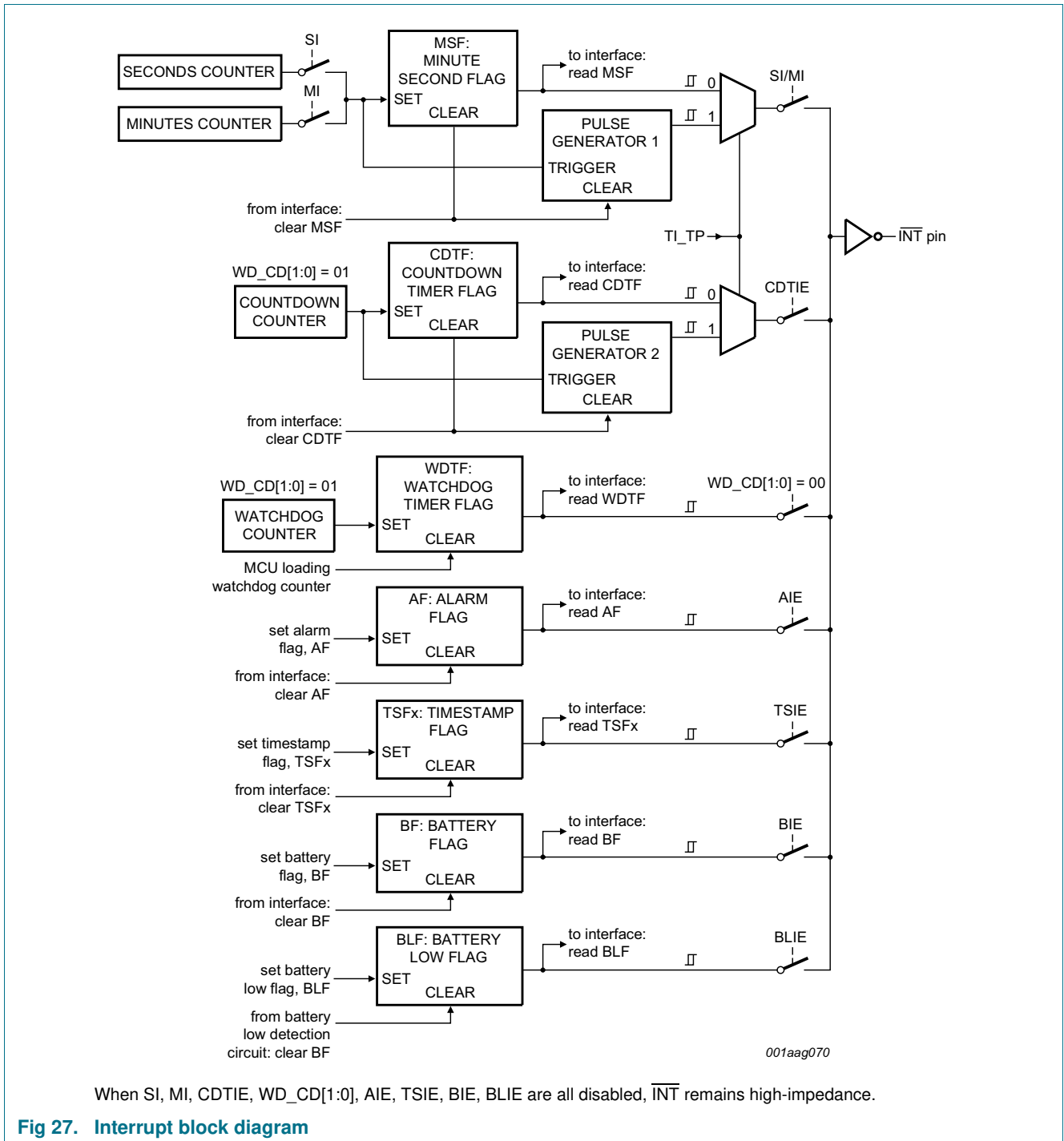

Fig 27. Interrupt block diagram

PCF2127 has an interrupt output pin $\overline{\text{INT}}$ which is open-drain, active LOW (requiring a pull-up resistor if used). Interrupts may be sourced from different places:

- second or minute timer
- countdown timer

- watchdog timer
- alarm
- timestamp
- battery switch-over
- battery low detection

The control bit TI_TP (register Watchdg_tim_ctl) is used to configure whether the interrupts generated from the second/minute timer (flag MSF in register Control_2) and the countdown timer (flag CDTF in register Control_2) are pulsed signals or a permanently active signal. All the other interrupt sources generate a permanently active interrupt signal which follows the status of the corresponding flags. When the interrupt sources are all disabled, $\overline{\text{INT}}$ remains high-impedance.

- The flags MSF, CDTF, AF, TSFx, and BF can be cleared by command.
- The flag WDTF is read only. How it can be cleared is explained in [Section 8.11.6](#).
- The flag BLF is read only. It is cleared automatically from the battery low detection circuit when the battery is replaced.

8.13.1 Minute and second interrupts

Minute and second interrupts are generated by predefined timers. The timers can be enabled independently from one another by the bits MI and SI in register Control_1. However, a minute interrupt enabled on top of a second interrupt cannot be distinguishable since it occurs at the same time.

The minute/second flag MSF (register Control_2) is set logic 1 when either the seconds or the minutes counter increments according to the enabled interrupt (see [Table 82](#)). The MSF flag can be cleared by command.

Table 82. Effect of bits MI and SI on pin $\overline{\text{INT}}$ and bit MSF

MI	SI	Result on $\overline{\text{INT}}$	Result on MSF
0	0	no interrupt generated	MSF never set
1	0	an interrupt once per minute	MSF set when minutes counter increments
0	1	an interrupt once per second	MSF set when seconds counter increments
1	1	an interrupt once per second	MSF set when seconds counter increments

When MSF is set logic 1:

- If TI_TP is logic 1, the interrupt is generated as a pulsed signal.
- If TI_TP is logic 0, the interrupt is permanently active signal that remains until MSF is cleared.

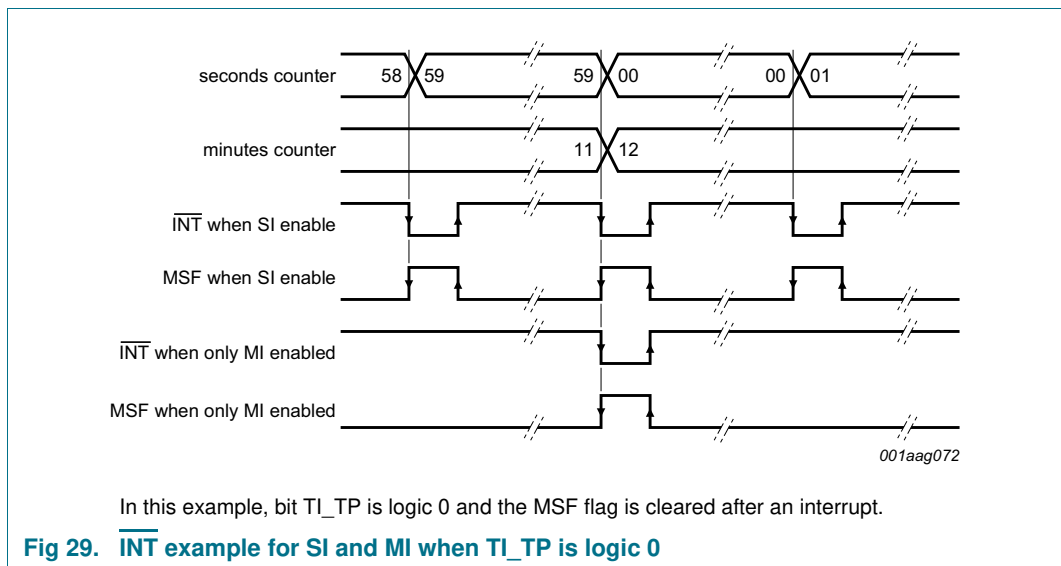
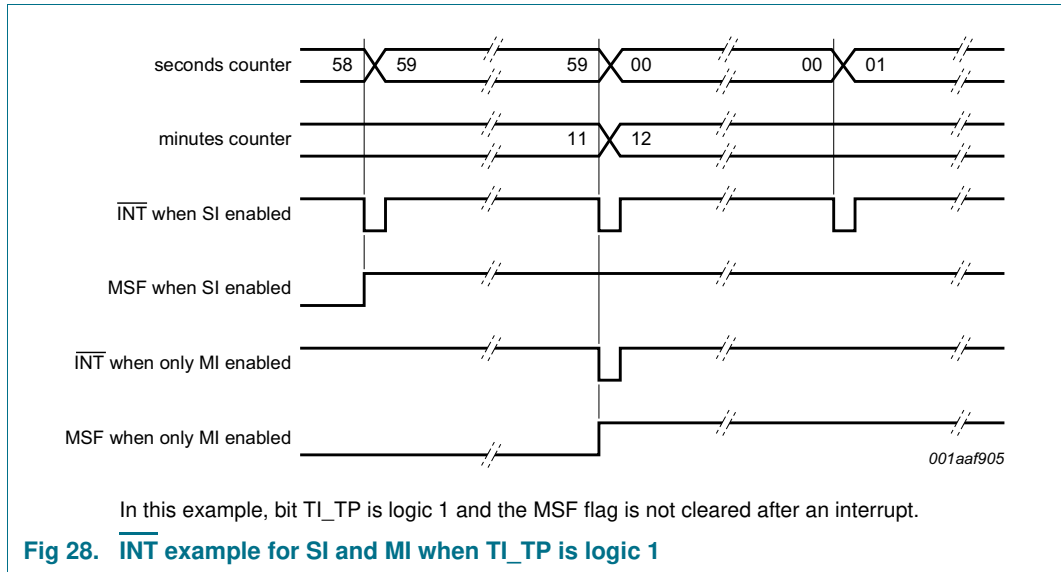

The pulse generator for the minute/second interrupt operates from an internal 64 Hz clock and generates a pulse of $\frac{1}{64}$ seconds in duration.

8.13.2 Countdown timer interrupts

The generation of interrupts from the countdown timer is controlled by the CDTIE bit (register Control_2).

The interrupt may be generated as a pulsed signal at every countdown period or as a permanently active signal which follows the status of the countdown timer flag CDTF. Bit TI_TP is used to control this bit.

8.13.3 $\overline{\text{INT}}$ pulse shortening

The pulse generator for the countdown timer interrupt also uses an internal clock, but this time it is dependent on the selected source clock for the countdown timer and on the countdown value n. As a consequence, the width of the interrupt pulse varies (see

Table 83).

Table 83. $\overline{\text{INT}}$ operation (bit TI_TP = 1)

Source clock (Hz)	$\overline{\text{INT}}$ period (s)	
	n = 1 ^[1]	n > 1
4096	$\frac{1}{8192}$	$\frac{1}{4096}$
64	$\frac{1}{128}$	$\frac{1}{64}$
1	$\frac{1}{64}$	$\frac{1}{64}$
$\frac{1}{60}$	$\frac{1}{64}$	$\frac{1}{64}$

[1] n = loaded countdown value. Timer stopped when n = 0.

If the MSF or CDTF flag (register Control_2) is cleared before the end of the $\overline{\text{INT}}$ pulse, then the $\overline{\text{INT}}$ pulse is shortened. This allows the source of a system interrupt to be cleared immediately when it is serviced, that is, the system does not have to wait for the completion of the pulse before continuing, see Figure 30 and Figure 31. Instructions for clearing bit MSF and bit CDTF can be found in Section 8.11.6.

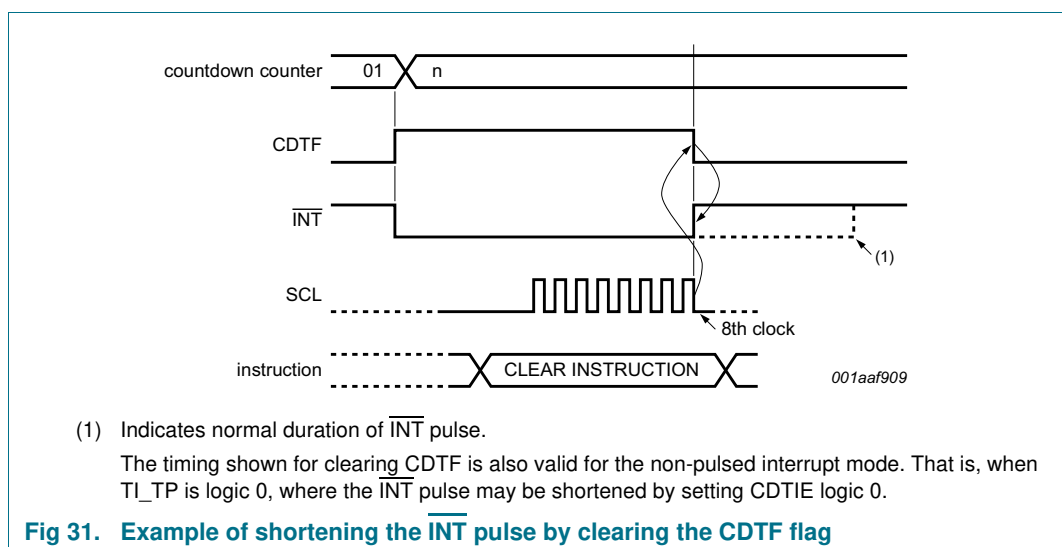
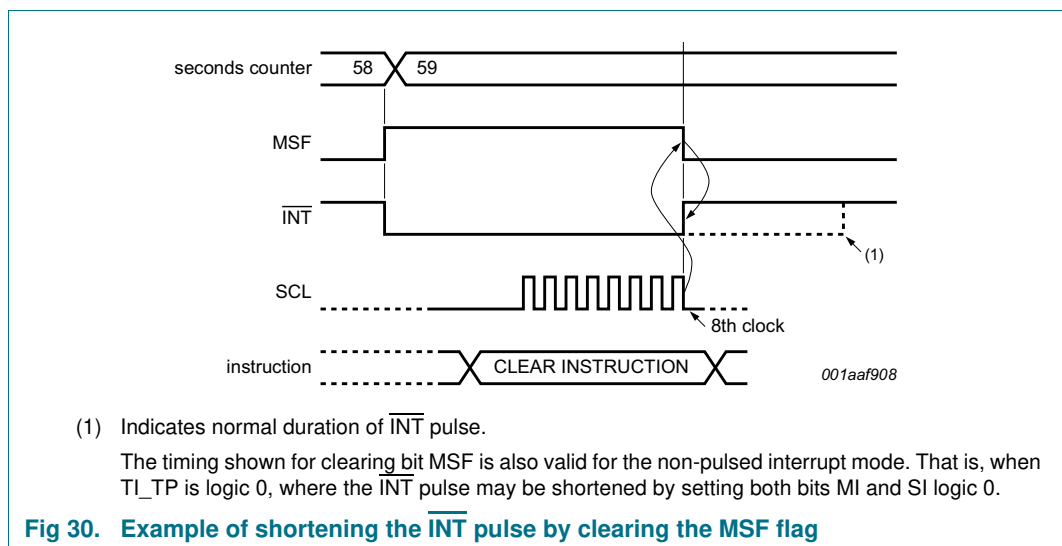

8.13.4 Watchdog timer interrupts

The generation of interrupts from the watchdog timer is controlled using the WD_CD[1:0] bits (register Watchdog_tim_ctl). The interrupt is generated as an active signal which follows the status of the watchdog timer flag WDTF (register Control_2). No pulse generation is possible for watchdog timer interrupts.

The interrupt is cleared when the flag WDTF is reset. WDTF is a read-only bit and cannot be cleared by command. Instructions for clearing it can be found in [Section 8.11.6](#).

8.13.5 Alarm interrupts

Generation of interrupts from the alarm function is controlled by the bit AIE (register Control_2). If AIE is enabled, the $\overline{\text{INT}}$ pin follows the status of bit AF (register Control_2). Clearing AF immediately clears $\overline{\text{INT}}$. No pulse generation is possible for alarm interrupts.

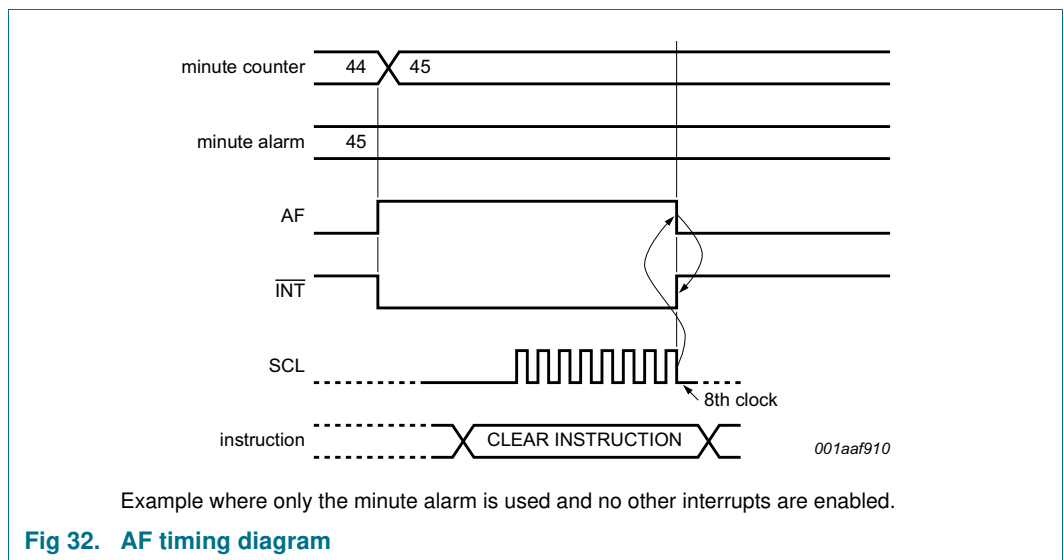

8.13.6 Timestamp interrupts

Interrupt generation from the timestamp function is controlled using the TSIE bit (register Control_2). If TSIE is enabled, the $\overline{\text{INT}}$ pin follows the status of the flags TSFx. Clearing the flags TSFx immediately clears $\overline{\text{INT}}$. No pulse generation is possible for timestamp interrupts.

8.13.7 Battery switch-over interrupts

Generation of interrupts from the battery switch-over is controlled by the BIE bit (register Control_3). If BIE is enabled, the $\overline{\text{INT}}$ pin follows the status of bit BF in register Control_3 (see [Table 81](#)). Clearing BF immediately clears $\overline{\text{INT}}$. No pulse generation is possible for battery switch-over interrupts.

8.13.8 Battery low detection interrupts

Generation of interrupts from the battery low detection is controlled by the BLIE bit (register Control_3). If BLIE is enabled, the $\overline{\text{INT}}$ pin follows the status of bit BLF (register Control_3). The interrupt is cleared when the battery is replaced (BLF is logic 0) or when bit BLIE is disabled (BLIE is logic 0). BLF is read only and therefore cannot be cleared by command.

8.14 External clock test mode

A test mode is available which allows on-board testing. In this mode, it is possible to set up test conditions and control the operation of the RTC.

The test mode is entered by setting bit EXT_TEST logic 1 (register Control_1). Then pin CLKOUT becomes an input. The test mode replaces the internal clock signal (64 Hz) with the signal applied to pin CLKOUT. Every 64 positive edges applied to pin CLKOUT generate an increment of one second.

The signal applied to pin CLKOUT should have a minimum pulse width of 300 ns and a maximum period of 1000 ns. The internal clock, now sourced from CLKOUT, is divided down by a 2^6 divider chain called prescaler (see [Table 84](#)). The prescaler can be set into a known state by using bit STOP. When bit STOP is logic 1, the prescaler is reset to 0. STOP must be cleared before the prescaler can operate again.

From a stop condition, the first 1 second increment will take place after 32 positive edges on pin CLKOUT. Thereafter, every 64 positive edges cause a 1 second increment.

Remark: Entry into test mode is not synchronized to the internal 64 Hz clock. When entering the test mode, no assumption as to the state of the prescaler can be made.

Operating example:

1. Set EXT_TEST test mode (register Control_1, EXT_TEST is logic 1).
2. Set bit STOP (register Control_1, STOP is logic 1).
3. Set time registers to desired value.
4. Clear STOP (register Control_1, STOP is logic 0).
5. Apply 32 clock pulses to CLKOUT.
6. Read time registers to see the first change.
7. Apply 64 clock pulses to CLKOUT.
8. Read time registers to see the second change.

Repeat 7 and 8 for additional increments.

8.15 STOP bit function

The function of the STOP bit is to allow for accurate starting of the time circuits. STOP causes the upper part of the prescaler (F_9 to F_{14}) to be held in reset and thus no 1 Hz ticks are generated. The time circuits can then be set and will not increment until the STOP bit is released. STOP doesn't affect the CLKOUT signal but the output of the prescaler in the range of 32 Hz to 1 Hz (see [Figure 33](#)).

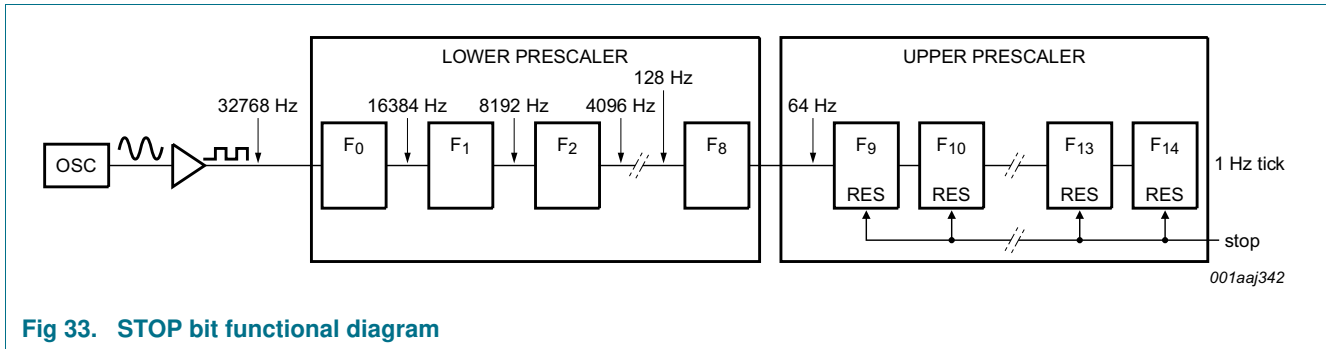

The lower stages of the prescaler, F_0 to F_8 , are not reset and because the I²C-bus and the SPI-bus are asynchronous to the crystal oscillator, the accuracy of restarting the time circuits is between 0 and one 64 Hz cycle (0.484375 s and 0.500000 s), see [Table 84](#) and [Figure 34](#).

Table 84. First increment of time circuits after stop release

Bit STOP	Prescaler bits ^[1] F_0 to F_8 - F_9 to F_{14}	1 Hz tick	Time hh:mm:ss	Comment
Clock is running normally				
0	010000111-010100		12:45:12	prescaler counting normally
STOP bit is activated by user. F_0 to F_8 are not reset and values cannot be predicted externally				
1	xxxxxxxx-000000		12:45:12	prescaler is reset; time circuits are frozen
New time is set by user				
1	xxxxxxxx-000000		08:00:00	prescaler is reset; time circuits are frozen
STOP bit is released by user				
0	xxxxxxxx-000000		08:00:00	prescaler is now running
0	xxxxxxxx-100000		08:00:00	
0	xxxxxxxx-100000		08:00:00	
0	xxxxxxxx-110000		08:00:00	
:	:		:	
0	11111111-111110		08:00:00	
0	00000000-000001		08:00:01	0 to 1 transition of F_{14} increments the time circuits
0	10000000-000001		08:00:01	
:	:		:	
0	11111111-111111		08:00:01	
0	00000000-000000		08:00:01	
0	10000000-000000			
:	:		:	
0	11111111-111110		08:00:01	
0	00000000-000001		08:00:02	0 to 1 transition of F_{14} increments the time circuits

[1] F_0 is clocked at 32.768 kHz.

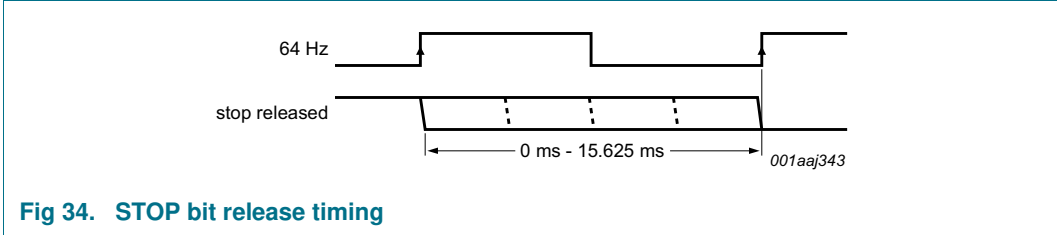

Fig 34. STOP bit release timing

9. Interfaces

The PCF2127 has an I²C-bus or SPI-bus interface using the same pins. The selection is done using the interface selection pin IFS (see [Table 85](#)).

Table 85. Interface selection input pin IFS

Pin	Connection	Bus interface	Reference
IFS	V _{SS}	SPI-bus	Section 9.1
	BBS	I ² C-bus	Section 9.2

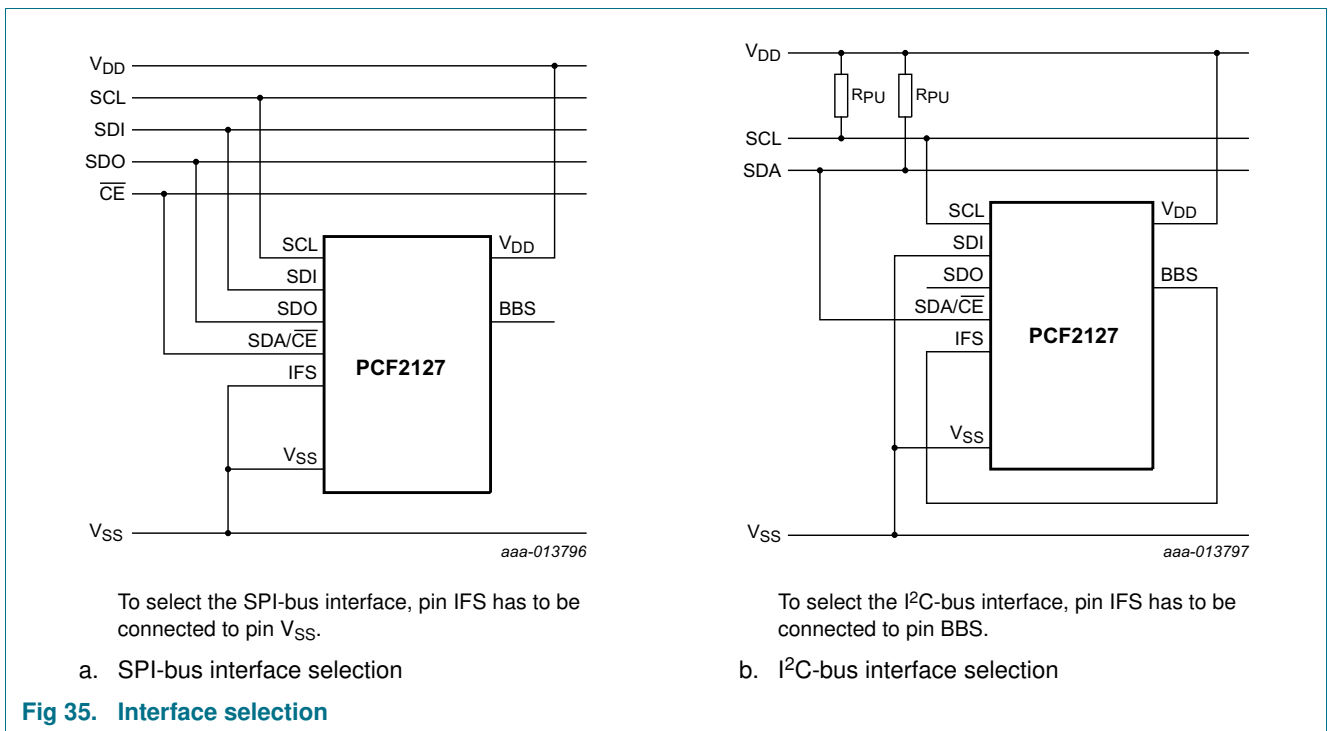

9.1 SPI-bus interface

Data transfer to and from the device is made by a 3 line SPI-bus (see [Table 86](#)). The data lines for input and output are split. The data input and output line can be connected together to facilitate a bidirectional data bus (see [Figure 36](#)). The SPI-bus is initialized whenever the chip enable line pin SDA/CE is inactive.

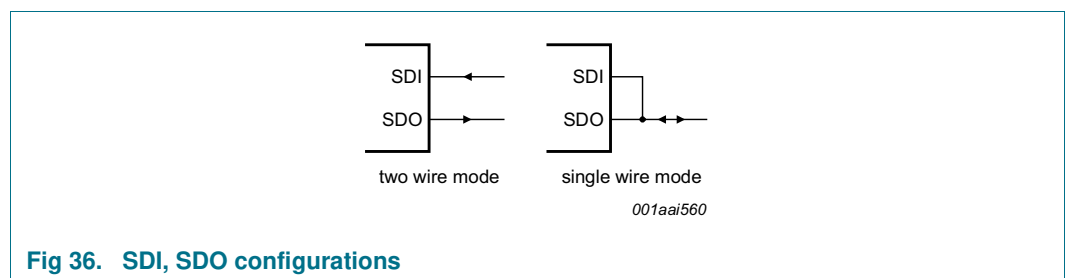

Table 86. Serial interface

Symbol	Function	Description
SDA/ $\overline{\text{CE}}$	chip enable input; active LOW	[1] when HIGH, the interface is reset; input may be higher than V_{DD}
SCL	serial clock input	when SDA/ $\overline{\text{CE}}$ is HIGH, input may float; input may be higher than V_{DD}
SDI	serial data input	when SDA/ $\overline{\text{CE}}$ is HIGH, input may float; input may be higher than V_{DD} ; input data is sampled on the rising edge of SCL
SDO	serial data output	push-pull output; drives from V_{SS} to $V_{oper(int)}$ (V_{BBS}); output data is changed on the falling edge of SCL

[1] The chip enable must not be wired permanently LOW.

9.1.1 Data transmission

The chip enable signal is used to identify the transmitted data. Each data transfer is a whole byte, with the Most Significant Bit (MSB) sent first.

The transmission is controlled by the active LOW chip enable signal SDA/ $\overline{\text{CE}}$. The first byte transmitted is the command byte. Subsequent bytes are either data to be written or data to be read (see [Figure 37](#)).

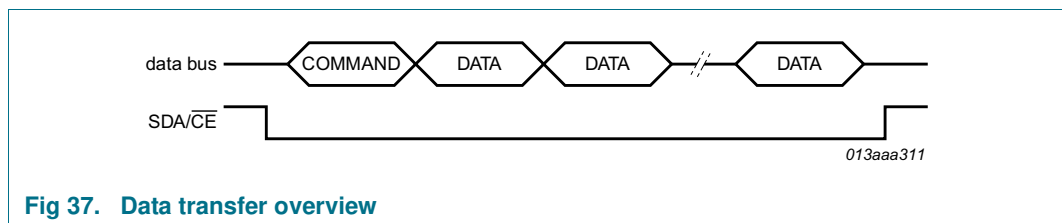
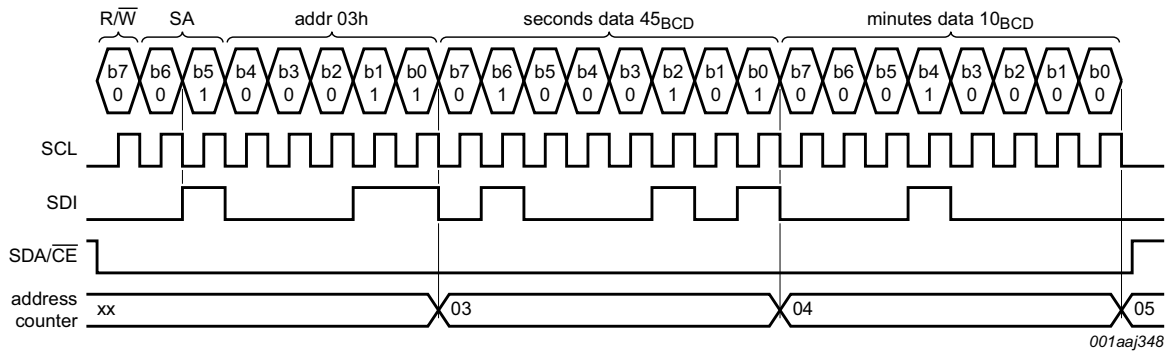

Fig 37. Data transfer overview

The command byte defines the address of the first register to be accessed and the read/write mode. The address counter will auto increment after every access and will reset to zero after the last valid register is accessed. The $\overline{\text{R/W}}$ bit defines if the following bytes are read or write information.

Table 87. Command byte definition

Bit	Symbol	Value	Description
7	$\overline{\text{R/W}}$		data read or write selection
		0	write data
		1	read data
6 to 5	SA	01	subaddress; other codes will cause the device to ignore data transfer
4 to 0	RA	00h to 1Dh	register address



In this example, the Seconds register is set to 45 seconds and the Minutes register to 10 minutes.

a. Writing seconds and minutes

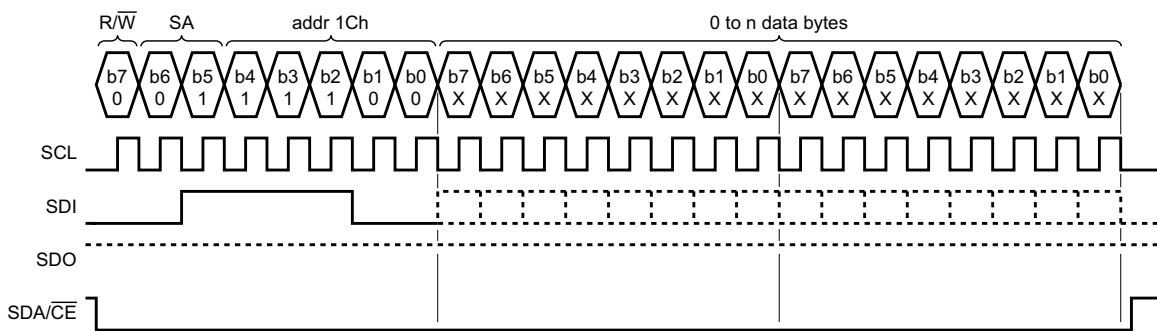
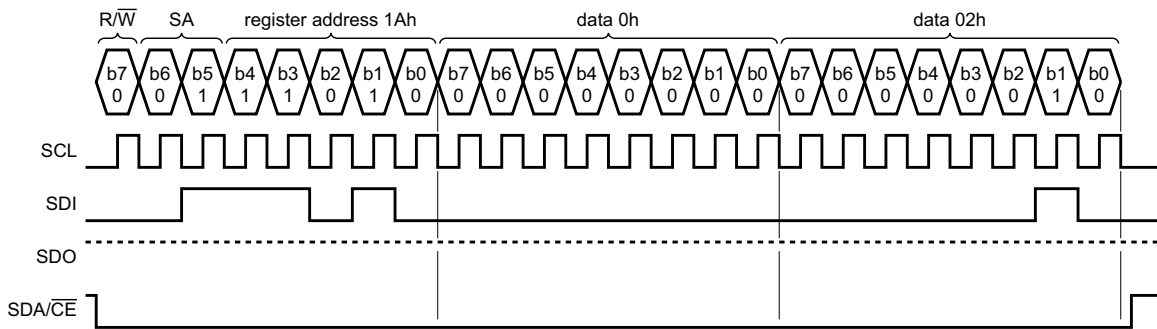

aaa-014443

b. Writing to RAM address 02h

Fig 38. SPI-bus write examples

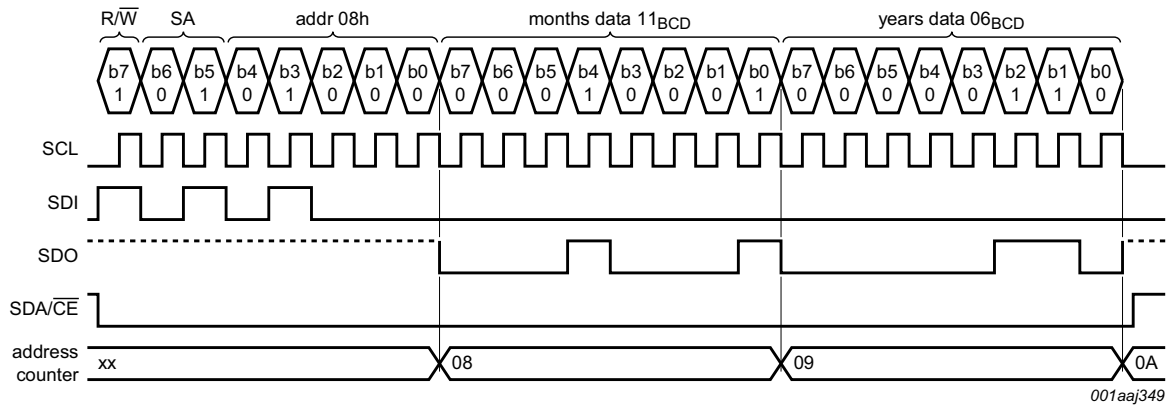

In this example, the registers Months and Years are read. The pins SDI and SDO are not connected together. For this configuration, it is important that pin SDI is never left floating. It must always be driven either HIGH or LOW. If pin SDI is left open, high I_{DD} currents may result.

a. Reading month and year

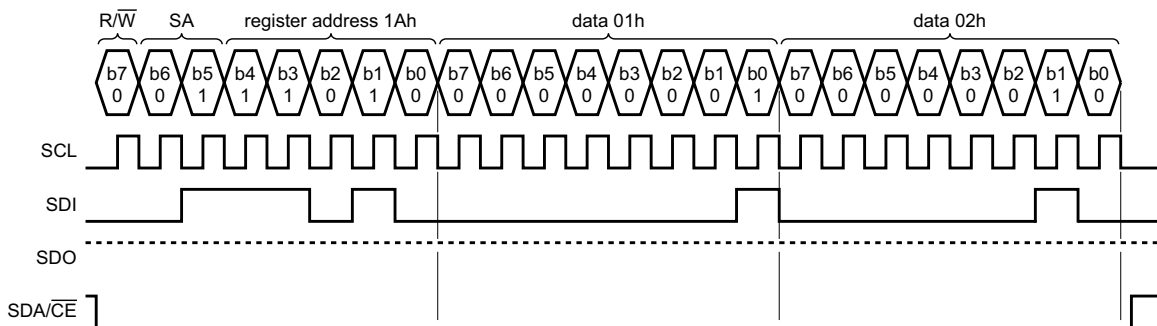

b. Reading from RAM address 12h

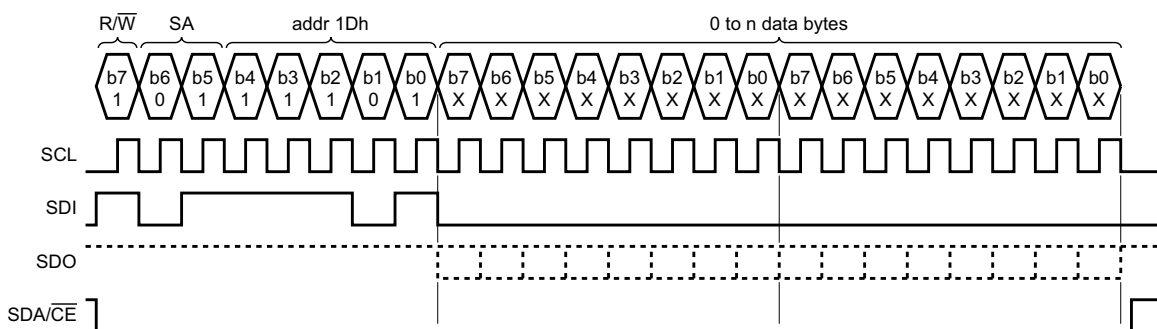

Fig 39. SPI-bus read examples

9.2 I²C-bus interface

The I²C-bus is for bidirectional, two-line communication between different ICs or modules. The two lines are a Serial Data line (SDA) and a Serial Clock line (SCL). Both lines are connected to a positive supply by a pull-up resistor. Data transfer is initiated only when the bus is not busy.

9.2.1 Bit transfer

One data bit is transferred during each clock pulse. The data on the SDA line remains stable during the HIGH period of the clock pulse as changes in the data line at this time are interpreted as control signals (see [Figure 40](#)).

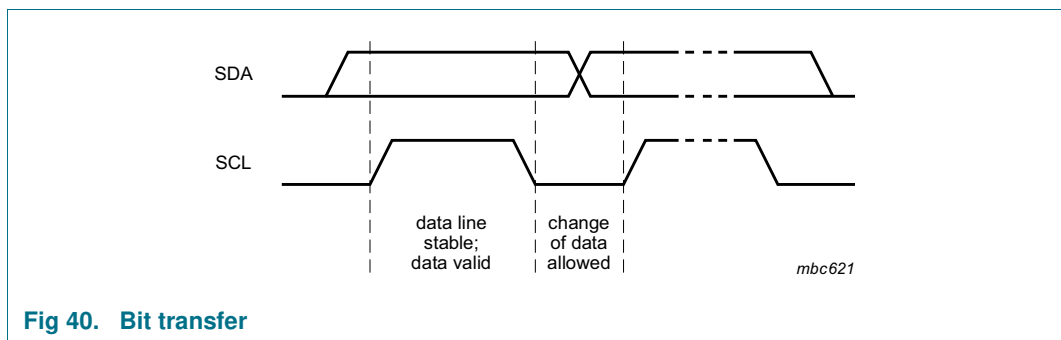

Fig 40. Bit transfer

9.2.2 START and STOP conditions

Both data and clock lines remain HIGH when the bus is not busy. A HIGH-to-LOW transition of the data line, while the clock is HIGH, is defined as the START condition S. A LOW-to-HIGH transition of the data line while the clock is HIGH is defined as the STOP condition P (see [Figure 41](#)).

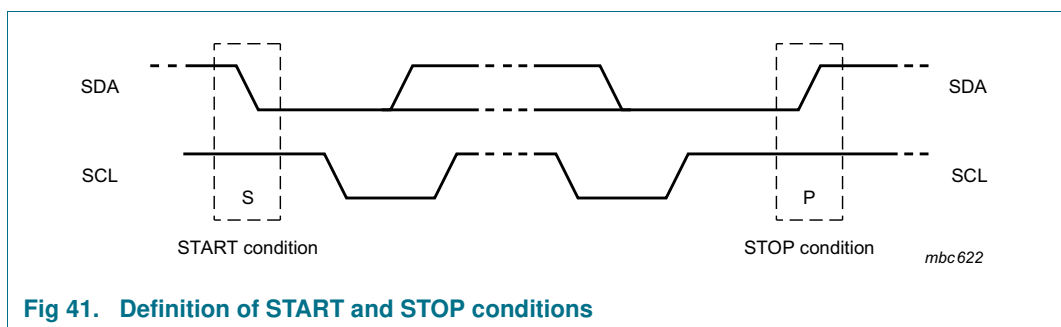

Fig 41. Definition of START and STOP conditions

Remark: For the PCF2127, a repeated START is not allowed. Therefore a STOP has to be released before the next START.

9.2.3 System configuration

A device generating a message is a transmitter; a device receiving a message is the receiver. The device that controls the message is the master; and the devices which are controlled by the master are the slaves.

The PCF2127 can act as a slave transmitter and a slave receiver.

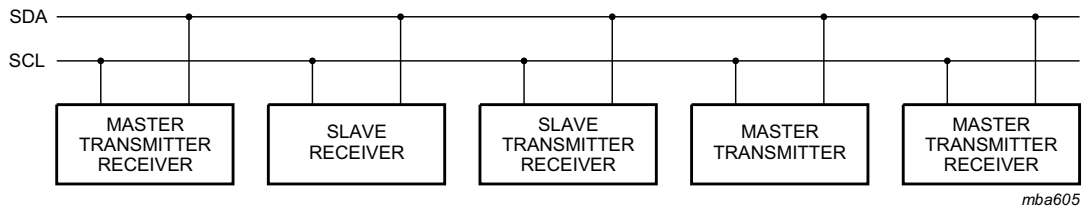

Fig 42. System configuration

9.2.4 Acknowledge

The number of data bytes transferred between the START and STOP conditions from transmitter to receiver is unlimited. Each byte of eight bits is followed by an acknowledge cycle.

- A slave receiver which is addressed must generate an acknowledge after the reception of each byte.
- Also a master receiver must generate an acknowledge after the reception of each byte that has been clocked out of the slave transmitter.
- The device that acknowledges must pull-down the SDA line during the acknowledge clock pulse, so that the SDA line is stable LOW during the HIGH period of the acknowledge related clock pulse (set-up and hold times must be considered).
- A master receiver must signal an end of data to the transmitter by not generating an acknowledge on the last byte that has been clocked out of the slave. In this event, the transmitter must leave the data line HIGH to enable the master to generate a STOP condition.

Acknowledgement on the I2C-bus is illustrated in [Figure 43](#).

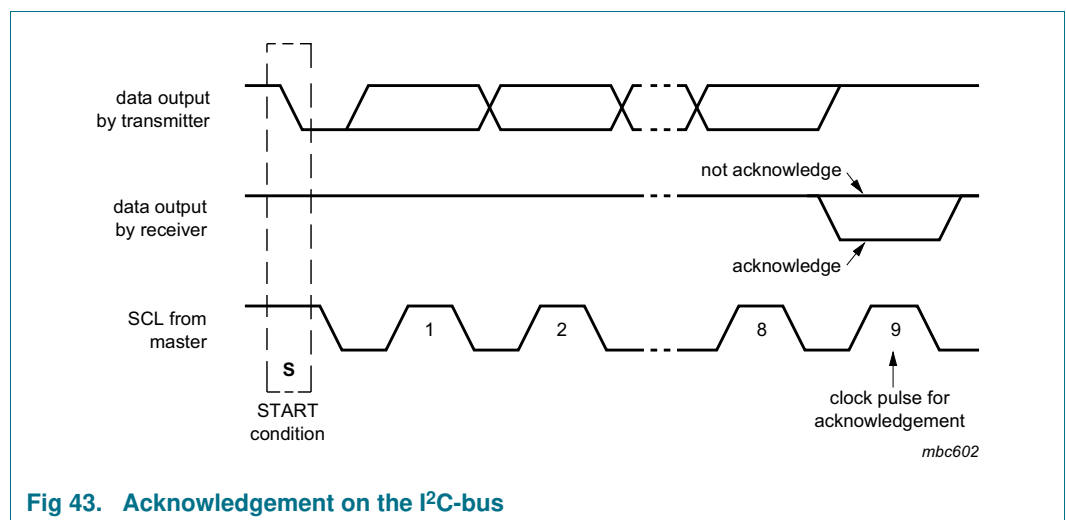

Fig 43. Acknowledgement on the I2C-bus

9.2.5 I2C-bus protocol

After a start condition, a valid hardware address has to be sent to a PCF2127 device. The appropriate I2C-bus slave address is 1010001. The entire I2C-bus slave address byte is shown in [Table 88](#).

Table 88. I²C slave address byte

		Slave address							
Bit	7	6	5	4	3	2	1	0	
	MSB							LSB	
	1	0	1	0	0	0	1	R/W	

The R/W bit defines the direction of the following single or multiple byte data transfer (read is logic 1, write is logic 0).

For the format and the timing of the START condition (S), the STOP condition (P), and the acknowledge (A) refer to the I²C-bus specification [Ref. 13 “UM10204”](#) and the characteristics table ([Table 93](#)). In the write mode, a data transfer is terminated by sending a STOP condition. A repeated START (Sr) condition is not applicable.

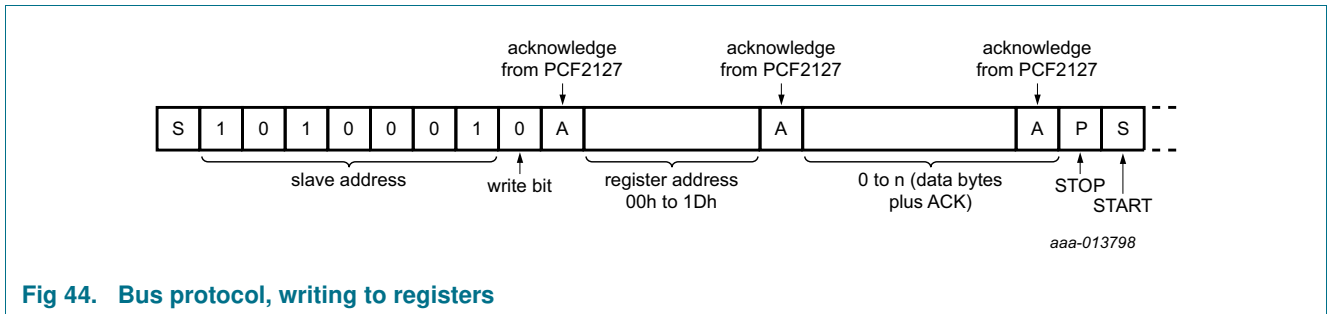

Fig 44. Bus protocol, writing to registers

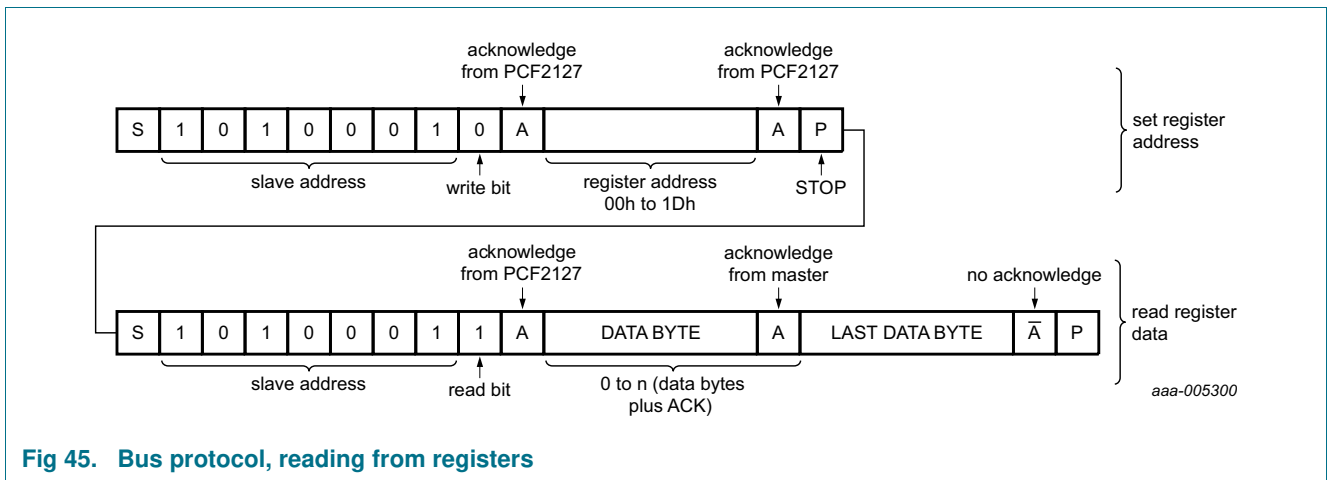

Fig 45. Bus protocol, reading from registers

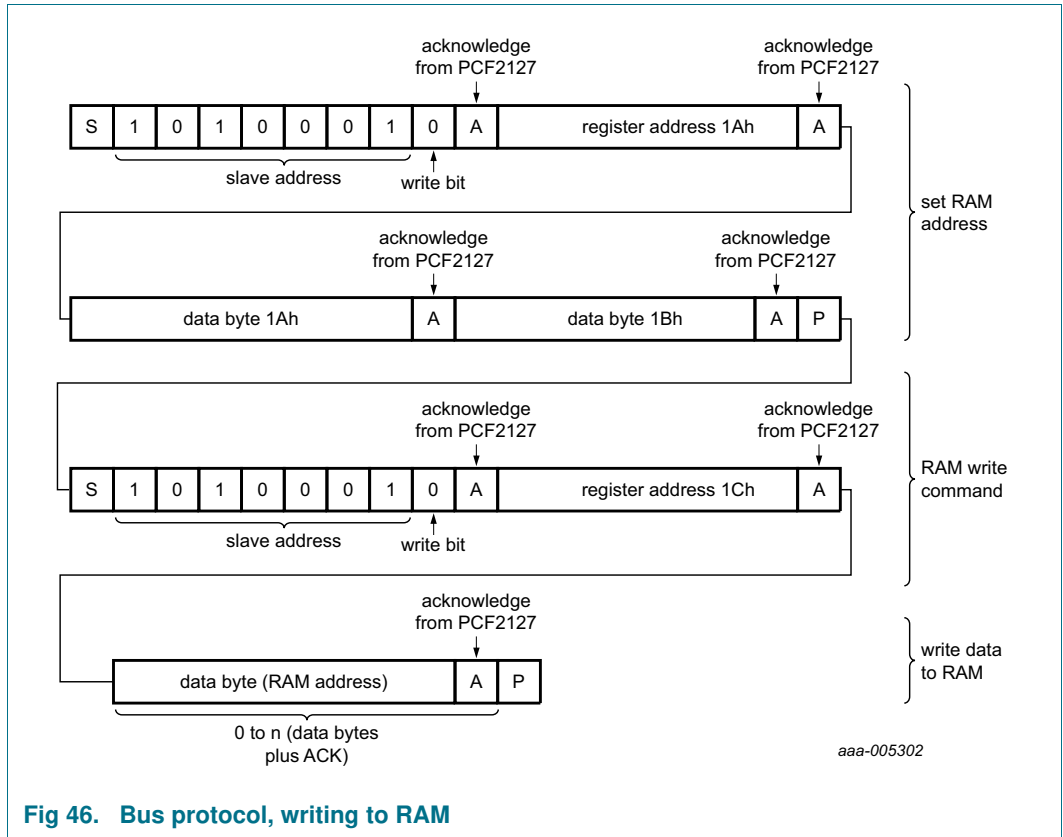

Fig 46. Bus protocol, writing to RAM

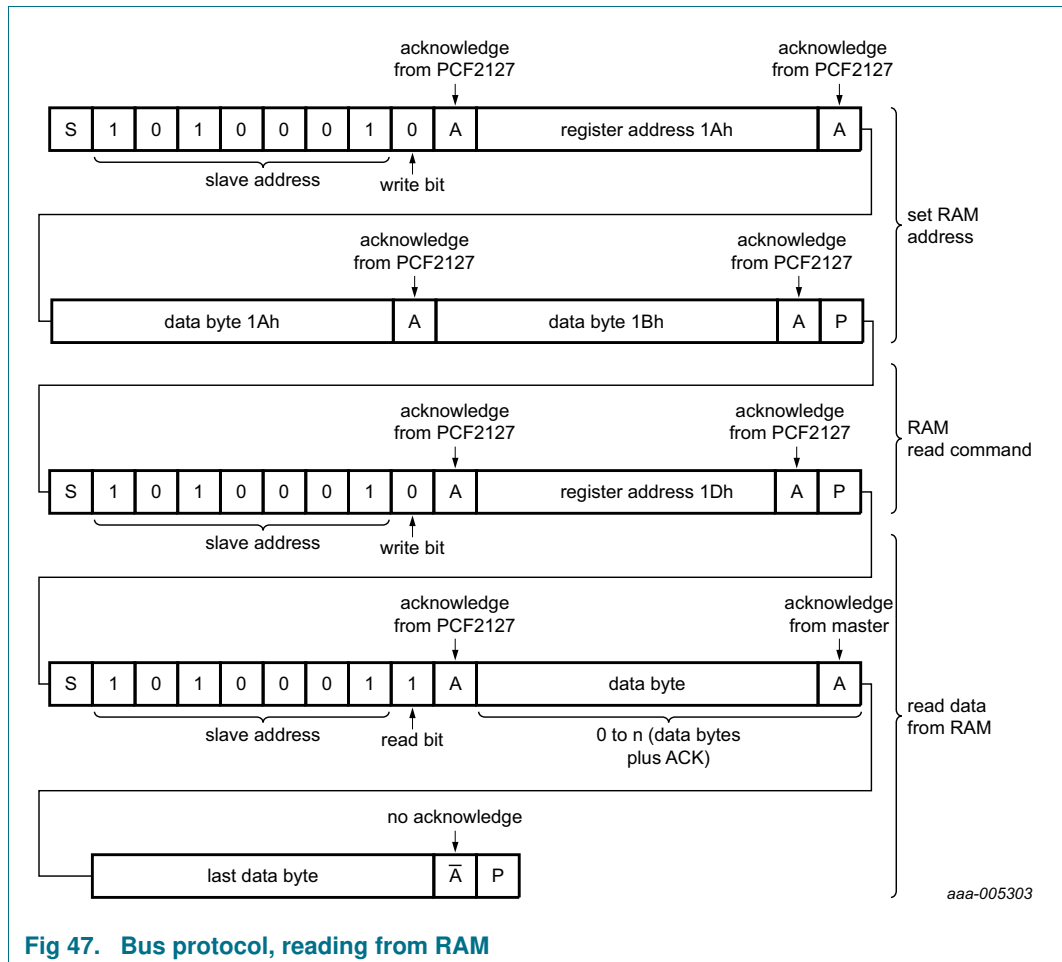

Fig 47. Bus protocol, reading from RAM

9.3 Bus communication and battery backup operation

To save power during battery backup operation (see [Section 8.6.1](#)), the bus interfaces are inactive. Therefore the communication via I²C- or SPI-bus should be terminated before the supply of the PCF2127 is switched from V_{DD} to V_{BAT}.

The extra power fail detection function (see [Section 8.6.3](#)) of the PCF2127 allows early detection of a dropping V_{DD}. The output on pin PFO indicates to the microcontroller to terminate the bus communication properly. When the bus communication is not terminated in a proper way, the time counters get corrupted.

Remark: If the I²C-bus communication was terminated uncontrolled, the I²C-bus has to be reinitialized by sending a STOP followed by a START after the device switched back from battery backup operation to V_{DD} supply operation.

10. Internal circuitry

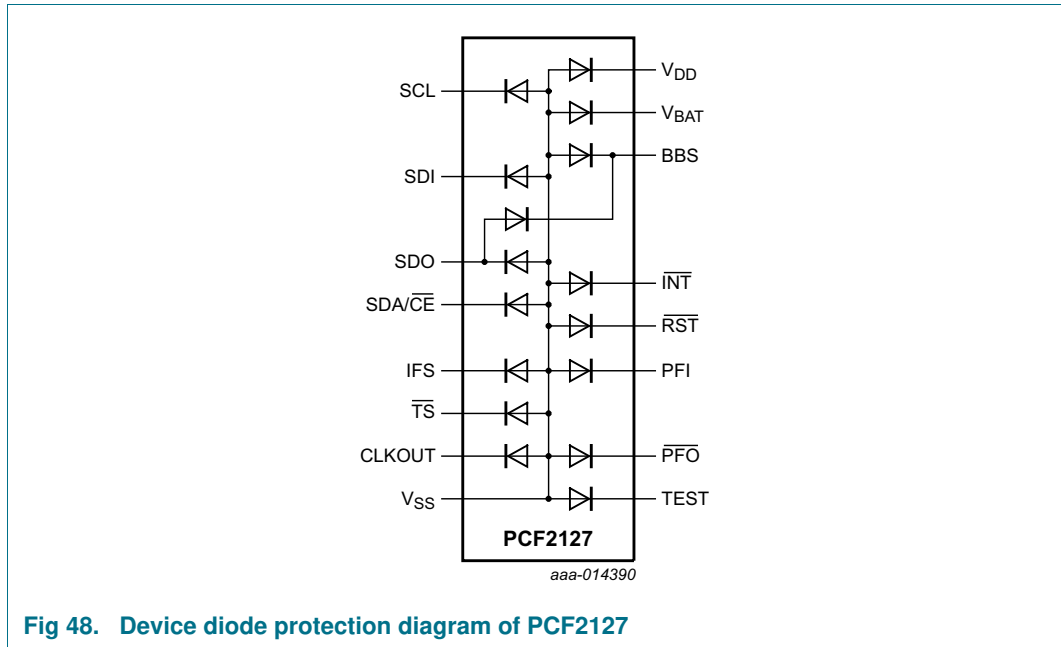

11. Safety notes

CAUTION



This device is sensitive to ElectroStatic Discharge (ESD). Observe precautions for handling electrostatic sensitive devices.

Such precautions are described in the *ANSI/ESD S20.20*, *IEC/ST 61340-5*, *JESD625-A* or equivalent standards.

12. Limiting values

Table 89. Limiting values

In accordance with the Absolute Maximum Rating System (IEC 60134).

Symbol	Parameter	Conditions	Min	Max	Unit	
V _{DD}	supply voltage		-0.5	+6.5	V	
I _{DD}	supply current		-50	+50	mA	
V _i	input voltage		-0.5	+6.5	V	
I _I	input current		-10	+10	mA	
V _O	output voltage		-0.5	+6.5	V	
I _O	output current		-10	+10	mA	
		at pin SDA/CE	-10	+20	mA	
V _{BAT}	battery supply voltage		-0.5	+6.5	V	
P _{tot}	total power dissipation		-	300	mW	
V _{ESD}	electrostatic discharge voltage	HBM [1]	-	±4000	V	
		CDM [2]	-	±1250	V	
I _{Iu}	latch-up current		[3]	200	mA	
T _{stg}	storage temperature		[4]	-55	+85	°C
T _{amb}	ambient temperature	operating device	-40	+85	°C	

[1] Pass level; Human Body Model (HBM) according to [Ref. 7 "JESD22-A114"](#).

[2] Pass level; Charged-Device Model (CDM), according to [Ref. 8 "JESD22-C101"](#).

[3] Pass level; latch-up testing according to [Ref. 9 "JESD78"](#) at maximum ambient temperature (T_{amb(max)}).

[4] According to the store and transport requirements (see [Ref. 14 "UM10569"](#)) the devices have to be stored at a temperature of +8 °C to +45 °C and a humidity of 25 % to 75 %.

13. Static characteristics

Table 90. Static characteristics

$V_{DD} = 1.8\text{ V to }4.2\text{ V}$; $V_{SS} = 0\text{ V}$; $T_{amb} = -40\text{ }^{\circ}\text{C to }+85\text{ }^{\circ}\text{C}$, unless otherwise specified.

Symbol	Parameter	Conditions	Min	Typ	Max	Unit	
Supplies							
V_{DD}	supply voltage	[1]	1.8	-	4.2	V	
V_{BAT}	battery supply voltage		1.8	-	4.2	V	
$V_{DD(cal)}$	calibration supply voltage		-	3.3	-	V	
V_{low}	low voltage		-	1.2	-	V	
I_{DD}	supply current	interface active; supplied by V_{DD}					
		SPI-bus ($f_{SCL} = 6.5\text{ MHz}$)	-	-	800	μA	
		I ² C-bus ($f_{SCL} = 400\text{ kHz}$)	-	-	200	μA	
		interface inactive ($f_{SCL} = 0\text{ Hz}$)[2]; TCR[1:0] = 00 (see Table 13 on page 12)					
		PWRMNG[2:0] = 111 (see Table 25 on page 18); TSOFF = 1 (see Table 68 on page 50); COF[2:0] = 111 (see Table 15 on page 14)					
		$V_{DD} = 1.8\text{ V}$	-	470	-	nA	
		$V_{DD} = 3.3\text{ V}$	-	700	1500	nA	
		$V_{DD} = 4.2\text{ V}$	-	800	-	nA	
		PWRMNG[2:0] = 111 (see Table 25 on page 18); TSOFF = 1 (see Table 68 on page 50); COF[2:0] = 000 (see Table 15 on page 14)					
		$V_{DD} = 1.8\text{ V}$	-	560	-	nA	
		$V_{DD} = 3.3\text{ V}$	-	850	-	nA	
		$V_{DD} = 4.2\text{ V}$	-	1050	-	nA	
		PWRMNG[2:0] = 000 (see Table 25 on page 18); TSOFF = 0 (see Table 68 on page 50); COF[2:0] = 111 (see Table 15 on page 14)					
		V_{DD} or $V_{BAT} = 1.8\text{ V}$ [3]	-	1750	-	nA	
		V_{DD} or $V_{BAT} = 3.3\text{ V}$ [3]	-	2150	-	nA	
		V_{DD} or $V_{BAT} = 4.2\text{ V}$ [3]	-	2350	3500	nA	
		PWRMNG[2:0] = 000 (see Table 25 on page 18); TSOFF = 0 (see Table 68 on page 50); COF[2:0] = 000 (see Table 15 on page 14)					
		V_{DD} or $V_{BAT} = 1.8\text{ V}$ [3]	-	1840	-	nA	
		V_{DD} or $V_{BAT} = 3.3\text{ V}$ [3]	-	2300	-	nA	
		V_{DD} or $V_{BAT} = 4.2\text{ V}$ [3]	-	2600	-	nA	
$I_{L(bat)}$	battery leakage current	V_{DD} is active supply; $V_{BAT} = 3.0\text{ V}$	-	50	100	nA	

Table 90. Static characteristics ...continued

$V_{DD} = 1.8\text{ V to }4.2\text{ V}$; $V_{SS} = 0\text{ V}$; $T_{amb} = -40\text{ }^{\circ}\text{C to }+85\text{ }^{\circ}\text{C}$, unless otherwise specified.

Symbol	Parameter	Conditions	Min	Typ	Max	Unit	
Power management							
$V_{th(sw)bat}$	battery switch threshold voltage		-	2.5	-	V	
$V_{th(bat)low}$	low battery threshold voltage		-	2.5	-	V	
		$T_{amb} = 25\text{ }^{\circ}\text{C}$	2.25	-	2.85	V	
$V_{th(PFI)}$	threshold voltage on pin PFI		-	1.25	-	V	
Inputs^[4]							
V_I	input voltage		-0.5	-	$V_{DD} + 0.5$	V	
V_{IL}	LOW-level input voltage		-	-	$0.25V_{DD}$	V	
		$T_{amb} = -20\text{ }^{\circ}\text{C to }+85\text{ }^{\circ}\text{C}$; $V_{DD} > 2.0\text{ V}$	-	-	$0.3V_{DD}$	V	
V_{IH}	HIGH-level input voltage		$0.7V_{DD}$	-	-	V	
I_{LI}	input leakage current	$V_I = V_{DD}$ or V_{SS}	-	0	-	μA	
		post ESD event	-1	-	+1	μA	
C_i	input capacitance		[5]	-	7	pF	
Outputs							
V_O	output voltage	on pins CLKOUT, $\overline{\text{INT}}$, $\overline{\text{RST}}$ and PFO, referring to external pull-up	-0.5	-	5.5	V	
		on pin BBS	1.8	-	4.2	V	
		on pin SDO	-0.5	-	$V_{DD} + 0.5$	V	
V_{OH}	HIGH output voltage	on pin SDO	$0.8V_{DD}$	-	V_{DD}	V	
V_{OL}	LOW output voltage	on pins CLKOUT, $\overline{\text{INT}}$, $\overline{\text{RST}}$, SDO, and PFO	V_{SS}	-	$0.2V_{DD}$	V	
I_{OL}	LOW-level output current	output sink current; $V_{OL} = 0.4\text{ V}$					
		on pin SDA/ $\overline{\text{CE}}$	[6]	3	17	-	mA
		on all other outputs		1.0	-	-	mA
I_{OH}	HIGH-level output current	output source current; on pin SDO; $V_{OH} = 3.8\text{ V}$; $V_{DD} = 4.2\text{ V}$	1.0	-	-	mA	
I_{LO}	output leakage current	$V_O = V_{DD}$ or V_{SS}	-	0	-	μA	
		post ESD event	-1	-	+1	μA	

[1] For reliable oscillator start-up at power-on: $V_{DD(po)min} = V_{DD(min)} + 0.3\text{ V}$.

[2] Timer source clock = $\frac{1}{60}\text{ Hz}$, level of pins SDA/ $\overline{\text{CE}}$, SDI, and SCL is V_{DD} or V_{SS} .

[3] When the device is supplied by the V_{BAT} pin instead of the V_{DD} pin, the current values for I_{BAT} are as specified for I_{DD} under the same conditions.

[4] The I²C-bus and SPI-bus interfaces of PCF2127 are 5 V tolerant.

[5] Tested on sample basis.

[6] For further information, see [Figure 49](#).

13.1 Current consumption characteristics, typical

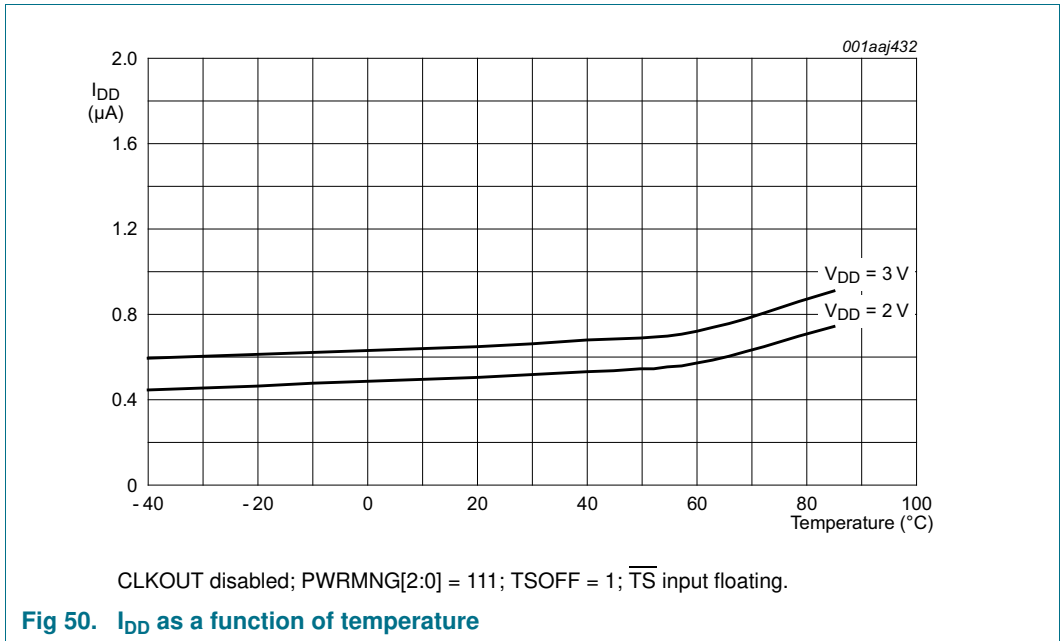
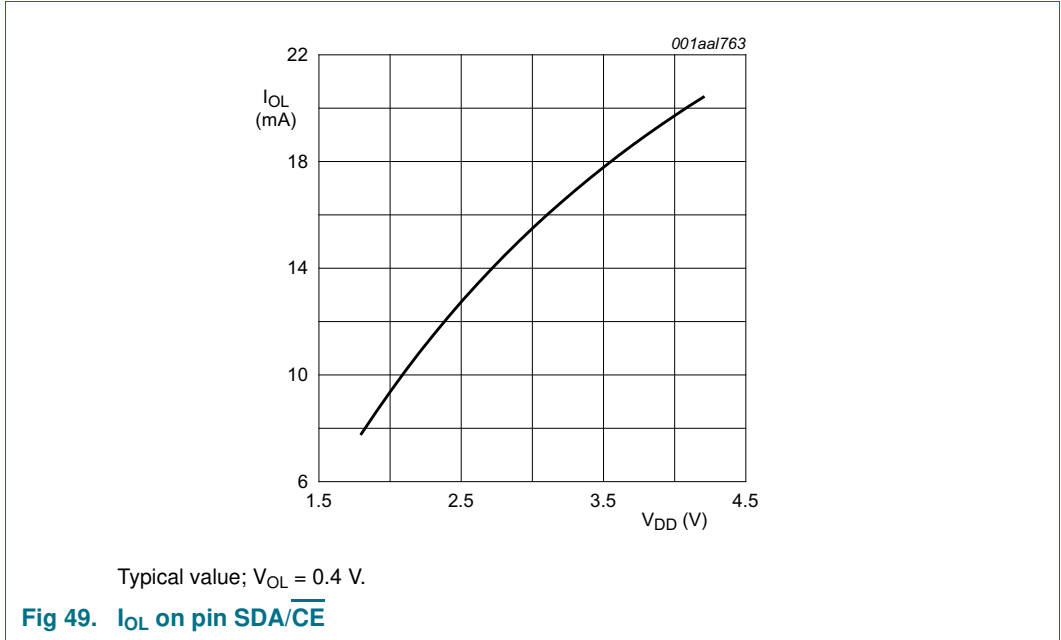

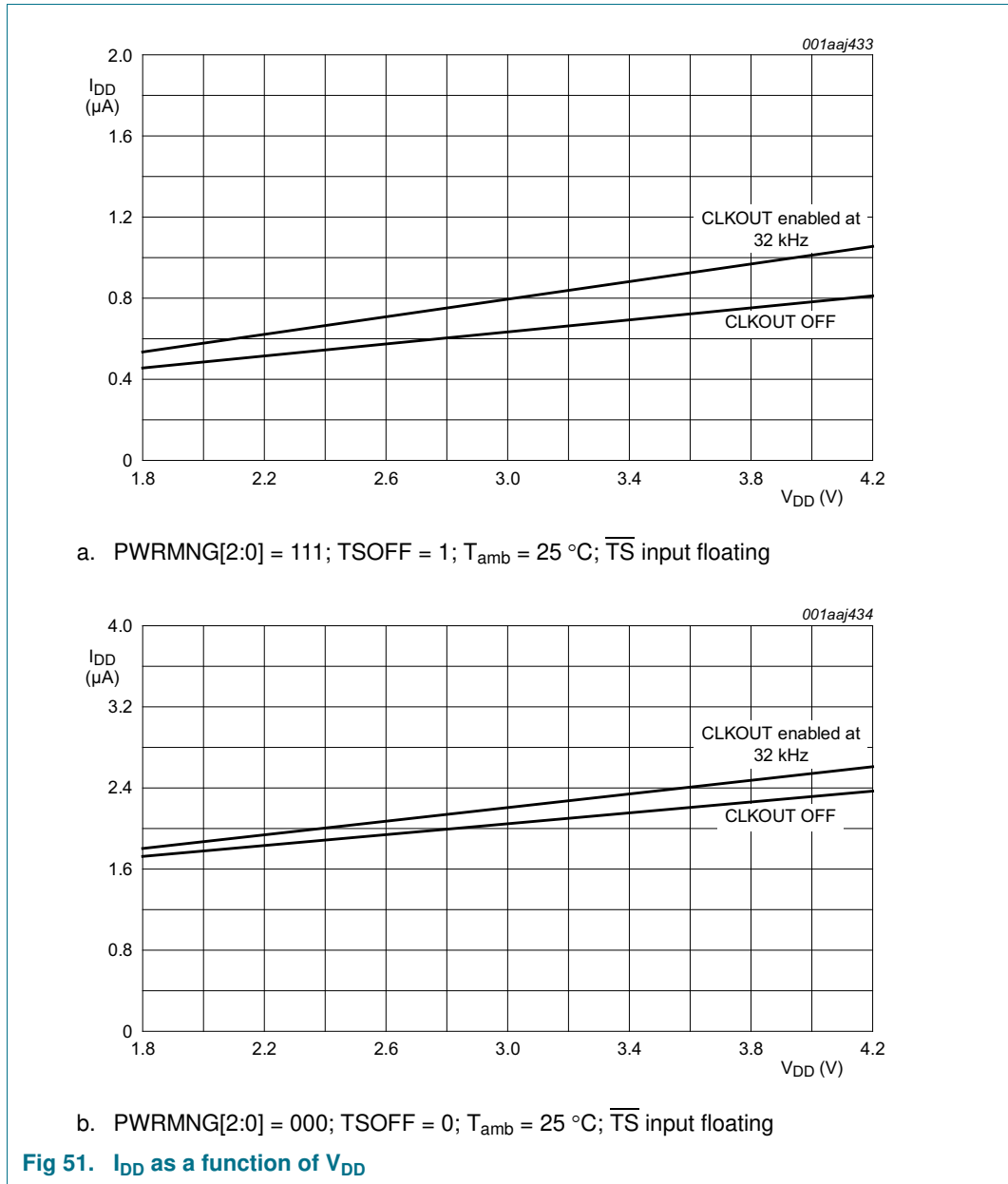

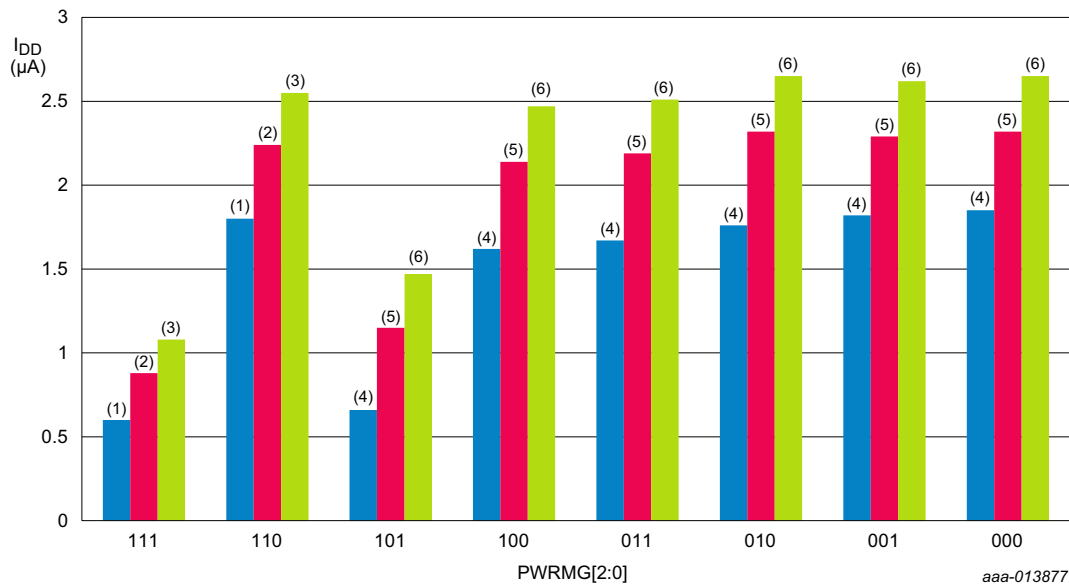

Interface inactive; T_{amb} = 25 °C; V_{BAT} = 0 V; default configuration.

Description of the PWRMNG[2:0] settings, see [Table 25 on page 18](#).

- (1) V_{DD} = 1.8 V.
- (2) V_{DD} = 3.3 V.
- (3) V_{DD} = 4.2 V.
- (4) V_{DD} or V_{BAT} = 1.8 V.
- (5) V_{DD} or V_{BAT} = 3.3 V.
- (6) V_{DD} or V_{BAT} = 4.2 V.

Fig 52. Typical I_{DD} as a function of the power management settings

13.2 Frequency characteristics

Table 91. Frequency characteristics

$V_{DD} = 1.8\text{ V to }4.2\text{ V}$; $V_{SS} = 0\text{ V}$; $T_{amb} = +25\text{ }^{\circ}\text{C}$, unless otherwise specified.

Symbol	Parameter	Conditions	Min	Typ	Max	Unit
f_o	output frequency	on pin CLKOUT; V_{DD} or $V_{BAT} = 3.3\text{ V}$; COF[2:0] = 000; AO[3:0] = 1000	-	32.768	-	kHz
$\Delta f/f$	frequency stability	V_{DD} or $V_{BAT} = 3.3\text{ V}$				
		PCF2127AT				
		$T_{amb} = -15\text{ }^{\circ}\text{C to }+60\text{ }^{\circ}\text{C}$	-	± 3	± 5	ppm
		$T_{amb} = -25\text{ }^{\circ}\text{C to }-15\text{ }^{\circ}\text{C}$ and $T_{amb} = +60\text{ }^{\circ}\text{C to }+65\text{ }^{\circ}\text{C}$	-	± 5	± 10	ppm
		PCF2127T				
		$T_{amb} = -30\text{ }^{\circ}\text{C to }+80\text{ }^{\circ}\text{C}$ [1][2]	-	± 3	± 8	ppm
		$T_{amb} = -40\text{ }^{\circ}\text{C to }-30\text{ }^{\circ}\text{C}$ and $T_{amb} = +80\text{ }^{\circ}\text{C to }+85\text{ }^{\circ}\text{C}$ [1][2]	-	± 5	± 15	ppm
$\Delta f_{\text{xtal}}/f_{\text{xtal}}$	relative crystal frequency variation	crystal aging [3]				
		PCF2127AT				
		first year; V_{DD} or $V_{BAT} = 3.3\text{ V}$	-	-	± 3	ppm
		PCF2127T				
		first year	-	-	± 3	ppm
ten years	-	-	± 8	ppm		
$\Delta f/\Delta V$	frequency variation with voltage	on pin CLKOUT	-	± 1	-	ppm/V

[1] $\pm 1\text{ ppm}$ corresponds to a time deviation of ± 0.0864 seconds per day.

[2] Only valid if CLKOUT frequencies are not equal to 32.768 kHz or if CLKOUT is disabled.

[3] Not production tested. Effects of reflow soldering are included (see [Ref. 3 "AN11266"](#)).

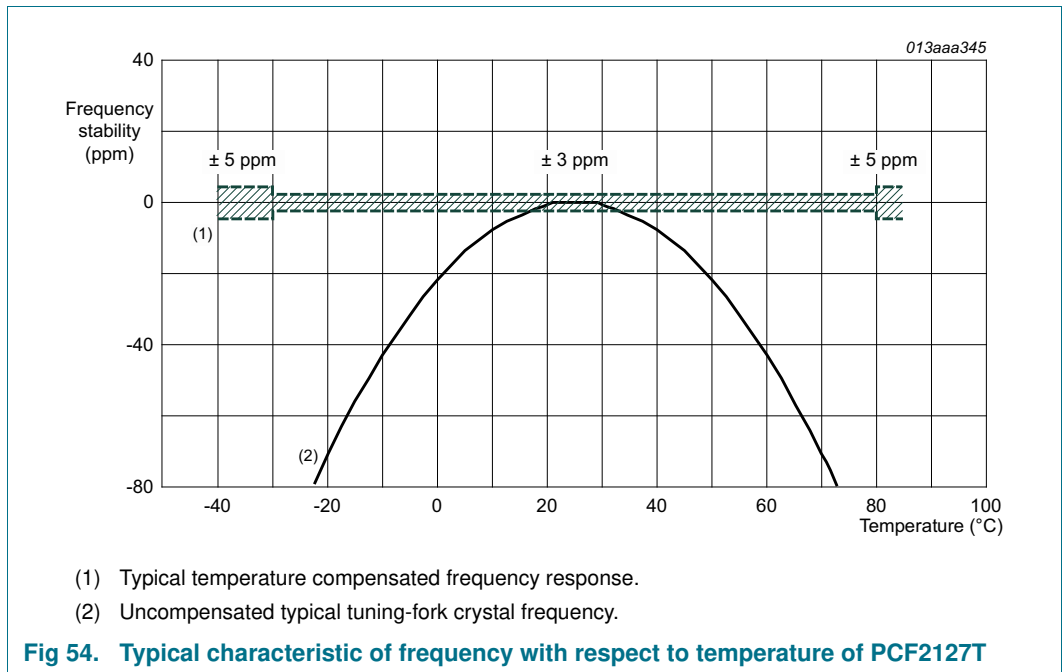
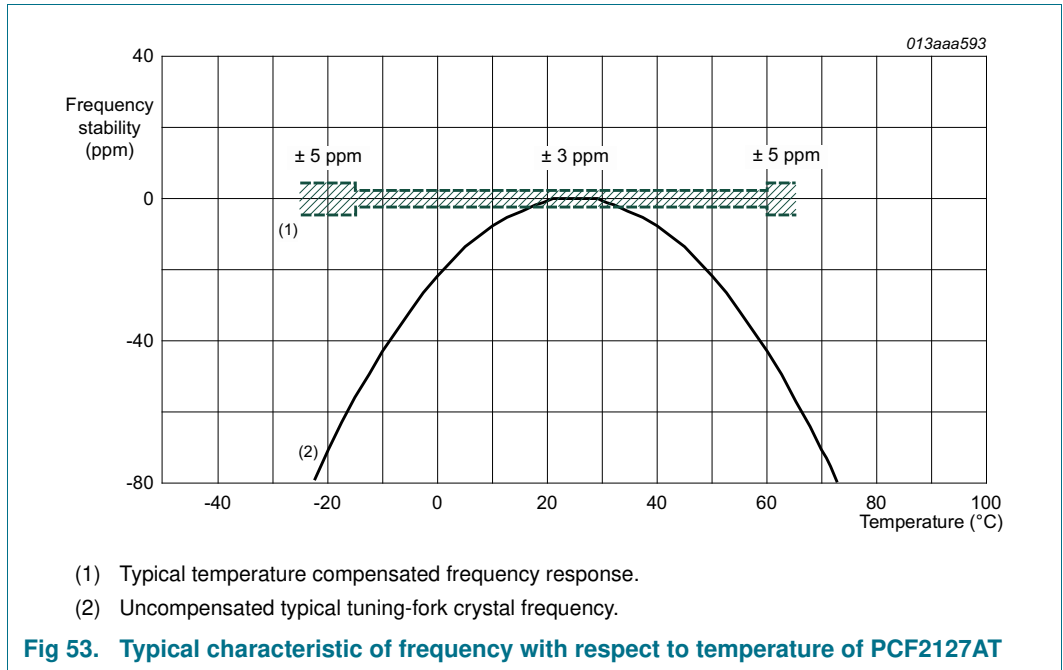

14. Dynamic characteristics

14.1 SPI-bus timing characteristics

Table 92. SPI-bus characteristics

$V_{DD} = 1.8\text{ V to }4.2\text{ V}$; $V_{SS} = 0\text{ V}$; $T_{amb} = -40\text{ }^{\circ}\text{C to }+85\text{ }^{\circ}\text{C}$, unless otherwise specified. All timing values are valid within the operating supply voltage at ambient temperature and referenced to V_{IL} and V_{IH} with an input voltage swing of V_{SS} to V_{DD} (see Figure 55).

Symbol	Parameter	Conditions	$V_{DD} = 1.8\text{ V}$		$V_{DD} = 4.2\text{ V}$		Unit
			Min	Max	Min	Max	
Pin SCL							
$f_{clk(SCL)}$	SCL clock frequency	register read/write access	-	2.0	-	6.5	MHz
		RAM write access	-	2.0	-	6.5	MHz
		RAM read access	-	1.11	-	6.25	MHz
t_{SCL}	SCL time	register read/write access	800	-	140	-	ns
		RAM write access	800	-	140	-	ns
		RAM read access	900	-	160	-	ns
$t_{clk(H)}$	clock HIGH time	register read/write access	100	-	70	-	ns
		RAM write access	100	-	70	-	ns
		RAM read access	450	-	80	-	ns
$t_{clk(L)}$	clock LOW time	register read/write access	400	-	70	-	ns
		RAM write access	400	-	70	-	ns
		RAM read access	450	-	80	-	ns
t_r	rise time	for SCL signal	-	100	-	100	ns
t_f	fall time	for SCL signal	-	100	-	100	ns
Pin SDA/CE							
$t_{su(CE_N)}$	CE_N set-up time		60	-	30	-	ns
$t_{h(CE_N)}$	CE_N hold time		40	-	25	-	ns
$t_{rec(CE_N)}$	CE_N recovery time		100	-	30	-	ns
$t_{w(CE_N)}$	CE_N pulse width		-	0.99	-	0.99	s
Pin SDI							
t_{su}	set-up time	set-up time for SDI data	70	-	20	-	ns
t_h	hold time	hold time for SDI data	70	-	20	-	ns
Pin SDO							
$t_{d(R)SDO}$	SDO read delay time	$C_L = 50\text{ pF}$					
		register read access	-	225	-	55	ns
		RAM read access	-	410	-	55	ns
$t_{dis(SDO)}$	SDO disable time	[1]	-	90	-	25	ns
$t_t(SDI\text{-}SDO)$	transition time from SDI to SDO	to avoid bus conflict	0	-	0	-	ns

[1] No load value; bus is held up by bus capacitance; use RC time constant with application values.

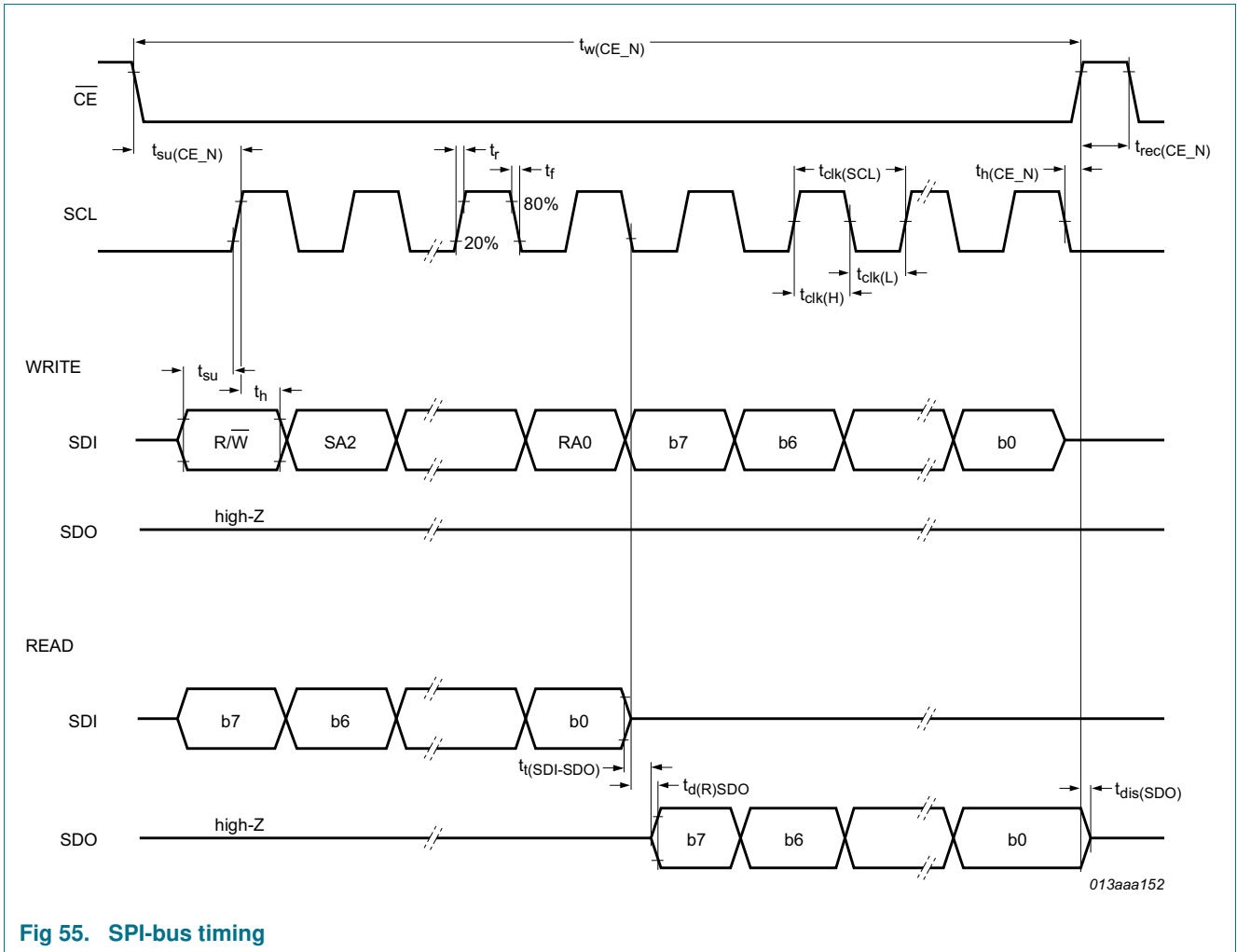

Fig 55. SPI-bus timing

14.2 I²C-bus timing characteristics

Table 93. I²C-bus characteristics

All timing characteristics are valid within the operating supply voltage and ambient temperature range and reference to 30 % and 70 % with an input voltage swing of V_{SS} to V_{DD} (see [Figure 56](#)).

Symbol	Parameter	Standard mode		Fast-mode (Fm)		Unit
		Min	Max	Min	Max	
Pin SCL						
f_{SCL}	SCL clock frequency	0	100	0	400	kHz
t_{LOW}	LOW period of the SCL clock	4.7	-	1.3	-	μ s
t_{HIGH}	HIGH period of the SCL clock	4.0	-	0.6	-	μ s
Pin SDA/CE						
$t_{SU;DAT}$	data set-up time	250	-	100	-	ns
$t_{HD;DAT}$	data hold time	0	-	0	-	ns
Pins SCL and SDA/CE						
t_{BUF}	bus free time between a STOP and START condition	4.7	-	1.3	-	μ s
$t_{SU;STO}$	set-up time for STOP condition	4.0	-	0.6	-	μ s
$t_{HD;STA}$	hold time (repeated) START condition	4.0	-	0.6	-	μ s
$t_{SU;STA}$	set-up time for a repeated START condition	4.7	-	0.6	-	μ s
t_r	rise time of both SDA and SCL signals [1][2][3]	-	1 000	$20 + 0.1C_b$	300	ns
t_f	fall time of both SDA and SCL signals [1][2][3]	-	300	$20 + 0.1C_b$	300	ns
$t_{VD;ACK}$	data valid acknowledge time [4]	0.1	3.45	0.1	0.9	μ s
$t_{VD;DAT}$	data valid time [5]	300	-	75	-	ns
t_{SP}	pulse width of spikes that must be suppressed by the input filter [6]	-	50	-	50	ns

- [1] A master device must internally provide a hold time of at least 300 ns for the SDA signal (refer to the V_{IL} of the SCL signal) in order to bridge the undefined region of the falling edge of SCL.
- [2] C_b is the total capacitance of one bus line in pF.
- [3] The maximum t_f for the SDA and SCL bus lines is 300 ns. The maximum fall time for the SDA output stage, t_f is 250 ns. This allows series protection resistors to be connected between the SDA/CE pin, the SCL pin, and the SDA/SCL bus lines without exceeding the maximum t_f .
- [4] $t_{VD;ACK}$ is the time of the acknowledgement signal from SCL LOW to SDA (out) LOW.
- [5] $t_{VD;DAT}$ is the minimum time for valid SDA (out) data following SCL LOW.
- [6] Input filters on the SDA and SCL inputs suppress noise spikes of less than 50 ns.

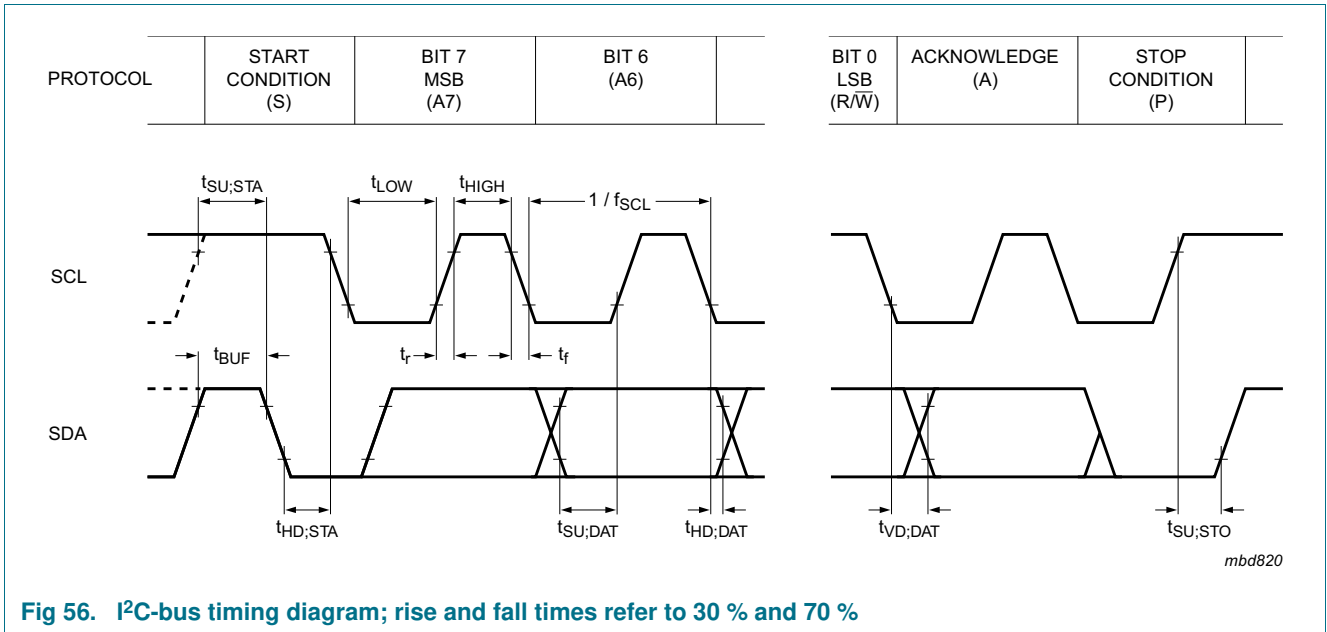
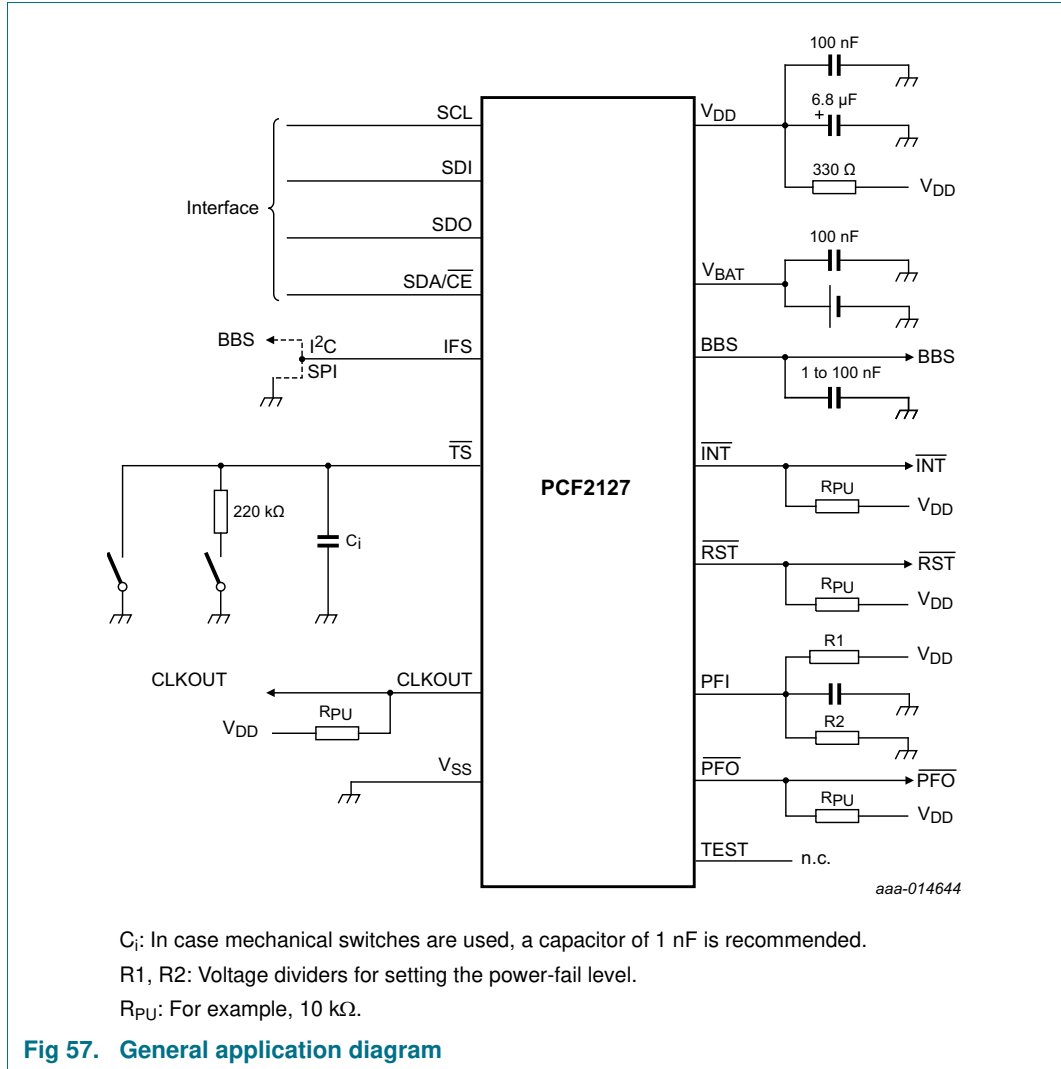

Fig 56. I²C-bus timing diagram; rise and fall times refer to 30 % and 70 %

15. Application information



For information about application configuration, see [Ref. 3 “AN11266” on page 92](#)

16. Test information

16.1 Quality information

UL Component Recognition



This (component or material) is Recognized by UL. Representative samples of this component have been evaluated by UL and meet applicable UL requirements.

17. Package outline

SO20: plastic small outline package; 20 leads; body width 7.5 mm

SOT163-1

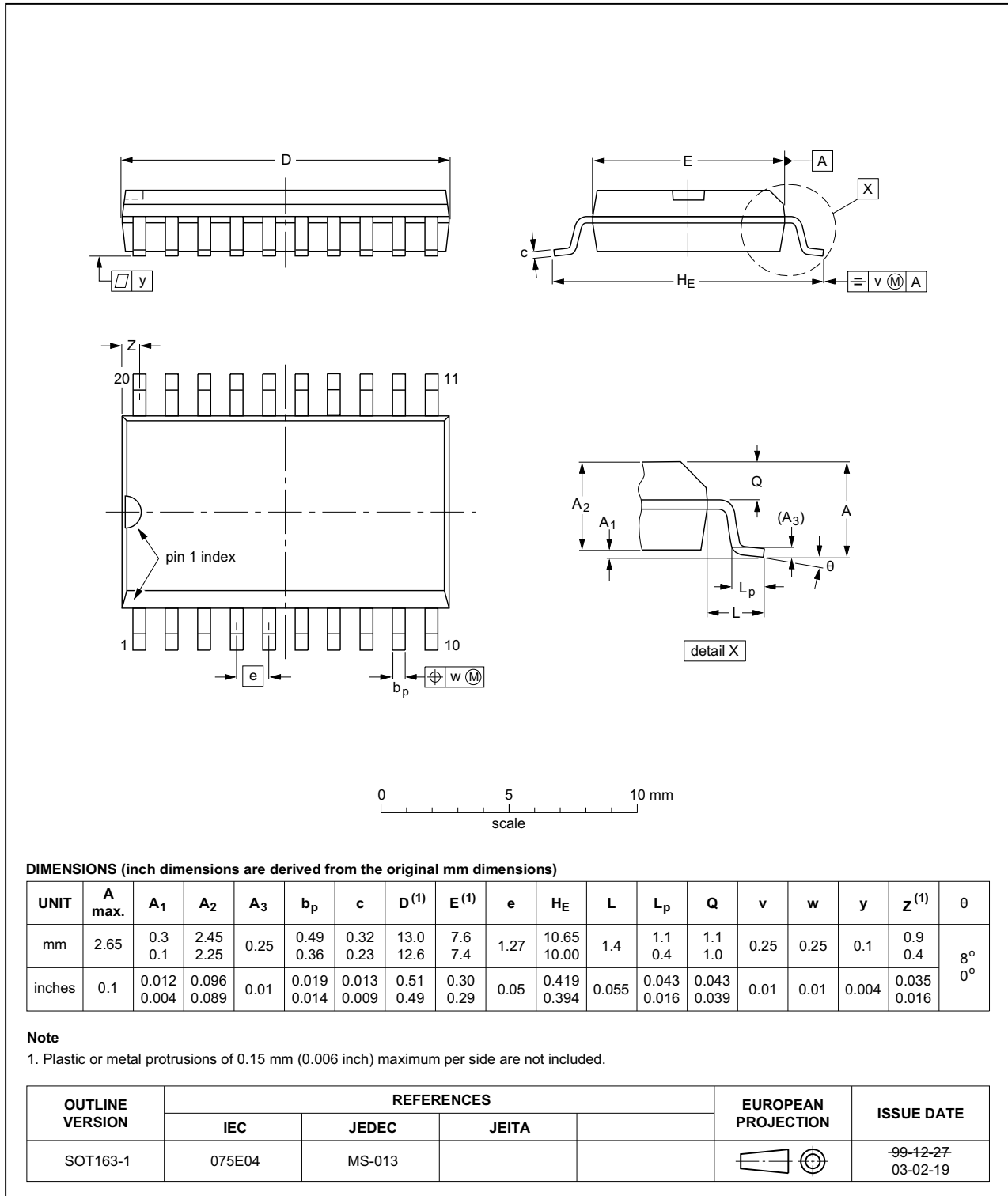

Fig 58. Package outline SOT163-1 (SO20) of PCF2127AT

SO16: plastic small outline package; 16 leads; body width 7.5 mm

SOT162-1

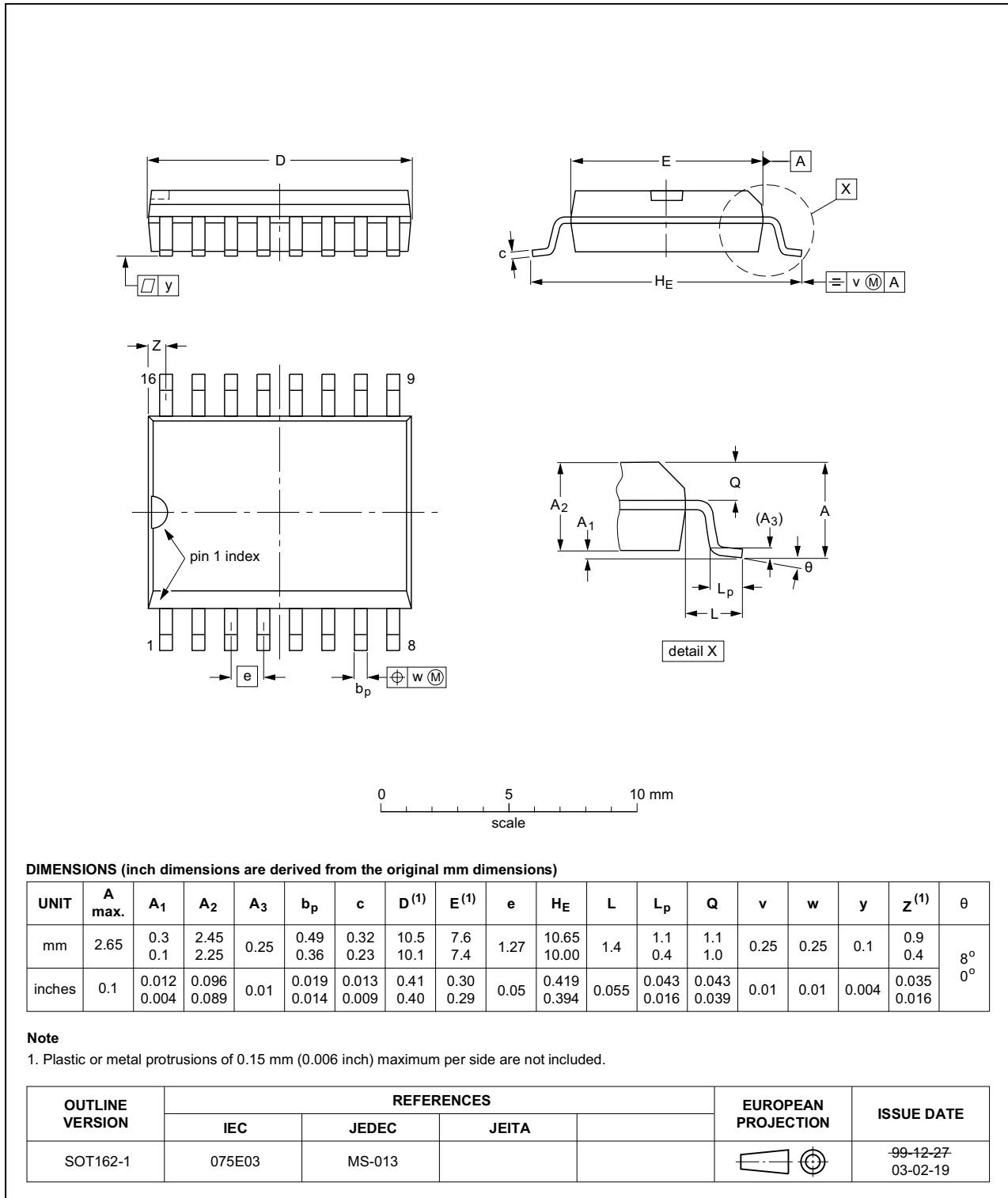

Fig 59. Package outline SOT162-1 (SO16) of PCF2127T

18. Packing information

18.1 Tape and reel information

For tape and reel packing information, see

- [Ref. 11 “SOT162-1 518” on page 92](#) for the PCF2127T.
- [Ref. 12 “SOT163-1 518” on page 92](#) for the PCF2127AT.

19. Soldering

For information about soldering, see [Ref. 3 “AN11266” on page 92](#).

19.1 Footprint information

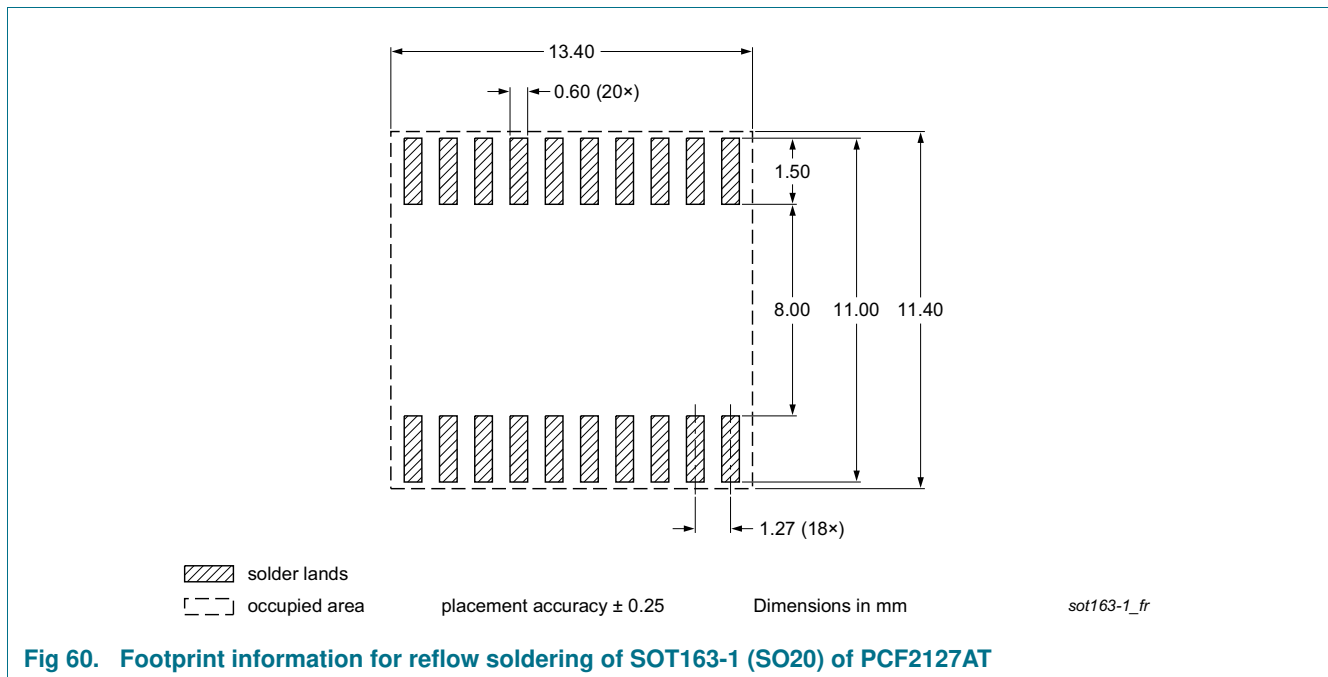

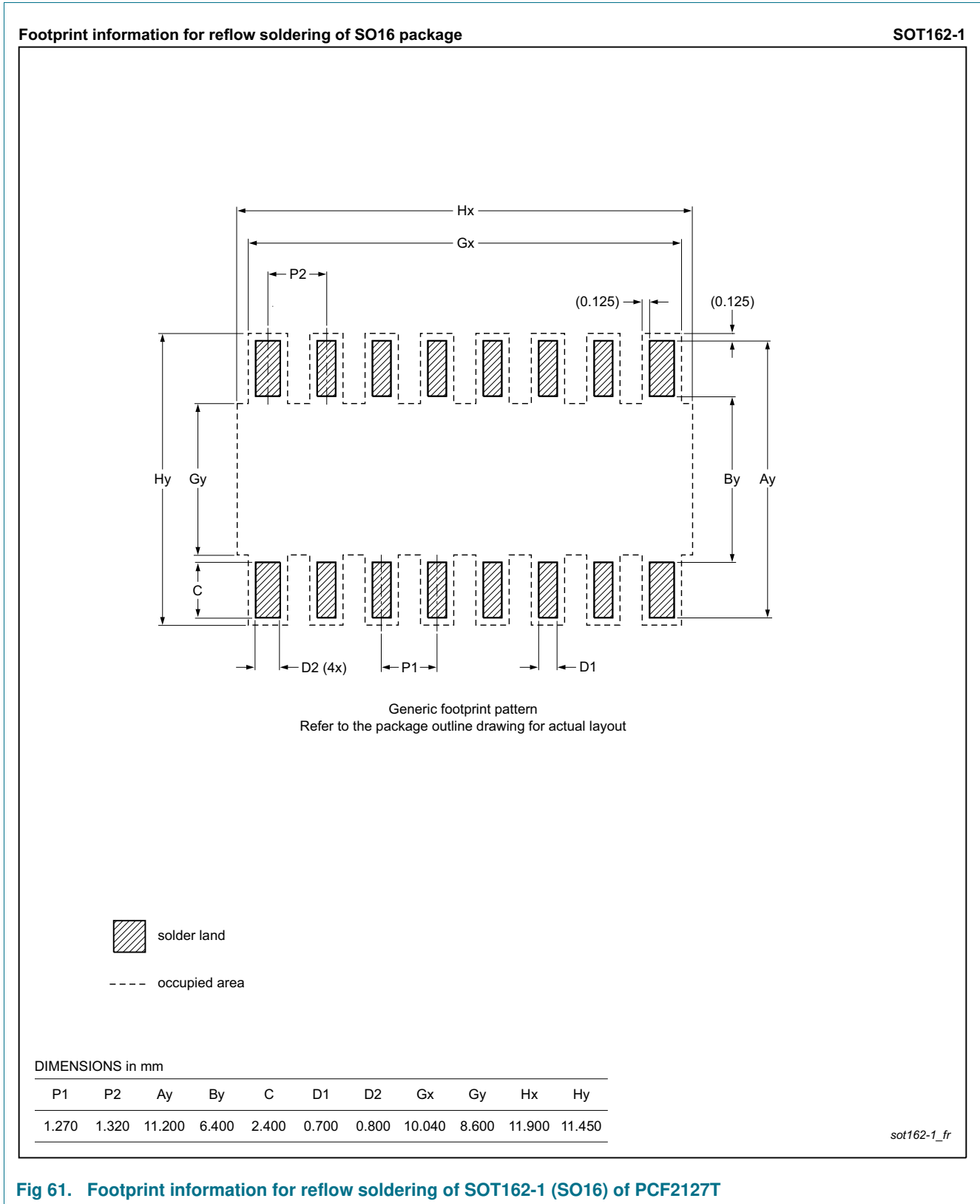

Fig 61. Footprint information for reflow soldering of SOT162-1 (SO16) of PCF2127T

20. Appendix

20.1 Real-Time Clock selection

Table 94. Selection of Real-Time Clocks

Type name	Alarm, Timer, Watchdog	Interrupt output	Interface	I _{DD} , typical (nA)	Battery backup	Timestamp, tamper input	AEC-Q100 compliant	Special features	Packages
PCF8563	X	1	I ² C	250	-	-	-	-	SO8, TSSOP8, HVSON10
PCF8564A	X	1	I ² C	250	-	-	-	integrated oscillator caps	WLCSP
PCA8565	X	1	I ² C	600	-	-	grade 1	high robustness, T _{amb} = -40 °C to 125 °C	TSSOP8, HVSON10
PCA8565A	X	1	I ² C	600	-	-	-	integrated oscillator caps, T _{amb} = -40 °C to 125 °C	WLCSP
PCF85063	-	1	I ² C	220	-	-	-	basic functions only, no alarm	HXSON8
PCF85063A	X	1	I ² C	220	-	-	-	tiny package	SO8, DFN2626-10
PCF85063B	X	1	SPI	220	-	-	-	tiny package	DFN2626-10
PCF85263A	X	2	I ² C	230	X	X	-	time stamp, battery backup, stopwatch 1/100 s	SO8, TSSOP10, TSSOP8, DFN2626-10
PCF85263B	X	2	SPI	230	X	X	-	time stamp, battery backup, stopwatch 1/100s	TSSOP10, DFN2626-10
PCF85363A	X	2	I ² C	230	X	X	-	time stamp, battery backup, stopwatch 1/100s, 64 Byte RAM	TSSOP10, DFN2626-10
PCF85363B	X	2	SPI	230	X	X	-	time stamp, battery backup, stopwatch 1/100s, 64 Byte RAM	TSSOP10, DFN2626-10
PCF8523	X	2	I ² C	150	X	-	-	lowest power 150 nA in operation, FM+ 1 MHz	SO8, HVSON8, TSSOP14, WLCSP
PCF2123	X	1	SPI	100	-	-	-	lowest power 100 nA in operation	TSSOP14, HVQFN16
PCF2127	X	1	I ² C and SPI	500	X	X	-	temperature compensated, quartz built in, calibrated, 512 Byte RAM	SO16

Table 94. Selection of Real-Time Clocks ...continued

Type name	Alarm, Timer, Watchdog	Interrupt output	Interface	I _{DD} , typical (nA)	Battery backup	Timestamp, tamper input	AEC-Q100 compliant	Special features	Packages
PCF2127A	X	1	I ² C and SPI	500	X	X	-	temperature compensated, quartz built in, calibrated, 512 Byte RAM	SO20
PCF2129	X	1	I ² C and SPI	500	X	X	-	temperature compensated, quartz built in, calibrated	SO16
PCF2129A	X	1	I ² C and SPI	500	X	X	-	temperature compensated, quartz built in, calibrated	SO20
PCA2129	X	1	I ² C and SPI	500	X	X	grade 3	temperature compensated, quartz built in, calibrated	SO16
PCA21125	X	1	SPI	820	-	-	grade 1	high robustness, T _{amb} = -40 °C to 125 °C	TSSOP14

21. Abbreviations

Table 95. Abbreviations

Acronym	Description
ACK	ACKnowledge (I ² C-bus)
AM	Ante Meridiem
BCD	Binary Coded Decimal
CDM	Charged Device Model
CMOS	Complementary Metal-Oxide Semiconductor
DC	Direct Current
GPS	Global Positioning System
HBM	Human Body Model
I ² C	Inter-Integrated Circuit
IC	Integrated Circuit
LSB	Least Significant Bit
MCU	Microcontroller Unit
MSB	Most Significant Bit
PM	Post Meridiem
POR	Power-On Reset
PORO	Power-On Reset Override
PPM	Parts Per Million
RAM	Random Access Memory
RC	Resistance-Capacitance
RTC	Real Time Clock
SCL	Serial CLock line
SDA	Serial DAta line
SPI	Serial Peripheral Interface
SRAM	Static Random Access Memory
TCXO	Temperature Compensated Xtal Oscillator
Xtal	crystal

22. References

- [1] **AN10365** — Surface mount reflow soldering description
- [2] **AN10853** — Handling precautions of ESD sensitive devices
- [3] **AN11266** — Application and soldering information for the PCF2127 industrial TCXO RTC
- [4] **IEC 60134** — Rating systems for electronic tubes and valves and analogous semiconductor devices
- [5] **IEC 61340-5** — Protection of electronic devices from electrostatic phenomena
- [6] **IPC/JEDEC J-STD-020D** — Moisture/Reflow Sensitivity Classification for Nonhermetic Solid State Surface Mount Devices
- [7] **JESD22-A114** — Electrostatic Discharge (ESD) Sensitivity Testing Human Body Model (HBM)
- [8] **JESD22-C101** — Field-Induced Charged-Device Model Test Method for Electrostatic-Discharge-Withstand Thresholds of Microelectronic Components
- [9] **JESD78** — IC Latch-Up Test
- [10] **JESD625-A** — Requirements for Handling Electrostatic-Discharge-Sensitive (ESDS) Devices
- [11] **SOT162-1_518** — SO16; Reel pack; SMD, 13", packing information
- [12] **SOT163-1_518** — SO20; Reel pack; SMD, 13", packing information
- [13] **UM10204** — I²C-bus specification and user manual
- [14] **UM10569** — Store and transport requirements
- [15] **UM10762** — User manual for the accurate RTC demo board OM13513 containing PCF2127T and PCF2129AT

23. Revision history

Table 96. Revision history

Document ID	Release date	Data sheet status	Change notice	Supersedes
PCF2127 v.8	20141219	Product data sheet	-	PCF2127 v.7
Modifications:	<ul style="list-style-type: none"> • Added V_{OH} and V_{OL} values in Table 90 • Enhanced ESD HBM values • Corrected Figure 8 • Enhanced description of internal operating voltage • Added register bit allocation tables • Fixed typos 			
PCF2127 v.7	20141003	Product data sheet	-	PCF2127AT v.6 PCF2127 v.3
PCF2127AT				
PCF2127AT v.6	20130711	Product data sheet	-	PCF2127AT v.5
PCF2127AT v.5	20130128	Product data sheet	-	PCF2127AT v.4
PCF2127AT v.4	20121207	Product data sheet	-	PCF2127AT v.3
PCF2127AT v.3	20121004	Product data sheet	-	PCF2127A v.2
PCF2127A v.2	20100507	Product data sheet	-	PCF2127A v.1
PCF2127A v.1	20100121	Product data sheet	-	-
PCF2127T				
PCF2127 v.3	20130711	Product data sheet	-	PCF2127 v.2
PCF2127 v.2	20130422	Product data sheet	-	PCF2127 v.1
PCF2127 v.1	20130212	Product data sheet	-	-

24. Legal information

24.1 Data sheet status

Document status ^{[1][2]}	Product status ^[3]	Definition
Objective [short] data sheet	Development	This document contains data from the objective specification for product development.
Preliminary [short] data sheet	Qualification	This document contains data from the preliminary specification.
Product [short] data sheet	Production	This document contains the product specification.

[1] Please consult the most recently issued document before initiating or completing a design.

[2] The term 'short data sheet' is explained in section "Definitions".

[3] The product status of device(s) described in this document may have changed since this document was published and may differ in case of multiple devices. The latest product status information is available on the Internet at URL <http://www.nxp.com>.

24.2 Definitions

Draft — The document is a draft version only. The content is still under internal review and subject to formal approval, which may result in modifications or additions. NXP Semiconductors does not give any representations or warranties as to the accuracy or completeness of information included herein and shall have no liability for the consequences of use of such information.

Short data sheet — A short data sheet is an extract from a full data sheet with the same product type number(s) and title. A short data sheet is intended for quick reference only and should not be relied upon to contain detailed and full information. For detailed and full information see the relevant full data sheet, which is available on request via the local NXP Semiconductors sales office. In case of any inconsistency or conflict with the short data sheet, the full data sheet shall prevail.

Product specification — The information and data provided in a Product data sheet shall define the specification of the product as agreed between NXP Semiconductors and its customer, unless NXP Semiconductors and customer have explicitly agreed otherwise in writing. In no event however, shall an agreement be valid in which the NXP Semiconductors product is deemed to offer functions and qualities beyond those described in the Product data sheet.

24.3 Disclaimers

Limited warranty and liability — Information in this document is believed to be accurate and reliable. However, NXP Semiconductors does not give any representations or warranties, expressed or implied, as to the accuracy or completeness of such information and shall have no liability for the consequences of use of such information. NXP Semiconductors takes no responsibility for the content in this document if provided by an information source outside of NXP Semiconductors.

In no event shall NXP Semiconductors be liable for any indirect, incidental, punitive, special or consequential damages (including - without limitation - lost profits, lost savings, business interruption, costs related to the removal or replacement of any products or rework charges) whether or not such damages are based on tort (including negligence), warranty, breach of contract or any other legal theory.

Notwithstanding any damages that customer might incur for any reason whatsoever, NXP Semiconductors' aggregate and cumulative liability towards customer for the products described herein shall be limited in accordance with the *Terms and conditions of commercial sale* of NXP Semiconductors.

Right to make changes — NXP Semiconductors reserves the right to make changes to information published in this document, including without limitation specifications and product descriptions, at any time and without notice. This document supersedes and replaces all information supplied prior to the publication hereof.

Suitability for use — NXP Semiconductors products are not designed, authorized or warranted to be suitable for use in life support, life-critical or safety-critical systems or equipment, nor in applications where failure or malfunction of an NXP Semiconductors product can reasonably be expected to result in personal injury, death or severe property or environmental damage. NXP Semiconductors and its suppliers accept no liability for inclusion and/or use of NXP Semiconductors products in such equipment or applications and therefore such inclusion and/or use is at the customer's own risk.

Applications — Applications that are described herein for any of these products are for illustrative purposes only. NXP Semiconductors makes no representation or warranty that such applications will be suitable for the specified use without further testing or modification.

Customers are responsible for the design and operation of their applications and products using NXP Semiconductors products, and NXP Semiconductors accepts no liability for any assistance with applications or customer product design. It is customer's sole responsibility to determine whether the NXP Semiconductors product is suitable and fit for the customer's applications and products planned, as well as for the planned application and use of customer's third party customer(s). Customers should provide appropriate design and operating safeguards to minimize the risks associated with their applications and products.

NXP Semiconductors does not accept any liability related to any default, damage, costs or problem which is based on any weakness or default in the customer's applications or products, or the application or use by customer's third party customer(s). Customer is responsible for doing all necessary testing for the customer's applications and products using NXP Semiconductors products in order to avoid a default of the applications and the products or of the application or use by customer's third party customer(s). NXP does not accept any liability in this respect.

Limiting values — Stress above one or more limiting values (as defined in the Absolute Maximum Ratings System of IEC 60134) will cause permanent damage to the device. Limiting values are stress ratings only and (proper) operation of the device at these or any other conditions above those given in the Recommended operating conditions section (if present) or the Characteristics sections of this document is not warranted. Constant or repeated exposure to limiting values will permanently and irreversibly affect the quality and reliability of the device.

Terms and conditions of commercial sale — NXP Semiconductors products are sold subject to the general terms and conditions of commercial sale, as published at <http://www.nxp.com/profile/terms>, unless otherwise agreed in a valid written individual agreement. In case an individual agreement is concluded only the terms and conditions of the respective agreement shall apply. NXP Semiconductors hereby expressly objects to applying the customer's general terms and conditions with regard to the purchase of NXP Semiconductors products by customer.

No offer to sell or license — Nothing in this document may be interpreted or construed as an offer to sell products that is open for acceptance or the grant, conveyance or implication of any license under any copyrights, patents or other industrial or intellectual property rights.

Export control — This document as well as the item(s) described herein may be subject to export control regulations. Export might require a prior authorization from competent authorities.

Non-automotive qualified products — Unless this data sheet expressly states that this specific NXP Semiconductors product is automotive qualified, the product is not suitable for automotive use. It is neither qualified nor tested in accordance with automotive testing or application requirements. NXP Semiconductors accepts no liability for inclusion and/or use of non-automotive qualified products in automotive equipment or applications.

In the event that customer uses the product for design-in and use in automotive applications to automotive specifications and standards, customer (a) shall use the product without NXP Semiconductors' warranty of the product for such automotive applications, use and specifications, and (b) whenever customer uses the product for automotive applications beyond NXP Semiconductors' specifications such use shall be solely at customer's

own risk, and (c) customer fully indemnifies NXP Semiconductors for any liability, damages or failed product claims resulting from customer design and use of the product for automotive applications beyond NXP Semiconductors' standard warranty and NXP Semiconductors' product specifications.

Translations — A non-English (translated) version of a document is for reference only. The English version shall prevail in case of any discrepancy between the translated and English versions.

24.4 Trademarks

Notice: All referenced brands, product names, service names and trademarks are the property of their respective owners.

I²C-bus — logo is a trademark of NXP Semiconductors N.V.

25. Contact information

For more information, please visit: <http://www.nxp.com>

For sales office addresses, please send an email to: salesaddresses@nxp.com

26. Tables

Table 1.	Ordering information	2			
Table 2.	Ordering options	2			
Table 3.	Marking codes	2			
Table 4.	Pin description of PCF2127	5			
Table 5.	Register overview	8			
Table 6.	Control_1 - control and status register 1 (address 00h) bit allocation	10			
Table 7.	Control_1 - control and status register 1 (address 00h) bit description	10			
Table 8.	Control_2 - control and status register 2 (address 01h) bit allocation	11			
Table 9.	Control_2 - control and status register 2 (address 01h) bit description	11			
Table 10.	Control_3 - control and status register 3 (address 02h) bit allocation	12			
Table 11.	Control_3 - control and status register 3 (address 02h) bit description	12			
Table 12.	CLKOUT_ctl - CLKOUT control register (address 0Fh) bit allocation	12			
Table 13.	CLKOUT_ctl - CLKOUT control register (address 0Fh) bit description	12			
Table 14.	Temperature measurement period	13			
Table 15.	CLKOUT frequency selection	14			
Table 16.	Aging_offset - crystal aging offset register (address 19h) bit allocation	14			
Table 17.	Aging_offset - crystal aging offset register (address 19h) bit description	14			
Table 18.	Frequency correction at 25 °C, typical	15			
Table 19.	RAM_addr_MSB - RAM address MSB register (address 1Ah) bit allocation	16			
Table 20.	RAM_addr_MSB - RAM address MSB register (address 1Ah) bit description	16			
Table 21.	RAM_addr_LSB - RAM address LSB register (address 1Bh) bit allocation	16			
Table 22.	RAM_addr_LSB - RAM address LSB register (address 1Bh) bit description	16			
Table 23.	RAM_wrt_cmd - RAM write command register (address 1Ch) bit description	16			
Table 24.	RAM_rd_cmd - RAM read command register (address 1Dh) bit description	16			
Table 25.	Power management control bit description	18			
Table 26.	Output pin BBS	26			
Table 27.	Seconds - seconds and clock integrity register (address 03h) bit allocation	30			
Table 28.	Seconds - seconds and clock integrity register (address 03h) bit description	30			
Table 29.	Seconds coded in BCD format	31			
Table 30.	Minutes - minutes register (address 04h) bit allocation	31			
Table 31.	Minutes - minutes register (address 04h) bit description	31			
Table 32.	Hours - hours register (address 05h) bit allocation	32			
Table 33.	Hours - hours register (address 05h) bit description	32			
Table 34.	Days - days register (address 06h) bit allocation	32			
Table 35.	Days - days register (address 06h) bit description	32			
Table 36.	Weekdays - weekdays register (address 07h) bit allocation	33			
Table 37.	Weekdays - weekdays register (address 07h) bit description	33			
Table 38.	Weekday assignments	33			
Table 39.	Months - months register (address 08h) bit allocation	34			
Table 40.	Months - months register (address 08h) bit description	34			
Table 41.	Month assignments in BCD format	34			
Table 42.	Years - years register (address 09h) bit allocation	35			
Table 43.	Years - years register (address 09h) bit description	35			
Table 44.	Second_alarm - second alarm register (address 0Ah) bit allocation	38			
Table 45.	Second_alarm - second alarm register (address 0Ah) bit description	38			
Table 46.	Minute_alarm - minute alarm register (address 0Bh) bit allocation	38			
Table 47.	Minute_alarm - minute alarm register (address 0Bh) bit description	38			
Table 48.	Hour_alarm - hour alarm register (address 0Ch) bit allocation	39			
Table 49.	Hour_alarm - hour alarm register (address 0Ch) bit description	39			
Table 50.	Day_alarm - day alarm register (address 0Dh) bit allocation	39			
Table 51.	Day_alarm - day alarm register (address 0Dh) bit description	39			
Table 52.	Weekday_alarm - weekday alarm register (address 0Eh) bit allocation	40			
Table 53.	Weekday_alarm - weekday alarm register (address 0Eh) bit description	40			
Table 54.	Watchdg_tim_ctl - watchdog timer control register (address 10h) bit allocation	41			
Table 55.	Watchdg_tim_ctl - watchdog timer control register (address 10h) bit description	41			
Table 56.	Watchdg_tim_val - watchdog timer value register (address 11h) bit allocation	42			
Table 57.	Watchdg_tim_val - watchdog timer value register (address 11h) bit description	42			
Table 58.	Programmable watchdog timer	42			
Table 59.	Specification of $t_{w(rst)}$	44			
Table 60.	First period delay for timer counter	45			
Table 61.	Flag location in register Control_2	46			
Table 62.	Example values in register Control_2	46			
Table 63.	Example to clear only CDTF (bit 3)	46			
Table 64.	Example to clear only AF (bit 4)	46			
Table 65.	Example to clear only MSF (bit 7)	47			
Table 66.	Example to clear both CDTF and MSF	47			
Table 67.	Timestp_ctl - timestamp control register (address 12h) bit allocation	50			

Table 68. Timestp_ctl - timestamp control register (address 12h) bit description50

Table 69. Sec_timestp - second timestamp register (address 13h) bit allocation50

Table 70. Sec_timestp - second timestamp register (address 13h) bit description50

Table 71. Min_timestp - minute timestamp register (address 14h) bit allocation51

Table 72. Min_timestp - minute timestamp register (address 14h) bit description51

Table 73. Hour_timestp - hour timestamp register (address 15h) bit allocation51

Table 74. Hour_timestp - hour timestamp register (address 15h) bit description51

Table 75. Day_timestp - day timestamp register (address 16h) bit allocation52

Table 76. Day_timestp - day timestamp register (address 16h) bit description52

Table 77. Mon_timestp - month timestamp register (address 17h) bit allocation52

Table 78. Mon_timestp - month timestamp register (address 17h) bit description52

Table 79. Year_timestp - year timestamp register (address 18h) bit allocation52

Table 80. Year_timestp - year timestamp register (address 18h) bit description52

Table 81. Battery switch-over and timestamp.53

Table 82. Effect of bits MI and SI on pin INT and bit MSF55

Table 83. INT operation (bit TI_TP = 1)57

Table 84. First increment of time circuits after stop release60

Table 85. Interface selection input pin IFS62

Table 86. Serial interface63

Table 87. Command byte definition63

Table 88. I²C slave address byte68

Table 89. Limiting values72

Table 90. Static characteristics73

Table 91. Frequency characteristics78

Table 92. SPI-bus characteristics.80

Table 93. I²C-bus characteristics82

Table 94. Selection of Real-Time Clocks89

Table 95. Abbreviations91

Table 96. Revision history93

27. Figures

Fig 1. Block diagram of PCF2127	3	Fig 38. SPI-bus write examples	64
Fig 2. Pin configuration for PCF2127AT (SO20)	4	Fig 39. SPI-bus read examples	65
Fig 3. Pin configuration for PCF2127T (SO16)	4	Fig 40. Bit transfer	66
Fig 4. Position of the stubs from the package assembly process	4	Fig 41. Definition of START and STOP conditions	66
Fig 5. Handling address registers	6	Fig 42. System configuration	67
Fig 6. Battery switch-over behavior in standard mode with bit BIE set logic 1 (enabled)	20	Fig 43. Acknowledgement on the I ² C-bus	67
Fig 7. Battery switch-over behavior in direct switching mode with bit BIE set logic 1 (enabled)	21	Fig 44. Bus protocol, writing to registers	68
Fig 8. Battery switch-over circuit, simplified block diagram	22	Fig 45. Bus protocol, reading from registers	68
Fig 9. Battery low detection behavior with bit BLIE set logic 1 (enabled)	23	Fig 46. Bus protocol, writing to RAM	69
Fig 10. Typical application of the extra power fail detection function	23	Fig 47. Bus protocol, reading from RAM	70
Fig 11. PFO signal behavior when battery switch-over is enabled in standard mode and $V_{th(uvp)} > (V_{BAT}, V_{th(sw)bat})$	25	Fig 48. Device diode protection diagram of PCF2127	71
Fig 12. PFO signal behavior when battery switch-over is enabled in direct switching mode and $V_{th(uvp)} < V_{BAT}$	25	Fig 49. I _{OL} on pin SDA/ \overline{CE}	75
Fig 13. PFO signal behavior when battery switch-over is disabled	26	Fig 50. I _{DD} as a function of temperature	75
Fig 14. Typical driving capability of V _{BBS} : (V _{BBS} - V _{DD}) with respect to the output load current I _{BBS}	27	Fig 51. I _{DD} as a function of V _{DD}	76
Fig 15. Power failure event due to battery discharge: reset occurs	28	Fig 52. Typical I _{DD} as a function of the power management settings	77
Fig 16. Dependency between POR and oscillator	29	Fig 53. Typical characteristic of frequency with respect to temperature of PCF2127AT	79
Fig 17. Power-On Reset (POR) system	29	Fig 54. Typical characteristic of frequency with respect to temperature of PCF2127T	79
Fig 18. Power-On Reset Override (PORO) sequence, valid for both I ² C-bus and SPI-bus	30	Fig 55. SPI-bus timing	81
Fig 19. Data flow of the time function	35	Fig 56. I ² C-bus timing diagram; rise and fall times refer to 30 % and 70 %	83
Fig 20. Access time for read/write operations	36	Fig 57. General application diagram	84
Fig 21. Alarm function block diagram	37	Fig 58. Package outline SOT163-1 (SO20) of PCF2127AT	85
Fig 22. Alarm flag timing diagram	40	Fig 59. Package outline SOT162-1 (SO16) of PCF2127T	86
Fig 23. WD_CD[1:0] = 10: watchdog activates an interrupt when timed out	43	Fig 60. Footprint information for reflow soldering of SOT163-1 (SO20) of PCF2127AT	87
Fig 24. WD_CD[1:0] = 11: watchdog activates a reset pulse when timed out	44	Fig 61. Footprint information for reflow soldering of SOT162-1 (SO16) of PCF2127T	88
Fig 25. General countdown timer behavior	45		
Fig 26. Timestamp detection with two push-buttons on the \overline{TS} pin (for example, for tamper detection)	48		
Fig 27. Interrupt block diagram	54		
Fig 28. \overline{INT} example for SI and MI when TI_TP is logic 156	56		
Fig 29. \overline{INT} example for SI and MI when TI_TP is logic 056	56		
Fig 30. Example of shortening the \overline{INT} pulse by clearing the MSF flag	57		
Fig 31. Example of shortening the \overline{INT} pulse by clearing the CDTF flag	57		
Fig 32. AF timing diagram	58		
Fig 33. STOP bit functional diagram	60		
Fig 34. STOP bit release timing	61		
Fig 35. Interface selection	62		
Fig 36. SDI, SDO configurations	62		
Fig 37. Data transfer overview	63		

28. Contents

1	General description	1	8.8	Reset function	28
2	Features and benefits	1	8.8.1	Power-On Reset (POR)	28
3	Applications	2	8.8.2	Power-On Reset Override (PORO)	29
4	Ordering information	2	8.9	Time and date function	30
4.1	Ordering options	2	8.9.1	Register Seconds	30
5	Marking	2	8.9.2	Register Minutes	31
6	Block diagram	3	8.9.3	Register Hours	32
7	Pinning information	4	8.9.4	Register Days	32
7.1	Pinning	4	8.9.5	Register Weekdays	33
7.2	Pin description	5	8.9.6	Register Months	34
8	Functional description	6	8.9.7	Register Years	35
8.1	Register overview	6	8.9.8	Setting and reading the time	35
8.2	Control registers	10	8.10	Alarm function	37
8.2.1	Register Control_1	10	8.10.1	Register Second_alarm	38
8.2.2	Register Control_2	11	8.10.2	Register Minute_alarm	38
8.2.3	Register Control_3	12	8.10.3	Register Hour_alarm	39
8.3	Register CLKOUT_ctl	12	8.10.4	Register Day_alarm	39
8.3.1	Temperature compensated crystal oscillator	13	8.10.5	Register Weekday_alarm	40
8.3.1.1	Temperature measurement	13	8.10.6	Alarm flag	40
8.3.2	OTP refresh	13	8.11	Timer functions	40
8.3.3	Clock output	13	8.11.1	Register Watchdog_tim_ctl	41
8.4	Register Aging_offset	14	8.11.2	Register Watchdog_tim_val	42
8.4.1	Crystal aging correction	14	8.11.3	Watchdog timer function	42
8.5	General purpose 512 bytes static RAM	15	8.11.4	Countdown timer function	44
8.5.1	Register RAM_addr_MSB	16	8.11.5	Pre-defined timers: second and minute interrupt	46
8.5.2	Register RAM_addr_LSB	16	8.11.6	Clearing flags	46
8.5.3	Register RAM_wrt_cmd	16	8.12	Timestamp function	48
8.5.4	Register RAM_rd_cmd	16	8.12.1	Timestamp flag	48
8.5.5	Operation examples	17	8.12.2	Timestamp mode	49
8.5.5.1	Writing to the RAM	17	8.12.3	Timestamp registers	50
8.5.5.2	Reading from the RAM	17	8.12.3.1	Register Timestp_ctl	50
8.6	Power management functions	17	8.12.3.2	Register Sec_timestp	50
8.6.1	Battery switch-over function	19	8.12.3.3	Register Min_timestp	51
8.6.1.1	Standard mode	20	8.12.3.4	Register Hour_timestp	51
8.6.1.2	Direct switching mode	21	8.12.3.5	Register Day_timestp	52
8.6.1.3	Battery switch-over disabled: only one power supply (V _{DD})	21	8.12.3.6	Register Mon_timestp	52
8.6.1.4	Battery switch-over architecture	22	8.12.3.7	Register Year_timestp	52
8.6.2	Battery low detection function	22	8.12.4	Dependency between Battery switch-over and timestamp	53
8.6.3	Extra power fail detection function	23	8.13	Interrupt output, INT	54
8.6.3.1	Extra power fail detection when the battery switch-over function is enabled	24	8.13.1	Minute and second interrupts	55
8.6.3.2	Extra power fail detection when the battery switch-over function is disabled	26	8.13.2	Countdown timer interrupts	56
8.6.4	Battery backup supply	26	8.13.3	INT pulse shortening	56
8.7	Oscillator stop detection function	27	8.13.4	Watchdog timer interrupts	58
			8.13.5	Alarm interrupts	58
			8.13.6	Timestamp interrupts	58
			8.13.7	Battery switch-over interrupts	58

continued >>

8.13.8	Battery low detection interrupts	58
8.14	External clock test mode	59
8.15	STOP bit function	59
9	Interfaces	62
9.1	SPI-bus interface	62
9.1.1	Data transmission	63
9.2	I ² C-bus interface	66
9.2.1	Bit transfer	66
9.2.2	START and STOP conditions	66
9.2.3	System configuration	66
9.2.4	Acknowledge	67
9.2.5	I ² C-bus protocol	67
9.3	Bus communication and battery backup operation	70
10	Internal circuitry	71
11	Safety notes	71
12	Limiting values	72
13	Static characteristics	73
13.1	Current consumption characteristics, typical	75
13.2	Frequency characteristics	78
14	Dynamic characteristics	80
14.1	SPI-bus timing characteristics	80
14.2	I ² C-bus timing characteristics	82
15	Application information	84
16	Test information	84
16.1	Quality information	84
17	Package outline	85
18	Packing information	87
18.1	Tape and reel information	87
19	Soldering	87
19.1	Footprint information	87
20	Appendix	89
20.1	Real-Time Clock selection	89
21	Abbreviations	91
22	References	92
23	Revision history	93
24	Legal information	94
24.1	Data sheet status	94
24.2	Definitions	94
24.3	Disclaimers	94
24.4	Trademarks	95
25	Contact information	95
26	Tables	96
27	Figures	98
28	Contents	99

Please be aware that important notices concerning this document and the product(s) described herein, have been included in section 'Legal information'.

© NXP Semiconductors N.V. 2014.

All rights reserved.

For more information, please visit: <http://www.nxp.com>

For sales office addresses, please send an email to: salesaddresses@nxp.com

Date of release: 19 December 2014

Document identifier: PCF2127