

REVISIONS

P	LTR	DESCRIPTION	DATE	DWN	APVD
	D2	REVISED PER ECR-16-002372	21OCT2021	ED	WH

NOTES:

- 1 PACK IN ACCORDANCE WITH AMP SPEC 107-3275
- 2 100 TRAY PACK IN ACCORDANCE WITH AMP SPEC 107-3275
- 3 Au PLATING
GOLD THICKNESS FOR CONTACT IS 0.05um;
GOLD THICKNESS FOR BODY IS 0.05um.
- 4 ELECTRICAL CHARACTERISTICS
FREQUENCY RANGE: DC - 4 GHz
NOMINAL IMPEDANCE: 50 Ohm
INSULATION RESISTANCE: 1000 MOhm
WORKING VOLTAGE: 250 Volts RMS at Sea Level
DIELECTRIC WITHSTAND VOLTAGE: 750 Volts RMS Max
CONTACT RESISTANCE:
CENTRE CONTACT: 6.00 mOhm Max
OUTER CONTACT: 1.00 mOhm Max
- 5 MECHANICAL CHARACTERISTICS
DURABILITY: 500 Cycles Min
- 6 ENVIRONMENTAL CHARACTERISTICS
OPERATING TEMPERATURE: -65 to +165 DegC
- 7 FOR TECHNICAL DATA REFER TO YOUR LOCAL
TE CONNECTIVITY SALES OFFICE
- 8 ALL DIMENSIONS ARE NOMINAL FOR REFERENCE
ONLY UNLESS OTHERWISE STATED

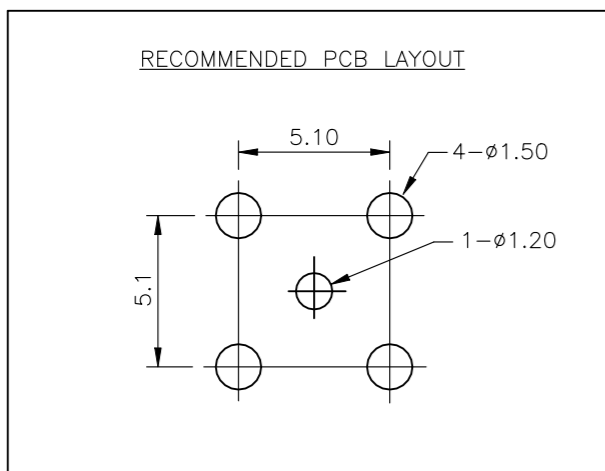
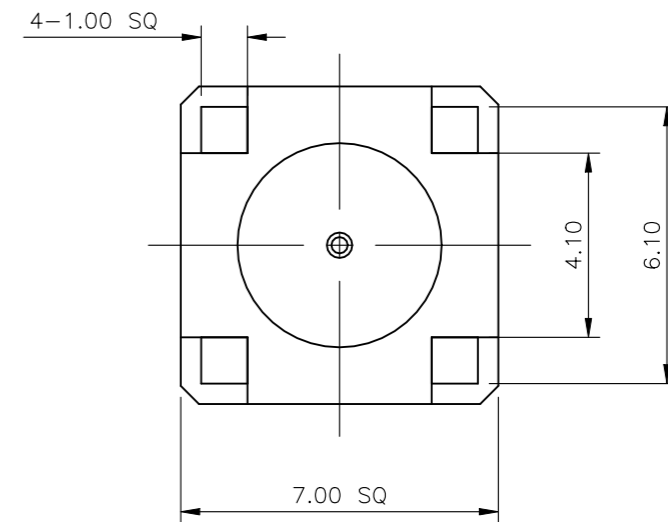
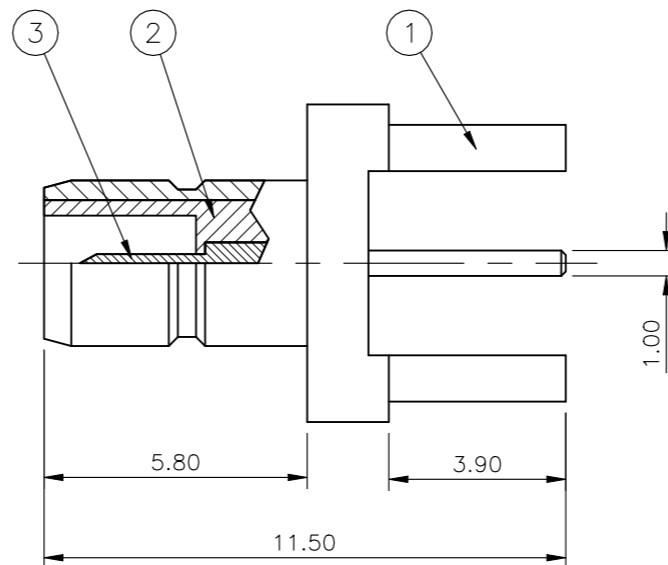

QTY	QTY PER ASSY	MATERIAL	DESCRIPTION	ITEM
1	1	BRASS	CONTACT	3
1	1	PTFE	INSULATION	2
1	1	BRASS	BODY	1
6--0	1--0	MATERIAL	DESCRIPTION	ITEM

THIS DRAWING IS A CONTROLLED DOCUMENT.		DWN J.SANDWELL 07SEPT05												
DIMENSIONS: mm		CHK S.PARLOW 07SEPT05												
TOLERANCES UNLESS OTHERWISE SPECIFIED:		APVD F.WHEELER-KING 07SEPT05												
<table border="1"> <tr><td>0 PLC</td><td>± -</td></tr> <tr><td>1 PLC</td><td>± 0.2</td></tr> <tr><td>2 PLC</td><td>± 0.1</td></tr> <tr><td>3 PLC</td><td>± -</td></tr> <tr><td>4 PLC</td><td>± -</td></tr> <tr><td>ANGLES</td><td>± -</td></tr> </table>		0 PLC				± -	1 PLC	± 0.2	2 PLC	± 0.1	3 PLC	± -	4 PLC	± -
0 PLC	± -													
1 PLC	± 0.2													
2 PLC	± 0.1													
3 PLC	± -													
4 PLC	± -													
ANGLES	± -													
MATERIAL SEE TABLE		FINISH -	SMB STRAIGHT PCB SOCKET 50 OHM											
		WEIGHT 0.000000	SIZE A3	CAGE CODE 00779	DRAWING NO C-1337482									
		CUSTOMER DRAWING			RESTRICTED TO -									
		SCALE NTS	SHEET 1 OF 1	REV D2										