

IRF7805QPbF

- Advanced Process Technology
- Ultra Low On-Resistance
- N Channel MOSFET
- Surface Mount
- Available in Tape & Reel
- 150°C Operating Temperature
- Lead-Free

Description

These HEXFET[®] Power MOSFET's in package utilize the latest processing techniques to achieve extremely low on-resistance per silicon area. Additional features of these HEXFET Power MOSFET's are a 150°C junction operating temperature, fast switching speed and improved repetitive avalanche rating. These benefits combine to make this design an extremely efficient and reliable device for use in a wide variety of applications. The efficient SO-8 package provides enhanced thermal characteristics making it ideal in a variety of power applications. This surface mount SO-8 can dramatically reduce board space and is also available in Tape & Reel.

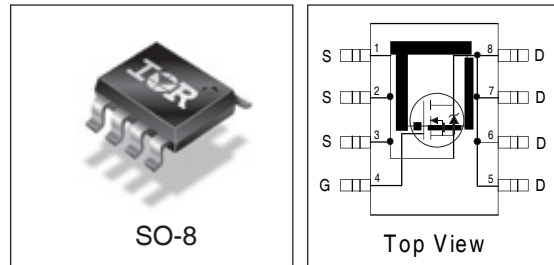

Device Features

	IRF7805Q
V_{DS}	30V
$R_{DS(on)}$	11m Ω
Qg	31nC
Qsw	11.5nC
Qoss	36nC

Base part number	Orderable part number	Package Type	Standard Pack		EOL Notice	Replacement Part Number
			Form	Quantity		
IRF7805QPbF	IRF7805QTRPbF	SO-8	Tape and Reel	4000	EOL 527	Please search the EOL part number on IR's website for guidance
	IRF7805QPbF	SO-8	Tube	95	EOL 529	

Absolute Maximum Ratings

	Parameter	Max.	Units
V_{DS}	Drain-to-Source Voltage	30	V
V_{GS}	Gate-to-Source Voltage	± 12	
$I_D @ T_A = 25^\circ\text{C}$	Continuous Drain Current, $V_{GS} @ 10\text{V}$	13	A
$I_D @ T_A = 70^\circ\text{C}$	Continuous Drain Current, $V_{GS} @ 10\text{V}$	10	
I_{DM}	Pulsed Drain Current ^①	100	
$P_D @ T_A = 25^\circ\text{C}$	Power Dissipation ^②	2.5	W
$P_D @ T_A = 70^\circ\text{C}$	Power Dissipation ^②	1.6	
	Linear Derating Factor	0.02	W/ $^\circ\text{C}$
T_J	Operating Junction and	-55 to + 150	$^\circ\text{C}$
T_{STG}	Storage Temperature Range		

Thermal Resistance

	Parameter	Typ.	Max.	Units
$R_{\theta JL}$	Junction-to-Drain Lead ^③	—	20	$^\circ\text{C}/\text{W}$
$R_{\theta JA}$	Junction-to-Ambient ^{③④}	—	50	

END OF LIFE

IRF7805QPbF

International
IR Rectifier

Static @ T_J = 25°C (unless otherwise specified)

	Parameter	Min.	Typ.	Max.	Units	Conditions
BV _{DSS}	Drain-to-Source Breakdown Voltage ^⑥	30	—	—	V	V _{GS} = 0V, I _D = 250μA
R _{DS(on)}	Static Drain-to-Source On-Resistance ^⑥	—	9.2	11	mΩ	V _{GS} = 4.5V, I _D = 7.0A ^②
V _{GS(th)}	Gate Threshold Voltage ^⑥	1.0	—	3.0	V	V _{DS} = V _{GS} , I _D = 250μA
I _{DSS}	Drain-to-Source Leakage Current	—	—	70	μA	V _{DS} = 30V, V _{GS} = 0V
		—	—	10		V _{DS} = 24V, V _{GS} = 0V
		—	—	150		V _{DS} = 24V, V _{GS} = 0V, T _J = 100°C
I _{GSS}	Gate-to-Source Forward Leakage	—	—	100	nA	V _{GS} = 12V
	Gate-to-Source Reverse Leakage	—	—	-100		V _{GS} = -12V
Q _g	Total Gate Charge	—	22	31	nC	V _{GS} = 5.0V
Q _{gs1}	Pre-V _{th} Gate-to-Source Charge	—	3.7	—		V _{DS} = 16V
Q _{gs2}	Post-V _{th} Gate-to-Source Charge	—	1.4	—		I _D = 7.0A
Q _{gd}	Gate-to-Drain Charge	—	6.8	—		
Q _{sw}	Switch Charge (Q _{gs2} + Q _{gd})	—	8.2	11.5		
Q _{oss}	Output Charge	—	3.0	3.6	nC	V _{DS} = 16V, V _{GS} = 0V
R _G	Gate Resistance	0.5	—	1.7	Ω	
t _{d(on)}	Turn-On Delay Time	—	16	—	ns	V _{DD} = 16V, V _{GS} = 4.5V ^③
t _r	Rise Time	—	20	—		I _D = 7.0A
t _{d(off)}	Turn-Off Delay Time	—	38	—		R _G = 2Ω
t _f	Fall Time	—	16	—		Resistive Load

Diode Characteristics

	Parameter	Min.	Typ.	Max.	Units	Conditions
I _S	Continuous Source Current (Body Diode) ^①	—	—	2.5	A	MOSFET symbol showing the integral reverse p-n junction diode.
I _{SM}	Pulsed Source Current (Body Diode)	—	—	106		
V _{SD}	Diode Forward Voltage ^⑥	—	—	1.2	V	T _J = 25°C, I _S = 7.0A, V _{GS} = 0V
Q _{rr}	Reverse Recovery Charge ^④	—	88	—	ns	di/dt = 700A/μs V _{DS} = 16V, V _{GS} = 0V, I _S = 7.0A
Q _{rr(s)}	Reverse Recovery Charge (with Parallel Schottky) ^④	—	55	—	nC	di/dt = 700A/μs (with 10BQ040) V _{DS} = 16V, V _{GS} = 0V, I _S = 7.0A

Notes:

- ① Repetitive rating; pulse width limited by max. junction temperature.
- ② Pulse width ≤ 300 μs; duty cycle ≤ 2%.
- ③ When mounted on 1 inch square copper board, t < 10 sec.
- ④ Typ = measured - Q_{oss}.
- ⑤ R_g is measured at T_J of approximately 90°C.
- ⑥ Devices are 100% tested to these parameters.

END OF LIFE

Typical Characteristics

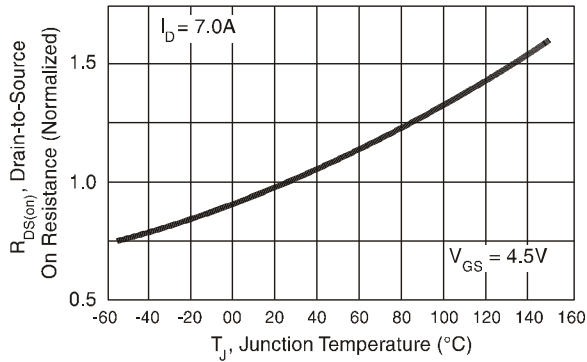

Fig 1. Normalized On-Resistance vs. Temperature

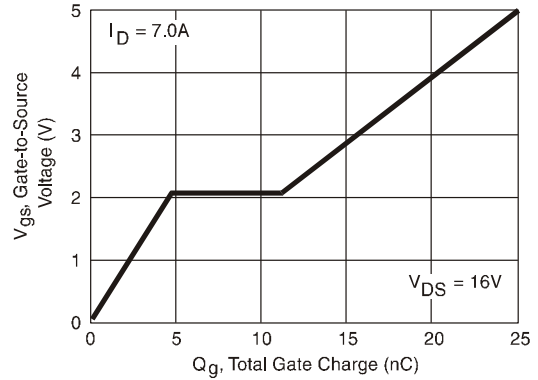

Fig 2. Typical Gate Charge vs. Gate-to-Source Voltage

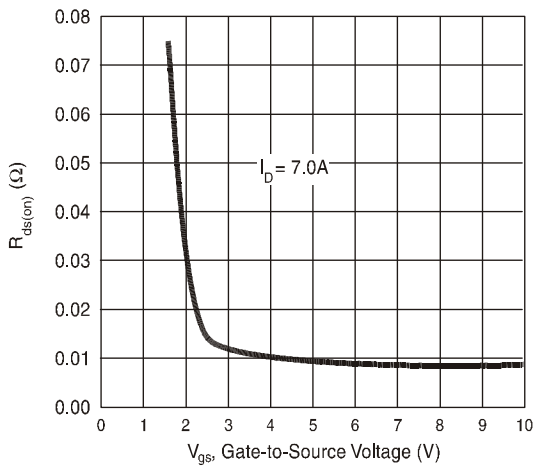

Fig 3. Typical $R_{DS(on)}$ vs. Gate-to-Source Voltage

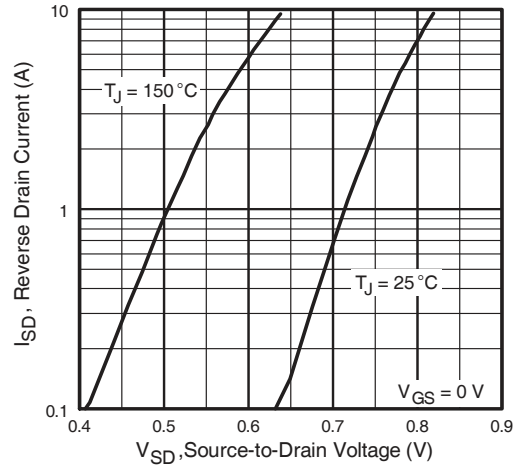

Fig 4. Typical Source-Drain Diode Forward Voltage

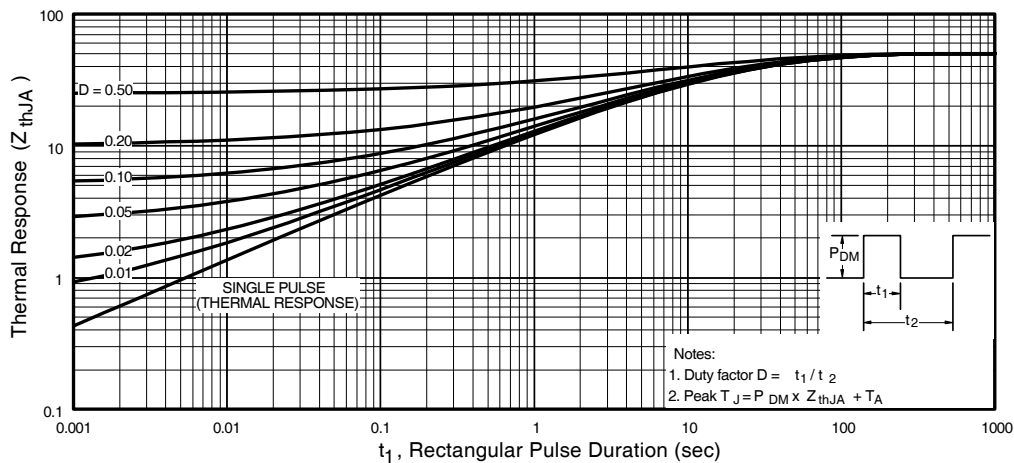

Figure 5. Maximum Effective Transient Thermal Impedance, Junction-to-Ambient

END OF LIFE

IRF7805QPbF

International
IR Rectifier

SO-8 Package Outline

Dimensions are shown in millimeters (inches)

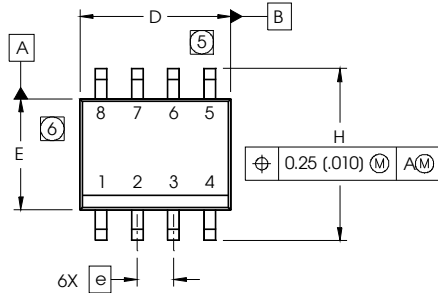

DIM	INCHES		MILLIMETERS	
	MIN	MAX	MIN	MAX
A	.0532	.0688	1.35	1.75
A1	.0040	.0098	0.10	0.25
b	.013	.020	0.33	0.51
c	.0075	.0098	0.19	0.25
D	.189	.1968	4.80	5.00
E	.1497	.1574	3.80	4.00
e	.050 BASIC		1.27 BASIC	
e1	.025 BASIC		0.635 BASIC	
H	.2284	.2440	5.80	6.20
K	.0099	.0196	0.25	0.50
L	.016	.050	0.40	1.27
y	0°	8°	0°	8°

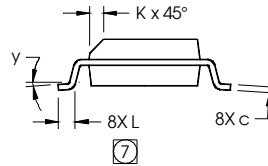
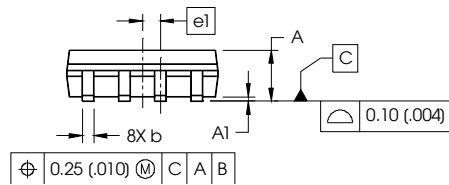

NOTES:

1. DIMENSIONING & TOLERANCING PER ASME Y14.5M-1994.
2. CONTROLLING DIMENSION: MILLIMETER
3. DIMENSIONS ARE SHOWN IN MILLIMETERS (INCHES).
4. OUTLINE CONFORMS TO JEDEC OUTLINE MS-012AA.
- ⑤ DIMENSION DOES NOT INCLUDE MOLD PROTRUSIONS. MOLD PROTRUSIONS NOT TO EXCEED 0.15 (.006).
- ⑥ DIMENSION DOES NOT INCLUDE MOLD PROTRUSIONS. MOLD PROTRUSIONS NOT TO EXCEED 0.25 (.010).
- ⑦ DIMENSION IS THE LENGTH OF LEAD FOR SOLDERING TO A SUBSTRATE.

FOOTPRINT

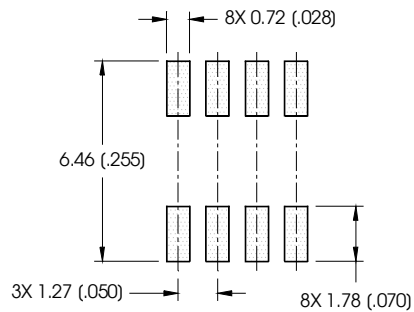

SO-8 Part Marking

EXAMPLE: THIS IS AN IRF7101 (MOSFET)

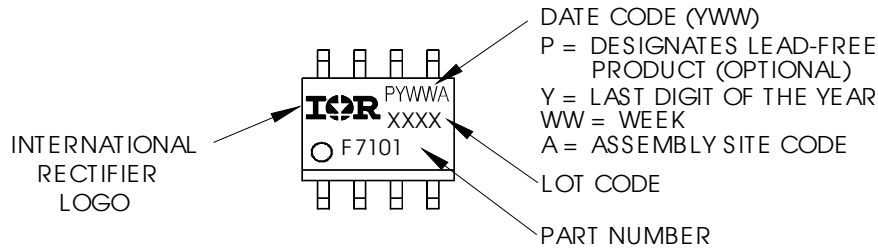

Notes:

1. For an Automotive Qualified version of this part please see : <http://www.irf.com/product-info/autof/>
2. For the most current drawing please refer to IR website at <http://www.irf.com/package/>

END OF LIFE

International
IR Rectifier

IRF7805QPbF

SO-8 Tape and Reel

Dimensions are shown in millimeters (inches)

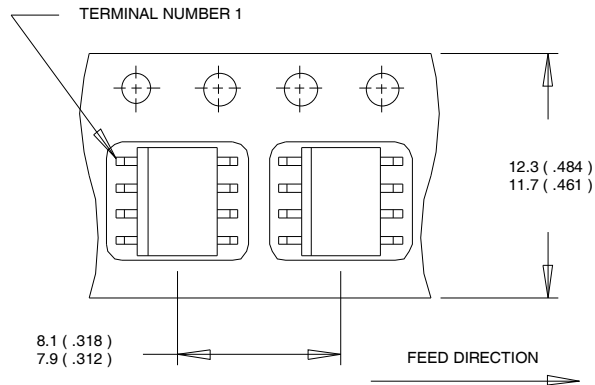

- NOTES:
1. CONTROLLING DIMENSION : MILLIMETER.
 2. ALL DIMENSIONS ARE SHOWN IN MILLIMETERS(INCHES).
 3. OUTLINE CONFORMS TO EIA-481 & EIA-541.

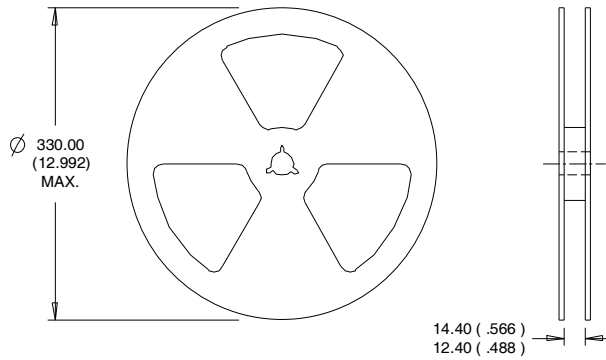

- NOTES :
1. CONTROLLING DIMENSION : MILLIMETER.
 2. OUTLINE CONFORMS TO EIA-481 & EIA-541.

For the most current drawing please refer to IR website at <http://www.irf.com/package/>

END OF LIFE

IRF7805QPbF

International
IOR Rectifier

Qualification Information[†]

Qualification level	Industrial [†]	
	(per JEDEC JESD47F ^{††} guidelines)	
Moisture Sensitivity Level	SO-8	MSL1 (per JEDEC J-STD-020D ^{††})
RoHS Compliant	Yes	

[†] Qualification standards can be found at International Rectifier's web site
<http://www.irf.com/product-info/reliability>

^{††} Applicable version of JEDEC standard at the time of product release.

Revision History

Date	Comments
8/19/2014	• Added ordering information to reflect the End-Of-life

International
IOR Rectifier

IR WORLD HEADQUARTERS: 101 N. Sepulveda Blvd., El Segundo, California 90245, USA
To contact International Rectifier, please visit <http://www.irf.com/whoto-call/>

www.irf.com