



TO-92S



Pin Definition:

1. V_{DD}
2. GND
3. Output

Description

TSH181, Hall-Effect sensor, designed for electronic commutation of brush-less DC motor applications. The device includes an on-chip Hall voltage generator for magnetic sensing, a comparator that amplifies the Hall Voltage, and a Schmitt trigger to provide switching hysteresis for noise rejection, and open collector output. An internal band gap regulator is used to provide temperature compensated supply voltage for internal circuits and allows a wide operating supply range. The device is identical except for magnetic switch points. The device includes on a single silicon chip a voltage regulator, Hall-voltage generator, small-signal amplifier, chopper stabilization, Schmitt trigger, open-collector output to sink up to 25mA. A south pole of sufficient strength will turn the output on. The North Pole is necessary to turn the output off. An on-board regulator permits operation with supply voltages of 3.5V to 20 V.

Features

- Temperature compensation.
- Wide operating voltage range.
- Open-Collector pre-driver.
- Reverse bias protection on power supply pin.
- 100% at 125°C "Hot Test"

Ordering Information

Part No.	Package	Packing
TSH181CT B0G	TO-92S	1Kpcs / Bulk Bag

Note: "G" denote for Halogen Free Product

Application

- High temperature Fan motor
- 3 phase BLDC motor application
- Fan motor application
- Speed sensing
- Revolution counting

Absolute Maximum Rating ($T_a = 25^\circ\text{C}$ unless otherwise noted)

Characteristics	Limit	Value	Unit
Supply voltage	V_{CC}	20	V
Output Voltage	V_{OUT}	30	V
Reverse voltage	$V_{CC/OUT}$	-20	V
Magnetic flux density		Unlimited	Gauss
Output current	I_{OUT}	25	mA
Operating Temperature Range	T_{OPR}	-40 to +125	$^\circ\text{C}$
Storage temperature range	T_{STG}	-55 to +150	$^\circ\text{C}$
Maximum Junction Temp	T_J	150	$^\circ\text{C}$
Thermal Resistance - Junction to Ambient	θ_{JA}	206	$^\circ\text{C/W}$
Thermal Resistance - Junction to Case	θ_{JC}	148	$^\circ\text{C/W}$
Package Power Dissipation	P_D	606	mW

Note: Do not apply reverse voltage to V_{CC} and V_{OUT} Pin, It may be caused for Miss function or damaged device.

Block Diagram

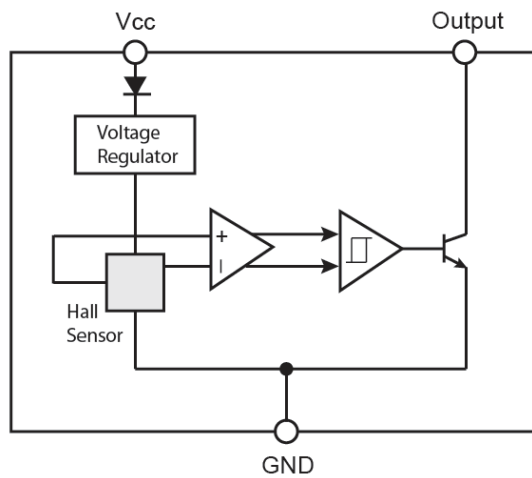

Typical Application Circuit

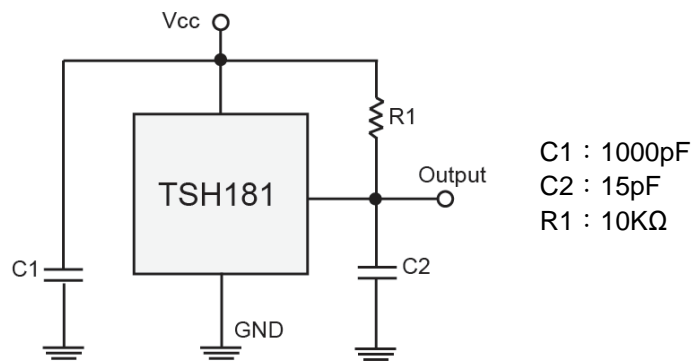

Electrical Specifications (DC Operating Parameters : $T_A=+25^{\circ}\text{C}$, $V_{CC}=12\text{V}$)

Parameters	Test Conditions	Min	Typ	Max	Units
Supply Voltage	Operating	3.5	--	20	V
Supply Current	$B < B_{OP}$	--	4	8	mA
Output Saturation Voltage	$I_{OUT} = 10\text{mA}$, $B > B_{OP}$	--	--	700	mV
Output Leakage Current	I_{OFF} $B < B_{RP}$, $V_{OUT} = 12\text{V}$	--	--	10	uA
Output Rise Time	$R_L = 820\Omega$, $C_L = 20\text{pF}$	--	--	1.5	uS
Output Fall Time	$R_L = 820\Omega$; $C_L = 20\text{pF}$	--	--	1.5	uS

Magnetic Specifications

Parameters	Test Conditions	Min	Typ	Max	Units
Operate Point		5	--	90	Gauss
Release Point		-90	--	-5	Gauss
Hysteresis		--	100	--	Gauss

Note: 1G (Gauss) = 0.1mT (millitesta)

Output Behavior versus Magnetic Pole

DC Operating Parameters: $T_A = -40$ to 125°C , $V_{CC} = 3.5$ to 20V

Parameter	Test condition	OUT
North pole	$B > B_{OP}$	Open
South pole	$B < B_{RP}$	Low

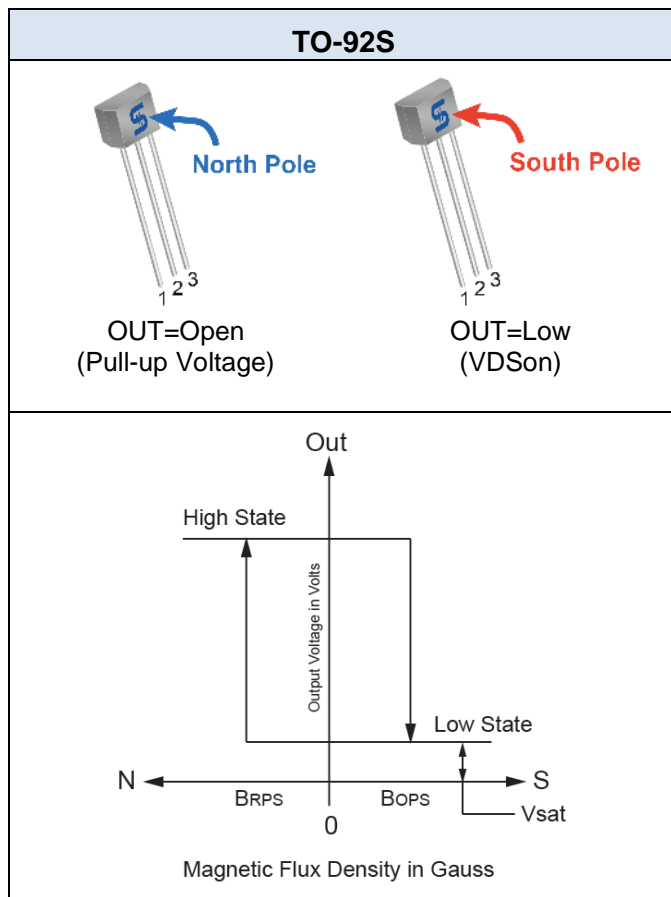

Characteristic Performance

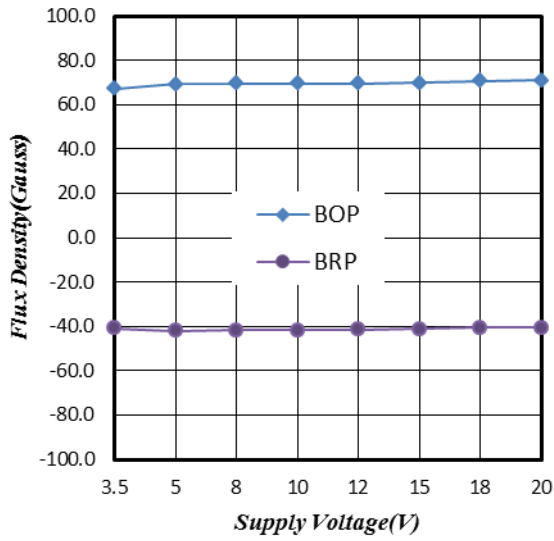

Figure 1. Supply Voltage vs. Flux Density

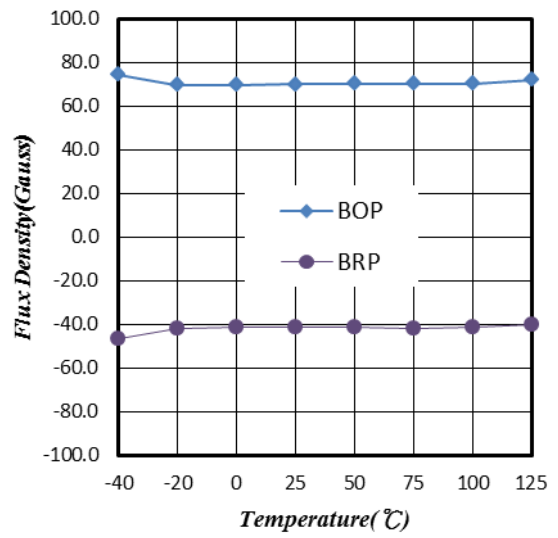

Figure 2. Temperature vs. Flux Density

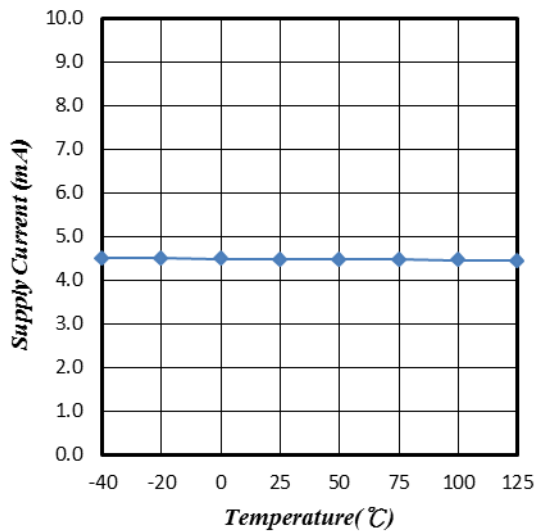

Figure 3. Supply Voltage vs. Output Voltage

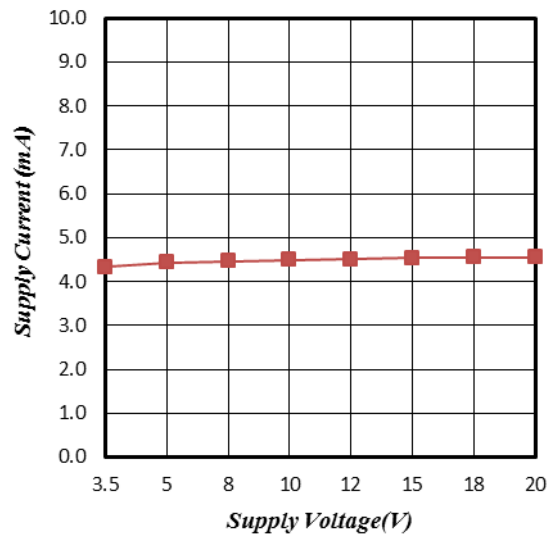

Figure 4. Temperature vs. Output Voltage

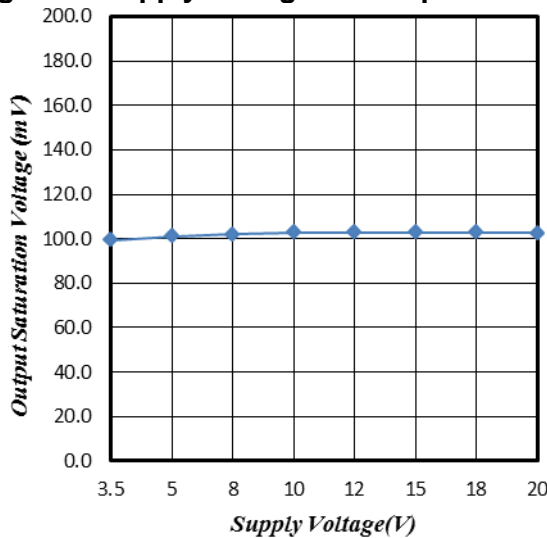

Figure 5. Supply Voltage vs. Leakage Current

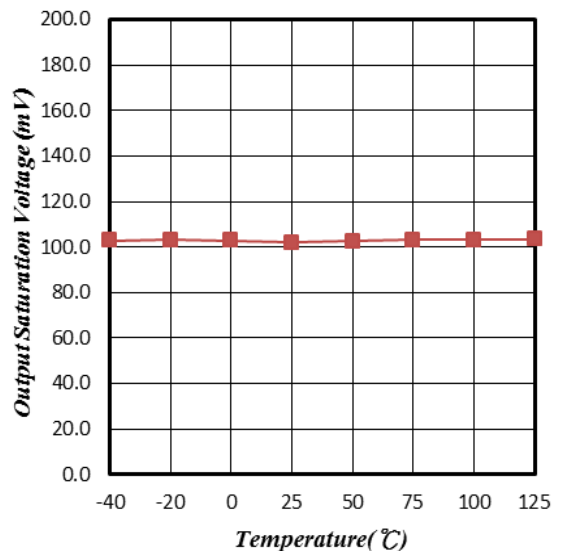

Figure 6. Power Dissipation vs. Temperature

Characteristic Performance

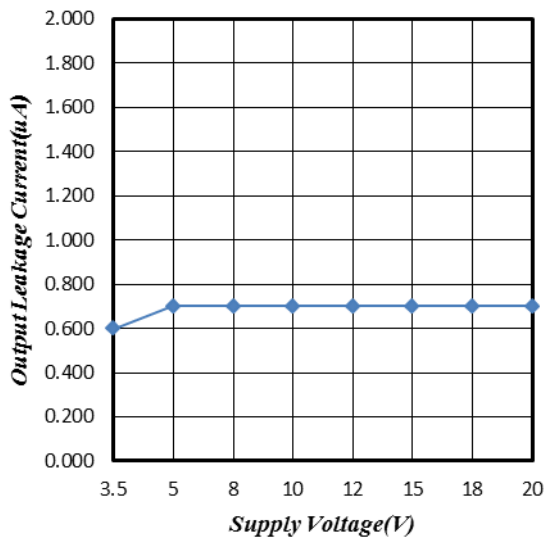

Figure 7. Temperature vs. Supply Current

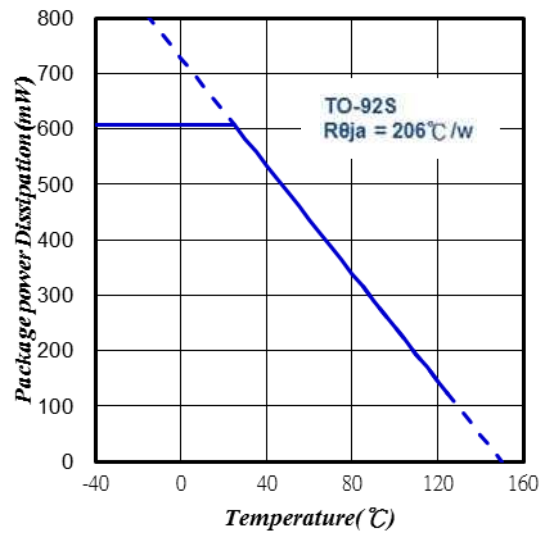

Figure 8. Temperature vs. Power Dissipation

TO-92S Mechanical Drawing



Unit: Millimeters

Marking Diagram

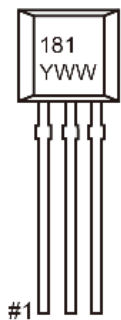

181 = Device Code
Y = Year Code
WW = Week Code (01~52)

Notice

Specifications of the products displayed herein are subject to change without notice. TSC or anyone on its behalf, assumes no responsibility or liability for any errors or inaccuracies.

Information contained herein is intended to provide a product description only. No license, express or implied, to any intellectual property rights is granted by this document. Except as provided in TSC's terms and conditions of sale for such products, TSC assumes no liability whatsoever, and disclaims any express or implied warranty, relating to sale and/or use of TSC products including liability or warranties relating to fitness for a particular purpose, merchantability, or infringement of any patent, copyright, or other intellectual property right.

The products shown herein are not designed for use in medical, life-saving, or life-sustaining applications. Customers using or selling these products for use in such applications do so at their own risk and agree to fully indemnify TSC for any damages resulting from such improper use or sale.