

PART NUMBER	REV	FIRST USED
680766-1	B	122500-1
680766-2	B	565435-5

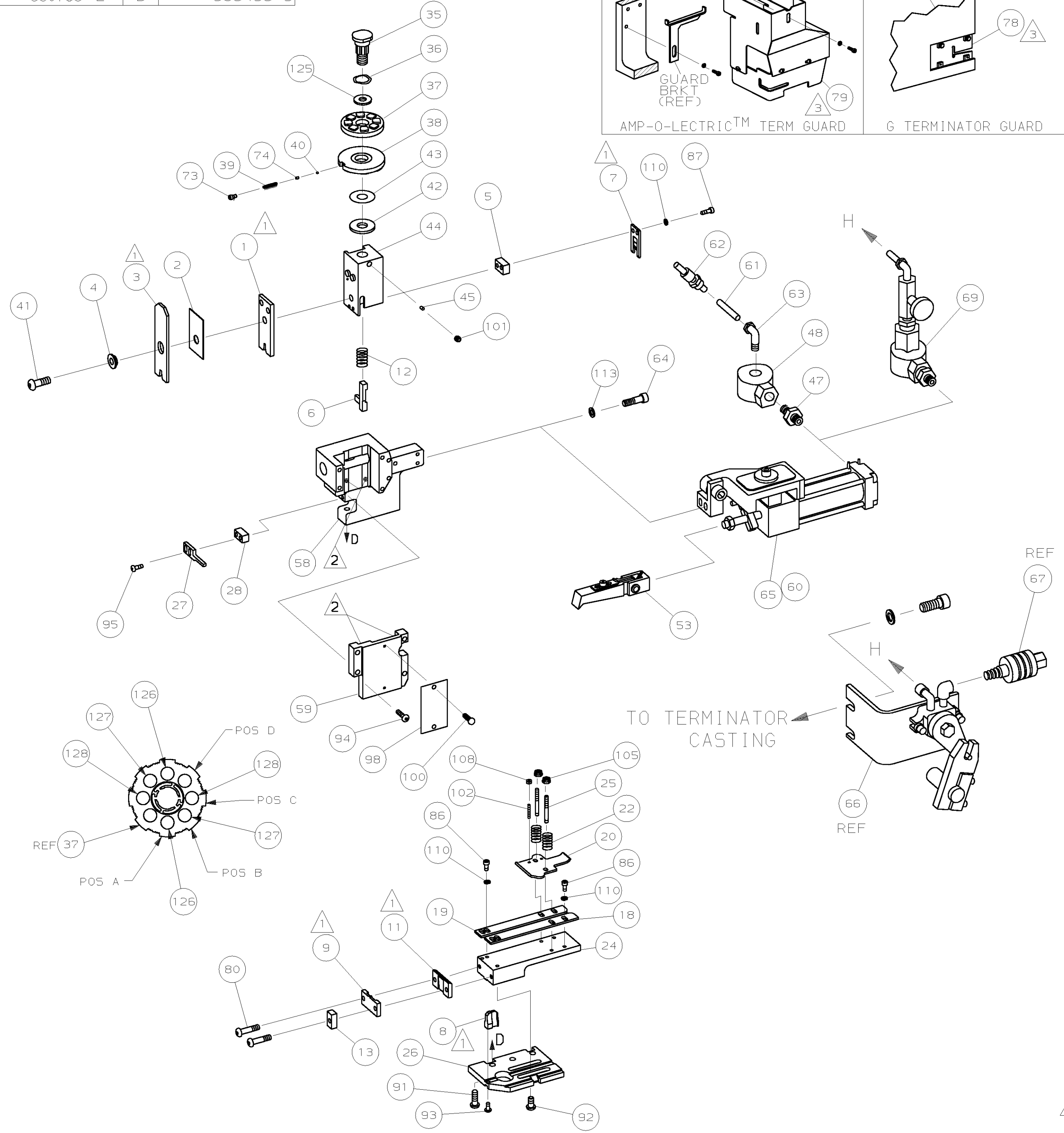
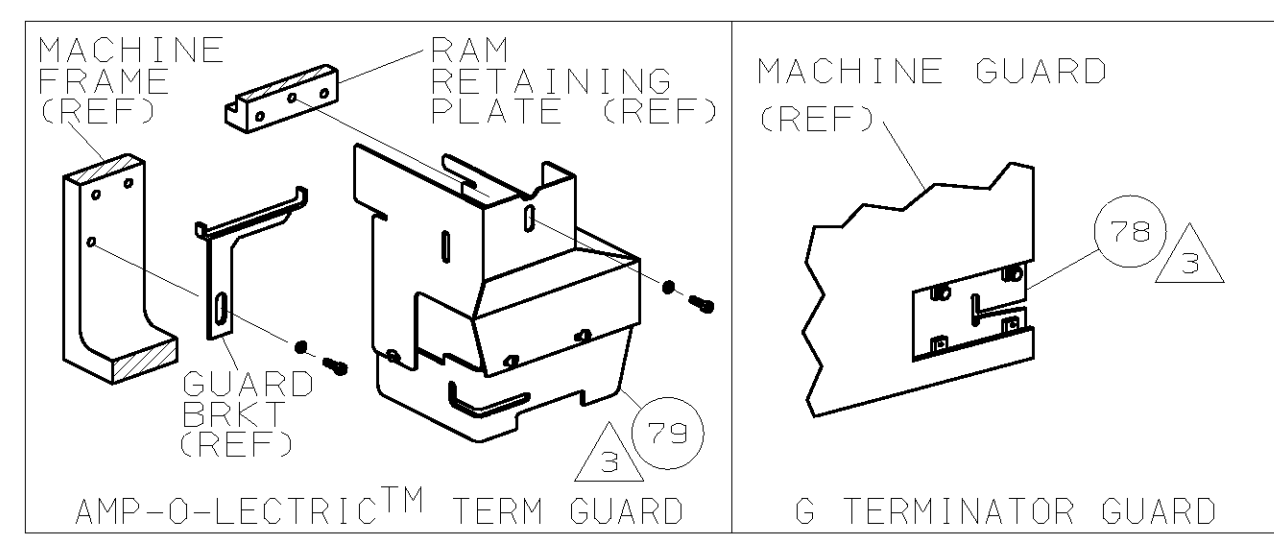

- ① RECOMMENDED SPARE PARTS.
- ② GREASE LIGHTLY.
- ③ GUARD MUST BE IN PLACE WHEN OPERATING APPLICATOR IN A BENCH MACHINE.
- ④ SEE DRAWING FOR COMPONENTS
- ⑤ ITEM 78 USED WITH G TERMINATOR ONLY.

TERMINAL NAME: .250 SER. FAST-ON™ TAB		928949	
PAD LTR	CRIMP HEIGHT	WIRE SIZE	
A	.085 ±.002 [2.17 ±0.05mm]	4.0mm	
B	.081 ±.002 [2.06 ±0.05mm]	3.5mm	
C	.077 ±.002 [1.95 ±0.05mm]	3.0mm	
D	NOT	USED	
CRIMP	SIZE	TYPE	RANGE
WIRE	.140 [3.56mm]	F	3.0-4.0mm ²
INSUL	.210 [5.33mm]	F	∅3.3-4.5mm

QTY	REV	U/M	DWG SIZE	PART NO	DESCRIPTION	ITEM NO
2	2	-	C	8-354778-2	PIN, WIRE DISC (.2905)C	129
2	2	-	C	7-354778-4	PIN, WIRE DISC (.2865)B	127
2	2	-	C	6-354778-6	PIN, WIRE DISC (.2825)A	126
1	1	-	A	986950-1	WASHER, FLAT PRECISION	125
1	1	-	A	217238-1	GENERAL INSTRUCTION PACKAGE	124
1	1	-	-	4088039	EF APPL INST 408-8039	123
						122
						121
						120
						119
						118
						117
						116
						115
						114
2	2	-	A	21024-5	WASHER, LOCK (#10) AIR ASSY	113
						112
4	4	-	A	21024-4	WASHER, LOCK (NO. 8) SHEAR BL	110
						109
2	2	-	A	21018-4	NUT, HEX (4-40) DRAG	108
						107
						106
2	2	-	A	21022-2	NUT, HEX 5L (8-32) DRAG STUD	105
						104
						103
2	2	-	A	2-21006-6	SCR, SKT SET (4-40x.62) DRAG	102
1	1	-	A	21009-2	SCR, SKT SET (1/4-20x.25) RAM	101
2	2	-	A	21017-2	SCR, DRIVE (#2x.19) ID PLATE	100
						99
1	1	-	B	461264-1	PLATE, IDENTIFICATION	98
						97
						96
2	2	-	A	2-21002-2	SCR, BHC (8-32x.50) STRIPPER	95
4	4	-	A	2-21002-9	SCR, BHC (10-32x.75) CAP	94
1	1	-	A	22733-8	SCR, BHC (8-32x.38 LW) ANVIL	93
4	4	-	A	3-21002-3	SCR, BHC (1/4-20x.50) ST 6D PL	92
3	3	-	A	2-22733-8	SCR, BHC (1/4-20x.62) H5G	91
						90
						89
						88
2	2	-	A	3-21000-0	SCR, SHC (8-32x.88) SLUG BLADE	87
4	4	-	A	2-21000-6	SCR, SHC (8-32x.38) STRIP GUIDE	86
						85
						84
						83
						82
						81
2	2	-	A	3-21002-0	SCR, BHC (10-32x.88) SHEAR PL	80
1	-	-	A	455750-8	GUARD ASSY	79
-	REF	-	A	679532-1	INSERT, GUARD	78
						77
						76
						75
1	1	-	A	690603-1	SPRING, ASSIST	74
1	1	-	A	23030-1	SCR, SKT CAP (6-32x.25) CP DSC	73
						72
						71

QTY	REV	U/M	DWG SIZE	PART NO	DESCRIPTION	ITEM NO
-2	-1	U/M				

QTY	REV	U/M	DWG SIZE	PART NO	DESCRIPTION	ITEM NO	
-1					LEADMAKER & BENCH MODEL G		
-2					BENCH MODEL K		
					AIR FEED		
					AIR FEED		
④	1	-	C	692655-5	AIR FEED VALVE ASSY	70	
						69	
						68	
REF	-	-	A	24042-2	VALVE, SHUT OFF	67	
④	REF	-	C	692655-6	AIR FEED VALVE ASSY	66	
④	1	-	B	1-460277-5	AIR FEED ASSY (2 INCH)	65	
2	2	-	A	3-21000-9	SCR, SHC (10-32x1.00) AIR ASSY	64	
-	1	-	A	980285-2	ELBOW, SWIVEL 1/8 NPT - 1/4 T	63	
-	1	-	A	23238-1	QUICK DISCONNECT	62	
-	12.00	IN	A	27319-4	TUBING, POLY-FLO ∅.25	61	
-	1	-	-	1-460277-9	AIR FEED ASSY (2 IN)	60	
1	1	-	C	454220-1	CAP, RAM	59	
1	1	-	D	453736-1	HOUSING	58	
						57	
						56	
						55	
						54	
④	1	1	-	B	460680-1	FEED FINGER ASSY	53
						52	
						51	
						50	
						49	
-	1	-	A	22374-7	VALVE, QUICK EXHAUST	48	
-	1	-	A	22304-1	NIPPLE, HEX 1/8 NPT	47	
						46	
1	1	-	A	690191-1	PLUG, NYLON	45	
1	1	-	C	455674-1	RAM	44	
1	1	-	A	690125-1	WASHER, LAMINATED	43	
1	1	-	A	690124-1	WASHER, RAM	42	
1	1	-	A	7-21002-9	BOLT, CRIMPER (5/16-24x1.00)	41	
1	1	-	A	23241-6	BALL, STEEL	40	
1	1	-	A	690170-1	SPRING, COMPRESSION	39	
1	1	-	C	690142-1	DISC, INSULATION	38	
1	1	-	D	354777-1	WIRE DISC, PLASTIC	37	
1	1	-	A	22480-5	WASHER, SPRING	36	
1	1	-	B	690212-1	POST, RAM	35	
						34	
						33	
						32	
						31	
						30	
						29	
1	1	-	B	3-690451-2	SPACER, STRIPPER	28	
1	1	-	A	240639-1	STRIPPER	27	
1	1	-	D	455676-1	PLATE, BASE	26	
2	2	-	A	22354-8	DRAG, STUD	25	
1	1	-	B	455678-1	PLATE, STRIP GUIDE	24	
						23	
2	2	-	A	4-22281-1	SPRING, DRAG	22	
						21	
1	1	-	A	454177-1	DRAG, STOCK	20	
1	1	-	B	1-458030-3	GUIDE, STRIP (REAR)	19	
1	1	-	C	1-458031-3	GUIDE, STRIP (FRONT)	18	
						17	
						16	
						15	
						14	
1	1	-	C	690481-4	SPACER, HOLD DOWN	13	
1	1	-	A	23846-1	SPRING, HOLD DOWN	12	
1	1	-	B	240644-1	PLATE, REAR SHEAR	11	
						10	
④	1	1	-	B	690482-3	PLATE, FRONT SHEAR	9
④	1	1	-	D	3-356038-1	ANVIL	8
④	1	1	-	B	690474-3	BLADE, SLUG	7
④	1	1	-	D	6-455892-1	HOLD DOWN, TERMINAL	6
1	1	-	C	7-240641-8	SPACER, SLUG BLADE	5	
1	1	-	B	238009-1	SPACER, BLOCK CRIMPER	4	
④	1	1	-	C	1-456134-1	CRIMPER, INSULATION	3
④	1	1	-	B	1-455888-0	SPACER, CRIMPER	2
④	1	1	-	C	456411-9	CRIMPER, WIRE	1

QTY	REV	U/M	DWG SIZE	PART NO	DESCRIPTION	ITEM NO
-2	-1	U/M				

DIMENSIONS IN INCHES. DO NOT SCALE PRINT. TOLERANCES UNLESS OTHERWISE SPECIFIED:
 2 PLC DEC ±.25
 3 PLC DEC ±.
 4 PLC DEC ±.
 ANGLES ±.
 SURF TEXTURE: ✓
 REMOVE BURRS, BREAK SHARP EDGES R.015 MAX

MATL - HT TR - FIN -

DR K. STAKEM 15JAN99 APP T. ELBIN 15JAN99
 CHK 15JAN99 REL -
 C. ERISMAN

AMP AMP Incorporated Harrisburg, PA 17105-3608

NAME: END FEED HDM APPLICATOR MACHINE REF: MINI APPL

SCALE: - DWG NO: 680766 SHEET: 1 OF 1 REV: B

CASE CODE: 00779 CUSTOMER AND ASSEMBLY DRAWING

THIS DRAWING IS A CONTROLLED DOCUMENT.

THIS DRAWING IS UNRELEASED FOR PUBLICATION BY AMP INCORPORATED. ALL RIGHTS RESERVED.

LOC A
 DIST 66