

# TCC-106

## Six-Output PTIC Control IC

### Introduction

ON Semiconductor's PTIC Controller IC is a six-output high-voltage digital to analog control IC specifically designed to control and bias ON Semiconductor's Passive Tunable Integrated Circuits (PTICs).

These tunable capacitive circuits are intended for use in mobile phones and dedicated RF tuning applications. The implementation of ON Semiconductor's tunable circuits in mobile phones enables significant improvement in terms of antenna radiated performance.

The tunable capacitors are controlled through a bias voltage ranging from 2 V to 20 V. The TCC-106 high-voltage PTIC control IC has been specifically designed to cover this need, providing six independent high-voltage outputs that control up to six different tunable PTICs in parallel. The device is fully controlled through a multi-protocol digital interface.

### Key Features

- Controls ON Semiconductor's PTIC Tunable Capacitors
- Compliant with Timing Needs of Cellular and Other Wireless System Requirements
- Integrated Boost Converter with 6 Programmable Outputs (up to 24 V)
- Low Power Consumption
- Auto-detection of SPI (30- or 32-bit) or MIPI RFFE Interfaces (1.2 V or 1.8 V)
- Available in WLCSP (RDL ball arrays) and for Stand-alone or Module Integration
- This is a Pb-Free Device

### Typical Applications

- Multi-band, Multi-standard, Advanced and Simple Mobile Phones
- Tunable Antenna Matching Networks
- Compatible with Closed-loop and Open-loop Antenna Tuner Applications



**ON Semiconductor®**

[www.onsemi.com](http://www.onsemi.com)



**RDL Ball Array  
CASE 567HL**

### MARKING DIAGRAM

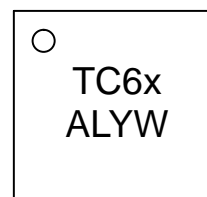

RDL

TC6 = Product Code  
x = MIPI ID  
A = Assembly Location  
L = Wafer Lot Code  
Y = Year Code  
W = Week Code  
O = Pin 1 Marker

### ORDERING INFORMATION

See detailed ordering and shipping information in the package dimensions section on page 23 of this data sheet.

# TCC-106

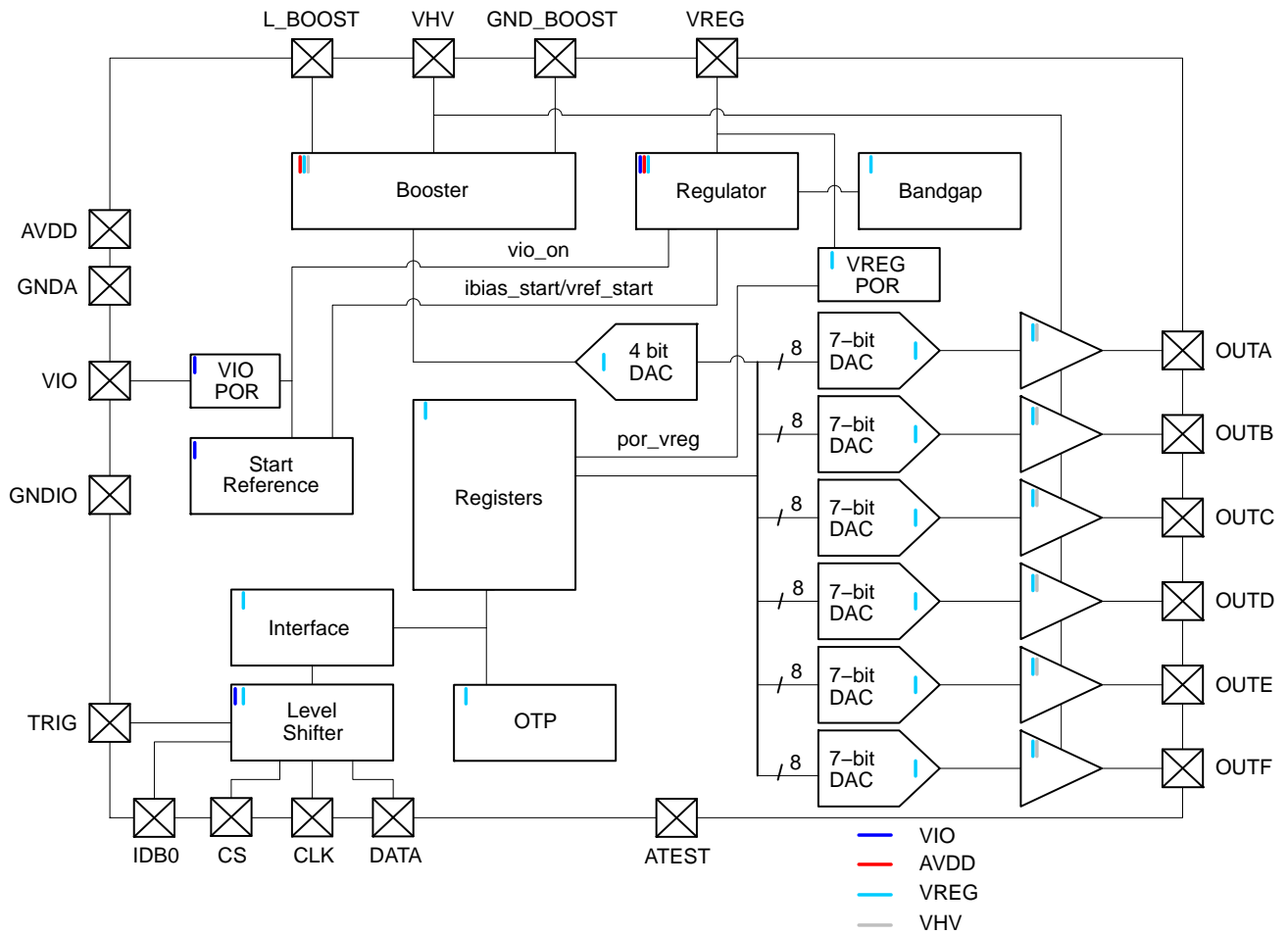

Figure 1. Control IC Functional Block Diagram

# TCC-106

## RDL Pin Out

**Table 1. PAD DESCRIPTIONS**

Bump	Name	Type	Description	Max Voltage (Note 1)	RDL
1	L_BOOST	AOH	Boost Inductor	25	B4
2	AVDD	P	Analog Supply	5.5	B3
3	GNDA	P	Analog Ground	0	C3
4	TRIG	DIO	Trigger Signal Input (Note 2)	VIO	C4
5	CLK	DI	MIPI RFFE / SPI Clock	VIO	D4
6	CS	DI	Chip Select for SPI	VIO	D3
7	DATA	DIO	Digital IO (SPI and MIPI RFFE)	VIO	E4
8	VIO	P	Digital IO Supply	3	E3
9	IDB0	DI	MIPI RFFE ID Bit 0 (Note 3)	VIO	C2
10	GNDIO	P	Digital IO Ground	VIO	D2
11	OUTA	AOH	High Voltage Output A	VHV	E2
12	OUTB	AOH	High Voltage Output B	VHV	E1
13	OUTC	AOH	High Voltage Output C	VHV	D1
14	OUTD	AOH	High Voltage Output D	VHV	C1
15	OUTE	AOH	High Voltage Output E	VHV	B1
16	OUTF	AOH	High Voltage Output F	VHV	A1
17	ATEST	AO	Analog Test Out (Note 4)	VREG	B2
18	VREG	AO	Regulator Output	3.6	A2
19	GND_BOOST	P	Ground for Booster	0	A3
20	VHV	AOH / AIH	Boost High Voltage can be Forced Externally	25	A4

1. For information only.
2. To be grounded when not in use.
3. This pin has to be connected to either GNDIO or VIO level, even if only SPI protocol is used. Never let it float.
4. To be grounded in normal operation.

## Electrical Performance Specifications

**Table 2. ABSOLUTE MAXIMUM RATINGS**

Symbol	Parameter	Rating	Unit
AVDD	Analog Supply Voltage	-0.3 to +6.0	V
VIO	IO Reference Supply Voltage	-0.3 to +3.6	V
V <sub>I/O</sub>	Input Voltage Logic Lines (DATA, CLK, CS)	-0.3 to VIO+0.3	V
V <sub>HVH</sub>	VHV Maximum Voltage	-0.3 to 30	V
V <sub>ESD (HBM)</sub>	Human Body Model, JESD22-A114, All I/O	2,000	V
V <sub>ESD (MM)</sub>	Machine Model, JESD22-A115	200	V
T <sub>STG</sub>	Storage Temperature	-55 to +150	°C
T <sub>AMB_OP_MAX</sub>	Max Operating Ambient Temperature without Damage	+110	°C

Stresses exceeding those listed in the Maximum Ratings table may damage the device. If any of these limits are exceeded, device functionality should not be assumed, damage may occur and reliability may be affected.

Table 3. RECOMMENDED OPERATING CONDITIONS

Symbol	Parameter	Rating			Unit
		Min	Typ	Max	
T <sub>AMB_OP</sub>	Operating Ambient Temperature	-30	-	+85	°C
T <sub>J_OP</sub>	Operating Junction Temperature	-30	-	+125	°C
AVDD	Analog Supply Voltage	2.3	-	5.5	V
VIO	IO Reference Supply Voltage	1.1	-	3.0	V

**Table 4. DC CHARACTERISTICS** (T<sub>A</sub> = -30 to +85°C; V<sub>OUTX</sub> = 15 V for each output; 2.3 V < AVDD < 5.5 V; 1.1 V < VIO < 3.0 V; R<sub>LOAD</sub> = equivalent series load of 5.6 kohm and 2.7 nF; C<sub>HV</sub> = 22 nF; L<sub>BOOST</sub> = 15 μH; TRIG pin grounded; unless otherwise specified)

Symbol	Parameter	Min	Typ	Max	Unit	Comment
--------	-----------	-----	-----	-----	------	---------

**SHUTDOWN MODE**

I <sub>AVDD</sub>	AVDD Supply Current	-	-	1.5	μA	VIO Supply is Low
I <sub>L_BOOST</sub>	L_BOOST Leakage	-	-	1.5		
I <sub>BATT</sub>	Battery Current	-	-	2.5		
I <sub>VIO</sub>	VIO Supply Current	-1	-	1		
I <sub>CLK</sub>	CLK Leakage	-1	-	1		
I <sub>DATA</sub>	DATA Leakage	-1	-	1		

**ACTIVE MODE**

I <sub>BATT</sub>	Average battery current, 3 outputs actively switching 16 V for 1205 μs to 2 V for 1705 μs to 8 V for 1705 μs and 3 outputs are @ 16 V steady state	-	1,760	2,350	μA	At VHV = 20 V AVDD = 3.3 V
I <sub>BATT_SS0</sub>	Average battery current, 6 outputs @ 0 V steady state	-	800	1,130		At VHV = 20 V AVDD = 3.3 V
I <sub>BAT_SS2</sub>	Average battery current, 6 outputs @ 2 V steady state	-	850	1,200	μA	At VHV = 20 V AVDD = 3.3 V
I <sub>BATT_SS16</sub>	Average battery current, 6 outputs @ 16 V steady state	-	1,190	1,560		At VHV = 20 V AVDD = 3.3 V
I <sub>L_BOOST</sub>	Average inductor current, 3 outputs actively switching 16 V for 1205 μs to 2 V for 1705 μs to 8 V for 1705 μs and 3 outputs are @ 16 V steady state	-	1,480	2,050		At VHV = 20 V AVDD = 3.3 V
I <sub>L_BOOST_SS0</sub>	Average inductor current, 6 outputs @ 0 V steady state	-	500	790		At VHV = 20 V AVDD = 3.3 V
I <sub>L_BOOST_SS2</sub>	Average inductor current, 6 outputs @ 2 V steady state	-	560	850		At VHV = 20 V AVDD = 3.3 V
I <sub>L_BOOST_SS16</sub>	Average inductor current, 6 outputs @ 16 V steady state	-	930	1,270		At VHV = 20 V AVDD = 3.3 V
I <sub>VIO_INACT</sub>	VIO average inactive current	-	-	3		VIO is high, no bus activity
I <sub>VIO_ACTIVE</sub>	VIO average active current	-	-	250		VIO = 1.8 V, master sending data at 26 MHz
V <sub>VREG</sub>		2.05	-	2.3	V	No external load allowed

**LOW POWER MODE**

I <sub>AVDD</sub>	AVDD Supply Current	-	-	8	μA	
I <sub>L_BOOST</sub>	L_BOOST Leakage	-	-	6		
I <sub>BATT</sub>	Battery Current	-	-	14		I <sub>AVDD</sub> + I <sub>L_BOOST</sub>
I <sub>VIO</sub>	VIO Supply Current	-	-	3		No bus activity
V <sub>VREG</sub>		2.0	-	3.3	V	No external load allowed

# TCC-106

**Table 5. BOOST CONVERTER CHARACTERISTICS**

(AVDD from 2.3 V to 5.5 V; VIO from 1.1 V to 3.0 V;  $T_A = -30$  to  $+85^\circ\text{C}$ ;  $C_{HV} = 22$  nF;  $L_{BOOST} = 15$   $\mu\text{H}$ ; unless otherwise specified)

Symbol	Parameter	Conditions	Min	Typ	Max	Unit
VHV_min	Minimum programmable output voltage (average), DAC Boost = 0h	Active mode	–	9	–	V
VHV_max	Maximum programmable output voltage (average), DAC Boost = Fh	Active mode	–	24	–	
Resolution	Boost voltage resolution	4-bit DAC	–	1	–	
$I_{L\_BOOST\_LIMIT}$	Inductor current limit		–	200	–	mA

**Table 6. ANALOG OUTPUTS (OUT A, OUT B, OUT C)**

(AVDD from 2.3 V to 5.5 V; VIO from 1.1 V to 3.0 V; VHV = 24 V;  $T_A = -30$  to  $+85^\circ\text{C}$ ;  $R_{load} = \infty$  unless otherwise specified)

Parameter	Description	Min	Typ	Max	Unit	Comment
-----------	-------------	-----	-----	-----	------	---------

## SHUTDOWN MODE

$Z_{OUT}$	OUT A, OUT B, OUT C, OUT D, OUT E, OUT F output impedance	7	–	–	megaohm	DAC disabled
-----------	---	---	---	---	---------	--------------

## ACTIVE MODE

$V_{OH}$	Maximum output voltage	22.0	–	–	V	DAC A, B, C, D, E or F = 7Fh, DAC Boost = Fh, $I_{OH} < 10$ $\mu\text{A}$
$V_{OL}$	Minimum output voltage	–	–	1	V	DAC A, B, C, D, E or F = 01h, DAC Boost = 0h to Fh, $I_{OH} < 10$ $\mu\text{A}$
Slew Rate		–	6.5	10	$\mu\text{s}$	2 V to 20 V step, measured at $V_{OUT} = 15.2$ V, $R_{LOAD} =$ equivalent series load of 2.7 kohm and 5.6 nF, Turbo enabled
$R_{PD}$	OUT A, OUT B, OUT C, OUT D, OUT E, OUT F set in pull-down mode	–	–	800	ohm	DAC A, B, C, D, E or F = 00h, DAC Boost = 0h to Fh, selected output(s) is disabled
Resolution	Voltage resolution (1-bit)	–	188	–	mV	(1 LSB = 1-bit)
$V_{OFFSET}$	Zero scale, least squared best fit	–1	–	+1	LSB	
Error		–3.0	–	+3.0	% $V_{OUT}$	Over 2 V – 20 V $V_O$ range
DNL	Differential non-linearity least squared best fit	–0.9	–	+0.9	LSB	Over 2 V – 20 V $V_O$ range
INL	Integral non-linearity least squared best fit	–1	–	+1	LSB	Over 2 V – 20 V $V_O$ range
$I_{SC}$	Over current protection	–	35	65	mA	Any DAC output shorted to ground
$V_{RIPPLE}$	Output ripple with all outputs at steady state	–	–	40	mV RMS	Over 2 V – 20 V for VHV = 23.5 V

## Theory of Operation

## Overview

The control IC outputs are directly controlled by programming the six DACs (DAC A, DAC B, DAC C, DAC D, DAC E and DAC F) through the digital interface.

The DAC stages are driven from a reference voltage, generating an analog output voltage driving a high-voltage amplifier supplied from the boost converter (see Figure 1 – Control IC Functional Block Diagram).

The control IC output voltages are scaled from 0 V to 24 V, with 128 steps of 188 mV ( $2\text{ V} \times 24\text{ V} / 255\text{ V} = 0.188235\text{ V}$ ). The nominal control IC output can be approximated to  $188\text{ mV} \times (\text{DAC value})$ .

For performance optimization the boost output voltage (VHV) can be programmed to levels between 9 V and 24 V via the DAC\_boost register (4 bits with 1 V steps). The startup default level for the boosted voltage is  $\text{VHV} = 24\text{ V}$ .

For proper operation and to avoid saturation of the output devices and noise issues it is recommended to operate the boosted VHV voltage at least 2 V above the highest programmed  $V_{\text{OUT}}$  voltage of any of the six outputs.

When the DAC output value is set to 00h the corresponding output is disabled and the output is pulled to GND through an effective impedance of less than 800 ohms.

## Operating Modes

The following operating modes are available:

1. **Shutdown Mode:** All circuit blocks are off, the DAC outputs are disabled and placed in high Z state and current consumption is limited to minimal leakage current. The shutdown mode is entered upon initial application of AVDD or upon VIO being placed in the low state. The contents of the registers are not maintained in shutdown mode.

2. **Startup Mode:** Startup is only a transitory mode. Startup mode is entered upon a VIO high state. In startup mode all registers are reset to their default states, the digital interface is functional, the boost converter is activated, outputs OUT A, OUT B, OUT C, OUT D, OUT E and OUT F are disabled and the DAC outputs are placed in a high Z state. Control software can request a full hardware and register reset of the TCC-106 by sending an appropriate PWR\_MODE command to direct the chip from either the active mode or the low power mode to the startup mode. From the startup mode the device automatically proceeds to the active mode.
3. **Active Mode:** All blocks of the TCC-106 are activated and the DAC outputs are fully controlled through the digital interface, DACs remain off until enabled. The DAC settings can be dynamically modified and the HV outputs will be adjusted according to the specified timing diagrams. Each DAC can be individually controlled and/or switched off according to application requirements. Active mode is automatically entered from the startup mode. Active mode can also be entered from the low power mode under control software command.
4. **Low Power Mode:** In low power mode the serial interface stays enabled, the DAC outputs are disabled and are placed in a high Z state and the boost voltage circuit is disabled. Control software can request to enter the low power mode from the active mode by sending an appropriate PWR\_MODE command. The contents of all registers are maintained in the low power mode.

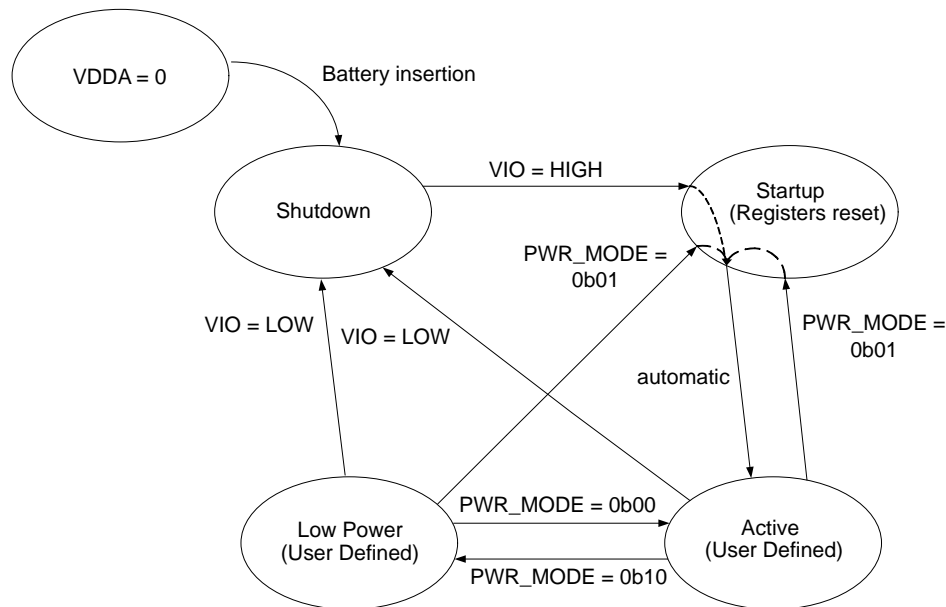

Figure 2. Modes of Operation

**AVDD Power-On Reset (POR)**

Upon application of AVDD the TCC-106 will be in shutdown mode. All circuit blocks are off and the chip draws only minimal leakage current.

**VIO Power-On Reset and Startup Conditions**

A high level on VIO places the chip in startup mode which provides a POR to the TCC-106. POR resets all registers to their default settings as described in Table 8. VIO POR also resets the serial interface circuitry. POR is not a brown-out detector and VIO needs to be brought back to a low level to enable the POR to trigger again.

**Table 7. VIO POWER-ON RESET AND STARTUP**

Register	Default State for VIO POR	Comment
DAC Boost	[1111]	VHV = 24 V
Power Mode	[01]>[00]	Transitions from shutdown to startup and then automatically to active mode
DAC Enable	[000000]	V <sub>OUT</sub> A, B, C, D, E and F Disabled
DAC A		Output in High-Z Mode
DAC B		Output in High-Z Mode
DAC C		Output in High-Z Mode
DAC D		Output in High-Z Mode
DAC E		Output in High-Z Mode
DAC F		Output in High-Z Mode

**VIO Shutdown**

A low level at any time on VIO places the chip in shutdown mode in which all circuit blocks are off. The contents of the registers are not maintained in shutdown mode.

**Table 8. VIO THRESHOLDS** (AVDD from 2.3 V to 5.5 V; T<sub>A</sub> = -30 to +85°C unless otherwise specified)

Parameter	Description	Min	Typ	Max	Unit	Comments
VIORST	VIO Low Threshold	-	-	0.2	V	When VIO is lowered below this threshold level the chip is reset and placed into the shutdown state

**Power Supply Sequencing**

The AVDD input is typically directly supplied from the battery and thus is the first on. After AVDD is applied and before VIO is applied to the chip, all circuits are in the shutdown state and draw minimum leakage currents. Upon application of VIO, the chip automatically starts up using default settings and is placed in the active state waiting for a command via the serial interface.

**Table 9. TIMING** (AVDD from 2.3 V to 5.5 V; VIO from 1.1 V to 3.0 V; T<sub>A</sub> = -30 to +85°C; OUT A, OUT B, OUT C, OUT D, OUT E & OUT F; CHV = 22 nF; L<sub>BOOST</sub> = 15 μH; VHV = 20 V; Turbo-Charge mode off unless otherwise specified)

Parameter	Description	Min	Typ	Max	Unit	Comments
T <sub>POR_VREG</sub>	Internal bias settling time from shutdown to active mode	-	50	120	μs	For info only
T <sub>BOOST_START</sub>	Time to charge CHV @ 95% of set VHV	-	130	-	μs	For info only
T <sub>SD_TO_ACT</sub>	Startup time from shutdown to active mode	-	180	300	μs	
T <sub>SET+</sub>	Output A, B, C, D, E, F positive settling time to within 5% of the delta voltage, equivalent series load of 2.7 kohm and 5.6 nF, V <sub>OUT</sub> from 2 V to 20 V; 0Bh (11d) to 55h (85d)	-	50	60	μs	Voltage settling time connected on V <sub>OUT</sub> A, B, C, D, E, F
T <sub>SET-</sub>	Output A, B, C, D, E, F negative settling time to within 5% of the delta voltage, equivalent series load of 2.7 kohm and 5.6 nF, V <sub>OUT</sub> from 20 V to 2 V; 55h (85d) to 0Bh (11d)	-	50	60	μs	Voltage settling time connected on V <sub>OUT</sub> A, B, C, D, E, F
T <sub>SET+</sub>	Output A, B, C, D, E, F positive settling time with Turbo	-	35	-	μs	Voltage settling time connected on V <sub>OUT</sub> A, B, C, D, E, F
T <sub>SET-</sub>	Output A, B, C, D, E, F negative settling time with Turbo	-	35	-	μs	Voltage settling time connected on V <sub>OUT</sub> A, B, C, D, E, F

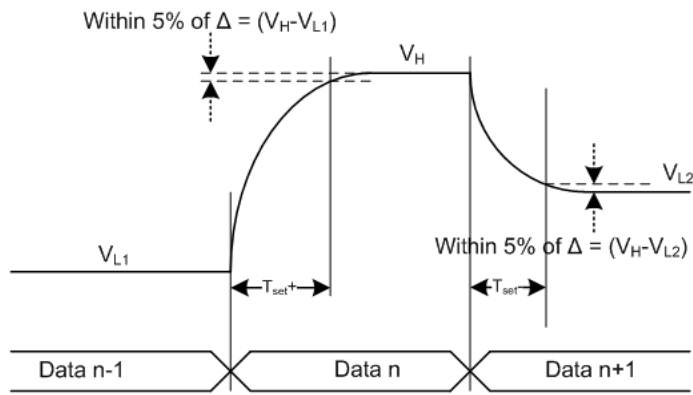

Figure 3. Output Settling Diagram

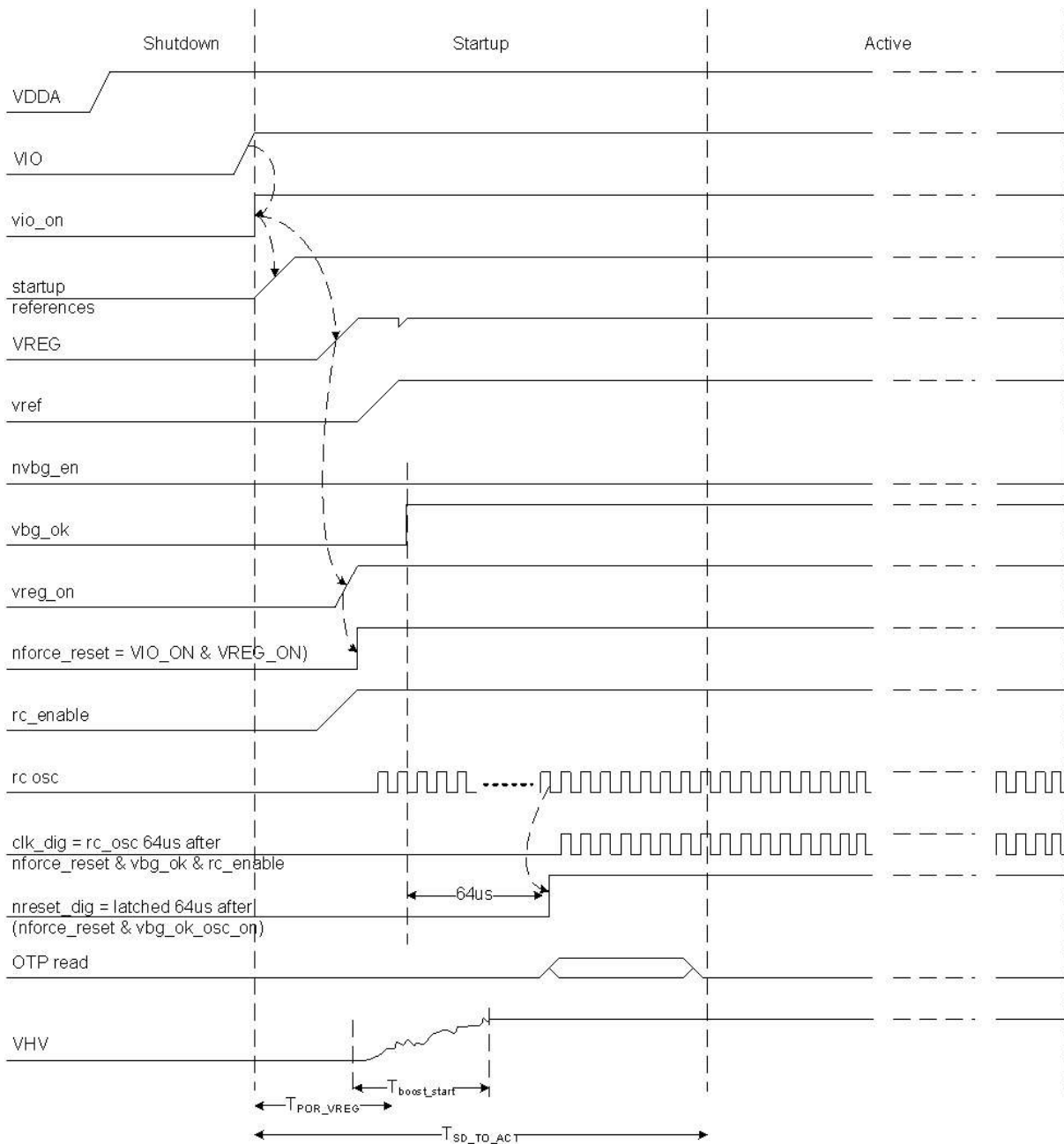

Figure 4. Startup Timing Diagram



**Boost Control**

The TCC-106 integrates an asynchronous current control boost converter. It operates in a discontinuous mode and features spread-spectrum circuitry for Electro-Magnetic Interference (EMI) reduction. The average boost clock is 2 MHz and the clock is spread between 0.8 MHz and 3.2 MHz.

**Boost Output Voltage (VHV) Control Principle**

The asynchronous control starts the boost converter as soon as the VHV voltage drops below the reference set by the 4-bit DAC and stops the boost converter when the VHV voltage rises above the reference again.

Due to the slow response time of the control loop, the VHV voltage may drop below the set voltage before the control loop compensates for it. In the same manner, VHV can rise higher than the set value. This effect may reduce the maximum output voltage available. Please refer to Figure 6 below.

The asynchronous control reduces switching losses and improves the output (VHV) regulation of the DC/DC converter under light load, particularly in the situation where the TCC-106 only maintains the output voltages to fixed values.

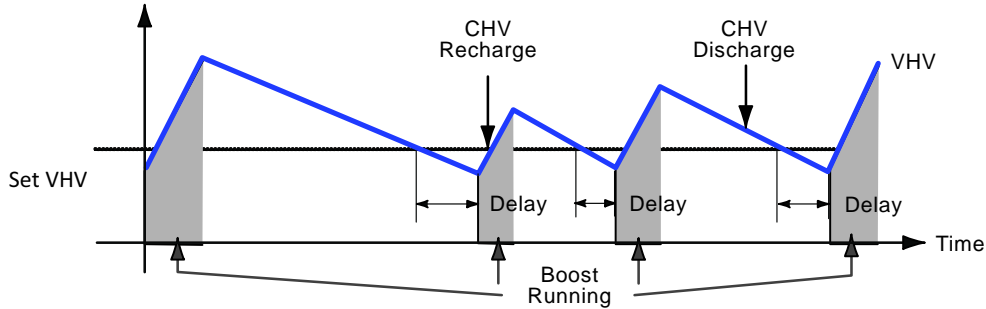

Figure 5. VHV Voltage Waveform

**High Impedance (High Z) Feature**

In shutdown mode the OUT pins are set to a high impedance mode (high Z). Following is the principle of operation for the control IC:

1. The DAC output voltage  $V_{OUT}$  is defined by:

$$V_{OUT} = \frac{\text{DAC code}}{255} \times 24 \text{ V} \times 2 \quad (\text{eq. 1})$$

2. The voltage VHV defines the maximum supply voltage of the DAC supply output regulator and is set by a 4-bit control.
3. The maximum DAC DC output voltage  $V_{OUT}$  is limited to  $(VHV - 2 \text{ V})$ .
4. The minimum output DAC voltage  $V_{OUT}$  is 1.0 V max.

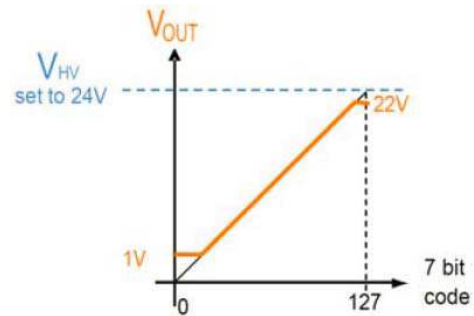

Figure 7. DAC Output Range Example B

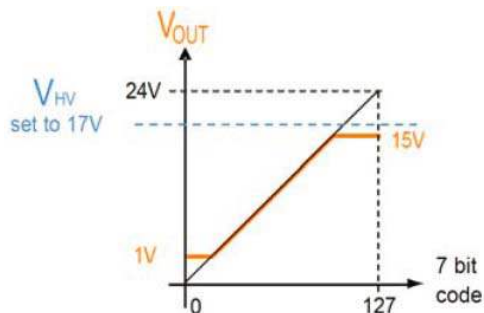

Figure 6. DAC Output Range Example A

**Digital Interface**

The control IC is fully controlled through a digital interface (DATA, CLK, CS). The digital interface automatically detects and responds to MIPI RFFE interface commands, 3-wire 30-bit serial interface commands or 3-wire 32-bit serial interface commands. Auto-detection is accomplished on a frame by frame basis. The digital interface is described in the following sections of this document, for detailed programming instructions please refer to the programming guide, available by contacting ON Semiconductor.

**3-Wire Serial Interface**

The 3-wire serial interface operates in a synchronous write-only 3-wire slave mode. 30-bit or 32-bit message length is automatically detected for each frame. If CS changes state before all bits are received then all data bits are ignored. Data is transmitted most significant bit first and DATA is latched on the rising edge of CLK. Commands are latched on the falling edge of CS.

## TCC-106

**Table 10. 3-WIRE SERIAL INTERFACE SPECIFICATION**

( $T_A = -30$  to  $+85^\circ\text{C}$ ;  $2.3\text{ V} < \text{AVDD} < 5.5\text{ V}$ ;  $1.1\text{ V} < \text{VIO} < 3.0\text{ V}$ ; unless otherwise specified)

Parameter	Description	Min	Typ	Max	Unit	Comments
$F_{\text{CLK}}$	Clock Frequency	–	–	26	MHz	
$T_{\text{CLK}}$	Clock Period	38.4	–	–	ns	
NBIT	Bits Number	–	30/32	–	bits	Auto-detection 30-bit or 32-bit
$T_{\text{HIGH}}$	Clock High Time	13	–	–	ns	
$T_{\text{LOW}}$	Clock Low Time	13	–	–	ns	
$T_{\text{CSSETUP}}$	CS Set-up Time	5	–	–	ns	70% rising edge of CS to 30% rising edge of first clock cycle
$T_{\text{CSHOLD}}$	CS Hold Time	5	–	–	ns	30% falling edge of last clock cycle to 70% falling edge of CS
$T_{\text{DSETUP}}$	Data Set-up Time	4	–	–	ns	Relative to 30% of CLK rising edge
$T_{\text{D HOLD}}$	Data Hold Time	4	–	–	ns	relative to 70% of CLK rising edge
$T_{\text{SUCC}}$	CS Low Time Between Successive Writes	38.4	–	–	ns	70% falling edge of CS to 70% rising edge of CS
$T_{\text{SUCC}}$	CS Low Time Between Successive DAC Update Writes	1,500	–	–	ns	Time between groups of DAC update reg [00000] & [00001] writes
$C_{\text{CLK}}$	Input Capacitance	–	–	5	pF	CLK pin
$C_{\text{DATA}}$	Input Capacitance	–	–	8.3	pF	DATA pin
$C_{\text{CS}}$	Input Capacitance	–	–	5	pF	CS pin
$C_{\text{TRIG}}$	Input Capacitance	–	–	10	pF	TRIG pin
$V_{\text{IH}}$	Input Logic Level High	$0.7 \times \text{VIO}$	–	$\text{VIO} + 0.3$	V	DATA, CLK, CS
$V_{\text{IL}}$	Input Logic Level Low	–0.3	–	$0.3 \times \text{VIO}$	V	DATA, CLK, CS
$I_{\text{IH\_DATA}}$	Input Current High	–2	–	10	$\mu\text{A}$	DATA
$I_{\text{IL\_DATA}}$	Input Current Low	–2	–	1	$\mu\text{A}$	DATA
$I_{\text{IH\_CLK,CS}}$	Input Current High	–1	–	10	$\mu\text{A}$	CLK, CS
$I_{\text{IL\_CLK,CS}}$	Input Current Low	–1	–	1	$\mu\text{A}$	CLK, CS
$V_{\text{TP\_TRIG}}$	Positive Going Threshold Voltage	$0.4 \times \text{VIO}$	–	$0.7 \times \text{VIO}$	V	TRIG
$V_{\text{TN\_TRIG}}$	Negative Going Threshold Voltage	$0.3 \times \text{VIO}$	–	$0.6 \times \text{VIO}$	V	TRIG
$V_{\text{H\_TRIG}}$	Hysteresis Voltage ( $V_{\text{TP}} - V_{\text{TN}}$ )	$0.1 \times \text{VIO}$	–	$0.4 \times \text{VIO}$	V	TRIG
$I_{\text{IH\_TRIG}}$	TRIG Input Current High	–2	–	10	$\mu\text{A}$	TRIG=0.8 x VIO
$I_{\text{IL\_TRIG}}$	TRIG Input Current Low	–2	–	1	$\mu\text{A}$	TRIG=0.2 x VIO

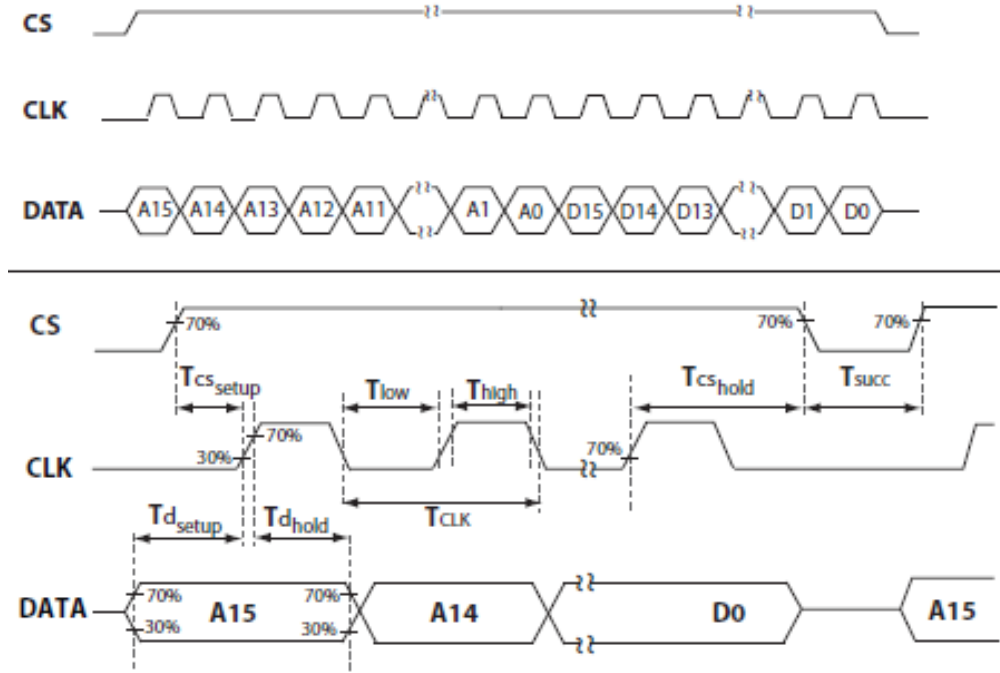

Figure 8. 3-wire Serial Interface Signal Timing

**SPI Frame Length Decoding**

30-bit or 32-bit frame length is automatically detected. The length of the frame is defined by the number of clock

rising edges while CS is kept high. The TCC-106 will not respond to a SPI command if the length of the frame is not exactly 30 bits or 32 bits. SPI registers are write only.

**SPI Frame Structure**

Table 11. 32 BITS FRAME: ADDRESS DECODING (1, 2, 3, 4, 5 or 6 OUTPUTS)

H0	H1	R/W	A12	A11	A10	A9	A8	A7	A6	A5	A4	A3	A2	A1	A0
1	1	0	1	0	1	0	0	1	0	0	X	X	X	X	X
ON Semiconductor Header		R/W	Device ID			Specific Device ID				Register Address for Operation					

Table 12. 30 BITS FRAME: ADDRESS DECODING (1, 2, 3, 4, 5 or 6 OUTPUTS)

R/W	A12	A11	A10	A9	A8	A7	A6	A5	A4	A3	A2	A1	A0
0	1	0	1	0	0	1	0	0	X	X	X	X	X
R/W	Device ID			Specific Device ID				Register Address for Operation					

Table 13. 3-WIRE SERIAL INTERFACE ADDRESS MAP

A4	A3	A2	A1	A0	Data[15:8]	Data[7:0]
0	0	0	0	0	Turbo-Charge Settings for DAC A, B, C	DAC C
0	0	0	0	1	DAC B	DAC A
0	0	0	1	0	Turbo-Charge Settings for DAC D, E, F	DAC F
0	0	0	1	1	DAC E	DAC D
0	0	1	0	0	Turbo-Charge Delay Parameters for DAC A, B, C	Turbo Threshold Delay Settings for A, B, C
0	0	1	0	1	Turbo-Charge Delay Parameters for DAC D, E, F	Turbo Threshold Delay Settings for A, B, C
1	0	0	0	0	Mode Select + Control IC Setup	

Table 13. 3-WIRE SERIAL INTERFACE ADDRESS MAP

1	0	0	1	0	Reserved	Reserved
to						
1	1	1	1	1		

**Turbo-Charge Mode**

The TCC-106 control IC has a Turbo-Charge mode that significantly shortens the system settling time when changing programming voltages. In Turbo-Charge mode the DAC output target voltage is temporarily set to either a delta voltage above or a delta voltage below the actual desired target for the TCDLY time. It is recommended that V<sub>HV</sub> be set to 24 V when using Turbo-Charge mode.

**Glide Mode**

Unlike turbo mode, which is intended to reduce the charging time, the glide mode extends the transition time of each DAC output. Each DAC has an individual control for turbo mode, glide mode or regular voltage switching. The glide mode can be enabled for a particular DAC through the INDEX register, by setting DAC State to '1' when glide mode is enabled, turbo mode is off for a particular DAC, but one DAC can be gliding while the other is turbo.

During glide mode the output voltage of a DAC is either increased or decreased to its set end point, in max 255 steps, where each DAC time step can be programmed between 2 μs to 64 μs. For programming the glide mode refer to the application note (coming soon). A programming input is not required to maintain a glide transition, all step controls are maintained by the part. Only the inputs to define the glide need to be programmed.

**RF Front-End Control Interface (MIPI RFFE Interface)**

The TCC-106 is a read/write slave device which is fully compliant to the MIPI Alliance Specification for RF Front-End Control Interface (RFFE) Version 1.10.00 26 July 2011. This device is rated at full-speed operation for 1.65 V < V<sub>IO</sub> < 1.95 V and at half-speed operation for 1.1 V < V<sub>IO</sub> < 1.65 V. When using the MIPI RFFE interface the CS pin must be grounded externally.

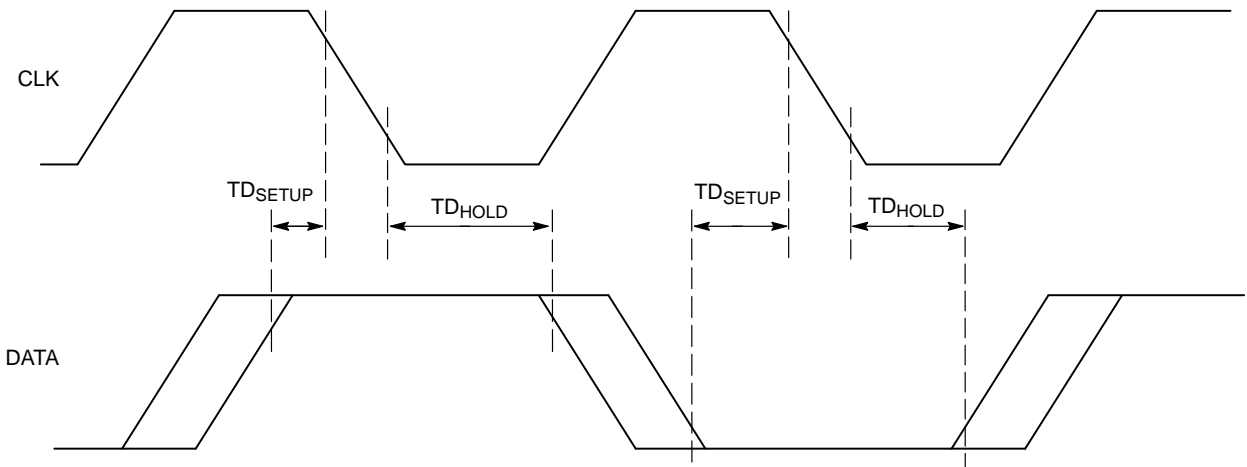

Figure 9. MIPI-RFFE Signal Timing during Master Writes to PTIC Control IC

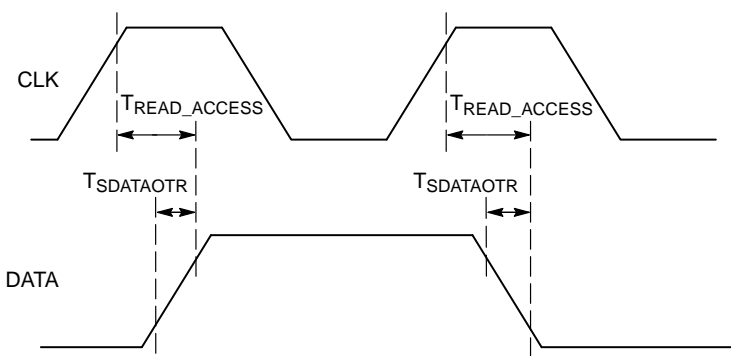

Figure 10. MIPI-RFFE Signal Timing during Master Reads from PTIC Control IC

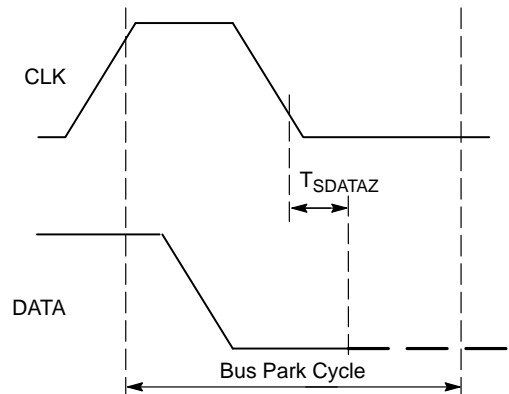

Figure 11. Bus Park Cycle Timing when MIPI-RFFE Master Reads from PTIC Control IC

**Table 14. MIPI RFFE INTERFACE SPECIFICATION**(T<sub>A</sub> = -30 to +85°C; 2.3 V < AVDD < 5.5 V; 1.1 V < VIO < 1.95 V; unless otherwise specified)

Parameter	Description	Min	Typ	Max	Unit	Comments
F <sub>SCLK</sub>	Clock Full-Speed Frequency	0.032	-	26	MHz	Full-Speed Operation: 1.65 V < VIO < 1.95 V
T <sub>SCLK</sub>	Clock Full-Speed Period	0.038	-	32	μs	Full-Speed Operation: 1.65 V < VIO < 1.95 V
T <sub>SCLKIH</sub>	CLK Input High Time	11.25	-	-	ns	Full-Speed
T <sub>SCLKIL</sub>	CLK Input Low Time	11.25	-	-	ns	Full-Speed
F <sub>SCLK_HALF</sub>	Clock Half-Speed Frequency	0.032	-	13	MHz	
T <sub>SCLK_HALF</sub>	Clock Half-Speed Period	0.038	-	64	μs	
T <sub>SCLKIH</sub>	CLK Input High Time	24	-	-	ns	Half-Speed
T <sub>SCLKIL</sub>	CLK Input Low Time	24	-	-	ns	Half-Speed
V <sub>TP</sub>	Positive Going Threshold Voltage	0.4 x VIO	-	0.7 x VIO	V	CLK, DATA, TRIG, 1.2 or 1.8 V Bus
V <sub>TN</sub>	Negative Going Threshold Voltage	0.3 x VIO	-	0.6 x VIO	V	CLK, DATA, TRIG, 1.2 or 1.8 V Bus
V <sub>H</sub>	Hysteresis Voltage (V <sub>TP</sub> - V <sub>TN</sub> )	0.1 x VIO	-	0.4 x VIO	V	CLK, DATA, TRIG, 1.2 or 1.8 V Bus
I <sub>IH</sub>	Input Current High	-2	-	+10	μA	TRIG, SDATA = 0.8 x VIO
		-1	-	+10	μA	SCLK = 0.8 x VIO
I <sub>IL</sub>	Input Current Low	-2	-	+1	μA	TRIG, SDATA = 0.2 x VIO
		-1	-	+1	μA	SCLK = 0.2 x VIO
C <sub>CLK</sub>	Input Capacitance	-	-	5	pF	CLK Pin
C <sub>DATA</sub>	Input Capacitance	-	-	8.3	pF	DATA Pin
C <sub>TRIG</sub>	Input Capacitance	-	-	10	pF	TRIG Pin
TD <sub>SETUP</sub>	Write DATA Setup Time	1	-	-	ns	Full-Speed
TD <sub>HOLD</sub>	Write DATA Hold Time	5	-	-	ns	Full-Speed
TD <sub>SETUP</sub>	Write DATA Setup Time	2	-	-	ns	Half-Speed
TD <sub>HOLD</sub>	Write DATA Hold Time	5	-	-	ns	Half-Speed
T <sub>SUCC</sub>	Time Between Successive DAC Update Writes	1,500	-	-	ns	
T <sub>READ_ACCESS</sub>	Read DATA valid from CLK rising edge	-	-	100	ns	Full or Half Speed at VIO = 1.10 V, and max 15 pF load on DATA pin
T <sub>SDATAOTR</sub>	Read DATA output transition	-	-	65	ns	Full or Half Speed at VIO = 1.10 V, and max 15 pF load on DATA pin
T <sub>SDATAZ</sub>	Read DATA drive release time	-	-	180	ns	Full or Half Speed at VIO = 1.10 V, and max 15 pF load on DATA pin
T <sub>READ_ACCESS</sub>	Read DATA valid from CLK rising edge	-	-	31	ns	Full or Half Speed at VIO = 1.80 V, and max 15 pF load on DATA pin
T <sub>SDATAOTR</sub>	Read DATA output transition	-	-	14	ns	Full or Half Speed at VIO = 1.80 V, and max 15 pF load on DATA pin
T <sub>SDATAZ</sub>	Read DATA drive release time	-	-	50	ns	Full or Half Speed at VIO = 1.80 V, and max 15 pF load on DATA pin

## TCC-106

The control IC contains twenty-four 8-bit registers. Register content is described in Table 15. Some additional registers implemented as provision, are not described in this document.

**Table 15. MIPI RFFE ADDRESS MAP**

Register Address	Description	Purpose	Access Type	Size (bits)
0x00	DAC Configuration (Enable Mask)	High voltage output enable mask	Write	7
0x01	Turbo Register DAC A, B & C	Turbo-charge configuration DAC A, B & C	Write	8
0x02	DAC A Register	OUT A value [6:0], Turbo Index [7]**	Write	8
0x03	DAC B Register	OUT B value [6:0], Turbo Index [7]**	Write	8
0x04	DAC C Register	OUT C value [6:0], Turbo Index [7]**	Write	8
0x05	Turbo Register DAC D, E & F	Turbo-charge configuration DAC D,E & F	Write	8
0x06	DAC D Register	OUT D value [6:0], Turbo Index [7]**	Write	8
0x07	DAC E Register	OUT E value [6:0], Turbo Index [7]**	Write	8
0x08	DAC F Register	OUT F value [6:0], Turbo Index [7]**	Write	8
0x10	DAC Boost (VHV)	Settings for the boost high voltage	Write	8
0x11	Trigger register	Trigger configuration	Write	8
0x12	Turbo-Charge Delay DAC A, B, C	Turbo-charge delay steps DAC A, B, C	Write	8
0x13	Turbo-Charge Delay DAC A, B, C	Turbo-charge delay, multiplication DAC A, B, C	Write	8
0x14	Turbo-Charge Delay DAC D, E, F	Turbo-charge delay steps DAC D, E, F	Write	8
0x15	Turbo-Charge Delay DAC D, E, F	Turbo-charge delay multiplication DAC D, E, F	Write	8
0x1C	Power Mode and Trigger Register	Power mode & trigger control PWR_MODE [7:6] TRIG_REG [5:0]	Write	8
0x1D	Product ID Register	Product number * Hard coded into ASIC	Write	8
0x1E	Manufacturer ID Register	MN (10 bits long) Manufacturer ID[7:0] Hard Coded into ASIC	Write	8
0x1F	Unique Slave Identifier Register (USID)	Spare [7:6] [5,4] = Manufacturer ID [9:8] USID [3:0]	Write	8

\*The second least significant bit can be programmed in OTP during manufacture

\*\* The details for configuration of Turbo mode should be ascertained from the Programming Guide, available from ON Semiconductor

### Configuration Settings

**Table 16. DAC CONFIGURATION (ENABLE MASK) at [0x00] Defaults shown as (x)**

Bit 6 (1)	Bit 5 (0)	Bit 4 (0)	Bit 3 (0)	Bit 2 (0)	Bit 1 (0)	Bit 0 (0)
SSE	DAC E	DAC F	DAC A	DAC B	DAC C	DAC D

SSE = 0 spread spectrum disabled, SSE = 1 spread spectrum enabled (default), this controls the average boost clock which is nominally 2 MHz and spread between 0.8 MHz and 3.2 MHz when enabled (default). The hardware does not limit driving more than three DACs at the same time, however it is recommended to have max three DACs changing outputs at one time, no restrictions exist as to which three.

Table 17. DAC MODE SETUP: DAC ENABLE

Bit3	Bit2	Bit1	DAC A	DAC B	DAC C	
0	0	0	Off	Off	Off	(Default)
0	0	1	Off	Off	Enabled	
0	1	0	Off	Enabled	Off	
0	1	1	Off	Enabled	Enabled	
1	0	0	Enabled	Off	Off	
1	0	1	Enabled	Off	Enabled	
1	1	0	Enabled	Enabled	Off	
1	1	1	Enabled	Enabled	Enabled	

Table 18. DAC MODE SETUP: DAC ENABLE

Bit5	Bit4	Bit0	DAC E	DAC F	DAC D	
0	0	0	Off	Off	Off	(Default)
0	0	1	Off	Off	Enabled	
0	1	0	Off	Enabled	Off	
0	1	1	Off	Enabled	Enabled	
1	0	0	Enabled	Off	Off	
1	0	1	Enabled	Off	Enabled	
1	1	0	Enabled	Enabled	Off	
1	1	1	Enabled	Enabled	Enabled	

Table 19. BOOST DAC MODE SETUP (VHV) at [0x10] (Note 5)

Bit 7*	Bit 6*	Bit 5*	Bit 4	Bit 3	Bit 2	Bit 1	Bit 0	VHV (V)
0	0	0	1	0	0	0	0	9
0	0	0	1	0	0	0	1	10
0	0	0	1	0	0	1	0	11
0	0	0	1	0	0	1	1	12
0	0	0	1	0	1	0	0	13
0	0	0	1	0	1	0	1	14
0	0	0	1	0	1	1	0	15
0	0	0	1	0	1	1	1	16
0	0	0	1	1	0	0	0	17
0	0	0	1	1	0	0	1	18
0	0	0	1	1	0	1	0	19
0	0	0	1	1	0	1	1	20
0	0	0	1	1	1	0	0	21
0	0	0	1	1	1	0	1	22
0	0	0	1	1	1	1	0	23
0	0	0	1	1	1	1	1	24 (Default)

5. Bit 4 is fixed at logic 1 for reverse software compatibility

\*Indicates reserved bits

### MIPI RFFE TRIG Operation

The MIPI RFFE Trigger mode can be used as a synchronization signal to ensure that new DAC settings are applied to the outputs at appropriate times in the overall transceiver system. When the MIPI RFFE TRIG function is enabled via [0x11] bit 4 the requested DAC voltage levels are set up in the shadow registers and not transferred to the destination registers until the trigger condition is met. In this manner the change in output voltage levels are synchronized with the MIPI RFFE TRIG command. If multiple DAC voltage level requests are received before the TRIG event occurs, only the last fully received DAC output voltage level will be applied to the outputs.

The trigger configuration also provides for an additional external TRIG pin to be used as a synchronization signal. The external TRIG is independent from the built-in triggers available within the MIPI RFFE interface. When the TRIG input pin is enabled via [0x11] bit 4 the requested DAC voltage levels are set up in the shadow registers and are not transferred to the destination registers until the external trigger condition is met. In this manner the change in output voltage levels are synchronized with the external TRIG event. The external TRIG input is referenced to VIO. To

improve interfacing options the polarity of external TRIG is programmable via [0x11] bit 1.

If the external trigger function is not needed in the application, the TRIG pin should be grounded and the TRIG function disabled. When TRIG pin is disabled by register [0x11] 'TRIG Select' = '1' (default) and register [0x10] 'Trigger Mask 0, 1, 2' = '1':

- The requested DAC voltage levels for DAC A, B, C are applied to the outputs all together at the same time, after DAC C value is written. This event will not affect the outputs of DAC D, E, F.
- The requested DAC voltage levels for DAC D, E, F are applied to the outputs all together at the same time, after DAC F value is written. This event will not affect the outputs of DAC A, B, C.
- Optionally a configuration register can select the last DAC to be written in order to trigger internally the update of all six DACs at the same time. For example the configuration register can select that a write to DAC B value will trigger internally the update of all six DACs outputs.

**Table 20. TRIGGER CONFIGURATION at [0x11]**

Bit 7	Bit 6	Bit 5	Bit 4	Bit 3	Bit 2	Bit 1	Bit 0
Res* 0	Res* 0	Res* 0	TRIG Select 0 = Ext TRIG Pin 1 = RFFE Trigger	Reserved 0		TRIG Edge 0 = Active Falling 1 = Active Rising	Mask Ext TRIG 1 = Mask Trig Pin

\*Reserved bits

**Table 21. EXTERNAL TRIGGER CONFIGURATION BIT SETTING AT [0x11]**

Bit 4	Bit 3	Bit 2	Bit 1	Bit 0	Description
0	-	-	X	0	External trigger pin is enabled. Sending the RFFE message will load a 'shadow' register only. Only upon an active signal on external TRIG pin are the output registers loaded with the new voltage settings which are then applied to the outputs.
1	-	-	X	X	The MIPI RFFE trigger is enabled (Default)
0	-	-	0	0	External TRIG pin signal is active falling
0	-	-	1	0	External TRIG pin signal is active rising (Default)
X	-	-	X	0	External trigger pin is not masked
X	-	-	X	1	Mask external trigger pin (Default)

**Table 22. POWER MODE AND TRIGGER REGISTER [0x1C]**

Bit 7	Bit 6	Bit 5	Bit 4	Bit 3	Bit 2	Bit 1	Bit 0
PM1	PM0	Trigger Mask 2	Trigger Mask 1	Trigger Mask 0	Trigger 2	Trigger 1	Trigger 0

Writing a logic one ('1') to the bits 0, 1 or 2 (Trigger 0, 1 or 2) moves data from the shadow registers into the destination registers. Default for bit 0, 1 and 2 is logic low.

If trigger mask bit 0, 1 or 2 is set ('1') the trigger 0, 1 or 2 are disabled respectively and the data goes directly to the destination register. Default for bit 3, 4 and 5 is logic low.

All three triggers behave in the same way as the external pin TRIG. When each of these triggers is set using the MIPI RFFE interface the results are the same as when an active edge is applied to the TRIG pin when external pin TRIG is selected



Table 23. POWER MODE BIT SETTING IN REGISTER [0x1C]

PM1	PM0	State	Description
0	0	Active	Boost Control Active, VHV set by Digital Interface V <sub>OUT</sub> A, B, C, D, E, F Enabled and Controlled by Digital Interface (Default)
0	1	Startup	Boost Control Active, VHV set by Digital Interface V <sub>OUT</sub> A, B, C, D, E, F Disabled
1	0	Low Power	Digital Interface is Active While All Other Circuits are in Low Power Mode
1	1	Reserved	State of Hardware Does Not Change

**Command Sequences**

- **Register 0 Write** (used to access the Register 0 DAC Configuration – Enable Mask). Register 0 can be also be accessed using Register Write or/and Extended Register Write.
- **Register Write** (used to access only one register at the time)
- **Extended Register Write** (used to access a group of contiguous registers with one command)

**Register 0 Write Command Sequence**

The Command Sequence starts with a Sequence Start Condition (SSC) which is followed by the Register 0 Write Command Frame. This Frame contains the Slave address, a logic one, and the seven bit word that will be written to Register 0. The Command Sequence is depicted below.

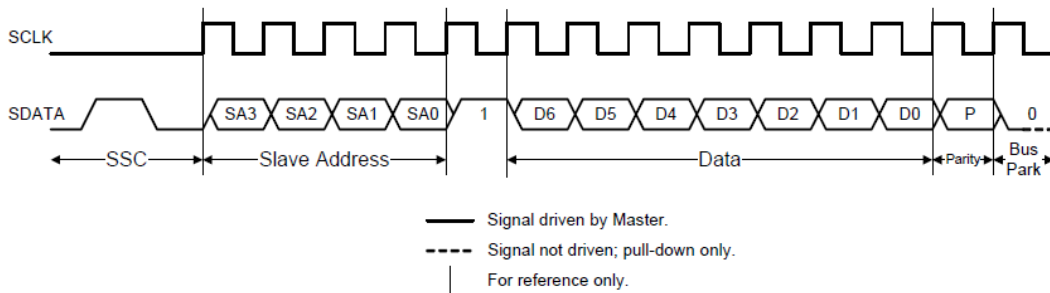

Figure 12. Register 0 Write Command Sequence

Table 24. MIPI RFFE COMMAND FRAME FOR REGISTER 0 WRITE COMMAND SEQUENCE

Description	SSC		Command Frame										BP
SSE & DAC Configuration	1	0	SA [3,0]	1	SSE	DAC_E	DAC_F	DAC_A	DAC_B	DAC_C	DAC_D	P	BP

**Register Write Command Sequence**

The write register command sequence may be used to access each register (addresses 0–31).

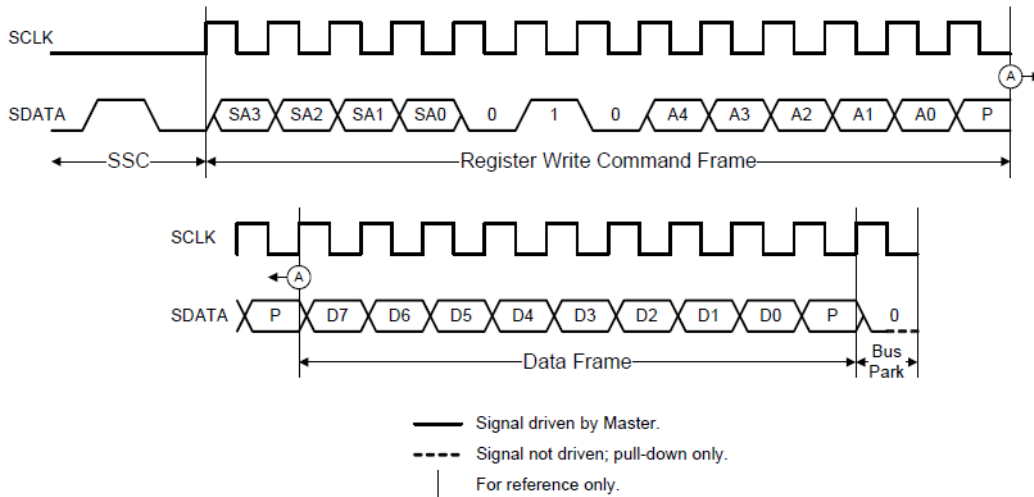

**Figure 13. Register Write Command Sequence**

**Table 25. MIPI RFFE COMMAND FRAME FOR REGISTER WRITE COMMAND SENTENCE**

Description	SSC		Command Frame									Data Frame		BP	
	1	0	SA [3,0]	0	1	0	0	0	0	0	1	P	TC_IND_X_L [7:0]		P
Turbo-Charge Settings	1	0	SA [3,0]	0	1	0	0	0	0	0	1	P	TC_IND_X_L [7:0]	P	BP
Register Write DAC A	1	0	SA [3,0]	0	1	0	0	0	0	1	0	P	TC_IND_X_L [8] & DAC_A [6:0]	P	BP
Register Write DAC B	1	0	SA [3,0]	0	1	0	0	0	0	1	1	P	TC_IND_X_L [9] & DAC_B [6:0]	P	BP
Register Write DAC C	1	0	SA [3,0]	0	1	0	0	0	1	0	0	P	TC_IND_X_L [10] & DAC_C [6:0]	P	BP

**Table 26. MIPI RFFE COMMAND FRAME FOR REGISTER WRITE COMMAND SENTENCE**

Description	SSC		Command Frame									Data Frame		BP	
	1	0	SA [3,0]	0	1	0	0	0	1	0	1	P	TC_IND_X_U [7:0]		P
Turbo-Charge Settings	1	0	SA [3,0]	0	1	0	0	0	1	0	1	P	TC_IND_X_U [7:0]	P	BP
Register Write DAC D	1	0	SA [3,0]	0	1	0	0	0	1	1	0	P	TC_IND_X_U [8] & DAC_D [6:0]	P	BP
Register Write DAC E	1	0	SA [3,0]	0	1	0	0	0	1	1	1	P	TC_IND_X_U [9] & DAC_E [6:0]	P	BP
Register Write DAC F	1	0	SA [3,0]	0	1	0	0	1	0	0	0	P	TC_IND_X_U [10] & DAC_F [6:0]	P	BP

**Extended Register Write Command Sequence**

In order to access more than one register in one sequence this message could be used. Most commonly it will be used for loading three DAC registers at the same time. The four LSBs of the extended register write command frame determine the number of bytes that will be written by the command sequence. A value of 0b0000 would write one byte and a value of 0b1111 would write 16 bytes.

If more than one byte is to be written, the register address in the command sequence contains the address of the first extended register that will be written to and the slave's local extended register address shall be automatically incremented by one for each byte written up to address 0x1F, starting from the address indicated in the address frame.

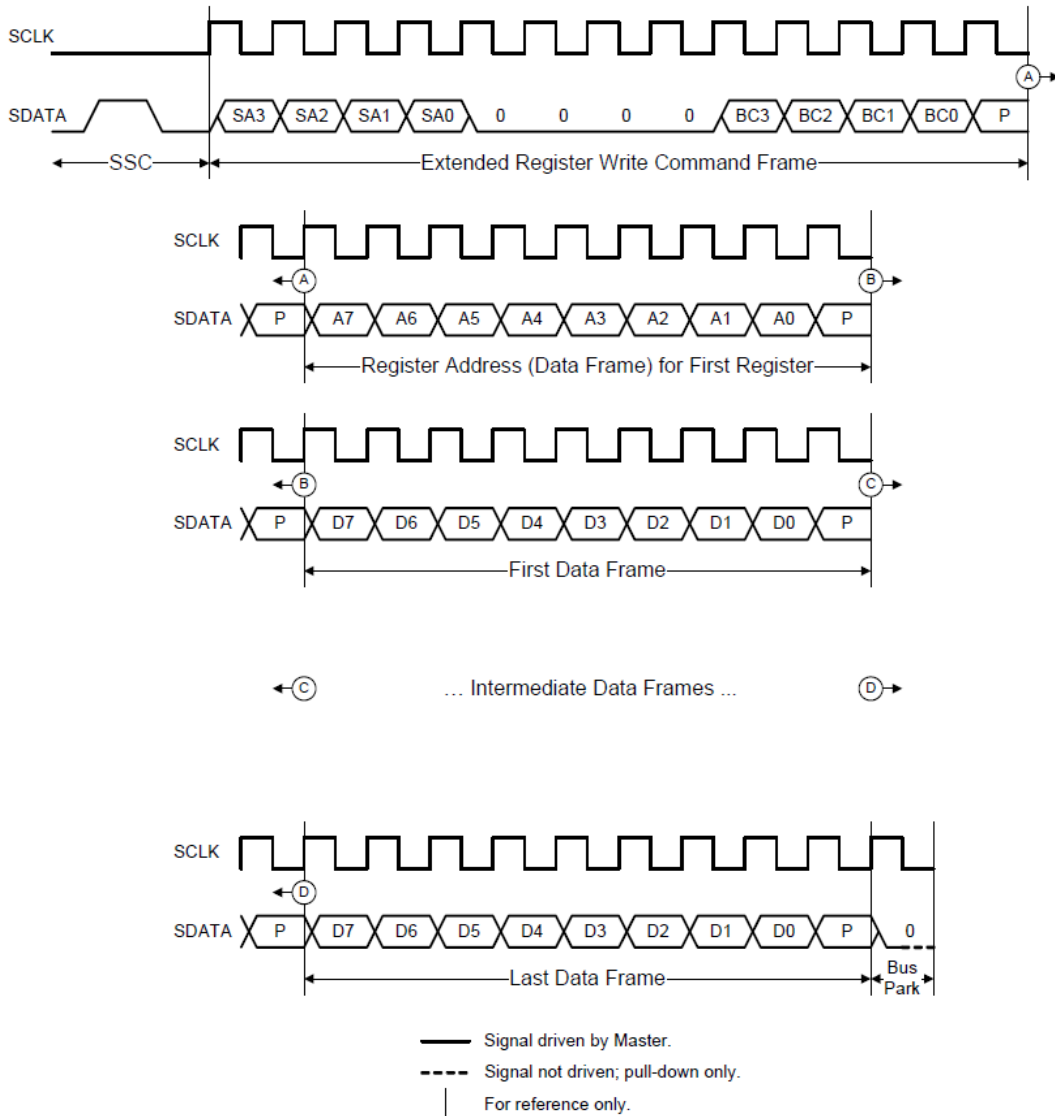

**Figure 14. Extended Register Write Command Sequence**

Table 27. EXTENDED REGISTER WRITE TO UPDATE DAC A, B, C (Note 6)

Description	SSC		Command Frame								Address Frame													
Extended Register Write TC_IND <sub>X</sub> _L and DAC A, B, C										Op Code	<Byte Count>			P	<Starting Address>								P	
	1	0	SA [3,0]			0	0	0	0	0	0	0	1	1	P	0	0	0	0	0	0	0	0	1
Data Frame		Data Frame				Data Frame				Data Frame				BP										
<Data 8-bit>		P	<Data 8-bit>				P	<Data 8-bit>				P	<Data 8-bit>				P	BP						
Turbo-Charge		P	DAC_A [7,0]				P	DAC_B [7,0]				P	DAC_C [7,0]				P	BP						

Table 28. EXTENDED REGISTER WRITE TO UPDATE DAC D, E, F (Note 6)

Description	SSC		Command Frame								Address Frame												
Extended Register Write TC_IND <sub>X</sub> _U and DAC D, E, F										Op Code	<Byte Count>			P	<Starting Address>								P
	1	0	SA [3,0]			0	0	0	0	0	0	0	1	1	P	0	0	0	0	0	1	0	1
Data Frame		Data Frame				Data Frame				Data Frame				BP									
<Data 8-bit>		P	<Data 8-bit>				P	<Data 8-bit>				P	<Data 8-bit>				P	BP					
Turbo-Charge		P	DAC_D [7,0]				P	DAC_E [7,0]				P	DAC_F [7,0]				P	BP					

6. The six DACs can be updated either all together in the same time by using one Extended Register Write command of 8 bytes, or separately by using two Extended Register Write commands of 4 bytes each, where one command is to update DAC A, B, C and the other command to update DAC D, E, F.

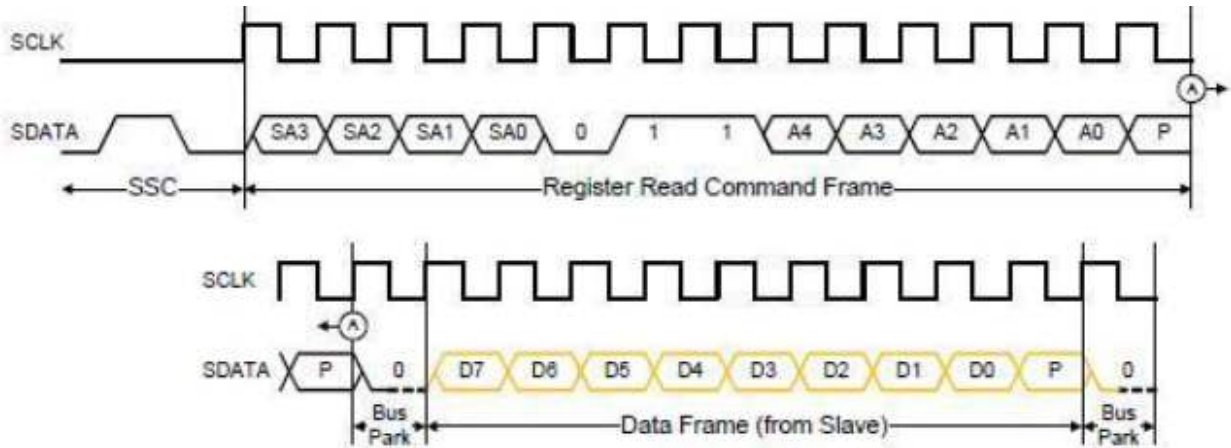

Figure 15. Register Read Command Sequence

Table 29. REGISTER READ COMMAND

Description	SSC		Command Frame										
Read MIPI-RFFE Status Register	1	0	SA[3:0]	0	1	1	1	1	0	1	0	P	BP
Description	Data Frame												
Read MIPI-RFFE Status Register (Continued)	0	CFPE	CLE	AFPE	DFPE	RURE	WURE	BGE	BP				

# TCC-106

Following picture shows TCC-106 and all the necessary external components

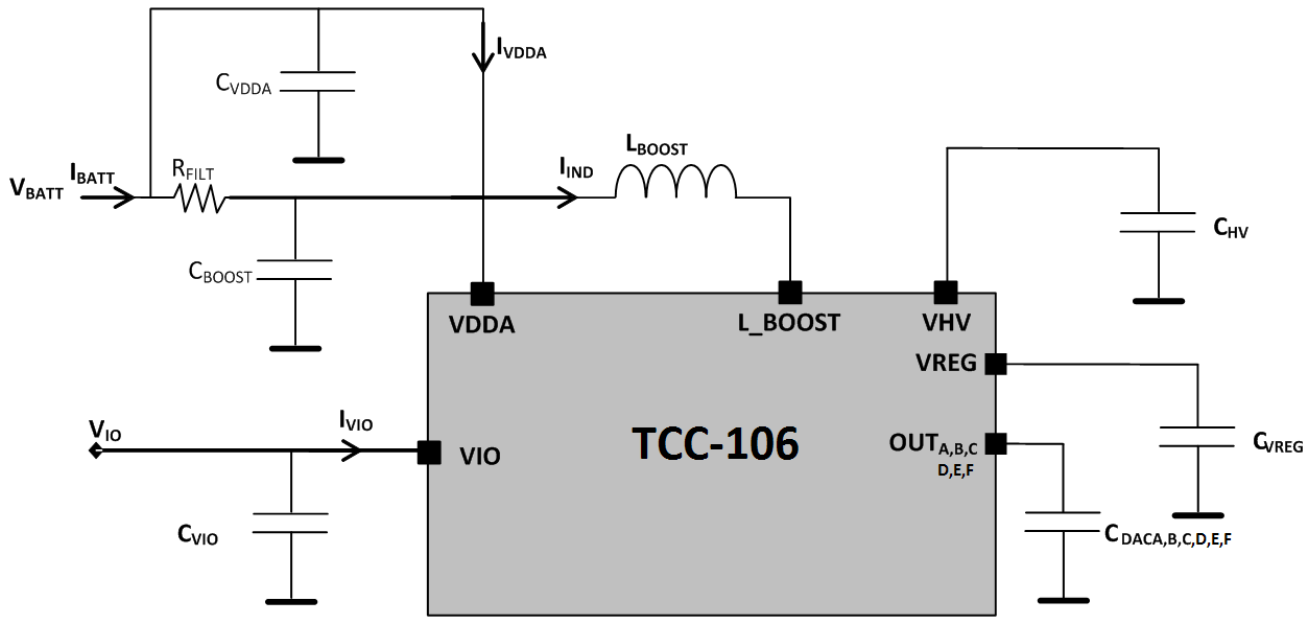

Figure 16. TCC-106 with External Components

Table 30. RECOMMENDED EXTERNAL BOM

Component	Description	Nominal Value	Package	Recommended P/N
C <sub>BOOST</sub>	Boost Supply Capacitor, 10 V	1 $\mu$ F	0402	TDK: C1005X5R1A105K
L <sub>BOOST</sub>	Boost Inductor	15 $\mu$ H	0603	ABCO: LPS181210T-150M, Sunlord SPH201610H150MT
R <sub>FILT</sub>	Filtering resistor, 5%	3.3 ohms	0402	Vishay : CRCW04023R30JNED
C <sub>VIO</sub>	V <sub>IO</sub> Supply Decoupling, 10 V	100 nF	0201	Murata: GRM033R61A104ME15D
C <sub>AVDD</sub>	V <sub>AVDD</sub> Supply Decoupling, 10 V	1 $\mu$ F	0402	TDK: C1005X5R1A105K
C <sub>VREG</sub>	V <sub>VREG</sub> Supply Decoupling, 10 V	220 nF	0201	TDK: C0603X5R1A224M
C <sub>HV</sub>	Boost Tank Capacitor, 50 V	47 nF	1005	Murata: GRM155C71H473KE19
C <sub>dacA,B,C,D,E,F</sub>	Decoupling Capacitor, 50 V (Note 7)	100 pF	0201	Murata: GRM0335C1H101JD01D

7. Recommended for noise reduction only – not essential

# TCC-106

## Mechanical Description: Ball Array Package

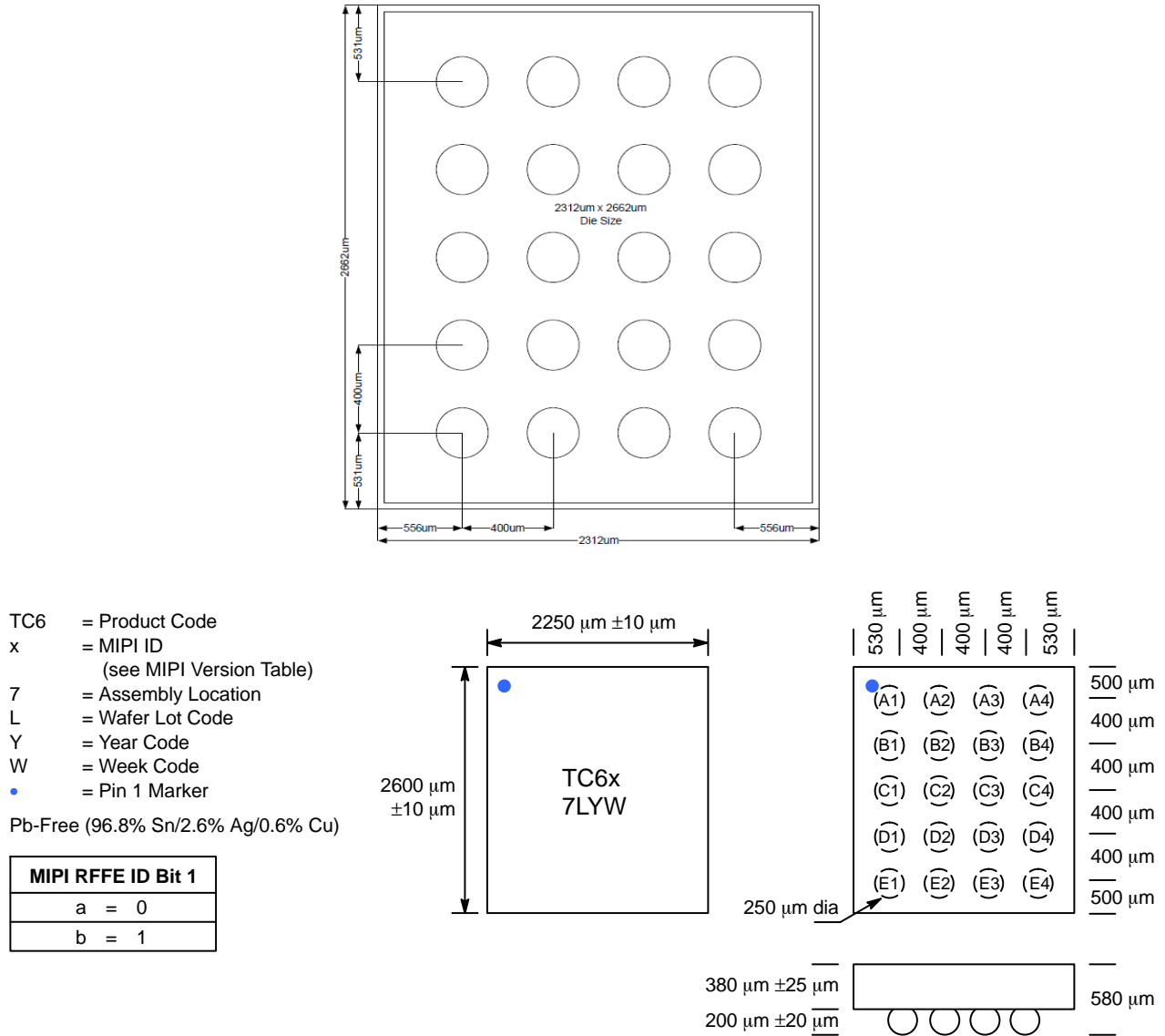

Figure 17. Ball Array Package – Top View

NOTE: Die dimensions include an assumed 60 µm wide sawing kerf, this kerf width is subject to change without notice.

# TCC-106

## Tape & Reel Dimensions

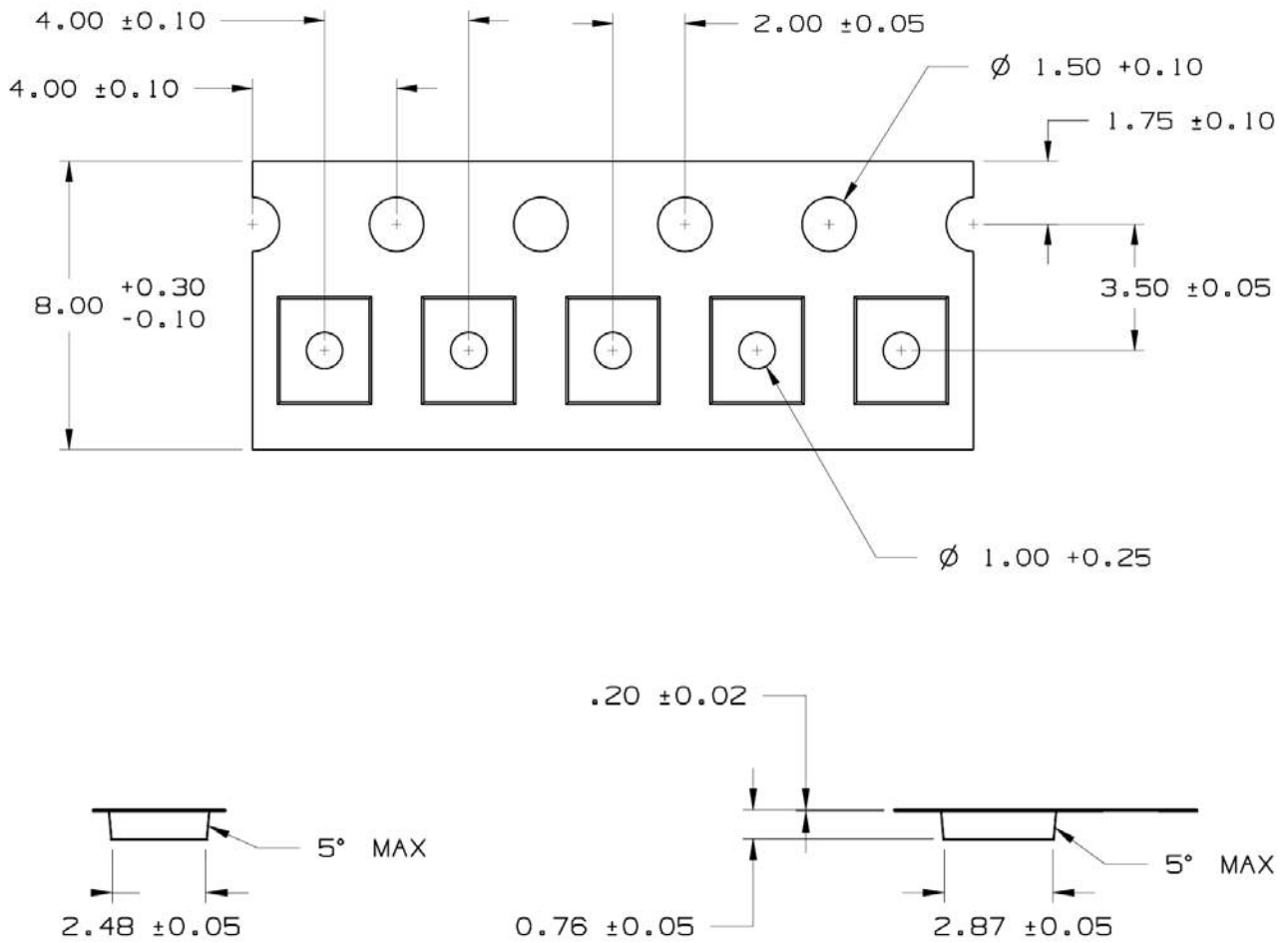

Figure 18. WLCSP Carrier Tape Drawings

Table 31. ORDERING INFORMATION

Device	Package	Shipping†
TCC-106A-RT	RDL (Pb-Free)	3000 / Tape & Reel
TCC-106B-RT	RDL (Pb-Free)	3000 / Tape & Reel

†For information on tape and reel specifications, including part orientation and tape sizes, please refer to our Tape and Reel Packaging Specifications Brochure, BRD8011/D.

# TCC-106

## PACKAGE DIMENSIONS

### WLCSP20, 2.58x2.23 CASE 567HL ISSUE 0

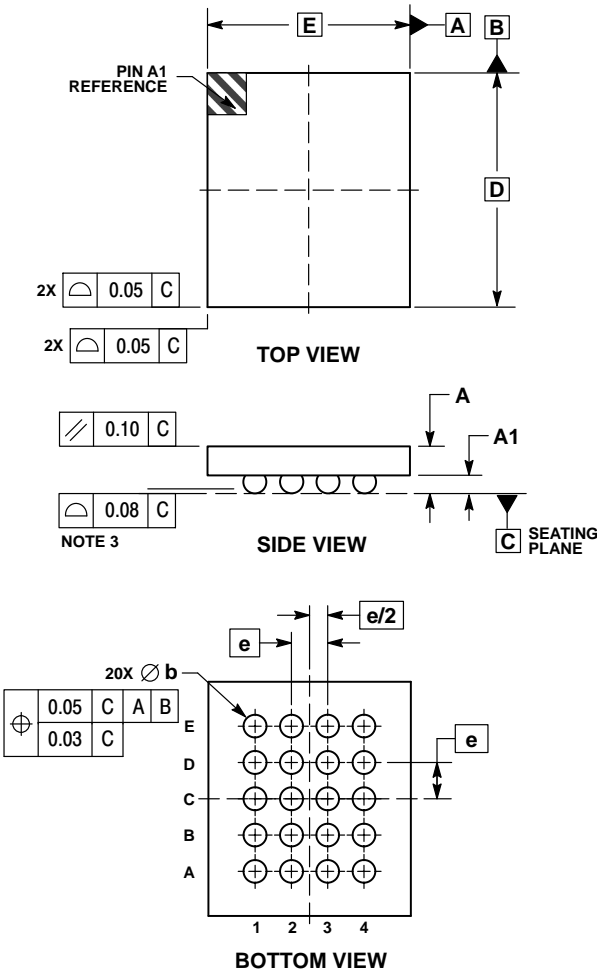

- NOTES:
1. DIMENSIONING AND TOLERANCING PER ASME Y14.5M, 1994.
  2. CONTROLLING DIMENSION: MILLIMETERS.
  3. COPLANARITY APPLIES TO SPHERICAL CROWNS OF SOLDER BALLS.

DIM	MILLIMETERS	
	MIN	MAX
A	—	0.65
A1	0.18	0.22
A3	0.38 REF	
b	0.23	0.29
D	2.58 BSC	
E	2.23 BSC	
e	0.40 BSC	

### RECOMMENDED SOLDERING FOOTPRINT\*

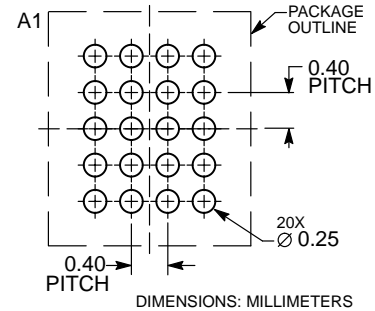

\*For additional information on our Pb-Free strategy and soldering details, please download the ON Semiconductor Soldering and Mounting Techniques Reference Manual, SOLDERRM/D.

ON Semiconductor and are registered trademarks of Semiconductor Components Industries, LLC (SCILLC). SCILLC owns the rights to a number of patents, trademarks, copyrights, trade secrets, and other intellectual property. A listing of SCILLC's product/patent coverage may be accessed at [www.onsemi.com/site/pdf/Patent-Marking.pdf](http://www.onsemi.com/site/pdf/Patent-Marking.pdf). SCILLC reserves the right to make changes without further notice to any products herein. SCILLC makes no warranty, representation or guarantee regarding the suitability of its products for any particular purpose, nor does SCILLC assume any liability arising out of the application or use of any product or circuit, and specifically disclaims any and all liability, including without limitation special, consequential or incidental damages. "Typical" parameters which may be provided in SCILLC data sheets and/or specifications can and do vary in different applications and actual performance may vary over time. All operating parameters, including "Typicals" must be validated for each customer application by customer's technical experts. SCILLC does not convey any license under its patent rights nor the rights of others. SCILLC products are not designed, intended, or authorized for use as components in systems intended for surgical implant into the body, or other applications intended to support or sustain life, or for any other application in which the failure of the SCILLC product could create a situation where personal injury or death may occur. Should Buyer purchase or use SCILLC products for any such unintended or unauthorized application, Buyer shall indemnify and hold SCILLC and its officers, employees, subsidiaries, affiliates, and distributors harmless against all claims, costs, damages, and expenses, and reasonable attorney fees arising out of, directly or indirectly, any claim of personal injury or death associated with such unintended or unauthorized use, even if such claim alleges that SCILLC was negligent regarding the design or manufacture of the part. SCILLC is an Equal Opportunity/Affirmative Action Employer. This literature is subject to all applicable copyright laws and is not for resale in any manner.

### PUBLICATION ORDERING INFORMATION

**LITERATURE FULFILLMENT:**  
Literature Distribution Center for ON Semiconductor  
P.O. Box 5163, Denver, Colorado 80217 USA  
**Phone:** 303-675-2175 or 800-344-3860 Toll Free USA/Canada  
**Fax:** 303-675-2176 or 800-344-3867 Toll Free USA/Canada  
**Email:** [orderlit@onsemi.com](mailto:orderlit@onsemi.com)

**N. American Technical Support:** 800-282-9855 Toll Free  
USA/Canada  
**Europe, Middle East and Africa Technical Support:**  
Phone: 421 33 790 2910  
**Japan Customer Focus Center**  
Phone: 81-3-5817-1050

**ON Semiconductor Website:** [www.onsemi.com](http://www.onsemi.com)  
**Order Literature:** <http://www.onsemi.com/orderlit>  
For additional information, please contact your local Sales Representative