

Data Sheet

Customer :

Product : Tantalum Nitride Thin Film Precision Chip Resistor - TAR Series

Size: 0402/0603/0805/1206

Issued Date: 26-Jan-22

Edition : REV A1



VIKING TECH CORPORATION
光韻科技股份有限公司

No.70, Guangfu N. Rad.,
Hsin Chu Industrial Park,
Hukou Hsiang, Hsin Chu Hsien,
303, Taiwan

TEL:886-3-5972931
FAX:886-3-5972935•886-3-5973494
E-mail:sales@viking.com.tw

VIKING TECH CORPORATION KAOHSIUNG BRANCH
光韻科技股份有限公司高雄分公司

No.248-3, Sin-Sheng Rd., Cian-Jhen Dist., Kaohsiung,
806, Taiwan

TEL:886-7-8217999
FAX:886-7-8228229
E-mail:sales@viking.com.tw

Viking Electronics (WUXI) CO., LTD.
光韻電子(無錫)有限公司

No.1A,(Xixia Road),Machinery & Industry Park,
National Hi-Tech Industrial Development Zone of
Wuxi, Wuxi, Jiangsu Province, China
Zip Code:214028

TEL:86-510-85203339
FAX:86-510-85203667•86-510-85203977
E-mail:wuxisales@tmtec.com.tw

Produced by (QC)	Checked (QC)	Approved by (QC)	Prepared by (Sales)	Accepted by (Customer)
26-Jan-22	26-Jan-22	26-Jan-22		
Chun	Ben Chang	Ben Chang		

Tantalum Nitride Thin Film Precision Chip Resistor (TAR Series)

■ Features

- Tantalum nitride thin film resistor
- High stability in humid environments
- AEC-Q200 Compliance
- Tight tolerance down to $\pm 0.05\%$
- Extremely low TCR down to $\pm 10\text{PPM}/^\circ\text{C}$
- Resistance values from 10 ohm to 1M ohm
- Special materials, design, and processing for high sulfur applications
- Test proven immunity to humidity, moisture, and sulfur



■ Applications

- Automotive
- Medical Equipment
- Testing / Measurement Equipment
- Automatic Equipment Controller
- Converters
- Communication Device

■ Construction

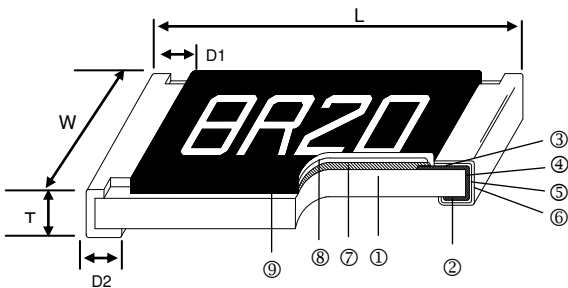

① Alumina Substrate	④ Edge Electrode	⑦ Resistor Layer
② Bottom Electrode	⑤ Barrier Layer	⑧ Overcoat
③ Top Electrode	⑥ External Electrode	⑨ Marking

■ Dimensions

Unit: mm

Type	Size (Inch)	L	W	T	D1	D2	Weight (g) (1000pcs)
TAR02	0402	1.00 \pm 0.05	0.50 \pm 0.05	0.30 \pm 0.05	0.20 \pm 0.10	0.20 \pm 0.10	0.54
TAR03	0603	1.55 \pm 0.10	0.80 \pm 0.10	0.45 \pm 0.10	0.30 \pm 0.20	0.30 \pm 0.20	1.83
TAR05	0805	2.00 \pm 0.15	1.25 \pm 0.15	0.55 \pm 0.10	0.30 \pm 0.20	0.40 \pm 0.20	4.71
TAR06	1206	3.05 \pm 0.15	1.55 \pm 0.15	0.55 \pm 0.10	0.42 \pm 0.20	0.35 \pm 0.25	9.02

■ Part Numbering

TAR	03	A	T	C	M	1001	N
Product Type	Dimensions (L×W)	Resistance Tolerance	Packaging Code	TCR (PPM/ $^\circ$ C)	Power Rating	Resistance	Marking Code
	02: 0402 03: 0603 05: 0805 06: 1206	A: $\pm 0.05\%$ B: $\pm 0.1\%$ C: $\pm 0.25\%$ D: $\pm 0.5\%$ F: $\pm 1\%$	T: Taping Reel B: Bulk	B: ± 10 N: ± 15 C: ± 25 D: ± 50	Y: 1/16W M: 1/6W P: 1/5W U: 1/2W	0010: 1 Ω 1001: 1K Ω 1004: 1M Ω	: Standard Marking for E96 / E24 N: No Marking

Derating Curve

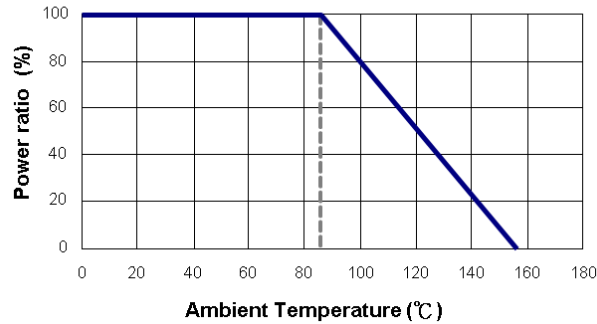

Standard Electrical Specifications

Type	Item	Power Rating at 85°C	Operating Temp. Range	Max. Operating Voltage	Max. Overload Voltage	Resistance Range					TCR (PPM/°C)
						±0.05%	±0.1%	±0.25%	±0.5%	±1%	
TAR02 (0402)		1/16W	-55 ~ +155°C	50V	100V	40Ω – 35KΩ					±10,±15,±25,±50
TAR03 (0603)		1/6W	-55 ~ +155°C	75V	150V	40Ω – 130KΩ					±10,±15,±25,±50
TAR05 (0805)		1/5W	-55 ~ +155°C	100V	200V	10Ω – 350KΩ					±10,±15,±25,±50
TAR06 (1206)		1/2W	-55 ~ +155°C	200V	400V	10Ω – 1MΩ					±10,±15,±25,±50

Operating Voltage= $\sqrt{P \cdot R}$ or Max. operating voltage listed above, whichever is lower.
 Overload Voltage= $2.5 \cdot \sqrt{P \cdot R}$ or Max. overload voltage listed above, whichever is lower.

Environmental Characteristics

Item	Requirement	Test Method
Temperature Coefficient of Resistance (T.C.R.)	As Spec.	JIS-C-5201-1 4.8 IEC-60115-1 4.8 -55°C~+125°C, 25°C is the reference temperature
Short Time Overload	$\Delta R \pm 0.1\%$	JIS-C-5201-1 4.13 RCWV*2.5 or Max. overload voltage whichever is lower for 5 seconds
Insulation Resistance	>1000 MΩ	JIS-C-5201-1 4.6 IEC-60115-1 4.6 Apply 100V _{DC} for 1 minute
Operational Life	$\Delta R \pm 0.1\%$	MIL-STD-202 Method 108 Condition D Steady State T _A =125°C at derated power. Measurement at 24±4 hours after test conclusion.
Biased Humidity	$\Delta R \pm 0.1\%$	MIL-STD-202 Method 103 1000 hrs 85°C/85%RH 10% of operating power.
High Temperature Exposure	$\Delta R \pm 0.15\%$	MIL-STD-202 Method 108 at +155°C for 1000 hrs
Temperature Cycling	$\Delta R \pm 0.1\%$ for 125°C	JESD22 Method JA-104 -55°C to +125°C, 1000 cycles -55°C to +155°C, 1000 cycles
	$\Delta R \pm 0.2\%$ for 155°C	
Bending Strength (Board Flex)	$\Delta R \pm 0.1\%$	JIS-C-5201-1 4.33 Bending 2mm for 60 seconds
Solderability	95% min. coverage	JIS-C-5201-1 4.17 IEC-60115-1 4.17 245±5°C for 3 seconds
Resistance to Soldering Heat	$\Delta R \pm 0.1\%$	JIS-C-5201-1 4.18 IEC-60115-1 4.18 260±5°C for 10 seconds

Terminal strength	No broken	AEC-Q200-006 Force of 1kg for 60 seconds.
Mechanical Shock	$\Delta R \pm 0.1\%$	MIL-STD-202 Method 213 Wave Form: Tolerance for half sine shock pulse. Peak value is 100g's. Normal duration (D) is 6.
Vibration	$\Delta R \pm 0.1\%$	MIL-STD-202 Method 204 5 g's for 20 min., 12 cycles each of 3 orientations, 10-2000 Hz
ESD	$\Delta R \pm 0.1\%$	AEC-Q200-002 Human body model TAR02 · TAR03 0.2KV TAR05 · TAR06 1KV
Resistance to solvents	Marking Unsmearred	MIL-STD-202 Method 215 Add Aqueous wash chemical - OKEM Clean or equivalent. Do not use banned solvents.
Sulfur Test	$\Delta R \pm 1\%$	EIA-977(Conditions B) 105±2 °C no power rating for 750 hrs.
Flammability	No ignition of the tissue paper or scorching or the pinewood board	UL-94 V-0 or V-1 are acceptable. Electrical test not required.
Endurance	$\Delta R \pm 0.1\%$	IEC60115-1 4.25 1000 +48/-0 hours, loaded with RCWV or Vmax in chamber controller 85 ±2°C, 1.5 hours on and 0.5 hours off
Moisture Resistance	$\Delta R \pm 0.1\%$	MIL-STD-202 Method 106 65±2°C, 80~100% RH, 10 cycles, 24 hours/cycle

RCWV(Rated continuous working voltage)= $\sqrt{P \cdot R}$ or Max. Operating voltage whichever is lower

- Storage Temperature: 15~28°C; Humidity < 80%RH
- Shelf Life: 2 years from production date.

■ Soldering Condition(IPC/JEDEC J-STD-020)

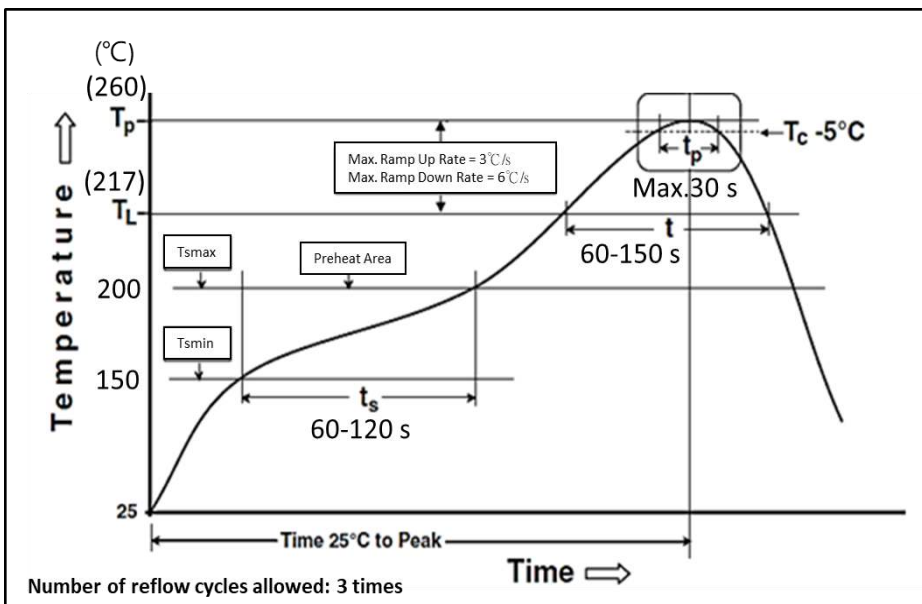

■ Marking

0603 3digit marking

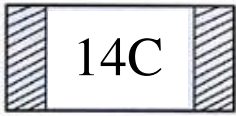

3digit marking for Example: 14C=13K7Ω 13C=13K3Ω
 68B=4K99Ω 68X=49.9Ω

Marking Table

Code	E96	Code	E96	Code	E96	Code	E96				
01	100	25	178	49	316	73	562				
02	102	26	182	50	324	74	576				
03	105	27	187	51	332	75	590				
04	107	28	191	52	340	76	604				
05	110	29	196	53	348	77	619				
06	113	30	200	54	357	78	634				
07	115	31	205	55	365	79	649				
08	118	32	210	56	374	80	665				
09	121	33	215	57	383	81	681				
10	124	34	221	58	392	82	698				
11	127	35	226	59	402	83	715				
12	130	36	232	60	412	84	732				
13	133	37	237	61	422	85	750				
14	137	38	243	62	432	86	768				
15	140	39	249	63	442	87	787				
16	143	40	255	64	453	88	806				
17	147	41	261	65	464	89	825				
18	150	42	267	66	475	90	845				
19	154	43	274	67	487	91	866				
20	158	44	280	68	499	92	887				
21	162	45	287	69	511	93	909				
22	165	46	294	70	523	94	931				
23	169	47	301	71	536	95	953				
24	174	48	309	72	549	96	976				
Code	A	B	C	D	E	F	G	H	X	Y	Z
Multiplier	10 ⁰	10 ¹	10 ²	10 ³	10 ⁴	10 ⁵	10 ⁶	10 ⁷	10 ⁻¹	10 ⁻²	10 ⁻³

0603 3digit marking for E24

Example: 101=100Ω 102=1KΩ

E24	10	11	12	13	15	16	18	20	22	24	27	30	33	36	39	43	47	51	56	62	68	75	82	91
-----	----	----	----	----	----	----	----	----	----	----	----	----	----	----	----	----	----	----	----	----	----	----	----	----

0805~1206 4digit marking

Example

Resistance	100Ω	2.2KΩ	10KΩ	49.9KΩ	100KΩ
marking	1000	2201	1002	4992	1003

■Packaging

Packing Quantity & Reel Specifications

Unit :mm

Type	ØA	ØB	ØC	W	T	Paper Tape (EA)	Emboss Plastic Tape (EA)
TAR02	178.0±1.0	60.0+1.0	13.5±0.7	9.5±1.0	11.5±1.0	10,000	-
TAR03	178.0±1.0	60.0+1.0	13.5±0.7	9.5±1.0	11.5±1.0	5,000	-
TAR05	178.0±1.0	60.0+1.0	13.5±0.7	9.5±1.0	11.5±1.0	5,000	-
TAR06	178.0±1.0	60.0+1.0	13.5±0.7	9.5±1.0	11.5±1.0	5,000	-

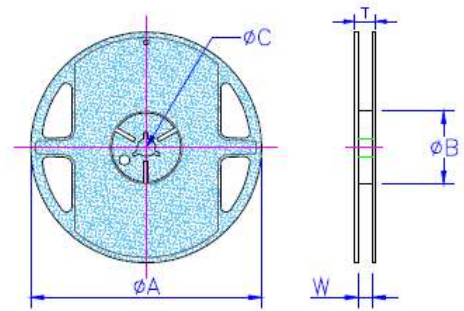

Paper Tape Specifications

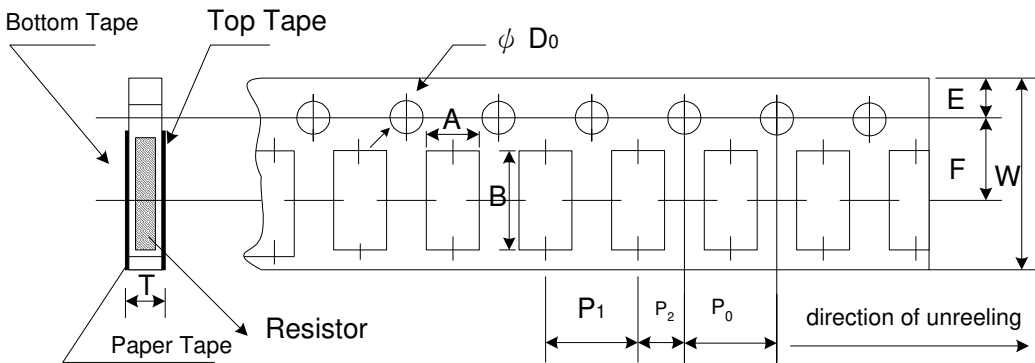

Unit: mm

Type	A	B	W	E	F	P ₀	P ₁	P ₂	ΦD ₀	T
TAR02	0.70±0.05	1.16±0.05	8.00±0.10	1.75±0.05	3.5±0.05	4.00±0.10	2.00±0.05	2.00±0.05	1.55±0.05	0.40±0.03
TAR03	1.10±0.05	1.90±0.05	8.00±0.10	1.75±0.05	3.5±0.05	4.00±0.10	4.00±0.10	2.00±0.05	1.55±0.05	0.60±0.03
TAR05	1.60±0.05	2.37±0.05	8.00±0.10	1.75±0.05	3.5±0.05	4.00±0.10	4.00±0.10	2.00±0.05	1.55±0.05	0.75±0.05
TAR06	2.00±0.05	3.55±0.05	8.00±0.10	1.75±0.05	3.5±0.05	4.00±0.10	4.00±0.10	2.00±0.05	1.55±0.05	0.75±0.05

- Peel force of top cover tape
- The peel speed shall be about 300mm/min±5%
- The peel force of top cover tape shall be between 8gf to 60gf

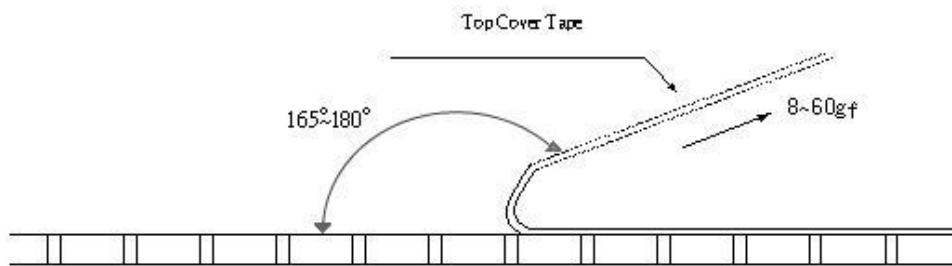

■Recommend Land Pattern

Unit: mm

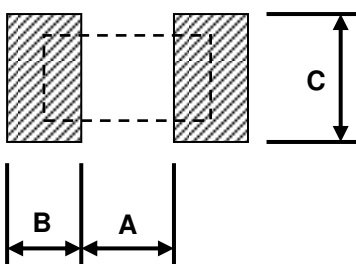

Type	A	B	C
TAR02	0.50	0.50	0.60±0.2
TAR03	0.80	1.00	0.90±0.2
TAR05	1.00	1.00	1.35±0.2
TAR06	2.00	1.15	1.70±0.2

REVISION	DATE	CHANGE NOTIFICATION	DESCRIPTION
Version A1	Jan 26 ,2022	-	- Add shelf life description. - Modify IR reflow profile to comply IPC/JEDEC J-STD-020.