

Absolute maximum ratings

($T_a=25^\circ\text{C}$)

Symbol	Ratings		Unit
	N channel	P channel	
V_{DSS}	60	-60	V
V_{GSS}	± 20	± 20	V
I_D	6	-6	A
$I_{D(\text{pulse})}$	10 ($PW \leq 1\text{ms}$, $\text{duty} \leq 25\%$)	-10 ($PW \leq 1\text{ms}$, $\text{duty} \leq 25\%$)	A
P_T	5 ($T_a=25^\circ\text{C}$, with all circuits operating, without heatsink)		W
	35 ($T_c=25^\circ\text{C}$, with all circuits operating, with infinite heatsink)		W
θ_{j-a}	25 (Junction-Air, $T_a=25^\circ\text{C}$, with all circuits operating)		$^\circ\text{C/W}$
θ_{j-c}	3.57 (Junction-Case, $T_c=25^\circ\text{C}$, with all circuits operating)		$^\circ\text{C/W}$
V_{ISO}	1000 (Between fin and lead pin, AC)		Vrms
T_{ch}	150		$^\circ\text{C}$
T_{stg}	-40 to +150		$^\circ\text{C}$

Equivalent circuit diagram

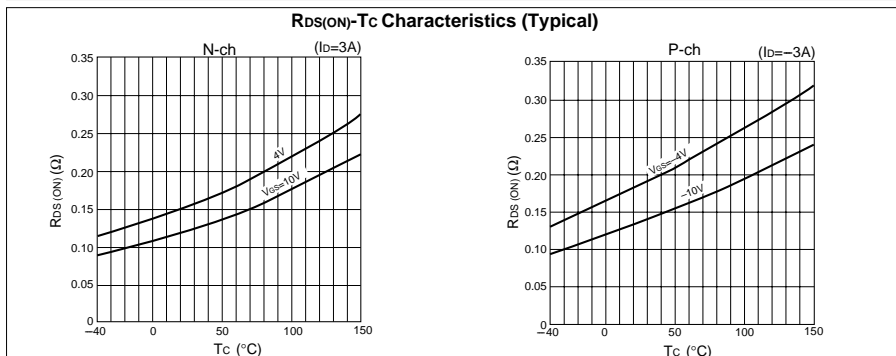
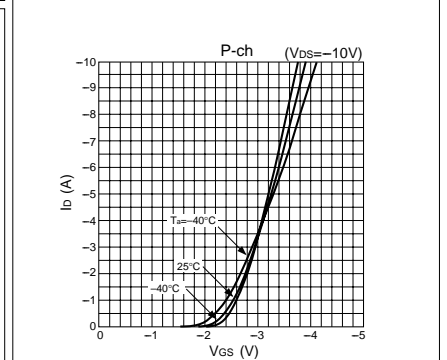
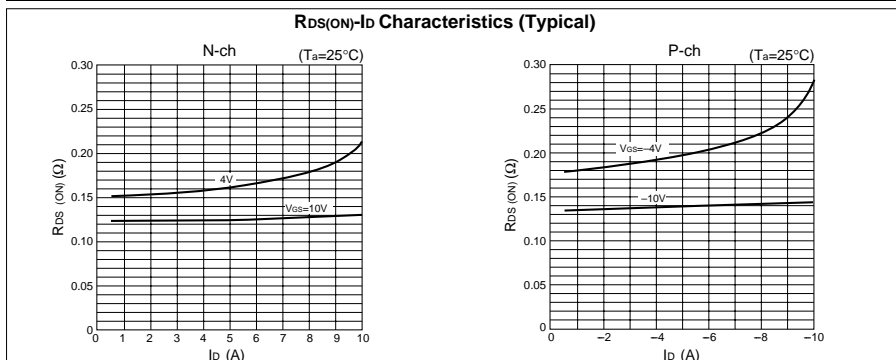
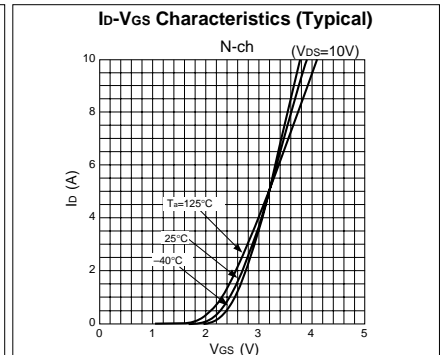
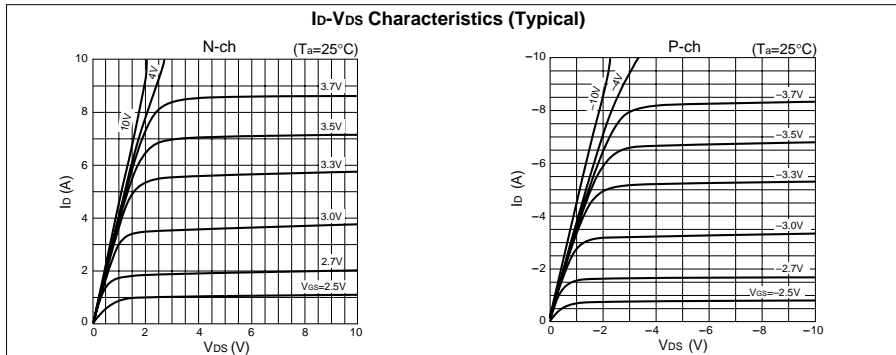
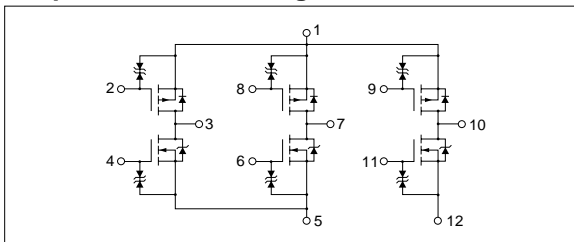

Electrical characteristics

(Ta=25°C)

Symbol	N channel					P channel				
	Specification			Unit	Conditions	Specification			Unit	Conditions
	min	typ	max			min	typ	max		
V(BR)DSS	60			V	Id=100μA, VGS=0V	-60			V	Id=-100μA, VGS=0V
IGSS			±10	μA	VGS=±20V			±10	μA	VGS=±20V
IDSS			100	μA	VDS=60V, VGS=0V			-100	μA	VDS=-60V, VGS=0V
VTH	1.0		2.0	V	VDS=10V, Id=250μA	-1.0		-2.0	V	VDS=-10V, Id=-250μA
Re(yfs)		5.5		S	VDS=10V, Id=3A		6		S	VDS=-10V, Id=-3A
RDS(ON)			0.22	Ω	VGS=4V, Id=3A		0.22		Ω	VGS=-10V, Id=-3A
Ciss		320		pF	VDS=10V, f=1.0MHz, VGS=0V		790		pF	VDS=-10V, f=1.0MHz, VGS=0V
Coss		160		pF			310		pF	
Crss		35		pF			90		pF	
td(on)		16		ns	Id=3A, VDD=20V, RL=6.67Ω, VGS=5V, see Fig. 3 on page 16.		40		ns	Id=-3A, VDD=20V, RL=6.67Ω, VGS=-5V, see Fig. 4 on page 16.
tr		65		ns			110		ns	
td(off)		70		ns			160		ns	
tf		45		ns			80		ns	
VSD		1.2		V		ISD=6A, VGS=0V		-1.1		
trr		65		ns	ISD=3A, VGS=0V, di/dt=100A/μs		85		ns	ISD=-3A, VGS=0V, di/dt=100A/μs

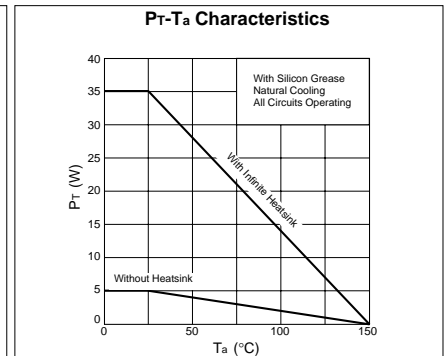
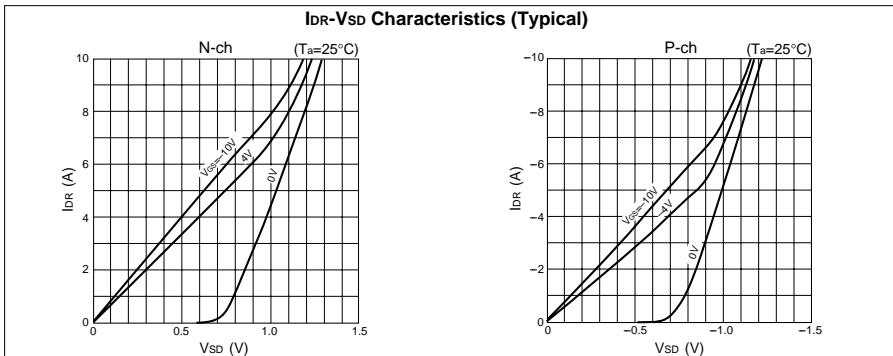
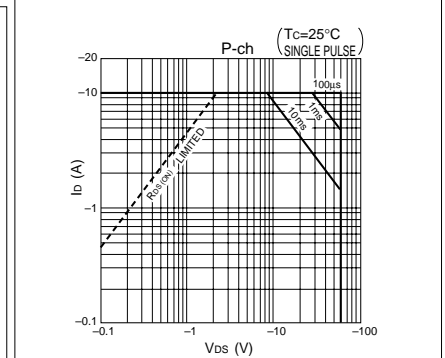
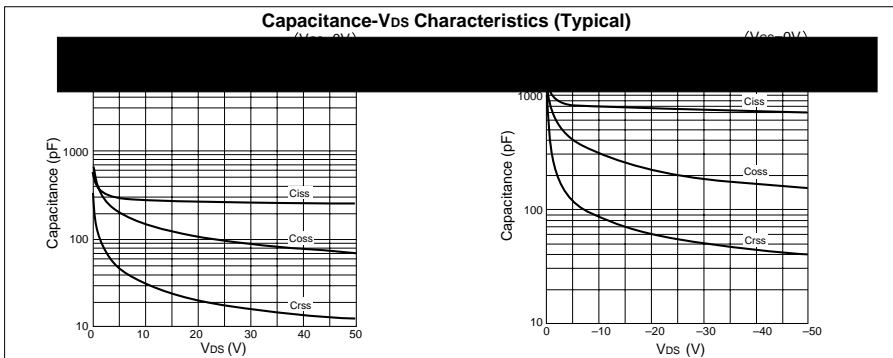
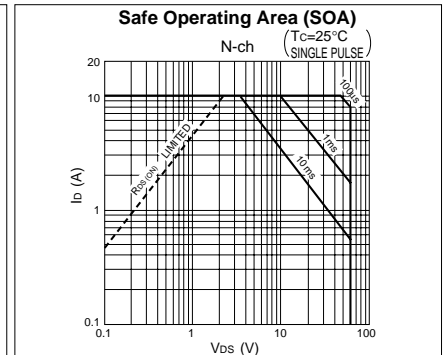
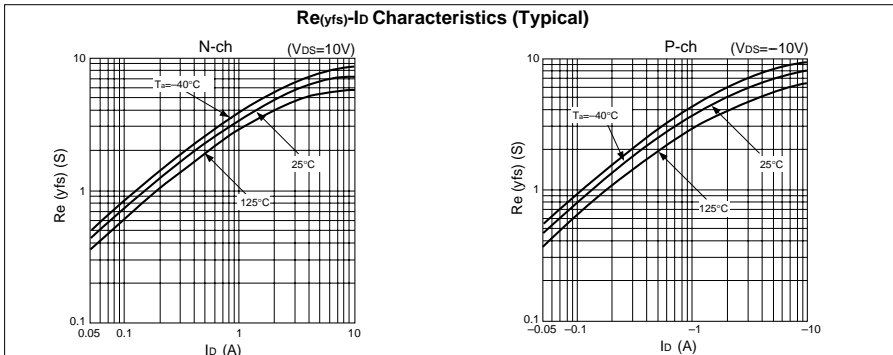

• SIP 8 (STA8Pin)

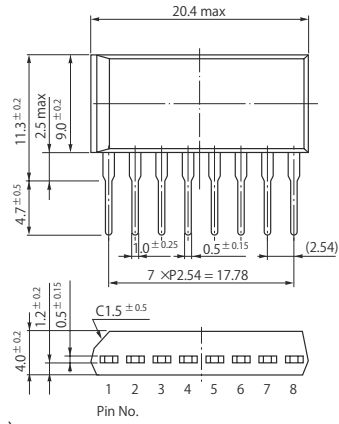

• SIP 10 (STA10Pin)

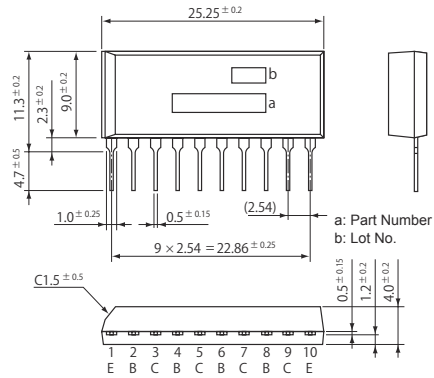

• SIP 12 (SMA12Pin)

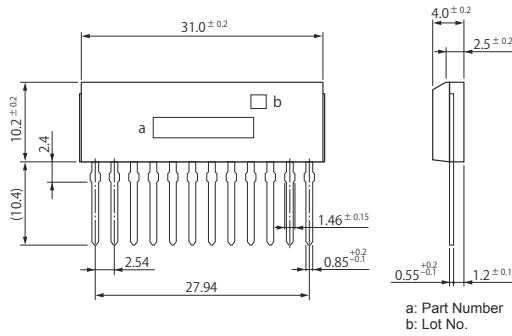

• SIP 15 (SMA15Pin)

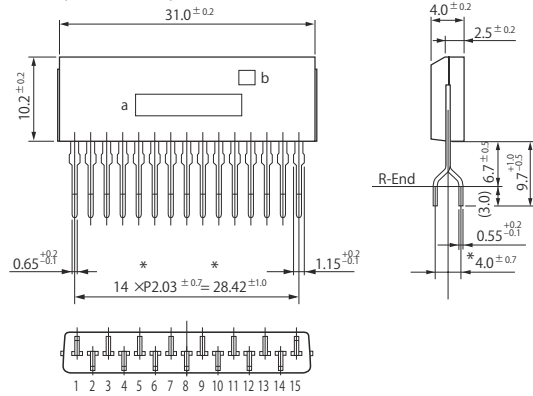

• SIP 12 with Fin (SLA12Pin)

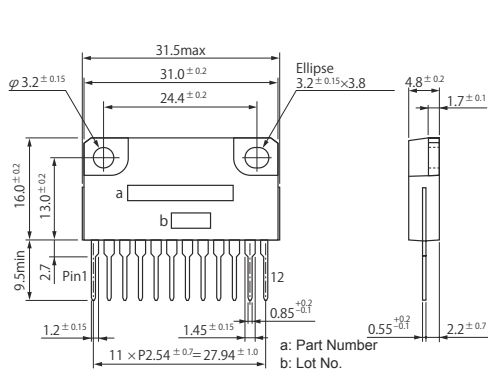

• SIP 15 with Fin (SLA15Pin)

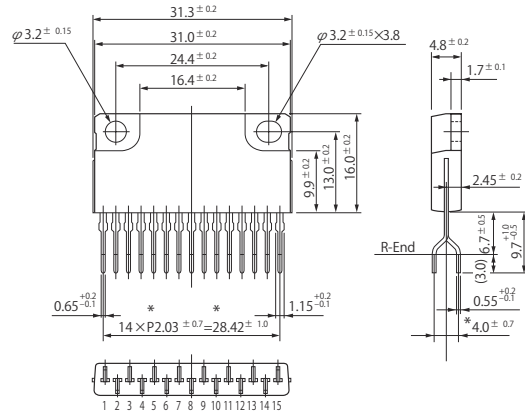

• SIP 21 with Fin (SLA21Pin)

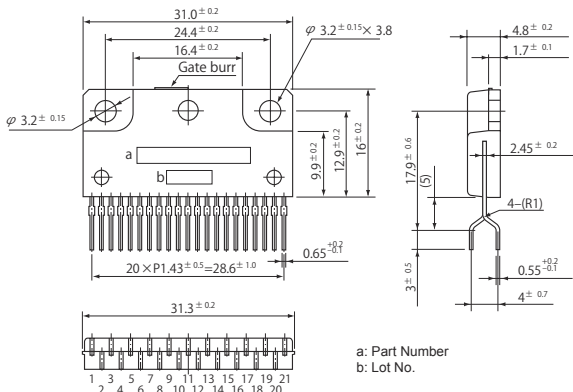

(Unit:mm)