

Customer Information Sheet

DRAWING No.: KAI-1410005

IF IN DOUBT - ASK

©

NOT TO SCALE

THIRD ANGLE PROJECTION

ALL DIMENSIONS IN mm

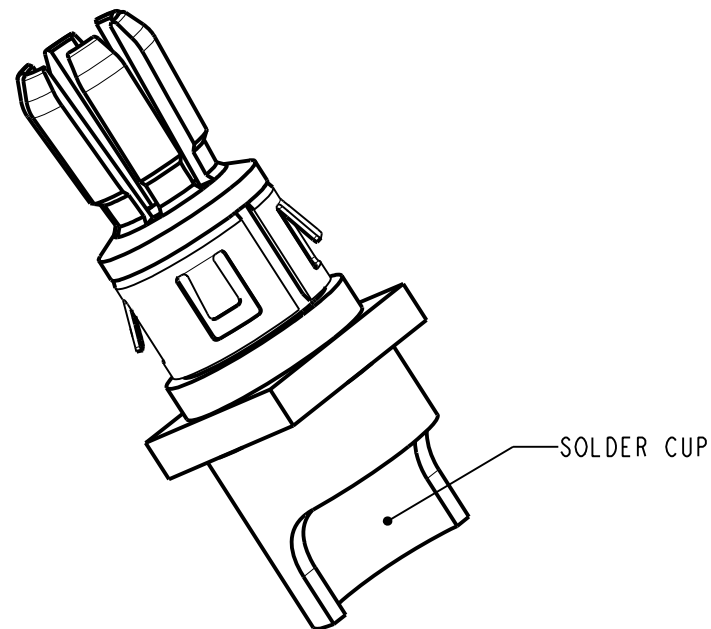
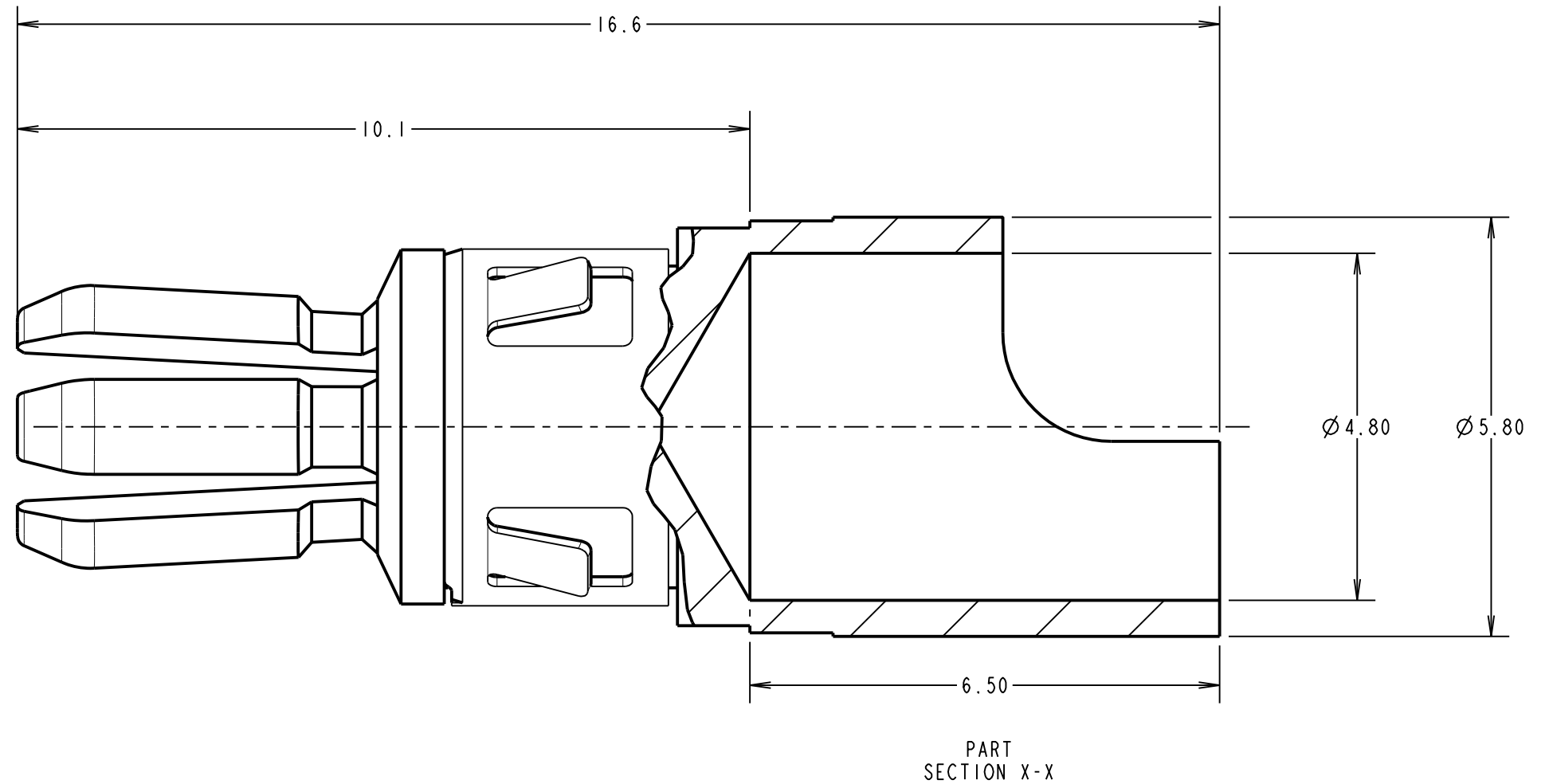
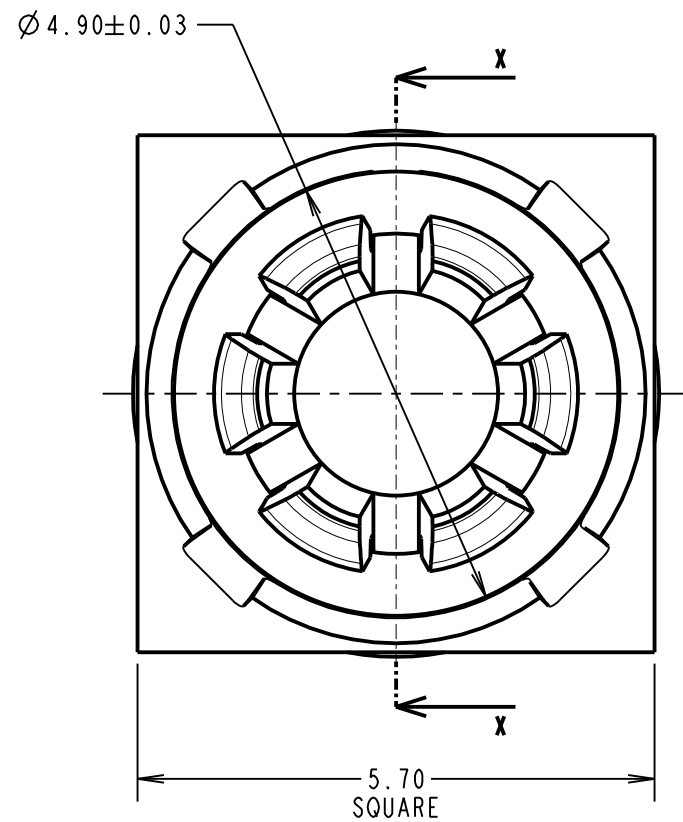

NOTES:

1. STRIP WIRE BY 7.0mm.
2. CONTACT EXTRACTION TOOL = ZAI-9040000. FOR MORE INFORMATION SEE IS-49.
3. FOR ALL OTHER ELECTRICAL / MECHANICAL REQUIREMENTS, SEE COMPONENT SPECIFICATION C052XX (LATEST ISSUE).
4. MAX WIRE CONDUCTOR SIZE = $\varnothing 4.24\text{mm}$ / 8AWG.
MAX WIRE INSULATION DIAMETER = 7.50mm.
5. PACK SIZE = 10.

MR	I	09.08.22	31804
NAME	ISS.	DATE	CN/CO
APPROVED: M.RUDKIN			
CHECKED: R.PORTLOCK			
DRAWN: M.RUDKIN			
CUSTOMER REF.:			
ASSEMBLY DRG:			

HARWIN

www.harwin.com
technical@harwin.com

THIS DRAWING AND ANY INFORMATION OR DESCRIPTIVE MATTER SET OUT HEREON ARE CONFIDENTIAL AND COPYRIGHT PROPERTY OF THE HARWIN GROUP AND MUST NOT BE DISCLOSED, LOANED, COPIED OR USED FOR MANUFACTURING, TENDERING OR FOR ANY OTHER PURPOSE WITHOUT THEIR WRITTEN PERMISSION.

TOLERANCES

X. = $\pm 1\text{mm}$
X.X = $\pm 0.50\text{mm}$
X.XX = $\pm 0.20\text{mm}$
X.XXX = $\pm 0.01\text{mm}$
ANGLES = $\pm 5^\circ$
UNLESS STATED

MATERIAL:

SEE ABOVE

FINISH: GOLD OVER NICKEL

S/AREA: mm²

TITLE:

KONA SERIES - MALE CONTACT WITH LATCHING COLLAR

DRAWING NUMBER:

KAI-1410005

SHT
2 OF 2