

## MS-215-7



## MS-215-7

Normally Closed Reed Sensor

Electrical Characteristics		@ 25 °C
Contact form		B
Contact rating max.	W / VA	5
Switching voltage max.	VDC	175
	VAC	120
Switching current max.	A	0.25
Carry current max.	A	1.5
Breakdown voltage min.	VDC	200
Total resistance max. (initial)	mΩ	200
Insulation resistance min.	Ω	10 <sup>9</sup>

Features
➤ Compact size
➤ Mechanically protected
➤ Non pole oriented actuation
➤ Customized types available

Magnetical Characteristics (of unmodified Reed Switch)		@ 25 °C
Pull in range available	AT	15 - 30
Drop out min.	AT	5
Test coil	TC	200
Test equipment tolerance	± AT	2

Approvals

Operating Characteristics (of unmodified Reed Switch)		@ 25 °C
Switching frequency max.	Hz	100
Resonant frequency typ.	Hz	1100
Operate time max. (incl. bounce)	ms	0.7
Release time max.	ms	1

Environmental Characteristics	
Operating temperature	°C -20 to +85
Vibration (50-2000 Hz)	g 30
Shock (1/2 sin 11 ms)	g 50

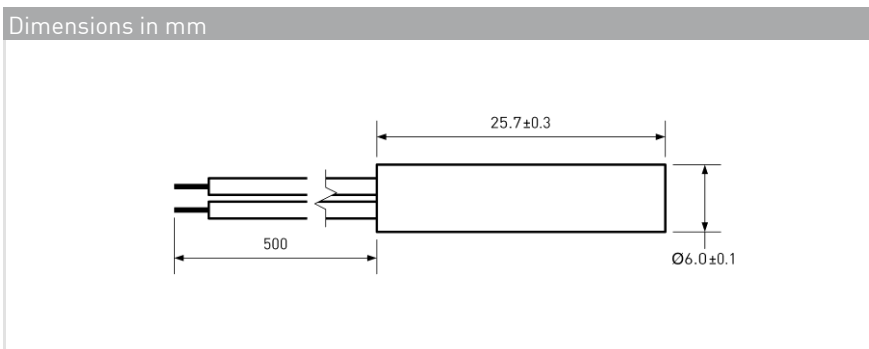

Ordering Information	
Packing Unit	50 pcs
Weight per piece	3.8 g
Weight per package	195 g
Standard AT Ranges	
	2 = 15 to 20 AT
	3 = 20 to 25 AT
	4 = 25 to 30 AT
Ordering Example	
MS-215-7-2 describes MS-215-7 with 15 to 20 AT.	

MS-215-7



**MS-215-7**

Normally Closed Reed Sensor

Material Information

	Material	Colour
Housing	ABS	black
Cable	UL 1007/1569, AWG 24, 4 mm stripped and tinned	black
Potting compound	Epoxy	black

Test Procedure of final Reed Sensor

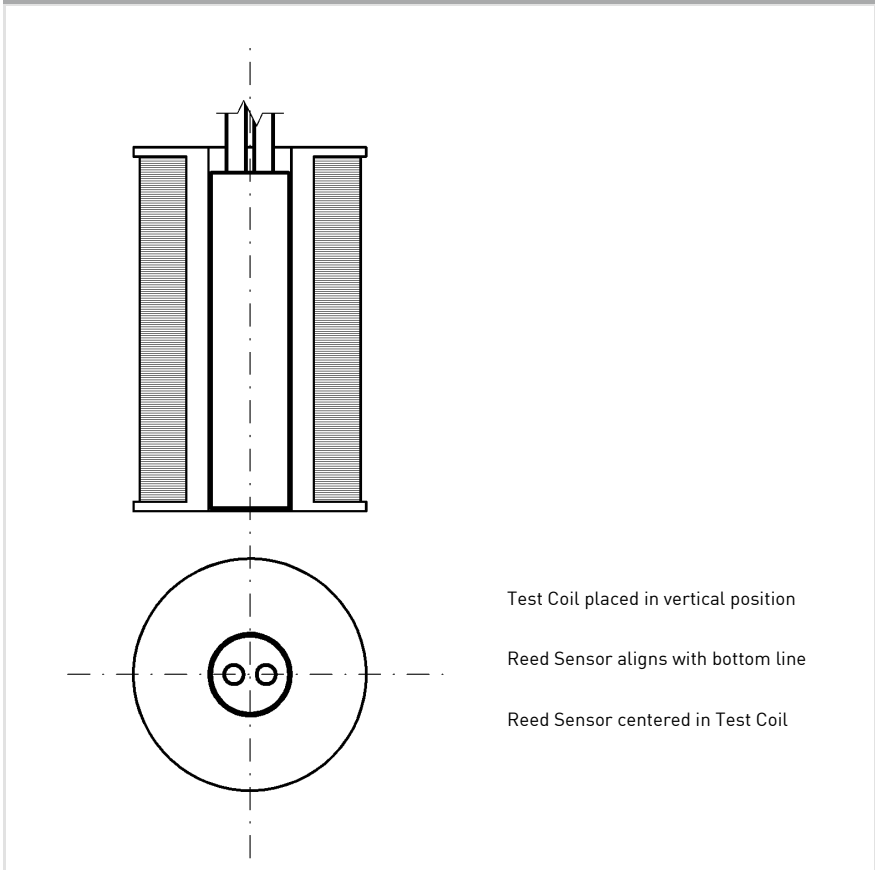

Test Parameters

Test coil	TC-093
Test programs	
AT range	Test program
2 =	MS-215-7-2
3 =	MS-215-7-3
4 =	MS-215-7-4

Remarks

When mounted onto ferromagnetic parts switching distance of MS-215-7 may reduce.  
Electromagnetical influences and magnetic fields may change the switching behaviour of the sensor.

Product image serves as example only.