

T1/E1 Clock Generator

Features

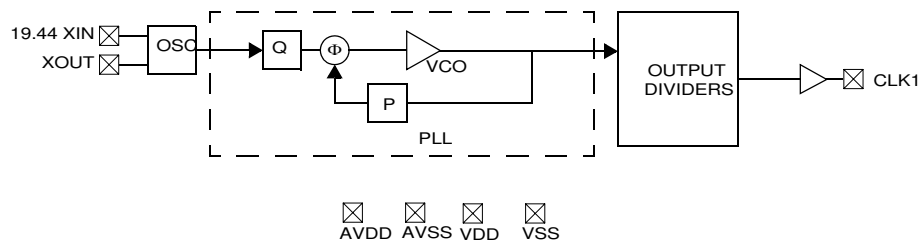
- Integrated phase-locked loop (PLL)
- Low-jitter, high-accuracy outputs
- 3.3V operation

Benefits

- High-performance PLL tailored for T1/E1 clock generation
- Meets critical timing requirements in complex system designs
- Enables application compatibility

Part Number	Outputs	Input Frequency Range	Output Frequencies
CY26200	1	19.44 MHz	1.544 MHz/2.048 MHz (selectable)

Logic Block Diagram



Pin Configuration

CY26200
8-pin SOIC

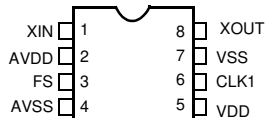


Table 1. CY26200 Frequency Select Option

Frequency Select	CLK1	Unit
0	1.544	MHz
1	2.048	MHz

Pin Summary

Pin Name	Pin Number	Pin Description
XIN	1	19.44-MHz Reference Input
AVDD	2	Analog Voltage Supply
FS	3	Frequency Select – see <i>Table 1</i>
AVSS	4	Analog Ground
VDD	5	Voltage Supply
CLK1	6	1.544-MHz/2.048-MHz Clock Output
VSS	7	Ground
XOUT ^[1]	8	Reference Output

Absolute Maximum Conditions

Parameter	Description	Min.	Max.	Unit
V _{DD}	Supply Voltage	-0.5	7.0	V
T _S	Storage Temperature ^[2]	-65	125	°C
T _J	Junction Temperature		125	°C
	Digital Inputs	V _{SS} - 0.3	V _{DD} + 0.3	V
	Digital Outputs Referred to V _{DD}	V _{SS} - 0.3	V _{DD} + 0.3	V
	Electrostatic Discharge	2000		V

Recommended Operating Conditions

Parameter	Description	Min.	Typ.	Max.	Unit
V _{DD} /AV _{DD}	Operating Voltage	3.135	3.3	3.465	V
T _A	Ambient Temperature (Commercial)	0		70	°C
T _A	Ambient Temperature (Industrial)	-40		+85	°C
C _{LOAD}	Max. Load Capacitance			15	pF
f _{REF}	Reference Frequency		19.44		MHz
t _{PU}	Power-up time for all V _{DD} s to reach minimum specified voltage (power ramps must be monotonic)	0.05		500	ms

DC Electrical Characteristics (Commercial)

Parameter	Description	Conditions	Min.	Typ.	Max.	Unit
I _{OH}	Output High Current	V _{OH} = V _{DD} - 0.5, V _{DD} = 3.3V	12	24		mA
I _{OL}	Output Low Current	V _{OL} = 0.5, V _{DD} = 3.3V	12	24		mA
C _{IN}	Input Capacitance				7	pF
I _{IZ}	Input Leakage Current			5		μA
I _{DD}	Supply Current	Sum of Core and Output Current			20	mA

DC Electrical Characteristics (Industrial)

Parameter	Description	Conditions	Min.	Typ.	Max.	Unit
I _{OH}	Output High Current	V _{OH} = V _{DD} - 0.5, V _{DD} = 3.3V	11	24		mA
I _{OL}	Output Low Current	V _{OL} = 0.5, V _{DD} = 3.3V	11	24		mA
C _{IN}	Input Capacitance				7	pF
I _{IZ}	Input Leakage Current			5		μA
I _{DD}	Supply Current	Sum of Core and Output Current			25	mA

Notes:

1. Float XOUT if XIN is externally driven
2. Rated for 10 years

AC Electrical Characteristics ($V_{DD} = 3.3V$, Commercial)

Parameter ^[3]	Description	Conditions	Min.	Typ.	Max.	Unit
DC	Output Duty Cycle	Duty Cycle is defined in <i>Figure 1</i> , 50% of V_{DD}	45	50	55	%
t_3	Rising Edge Slew Rate	Output Clock Rise Time, 20% - 80% of V_{DD}	0.8	1.4		V/ns
t_4	Falling Edge Slew Rate	Output Clock Fall Time, 80% - 20% of V_{DD}	0.8	1.4		V/ns
t_9	Clock Jitter	Peak to Peak period jitter		200		ps
t_{10}	PLL Lock Time				3	ms

AC Electrical Characteristics ($V_{DD} = 3.3V$, Industrial)

Parameter ^[3]	Name	Description	Min.	Typ.	Max.	Unit
DC	Output Duty Cycle	Duty Cycle is defined in <i>Figure 1</i> , 50% of V_{DD}	45	50	55	%
t_3	Rising Edge Slew Rate	Output Clock Rise Time, 20% - 80% of V_{DD}	0.8	1.4		V/ns
t_4	Falling Edge Slew Rate	Output Clock Fall Time, 80% - 20% of V_{DD}	0.8	1.4		V/ns
t_9	Clock Jitter	Peak to Peak period jitter		200		ps
t_{10}	PLL Lock Time				3	ms

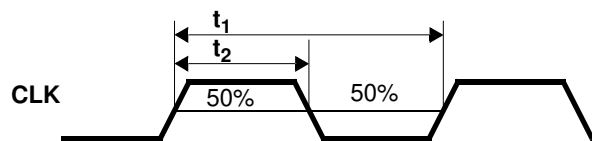
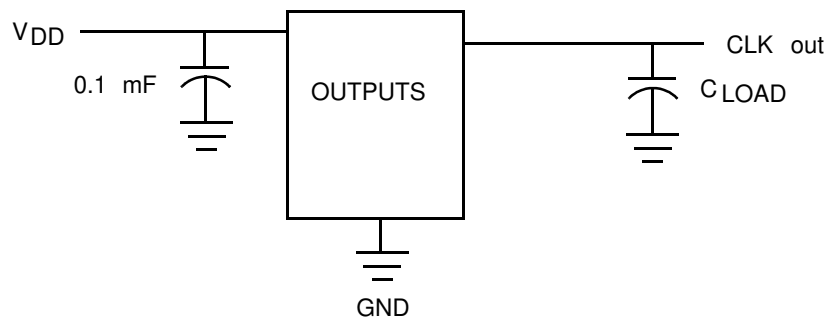
Test Circuit


Figure 1. Duty Cycle Definition; $DC = t_2/t_1$

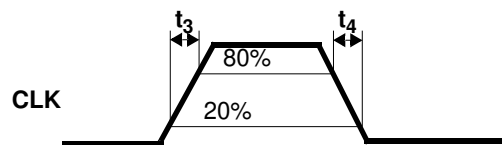


Figure 2. Rise and Fall Time Definitions

Ordering Information

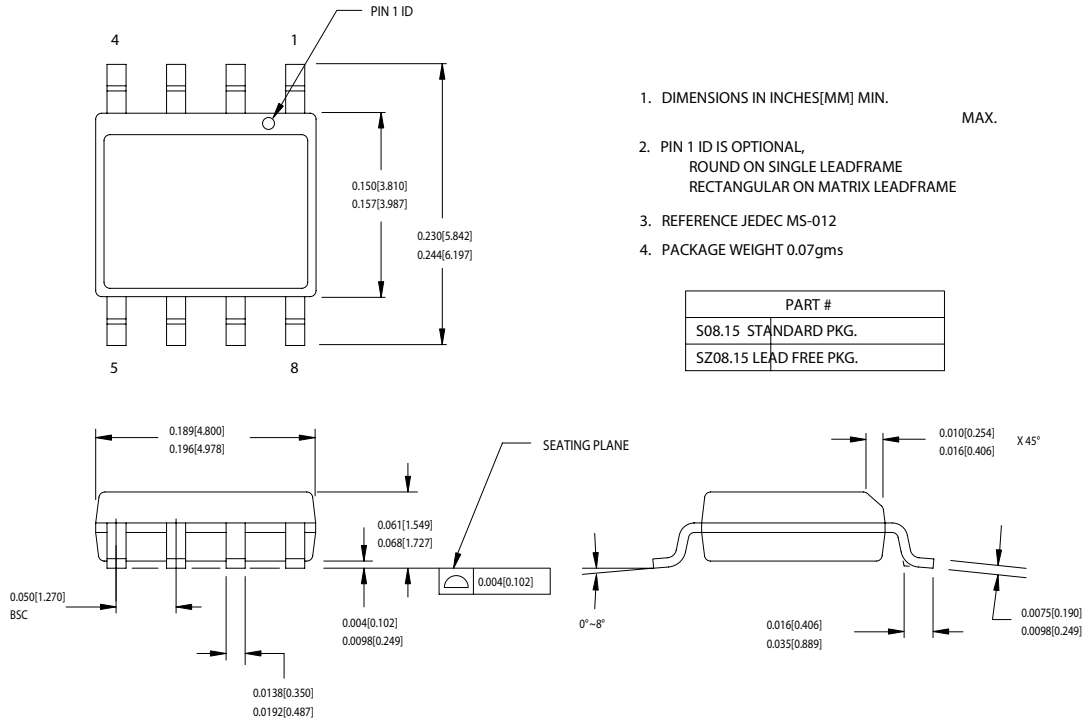
Ordering Code	Package Type	Operating Range	Operating Voltage
CY26200SC	8-lead SOIC	Commercial	3.3V
CY26200SCT	8-lead SOIC - Tape and Reel	Commercial	3.3V
CY26200SI	8-lead SOIC	Industrial	3.3V
CY26200SIT	8-lead SOIC - Tape and Reel	Industrial	3.3V
Lead-free			
CY26200SXC	8-lead SOIC	Commercial	3.3V
CY26200SXCT	8-lead SOIC - Tape and Reel	Commercial	3.3V
CY26200SXI	8-lead SOIC	Industrial	3.3V
CY26200SXIT	8-lead SOIC - Tape and Reel	Industrial	3.3V

Notes:

3. Not 100% tested

Package Diagram

8-lead (150-Mil) SOIC S8



1. DIMENSIONS IN INCHES[MM] MIN. MAX.
2. PIN 1 ID IS OPTIONAL, ROUND ON SINGLE LEADFRAME RECTANGULAR ON MATRIX LEADFRAME
3. REFERENCE JEDEC MS-012
4. PACKAGE WEIGHT 0.07gms

PART #
S08.15 STANDARD PKG.
SZ08.15 LEAD FREE PKG.

51-85066-°C

All product and company names mentioned in this document are the trademarks of their respective holders.

Document History Page

Document Title: CY26200 T1/E1 Clock Generator Document Number: 38-07335				
REV.	ECN No.	Issue Date	Orig. of Change	Description of Change
**	111745	05/06/02	CKN	New Data Sheet
*A	121890	12/14/02	RBI	Power up requirements added to Operating Conditions Information
*B	400148	See ECN	RGL	Added lead-free devices