

**Impact™  
Backplane  
Module Installation  
Press-In Tool**

**molex**

**Application Tooling  
Specification Sheet**

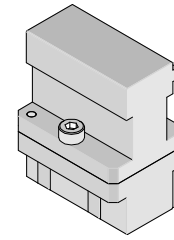

**Order No. 62201-8816**

**FEATURES**

- Polarized tool prevents product damage
- Tool provides uniform distribution of press force across entire pin array
- May be used as a stand-alone tool or mounted in an optional holder with other Molex press-in tools

**SCOPE**

**Products:** Impact™ 850Ω Vertical Backplane Signal Module Assembly, (3-Pair by 16 Column Assemblies). See Product List below for specific part numbers.

**Product List**

The following is a partial list of the product order numbers and their specifications this tool is designed to run. Updates to this list are available on [www.molex.com](http://www.molex.com).

Series No.	Guide Style	Columns	Assembly Order Number					
170522	Custom	16	170522-0007	170522-0008				
170525 850Ω	Open End	16	170525-1603	170525-1604	170525-1605	170525-1606	170525-1607	170525-1608
	Left End Wall		170525-1613	170525-1614	170525-1615	170525-1616	170525-1617	170525-1618
	Dual End Wall		170525-1623	170525-1624	170525-1625	170525-1626	170525-1627	170525-1628
	Right End Wall		170525-1633	170525-1634	170525-1635	170525-1636	170525-1637	170525-1638
	Left Guided	16	170525-3603	170525-3604	170525-3605	170525-3606	170525-3607	170525-3608
			170525-3613	170525-3614	170525-3615	170525-3616	170525-3617	170525-3618
			170525-3623	170525-3624	170525-3625	170525-3626	170525-3627	170525-3628
			170525-3633	170525-3634	170525-3635	170525-3636	170525-3637	170525-3638
			170525-3643	170525-3644	170525-3645	170525-3646	170525-3647	170525-3648
			170525-3653	170525-3654	170525-3655	170525-3656	170525-3657	170525-3658
			170525-3663	170525-3664	170525-3665	170525-3666	170525-3667	170525-3668
			170525-3673	170525-3674	170525-3675	170525-3676	170525-3677	170525-3678
	170525-3683	170525-3684	170525-3685	170525-3686	170525-3687	170525-3688		
	Left Guided End Wall	16	170525-7603	170525-7604	170525-7605	170525-7606	170525-7607	170525-7608
			170525-7613	170525-7614	170525-7615	170525-7616	170525-7617	170525-7618
			170525-7623	170525-7624	170525-7625	170525-7626	170525-7627	170525-7628
			170525-7633	170525-7634	170525-7635	170525-7636	170525-7637	170525-7638
			170525-7643	170525-7644	170525-7645	170525-7646	170525-7647	170525-7648
			170525-7653	170525-7654	170525-7655	170525-7656	170525-7657	170525-7658
			170525-7663	170525-7664	170525-7665	170525-7666	170525-7667	170525-7668
			170525-7673	170525-7674	170525-7675	170525-7676	170525-7677	170525-7678
	170525-7683	170525-7684	170525-7685	170525-7686	170525-7687	170525-7688		
	170525-7633	170525-7634	170525-7635	170525-7636	170525-7637	170525-7638		
	Right Guided	16	170525-5603	170525-5604	170525-5605	170525-5606	170525-5607	170525-5608
			170525-5613	170525-5614	170525-5615	170525-5616	170525-5617	170525-5618
			170525-5623	170525-5624	170525-5625	170525-5626	170525-5627	170525-5628
			170525-5633	170525-5634	170525-5635	170525-5636	170525-5637	170525-5638

Series No.	Guide Style	Columns	Assembly Order Number					
			170525 850Ω	Right Guided	16	170525-5643	170525-5644	170525-5645
170525-5653	170525-5654	170525-5655				170525-5656	170525-5657	170525-5658
170525-5663	170525-5664	170525-5665				170525-5666	170525-5667	170525-5668
170525-5673	170525-5674	170525-5675				170525-5676	170525-5677	170525-5678
170525-5683	170525-5684	170525-5685				170525-5686	170525-5687	170525-5688
170525-9603	170525-9604	170525-9605				170525-9606	170525-9607	170525-9608
170525-9613	170525-9614	170525-9615				170525-9616	170525-9617	170525-9618
170525-9623	170525-9624	170525-9625				170525-9626	170525-9627	170525-9628
170525-9633	170525-9634	170525-9635				170525-9636	170525-9637	170525-9638
170525-9643	170525-9644	170525-9645				170525-9646	170525-9647	170525-9648
170525-9653	170525-9654	170525-9655				170525-9656	170525-9657	170525-9658
170525-9663	170525-9664	170525-9665				170525-9666	170525-9667	170525-9668
170525-9673	170525-9674	170525-9675				170525-9676	170525-9677	170525-9678
170525-9683	170525-9684	170525-9685				170525-9686	170525-9687	170525-9688

### Tool Setup

Depending on the number of connectors to be installed and/or the press used, this tool can be used alone or with a group of press-in tools, mounted in a 62201-95XX rail (ordered separately). See Figure 1.

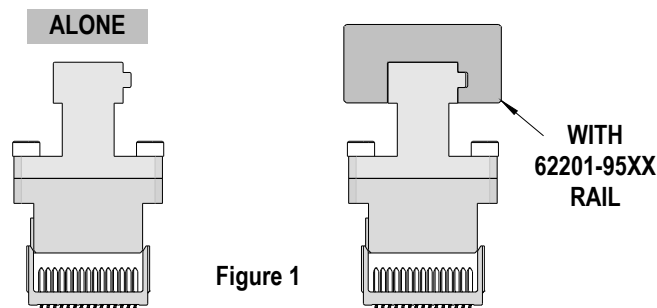

Figure 1

### Tool Installation

The 62201-95XX rail is available in a variety of lengths to accommodate multiple press-in tools.

Rail Part Number	Rail Overall Length
62201-9501	24mm (0.94 in)
62201-9502	72mm (2.83 in)
62201-9503	156mm (6.14 in)
62201-9504	216mm (8.50 in)
62201-9509	254mm (10.0 in)
62201-9511	305mm (12.0 in)

Reference: This Press-In Tool is 30.3mm (1.19 in.) long.

### Printed Circuit Board (PCB) Support

The Impact™ connectors require up to 3.6kg (8 lb) of force per pin to press into the PCB. To prevent excessive PCB flexure and/or damage to the PCB, a support plate is strongly recommended directly beneath the connector hole pattern.

Due to the custom nature of every application, Molex does not offer any PCB support plate. The customer must furnish their own support plate.

When creating the PCB support plate, remember to allow clearance for the connector pins as they pass through the PCB thickness.

## Press Equipment Recommendations

Many types of presses can be used to install Impact™ connectors, but to assure consistent connector installation Molex recommends the following press criteria:

1. The capability to detect force variations as low as 4.5kg (10 lb) during the press-in cycle; excessive force measurements should stop the press-in cycle.
2. The rate of pressing can be regulated as low as 0.13mm (0.005 in) per second.
3. Press stroke control to within 0.25mm (0.010 in).
4. Total press stroke must be at least 19mm (0.75 in).
5. For statistical purposes, automatic collection of force and distance data.

## Tool Operation

1. Insert by hand the backplane signal module assembly (s) carefully into the PCB hole pattern. Make sure the connector(s) are oriented properly by confirming the location of the #1 circuit notch with respect to the PCB layout.
2. Insert the Press-In Tool making sure that the notch in this tool is inserted into the slot on top of the connector housing of the backplane signal module assembly. See Figure 2.
3. Using the application tool and an appropriate press, seat the header assembly until there is less than 0.10mm (0.004 in) clearance between the bottom of the plastic housing and the surface of the PCB. See Figure 3.

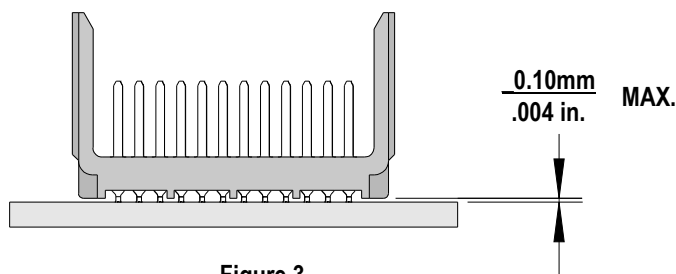
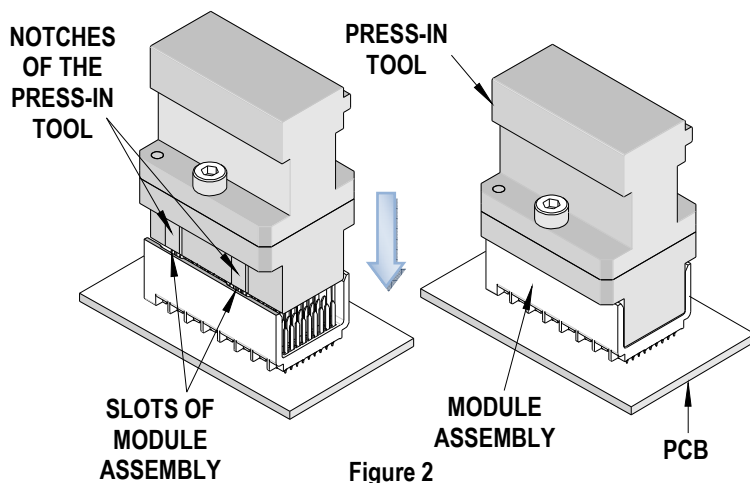

Figure 3

There should be no broken stand-offs along the perimeter of the part (an indication of over-pressing).

**CAUTION:** To prevent injury, never operate any press without the guards in place. Refer to the press manufacturer's instruction manual.

**CAUTION:** Molex application tooling specifications are valid only when used with Molex connectors and tooling.

## Contact Information

For more information on Molex application tooling please contact Molex at 1-800-786-6539.

Visit our Web site at <http://www.molex.com>