

DIMENSIONS(mm)			
SIZE	A	B	C
15	39.50	25.00	16.30
26	48.00	33.30	24.60
44	61.50	47.05	38.40
62	77.80	63.50	54.80

**NOTE:**

**MATERIAL**

HOUSING	PBT UL94V-0, BLACK
FLANGE	PBT UL94V-0, BLACK
CONTACT	BRASS, PLATING P/N KEY BELOW
SHELL	STEEL, NICKEL
O-RING	SILICONE
SEALING COMPOUND	EPOXY
HARDWARE	BRASS; NICKEL PLATED

**HARDWARE OPTIONS**

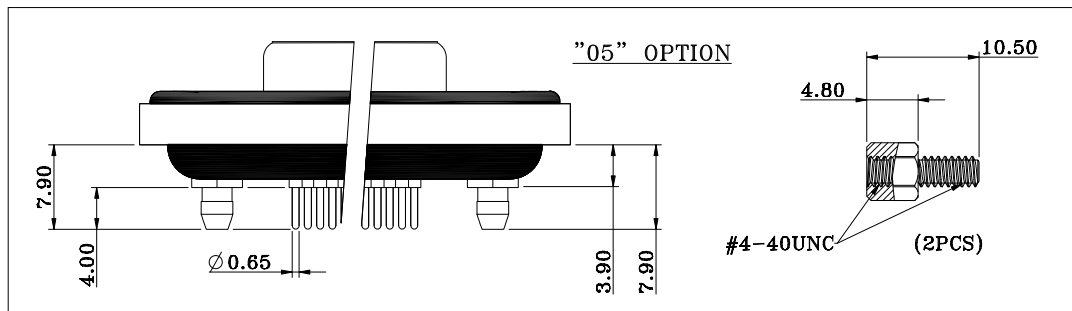
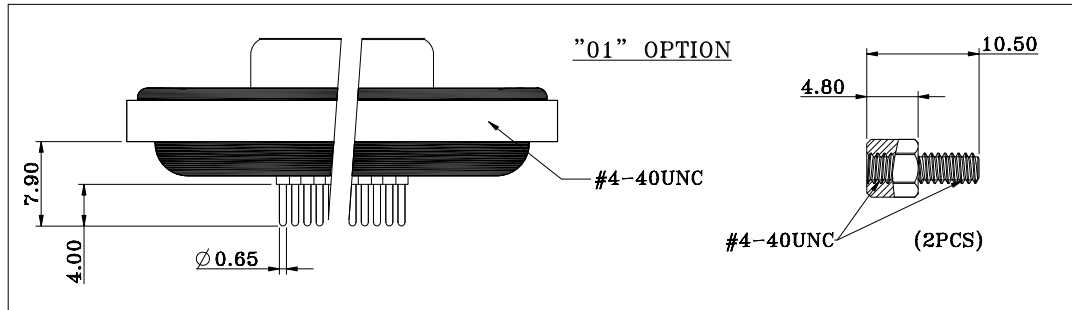

**ELECTRICAL**

RATED CURRENT	3A
VOLTAGE	1000 VAC 1 MIN
INSULATOR RESISTANCE	5 GOhms MIN.
CONTACT RESISTANCE	10 mOhms MAX.
WATER PROOF	IP67
ENVIRONMENT	
OPERATION TEMPERATURE	-25°C TO +85°C

**HDF-VYY-213LYYY**

**SERIES**

HDF = HD DSUB FLANGE

**CONTACT TYPE**

V = VERTICLE PCB MOUNT

**POSITIONS**

15  
26  
44  
62

**GENDER**

2 = FEMALE

**HARDWARE OPTIONS**

01 = 4-40 THREADED INSERTS/4-40 JACKSCREWS

05 = 4-40 THREADED BOARDLOCKS/4-40 JACKSCREWS

**CONTACT PLATING OPTIONS**

1 = GOLD FLASH

2 = 30u" GOLD PLATING

**RoHS COMPLIANT**



THESE DRAWINGS AND SPECIFICATIONS ARE THE PROPERTY OF NorComp AND SHALL NOT BE REPRODUCED, COPIED OR USED AS THE BASIS FOR THE MANUFACTURE OR SALE OF APPARATUS WITHOUT WRITTEN PERMISSION.

DRAWN:

J. KADEL

DATE:

03/02/2020

**TOLERANCES**

X.	±0.40
.X	±0.30
.XX	±0.20
.XXX	±0.10

UNITS = mm

**DO NOT SCALE FROM DRAWING**

**NorComp**

SCALE:

NTS

SHEET

OF

REV

DWG NO.

HDF-VYY-213LYYY

**\*\*ø3.20MM HOLES NOT NEEDED FOR "01" HARDWARE OPTION**

15 POSITION

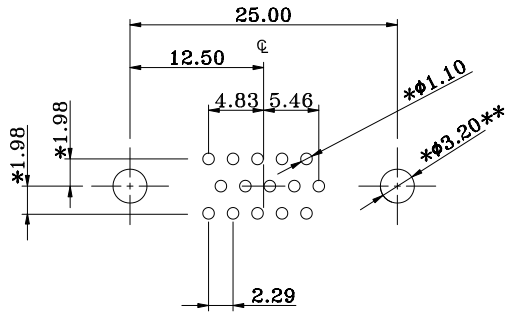

26 POSITION

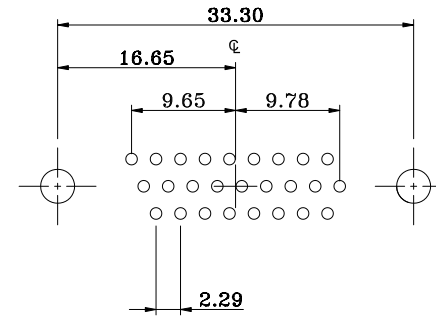

44 POSITION

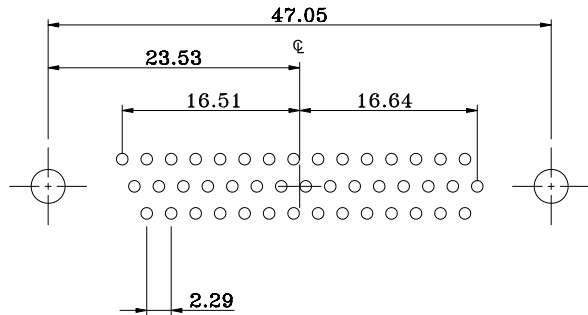

62 POSITION

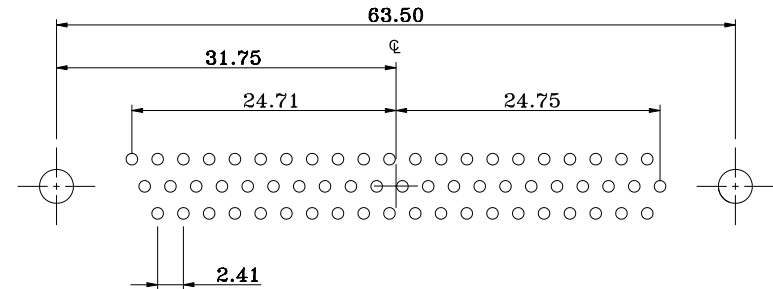

RECOMMENDED PCB LAYOUT

\*TYPICAL // HOLE SIZE MAY NOT BE SUITABLE FOR YOUR SPECIFIC APPLICATION

RoHS COMPLIANT



THESE DRAWINGS AND SPECIFICATIONS ARE THE PROPERTY OF NorComp AND SHALL NOT BE REPRODUCED, COPIED OR USED AS THE BASIS FOR THE MANUFACTURE OR SALE OF APPARATUS WITHOUT WRITTEN PERMISSION.

DRAWN:

J. KADEL

DATE:

03/02/2020

TOLERANCES

X. ±0.40  
 .X ±0.30  
 .XX ±0.20  
 .XXX ±0.10

UNITS = mm

DO NOT SCALE FROM DRAWING

NorComp

SCALE: NTS

SHEET 2 OF 2

REV 3

DWG NO.

HDF-VYY-213LYYY