

SPECIFICATION FOR DYNAMIC SPEAKER

Customer	
Customer P/N	
BeStar Model Name	BLS50-1-08H18.2B-03 LF
Product No.	120331
Issue No.	BS/TES01.938C
Issue Date	08/06/20

Approval:

1. Technical Terms
2. Frequency Response
3. Drawing
4. Reliability Test
5. Packing
6. History change record

Drawn by	Checked by	Approved by	Customer approved
汪风声	王文邦	程久生	

For conform to the European Union Directive on the Restriction of Hazardous Substances(RoHS), this type of productions forbid use all the hazardous substances as follow:

Lead
Cadmium
Mercury
Hexavalent chromium
Polybrominated biphenyls (PBB)
Polybrominated diphenyl ethers (PBDE)



BESTAR ELECTRONICS INDUSTRY CO.,LTD
 No.199 HuangHe West Road.New district, changzhou,
 jiangsu Province,P.R.China
 Tel:86-519-88222567 Fax:86-519-88222551
 Http:www.be-star.com
 E-mail: wu@be-star.com, info@be-star.com

BLS50-1-08H18.2B-03 LF



1. Technical Terms

No.	Item	Specifications
1.	Size	Ø 50*18.2mm
2.	Impedance at 1KHz	8 ±1.2 Ω
3.	Resonance frequency	300 ± 45Hz
4.	Operating frequency range	fo...10K Hz
5.	Rated input power	1w
6.	Maximum input power	2w
7.	Buzz & Rattle(at sine wave 2.83V)	must be normal
8.	T.H.D(at 1KHz/0.1W)	<2 %
9.	SPL(1W,1M) at 1.0K Hz	81 ± 3dB
10.	Connection terminals	Solder tags(acc.DIN46244)
		dimension 2.8*0.5mm
11.	Operating temperature	-40...+85 °C
12.	Storage temperature	-40...+ 85 °C

2. Frequency Response

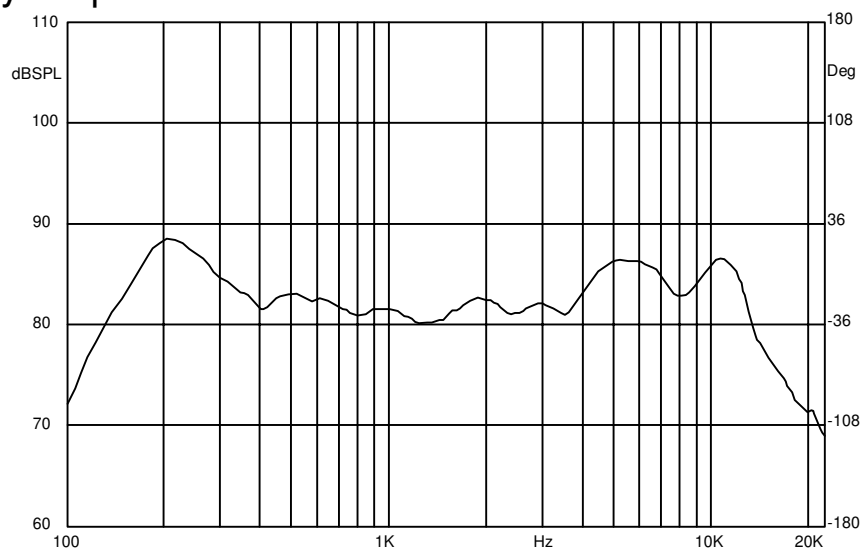

This print and information there in are proprietary to Bestar Electronics Industry Co., Ltd. and shall not be used in whole or in part without its written content

C	08.06.20	汪凤声		Date:	08.06.20	BLS50-1-08H18.2B-03 LF	
B	08.05.08	汪凤声		Drawn by:	汪凤声		
A	08.04.11	王平		Checked by:	王文邦	Speaker	
Rev.	Date	Drawn	Note	Approved by:	程久生		
BESTAR ELECTRONICS INDUSTRY CO.,LTD						DRG NO: BS/TES01.938C	Page:1 of 5
www.be-star.com wu@be-star.com							

BLS50-1-08H18.2B-03 LF

3.Drawing

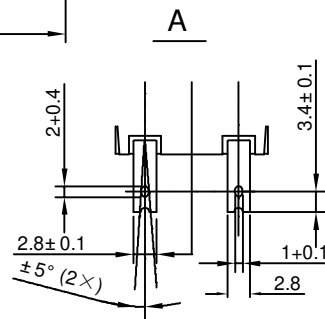
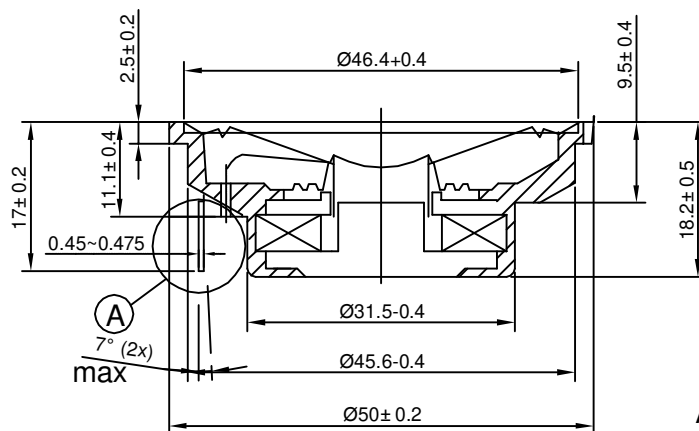
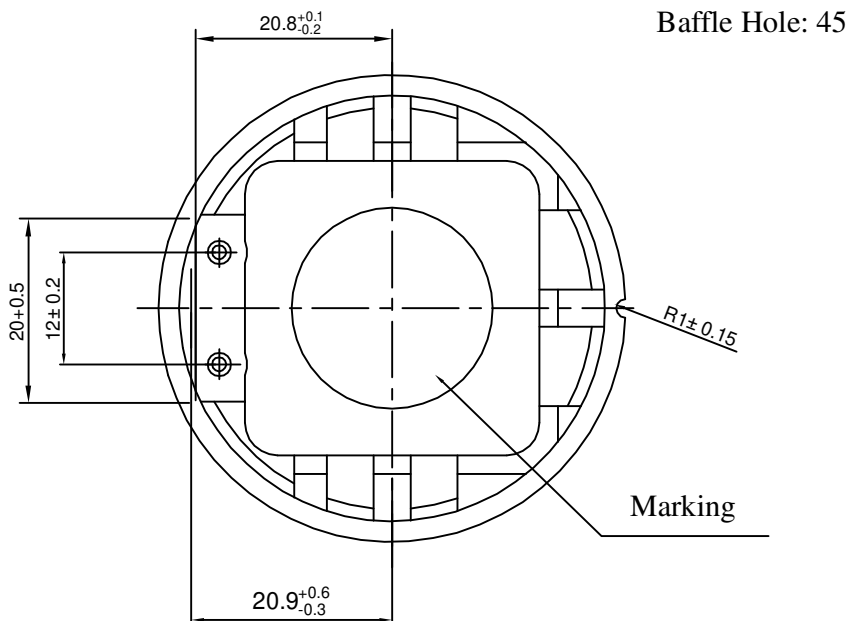

This print and information there in are proprietary to Bestar Electronics Industry Co., Ltd. and shall not be used in whole or in part without its written content

C	08.06.20	汪风声		Date:	08.06.20	BLS50-1-08H18.2B-03 LF	
B	08.05.08	汪风声		Drawn by:	汪风声		
A	08.04.11	王平		Checked by:	王文邦	Speaker	
REV.	Date	Drawn	Note	Approved by:	程久生		
BESTAR ELECTRONICS INDUSTRY CO.,LTD						DRG NO: BS/TES01.938C	Page:2 of 5
www.be-star.com wu@be-star.com							

BLS50-1-08H18.2B-03 LF

4. Reliability Test

1. Load test
 - Duration 96hrs
 - 1W.white noise,temperature cycle -40...+85 ° C.with cycle duration
2. High temperature durability acc. to IEC 60068 part2-2
 - Temperature +85 ± 3° C
 - Duration 1000h
3. Low temperature durability acc. to IEC 60068 part 2-1
 - Temperature -40 ± 3° C
 - Duration 500h
4. Humidity durability acc.to IEC 60068 part2-3
 - Temperture 40 ± 3° C
 - Rel.humidity 93 %RH
 - Duration 56days
5. Temperature cycle durability acc.to IEC60068 part2-14
 - Low Temperature -40 ± 3° C
 - Upper Temperature +85 ± 3° C
 - Transfer time from lower to upper temperature <10s
 - Number of cycles 100cycles
6. Shock test acc. to IEC 60068 part2-27
 - 100g for each free mutually perpendicular directions to each of 3times by sine-wave
7. Vibration test acc. to IEC 60068 part 2 -6
 - sine-wave excitation; 8...300Hz,2g,1 octave/min; test time 16h each axis
 - Additional requirements:
 - Test of solderability and resistance to soldering heat acc. to VDON4.3643.001
 - X-ray solderpoint inspection according to VDON 4.4814.001
 - Washability:not washable
 - Cadmium prohibited as per DIN 5.5000.1

After the test,all electronic and acoustic characteristic should be satisfied with the specification. SPL: Deviation is of ± 2dB of initial value.

This print and information there in are proprietary to Bestar Electronics Industry Co., Ltd. and shall not be used in whole or in part without its written consent

C	08.06.20	汪凤声		Date:	08.06.20	BLS50-1-08H18.2B-03 LF	
B	08.05.08	汪凤声		Drawn by:	汪凤声		
A	08.04.11	王平		Checked by:	王文邦	Speaker	
REV.	Date	Drawn	Note	Approved by:	程久生		
BESTAR ELECTRONICS INDUSTRY CO.,LTD						DRG NO: BS/TES01.938C	Page:3 of 5
www.be-star.com wu@be-star.com							

BLS50-1-08H18.2B-03 LF

5. Packing

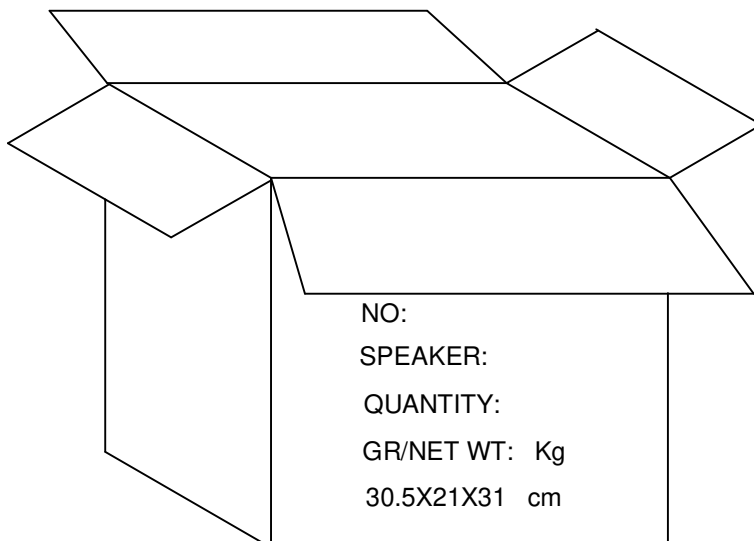
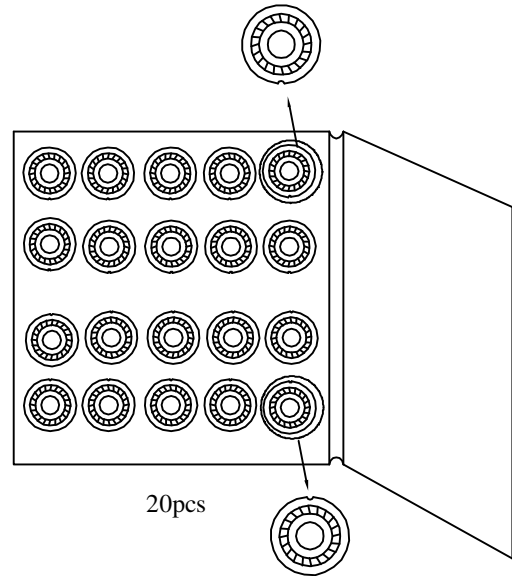
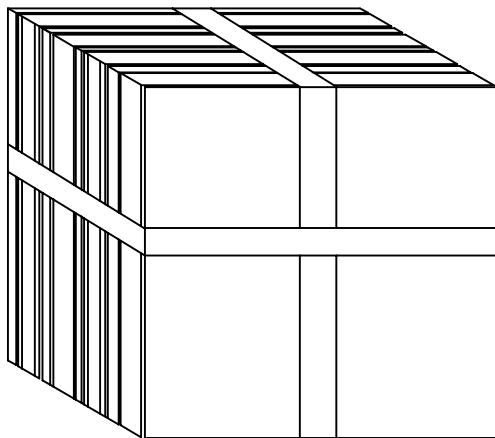

Remark:
7pcs cardboard per carton,
140pcs per carton,
1pc cardboard 1pc clapboard,
2pcs covers percarton.

This print and information there in are proprietary to Bestar Electronics Industry Co., Ltd. and shall not be used in whole or in part without its written content.

C	08.06.20	汪风声		Date:	08.06.20	BLS50-1-08H18.2B-03 LF	
B	08.05.08	汪风声		Drawn by:	汪风声		
A	08.04.11	王平		Checked by:	王文邦	Speaker	
REV.	Date	Drawn	Note	Approved by:	程久生		
BESTAR ELECTRONICS INDUSTRY CO.,LTD						DRG NO: BS/TES01.938C	Page:4 of 5

