

# VAL-MS 1500DC-PV/2+V - Type 2 surge arrester



1033708

<https://www.phoenixcontact.com/us/products/1033708>

Please be informed that the data shown in this PDF document is generated from our online catalog. Please find the complete data in the user documentation. Our general terms of use for downloads are valid.



Surge protective device for 2-pos. isolated and grounded 1500 V DC PV systems, for DIN rail mounting, 3-pos. base element, three pluggable temperature-monitored protective elements, status message on each plug.

## Your advantages

- Quality proven millions of times over in the widest range of applications
- Rapid installation with bridges, thanks to industry-standard overall width of 1 HP
- Easy testing and insulation measurement, thanks to pluggable protection modules
- Wide range of applications due to various nominal voltages
- High degree of modularity provides individual solutions for every application

## Commercial data

Item number	1033708
Packing unit	1 pc
Minimum order quantity	1 pc
Sales key	CL01
Product key	CL1324
Catalog page	Page 73 (C-4-2019)
GTIN	4055626540351
Weight per piece (including packing)	351.1 g
Weight per piece (excluding packing)	335.3 g
Customs tariff number	85354000
Country of origin	DE

# VAL-MS 1500DC-PV/2+V - Type 2 surge arrester



1033708

<https://www.phoenixcontact.com/us/products/1033708>

## Technical data

### Notes

#### General

Note	The device is intended for touch proof installation in a housing. Ensure that there is a gap of at least 8 mm between the active and grounded parts in the connection area.
------	---

### Product properties

IEC test classification	PV II
	PV T2
EN type	T2
IEC power supply system	DC
Type	DIN rail module, two-section, divisible
Distance between live and grounded parts	8 mm
Product type	PV arrester
Product family	VALVETRAB MS
Installation location	Interior
Installation location of the disconnect device	Internal
Accessibility	Accessible
Connection configuration	Y configuration
SPD failure behavior	OCFM (Open-Circuit Failure Mode)
Surge protection fault message	optical

#### Insulation characteristics

Overvoltage category	III
Pollution degree	2

### Connection data

Connection method	Screw connection
Screw thread	M5
Tightening torque	3 Nm (1.5 mm <sup>2</sup> ... 16 mm <sup>2</sup> )
	4.5 Nm (25 mm <sup>2</sup> ... 35 mm <sup>2</sup> )
Stripping length	16 mm
Conductor cross section flexible	1.5 mm <sup>2</sup> ... 25 mm <sup>2</sup>
Conductor cross section rigid	1.5 mm <sup>2</sup> ... 35 mm <sup>2</sup>
Conductor cross section AWG	15 ... 2
Connection method	Fork-type cable lug
Conductor cross section flexible	1.5 mm <sup>2</sup> ... 16 mm <sup>2</sup>

### Dimensions

# VAL-MS 1500DC-PV/2+V - Type 2 surge arrester



1033708

<https://www.phoenixcontact.com/us/products/1033708>

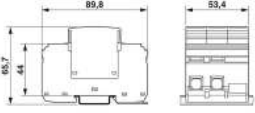
Dimensional drawing	
Width	53.4 mm
Height	89.8 mm
Depth	65.7 mm
Horizontal pitch	3 Div.

## Material specifications

Flammability rating according to UL 94	V-0
CTI value of material	600
Insulating material	PA 6.6-FR PBT-FR
Material group	I
Housing material	PA 6.6-FR PBT-FR

## Mechanical properties

### Mechanical data

Open side panel	No
-----------------	----

## Protective circuit

Mode of protection	(L+) - (L-) (L+) - PE (L-) - PE
Direction of action	(L+)-PE & (L-)-PE & (L+)-(L-)
Rated load current $I_L$	80 A
Residual current $I_{PE}$	$\leq 350 \mu\text{A DC}$ $\leq 600 \mu\text{A AC}$
Standby power consumption $P_C$	$\leq 250 \text{ mVA}$
Nominal discharge current $I_n$ (8/20) $\mu\text{s}$	15 kA
Maximum discharge current $I_{max}$ (8/20) $\mu\text{s}$	30 kA
Total discharge current $I_{total}$ (8/20) $\mu\text{s}$	30 kA
Voltage protection level $U_p$	$\leq 5 \text{ kV}$
Residual voltage $U_{res}$	$\leq 3.8 \text{ kV (at 3 kA)}$ $\leq 4.1 \text{ kV (at 5 kA)}$ $\leq 4.4 \text{ kV (at 10 kA)}$ $\leq 5 \text{ kV (at 15 kA)}$ $\leq 5.3 \text{ kV (at 20 kA)}$ $\leq 5.7 \text{ kV (at 30 kA)}$ $\leq 6 \text{ kV (at 40 kA)}$
Response time $t_A$	$\leq 25 \text{ ns}$

# VAL-MS 1500DC-PV/2+V - Type 2 surge arrester



1033708

<https://www.phoenixcontact.com/us/products/1033708>

## PV protective circuit

Connection configuration	Y configuration
SPD failure behavior	OCFM (Open-Circuit Failure Mode)

## Protective circuit DC voltage side (DC)

Open circuit voltage $U_{OCSTC}$	$\leq 1250$ V DC
Maximum discharge current $I_{max}$ (8/20) $\mu s$	30 kA
Response time $t_A$	$\leq 25$ ns
Total discharge current $I_{total}$ (8/20) $\mu s$	30 kA
Nominal discharge current $I_n$ (8/20) $\mu s$	15 kA
Rated load current $I_L$	80 A
Continuous operating current $I_{CPV}$	$< 350$ $\mu A$
Maximum continuous operating voltage $U_{CPV}$	1500 V DC
Short-circuit current rating $I_{SCPV}$	2000 A
Residual voltage $U_{res}$	$\leq 3.8$ kV (at 3 kA)
	$\leq 4.1$ kV (at 5 kA)
	$\leq 4.4$ kV (at 10 kA)
	$\leq 5$ kV (at 15 kA)
	$\leq 5.3$ kV (at 20 kA)
	$\leq 5.7$ kV (at 30 kA)
	$\leq 6$ kV (at 40 kA)
Residual current $I_{PE}$	$\leq 350$ $\mu A$ DC
	$\leq 600$ $\mu A$ AC
Voltage protection level $U_p$	$\leq 5$ kV
Standby power consumption $P_C$	$\leq 250$ mVA

## Additional technical data

Maximum discharge current $I_{max}$ (8/20) $\mu s$	40 kA
Nominal discharge current $I_n$ (8/20) $\mu s$	20 kA (4x (5x $I_n$   120 s)   30 min))

## Environmental and real-life conditions

### Ambient conditions

Degree of protection	IP20 (only when all terminal points are used)
Ambient temperature (operation)	-40 °C ... 85 °C
Ambient temperature (storage/transport)	-40 °C ... 85 °C
Altitude	$\leq 3000$ m (amsl)
Permissible humidity (operation)	5 % ... 95 %
Shock (operation)	30g (Half-sine / 11 ms / 3x $\pm X$ , $\pm Y$ , $\pm Z$ )
Vibration (operation)	5g (5-500 Hz/2.5 h/XYZ)

## Approvals

### UL specifications

Maximum continuous operating voltage MCOV	1500 V DC
Short-circuit current rating (SCCR)	50 kA

# VAL-MS 1500DC-PV/2+V - Type 2 surge arrester



1033708

<https://www.phoenixcontact.com/us/products/1033708>

Voltage protection rating VPR	4 kV
Nominal discharge current $I_n$	10 kA
Mode of protection	(DC+) - (DC-)
	(DC+) - G
	(DC-) - G
Nominal voltage	1500 V DC
Power distribution system	DC PV
SPD Type	1CA

## UL connection data

Tightening torque	30 lb <sub>f</sub> -in.
Conductor cross section AWG	14 ... 2

## Standards and regulations

Standards/specifications	EN 61643-31
Note	2019
Standards/specifications	IEC 61643-31
Note	2018

## Mounting

Mounting type	DIN rail: 35 mm
---------------	-----------------

# VAL-MS 1500DC-PV/2+V - Type 2 surge arrester

1033708

<https://www.phoenixcontact.com/us/products/1033708>

## Drawings

Dimensional drawing

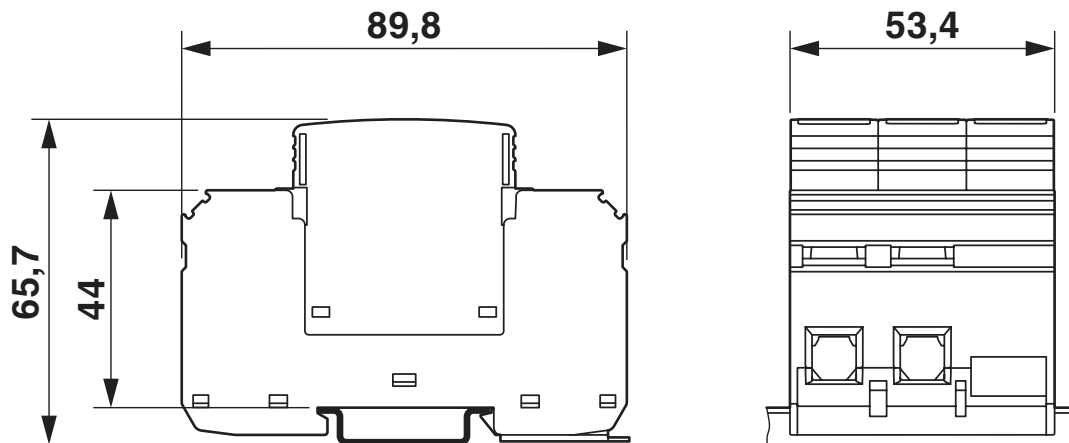

Circuit diagram

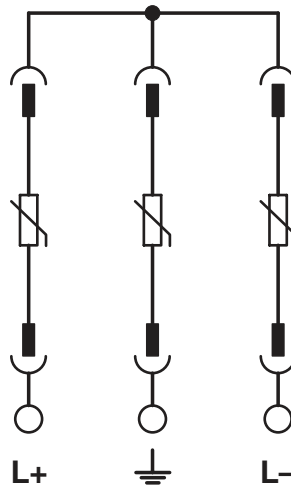

# VAL-MS 1500DC-PV/2+V - Type 2 surge arrester



1033708

<https://www.phoenixcontact.com/us/products/1033708>

## Approvals

To download certificates, visit the product detail page: <https://www.phoenixcontact.com/us/products/1033708>



**cUL Recognized**

Approval ID: FILE E 330181



**UL Recognized**

Approval ID: FILE E 330181

**CCA**

Approval ID: NTR-NL 7937



**KEMA-KEUR**

Approval ID: 71-123544 REV.2



**IECEE CB Scheme**

Approval ID: NL-81006/A1

**UAE-RoHS**

Approval ID: 22-09-51250

**cULus Recognized**

# VAL-MS 1500DC-PV/2+V - Type 2 surge arrester



1033708

<https://www.phoenixcontact.com/us/products/1033708>

## Classifications

### ECLASS

ECLASS-11.0	27130805
ECLASS-13.0	27171402

### ETIM

ETIM 8.0	EC000941
----------	----------

### UNSPSC

UNSPSC 21.0	39121620
-------------	----------



# VAL-MS 1500DC-PV/2+V - Type 2 surge arrester



1033708

<https://www.phoenixcontact.com/us/products/1033708>

## Environmental product compliance

China RoHS	Environmentally friendly use period: unlimited = EFUP-e
	No hazardous substances above threshold values

# VAL-MS 1500DC-PV/2+V - Type 2 surge arrester



1033708

<https://www.phoenixcontact.com/us/products/1033708>

## Accessories

### ZBN 18,LGS:ERDE - Marker for terminal blocks

2749589

<https://www.phoenixcontact.com/us/products/2749589>



Marker for terminal blocks, Strip, white, labeled, horizontal: Grounding symbol, mounting type: snapped, for terminal block width: 18 mm, lettering field size: 18 x 5 mm, Number of individual labels: 5

---

### ZBN 18,LGS:L1-N,ERDE - Marker for terminal blocks

2749576

<https://www.phoenixcontact.com/us/products/2749576>



Marker for terminal blocks, Strip, white, labeled, horizontal: L1, L2, L3, N, GND, mounting type: snapped, for terminal block width: 18 mm, lettering field size: 18 x 5 mm, Number of individual labels: 5

# VAL-MS 1500DC-PV/2+V - Type 2 surge arrester

1033708

<https://www.phoenixcontact.com/us/products/1033708>



## ZBN 18:UNBEDRUCKT - Zack marker strip

2809128

<https://www.phoenixcontact.com/us/products/2809128>



Zack marker strip, Strip, white, unlabeled, can be labeled with: CMS-P1-PLOTTER, PLOTMARK, mounting type: snapped, for terminal block width: 18 mm, lettering field size: 18 x 5 mm, Number of individual labels: 5

---

## B-STIFT - Marker pen

1051993

<https://www.phoenixcontact.com/us/products/1051993>



Marker pen, for manual labeling of unprinted Zack strips, smear-proof and waterproof, line thickness 0.5 mm

# VAL-MS 1500DC-PV/2+V - Type 2 surge arrester



1033708

<https://www.phoenixcontact.com/us/products/1033708>

## ATP-QTTCB - Partition plate

3206238

<https://www.phoenixcontact.com/us/products/3206238>

Partition plate, length: 102 mm, width: 2 mm, height: 102 mm, color: gray



## VAL-MS 1500DC-PV-ST - Type 2 surge protection plug

1033727

<https://www.phoenixcontact.com/us/products/1033727>



Pack of three replacement plugs for PV arrester combinations from the VAL-MS 1500DC-PV-... product range

Phoenix Contact 2023 © - all rights reserved  
<https://www.phoenixcontact.com>

Phoenix Contact USA  
586 Fulling Mill Road  
Middletown, PA 17057, United States  
(+717) 944-1300  
[info@phoenixcon.com](mailto:info@phoenixcon.com)