

### FEATURES

Infinite Sample-and-Hold Capability to  $\pm 0.018\%$  Accuracy  
High Integration:

32-Channel DAC in 12 mm  $\times$  12 mm CSPBGA

Per Channel Acquisition Time of 16  $\mu$ s Max

Adjustable Voltage Output Range

Output Impedance 0.5  $\Omega$

Output Voltage Span 10 V

Readback Capability

DSP/Microcontroller Compatible Serial Interface

Parallel Interface

Temperature Range  $-40^{\circ}\text{C}$  to  $+85^{\circ}\text{C}$

### APPLICATIONS

Optical Networks

Automatic Test Equipment

Level Setting

Instrumentation

Industrial Control Systems

Data Acquisition

Low Cost I/O

### GENERAL DESCRIPTION

The AD5533 combines a 32-channel voltage translation function with an infinite output hold capability. An analog input voltage on the common input pin,  $V_{IN}$ , is sampled and its digital representation transferred to a chosen DAC Register.  $V_{OUT}$  for this DAC is then updated to reflect the new contents of the DAC register. Channel selection is accomplished via the parallel address inputs A0–A4 or via the serial input port. The output voltage range is determined by the offset voltage at the OFFS\_IN pin and the gain of the output amplifier. It is restricted to a range from  $V_{SS} + 2$  V to  $V_{DD} - 2$  V because of the headroom of the output amplifier.

The device is operated with  $AV_{CC} = +5$  V  $\pm$  5%,  $DV_{CC} = +2.7$  V to  $+5.25$  V,  $V_{SS} = -4.75$  V to  $-16.5$  V, and  $V_{DD} = +8$  V to  $+16.5$  V and requires a stable 3 V reference on REF\_IN as well as an offset voltage on OFFS\_IN.

### PRODUCT HIGHLIGHTS

1. Infinite Droopless Sample-and-Hold Capability.
2. The AD5533 is available in a 74-lead CSPBGA with a body size of 12 mm  $\times$  12 mm.

### FUNCTIONAL BLOCK DIAGRAM

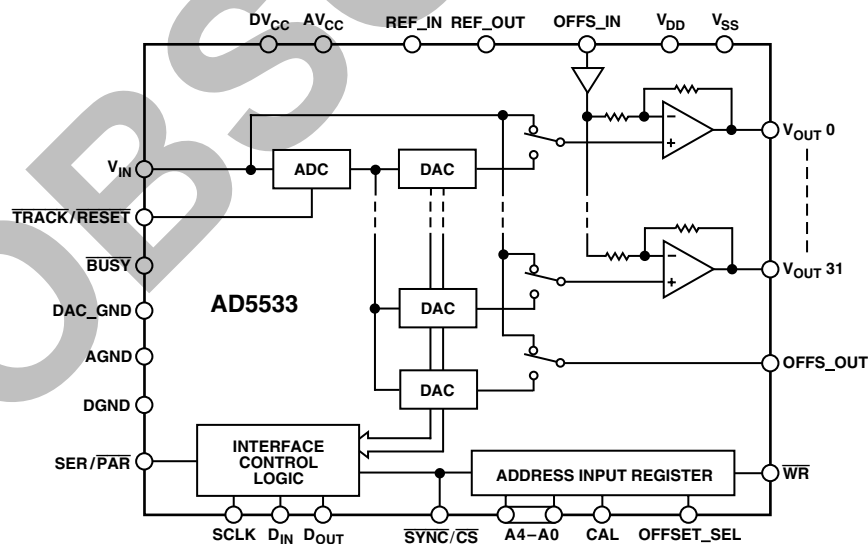

\*Protected by U.S. Patent No. 5,969,657.

REV. A

Information furnished by Analog Devices is believed to be accurate and reliable. However, no responsibility is assumed by Analog Devices for its use, nor for any infringements of patents or other rights of third parties that may result from its use. No license is granted by implication or otherwise under any patent or patent rights of Analog Devices. Trademarks and registered trademarks are the property of their respective companies.

One Technology Way, P.O. Box 9106, Norwood, MA 02062-9106, U.S.A.  
Tel: 781/329-4700 [www.analog.com](http://www.analog.com)  
Fax: 781/326-8703 © 2003 Analog Devices, Inc. All rights reserved.

# AD5533—SPECIFICATIONS

( $V_{DD} = +8\text{ V to }+16.5\text{ V}$ ,  $V_{SS} = -4.75\text{ V to }-16.5\text{ V}$ ;  $AV_{CC} = +4.75\text{ V to }+5.25\text{ V}$ ;  $DV_{CC} = 2.7\text{ V to }5.25\text{ V}$ ;  $AGND = DGND = DAC\_GND = 0\text{ V}$ ;  $REF\_IN = 3\text{ V}$ ; Output Range from  $V_{SS} + 2\text{ V to }V_{DD} - 2\text{ V}$ . All outputs unloaded. All specifications  $T_{MIN}$  to  $T_{MAX}$ , unless otherwise noted.)

Parameter <sup>1</sup>	A Version <sup>2</sup>	Unit	Conditions/Comments
ANALOG CHANNEL $V_{IN}$ to $V_{OUT}$ Nonlinearity	$\pm 0.018$ $\pm 0.006$	% max % typ	Input Range 100 mV to 2.96 V. After Gain and Offset Adjustment. 3.52 typ.
Gain Offset Error	3.46/3.6 $\pm 50$	min/max mV max	
ANALOG INPUT ( $V_{IN}$ ) Input Voltage Range Input Lower Dead Band	0–3 70	V mV max	Nominal Input Range. 50 mV typ. Referred to $V_{IN}$ . See Figure 5. 12 mV typ. Referred to $V_{IN}$ . See Figure 5. 100 nA typ. $V_{IN}$ Being Acquired on One Channel.
Input Upper Dead Band	40	mV max	
Input Current Input Capacitance <sup>3</sup>	1 20	$\mu\text{A}$ max pF typ	
ANALOG INPUT (OFFS_IN) Input Current Input Voltage Range	1 0/4	$\mu\text{A}$ max V min/max	100 nA typ. Output Range Restricted from $V_{SS} + 2\text{ V to }V_{DD} - 2\text{ V}$ .
VOLTAGE REFERENCE REF_IN Nominal Input Voltage Input Voltage Range <sup>3</sup> Input Current	3.0 2.85/3.15 1	V V min/max $\mu\text{A}$ max	<1 nA typ.
REF_OUT Output Voltage Output Impedance <sup>3</sup> Reference Temperature Coefficient <sup>3</sup>	3 280 60	V typ k $\Omega$ typ ppm/ $^{\circ}\text{C}$ typ	
ANALOG OUTPUTS ( $V_{OUT}$ 0–31) Output Temperature Coefficient <sup>3, 4</sup> DC Output Impedance Output Range Resistive Load <sup>3, 5</sup> Capacitive Load <sup>3, 5</sup> Short-Circuit Current <sup>3</sup> DC Power Supply Rejection Ratio <sup>3</sup> DC Crosstalk <sup>3</sup>	10 0.5 $V_{SS} + 2 / V_{DD} - 2$ 5 500 7 –70 –70 250	ppm/ $^{\circ}\text{C}$ typ $\Omega$ typ V min/max k $\Omega$ min pF max mA typ dB typ dB typ $\mu\text{V}$ max	
ANALOG OUTPUT (OFFS_OUT) Output Temperature Coefficient <sup>3, 4</sup> DC Output Impedance <sup>3</sup> Output Range Output Current Capacitive Load	10 1.3 50 to $REF\_IN - 12$ 10 100	ppm/ $^{\circ}\text{C}$ typ k $\Omega$ typ mV typ $\mu\text{A}$ max pF max	Source Current.
DIGITAL INPUTS <sup>3</sup> Input Current Input Low Voltage Input High Voltage Input Hysteresis (SCLK and $\overline{CS}$ Only) Input Capacitance	$\pm 10$ 0.8 0.4 2.4 2.0 200 10	$\mu\text{A}$ max V max V max V min V min mV typ pF max	5 $\mu\text{A}$ typ. $DV_{CC} = 5\text{ V} \pm 5\%$ . $DV_{CC} = 3\text{ V} \pm 10\%$ . $DV_{CC} = 5\text{ V} \pm 5\%$ . $DV_{CC} = 3\text{ V} \pm 10\%$ .
DIGITAL OUTPUTS ( $\overline{BUSY}$ , DOUT) <sup>3</sup> Output Low Voltage Output High Voltage Output Low Voltage Output High Voltage High Impedance Leakage Current High Impedance Output Capacitance	0.4 4.0 0.4 2.4 $\pm 1$ 15	V max V min V max V min $\mu\text{A}$ max pF typ	$DV_{CC} = 5\text{ V}$ . Sinking 200 $\mu\text{A}$ . $DV_{CC} = 5\text{ V}$ . Sourcing 200 $\mu\text{A}$ . $DV_{CC} = 3\text{ V}$ . Sinking 200 $\mu\text{A}$ . $DV_{CC} = 3\text{ V}$ . Sourcing 200 $\mu\text{A}$ . DOUT Only. DOUT Only.

Parameter <sup>1</sup>	A Version <sup>2</sup>	Unit	Conditions/Comments
<b>POWER REQUIREMENTS</b>			
Power Supply Voltages			
V <sub>DD</sub>	8/16.5	V min/max	
V <sub>SS</sub>	-4.75/-16.5	V min/max	
AV <sub>CC</sub>	4.75/5.25	V min/max	
DV <sub>CC</sub>	2.7/5.25	V min/max	
Power Supply Currents <sup>6</sup>			
I <sub>DD</sub>	15	mA max	10 mA typ. All Channels Full-Scale.
I <sub>SS</sub>	15	mA max	10 mA typ. All Channels Full-Scale.
AI <sub>CC</sub>	33	mA max	26 mA typ.
DI <sub>CC</sub>	1.5	mA max	1 mA typ.
Power Dissipation <sup>6</sup>	280	mW typ	V <sub>DD</sub> = +10 V, V <sub>SS</sub> = -5 V.

## NOTES

<sup>1</sup>See Terminology.<sup>2</sup>A Version: Industrial temperature range -40°C to +85°C; typical at +25°C.<sup>3</sup>Guaranteed by design and characterization, not production tested.<sup>4</sup>AD780 as reference for the AD5533.<sup>5</sup>Ensure that you do not exceed T<sub>J</sub> (max). See maximum ratings.<sup>6</sup>Outputs unloaded.

Specifications subject to change without notice.

## AC CHARACTERISTICS

(V<sub>DD</sub> = 8 V to 16.5 V, V<sub>SS</sub> = -4.75 V to -16.5 V; AV<sub>CC</sub> = 4.75 V to 5.25 V; DV<sub>CC</sub> = 2.7 V to 5.25 V; AGND = DGND = DAC\_GND = 0 V; REF\_IN = 3 V; Output Range from V<sub>SS</sub> + 2 V to V<sub>DD</sub> - 2 V. All outputs unloaded. All specifications T<sub>MIN</sub> to T<sub>MAX</sub>, unless otherwise noted.)

Parameter	A Version <sup>1</sup>	Unit	Conditions/Comments
Output Settling Time <sup>2</sup>	3	μs max	500 pF, 5 kΩ Load; 0 V-3 V Step
Acquisition Time	16	μs max	
OFFS_IN Settling Time <sup>2</sup>	10	μs max	
Digital Feedthrough <sup>2</sup>	0.2	nV-s typ	
Output Noise Spectral Density @ 1 kHz <sup>2</sup>	400	nV/(√Hz) typ	
AC Crosstalk <sup>2</sup>	5	nV-s typ	

## NOTES

<sup>1</sup>A Version: Industrial temperature range -40°C to +85°C; typical at 25°C.<sup>2</sup>Guaranteed by design and characterization, not production tested.

Specifications subject to change without notice.

# AD5533

## TIMING CHARACTERISTICS

### PARALLEL INTERFACE

Parameter <sup>1, 2</sup>	Limit at T <sub>MIN</sub> , T <sub>MAX</sub> (A Version)	Unit	Conditions/Comments
t <sub>1</sub>	0	ns min	$\overline{\text{CS}}$ to $\overline{\text{WR}}$ Setup Time
t <sub>2</sub>	0	ns min	$\overline{\text{CS}}$ to $\overline{\text{WR}}$ Hold Time
t <sub>3</sub>	50	ns min	$\overline{\text{CS}}$ Pulsewidth Low
t <sub>4</sub>	50	ns min	$\overline{\text{WR}}$ Pulsewidth Low
t <sub>5</sub>	20	ns min	A4–A0, CAL, OFFS_SEL to $\overline{\text{WR}}$ Setup Time
t <sub>6</sub>	7	ns min	A4–A0, CAL, OFFS_SEL to $\overline{\text{WR}}$ Hold Time

#### NOTES

<sup>1</sup>See Interface Timing Diagram.

<sup>2</sup>Guaranteed by design and characterization, not production tested.

Specifications subject to change without notice.

### SERIAL INTERFACE

Parameter <sup>1, 2</sup>	Limit at T <sub>MIN</sub> , T <sub>MAX</sub> (A Version)	Unit	Conditions/Comments
f <sub>CLKIN</sub>	20	MHz max	SCLK Frequency
t <sub>1</sub>	20	ns min	SCLK High Pulsewidth
t <sub>2</sub>	20	ns min	SCLK Low Pulsewidth
t <sub>3</sub>	15	ns min	$\overline{\text{SYNC}}$ Falling Edge to SCLK Falling Edge Setup Time
t <sub>4</sub>	50	ns min	$\overline{\text{SYNC}}$ Low Time
t <sub>5</sub>	10	ns min	D <sub>IN</sub> Setup Time
t <sub>6</sub>	5	ns min	D <sub>IN</sub> Hold Time
t <sub>7</sub>	5	ns min	$\overline{\text{SYNC}}$ Falling Edge to SCLK Rising Edge Setup Time for Read Back
t <sub>8</sub> <sup>3</sup>	20	ns max	SCLK Rising Edge to D <sub>OUT</sub> Valid
t <sub>9</sub> <sup>3</sup>	60	ns max	SCLK Falling Edge to D <sub>OUT</sub> High Impedance
t <sub>10</sub>	400	ns min	10th SCLK Falling Edge to $\overline{\text{SYNC}}$ Falling Edge for Read Back
t <sub>11</sub> <sup>4</sup>	7	ns min	SCLK Falling Edge to $\overline{\text{SYNC}}$ Falling Edge Setup Time for Read Back

#### NOTES

<sup>1</sup>See Serial Interface Timing Diagrams.

<sup>2</sup>Guaranteed by design and characterization, not production tested.

<sup>3</sup>These numbers are measured with the load circuit of Figure 2.

<sup>4</sup> $\overline{\text{SYNC}}$  should be taken low while SCLK is low for read back.

Specifications subject to change without notice.

### PARALLEL INTERFACE TIMING DIAGRAM

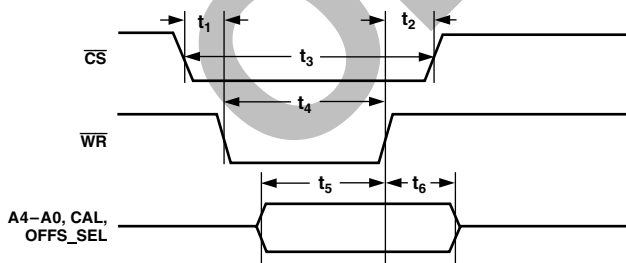

Figure 1. Parallel Write (ISHA Mode Only)

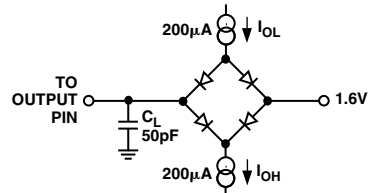

Figure 2. Load Circuit for D<sub>OUT</sub> Timing Specifications

SERIAL INTERFACE TIMING DIAGRAMS

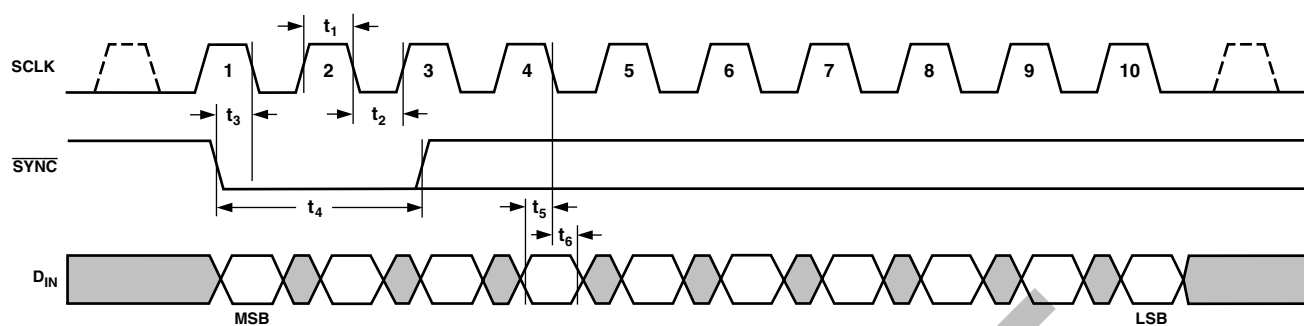

Figure 3. 10-Bit Write (ISHA Mode and Both Readback Modes)

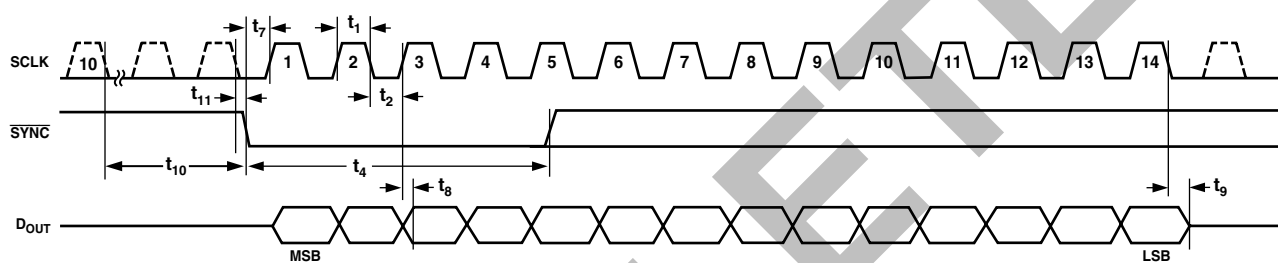

Figure 4. 14-Bit Read (Both Readback Modes)

OBSOLETE

# AD5533

## ABSOLUTE MAXIMUM RATINGS<sup>1, 2</sup>

(T<sub>A</sub> = 25°C, unless otherwise noted)

V <sub>DD</sub> to AGND	−0.3 V to +17 V
V <sub>SS</sub> to AGND	+0.3 V to −17 V
AV <sub>CC</sub> to AGND, DAC_GND	−0.3 V to +7 V
DV <sub>CC</sub> to DGND	−0.3 V to +7 V
Digital Inputs to DGND	−0.3 V to DV <sub>CC</sub> + 0.3 V
Digital Outputs to DGND	−0.3 V to DV <sub>CC</sub> + 0.3 V
REF_IN to AGND, DAC_GND	−0.3 V to AV <sub>CC</sub> + 0.3 V
V <sub>IN</sub> to AGND, DAC_GND	−0.3 V to AV <sub>CC</sub> + 0.3 V
V <sub>OUT</sub> 0–31 to AGND	V <sub>SS</sub> − 0.3 V to V <sub>DD</sub> + 0.3 V
OFFS_IN to AGND	V <sub>SS</sub> − 0.3 V to V <sub>DD</sub> + 0.3 V
OFFS_OUT to AGND	AGND − 0.3 V to AV <sub>CC</sub> + 0.3 V
AGND to DGND	−0.3 V to +0.3 V
<b>Operating Temperature Range</b>	
Industrial	−40°C to +85°C
<b>Storage Temperature Range</b>	
	−65°C to +150°C
<b>Junction Temperature (T<sub>J</sub> max)</b>	
	150°C
<b>74-Lead CSPBGA Package, θ<sub>JA</sub> Thermal Impedance</b>	
	41°C/W
<b>Reflow Soldering</b>	
Peak Temperature	220°C
Time at Peak Temperature	10 sec to 40 sec

Max Power Dissipation	(150°C − T <sub>A</sub> )/θ <sub>JA</sub> mW <sup>3</sup>
Max Continuous Load Current at T <sub>J</sub> = 70°C,	
per Channel Group	15.5 mA <sup>4</sup>

### NOTES

<sup>1</sup> Stresses above those listed under Absolute Maximum Ratings may cause permanent damage to the device. This is a stress rating only; functional operation of the device at these or any other conditions above those listed in the operational sections of this specification is not implied. Exposure to absolute maximum rating conditions for extended periods may affect device reliability.

<sup>2</sup> Transient currents of up to 100 mA will not cause SCR latch-up.

<sup>3</sup> This limit includes load power.

<sup>4</sup> This maximum allowed continuous load current is spread over eight channels and channels are grouped as follows:

Group 1: Channels 3, 4, 5, 6, 7, 8, 9, 10

Group 2: Channels 14, 16, 18, 20, 21, 24, 25, 26

Group 3: Channels 15, 17, 19, 22, 23, 27, 28, 29

Group 4: Channels 0, 1, 2, 11, 12, 13, 30, 31

For higher junction temperatures derate as follows:

T <sub>J</sub> (°C)	Max Continuous Load Current per Group (mA)
70	15.5
90	9.025
100	6.925
110	5.175
125	3.425
135	2.55
150	1.5

## ORDERING GUIDE

Model	Function	Output Impedance	Output Voltage Span	Package Description	Package Option
AD5533ABC-1	32-Channel ISHA Only	0.5 Ω typ	10 V	74-Lead CSPBGA	BC-74
AD5533ABC-1REEL	32-Channel ISHA Only	0.5 Ω typ	10 V	74-Lead CSPBGA	BC-74
AD5533BBC-1*	32-Channel Precision ISHA Only	0.5 Ω typ	10 V	74-Lead CSPBGA	BC-74
AD5532ABC-1*	32 DACs, 32-Channel ISHA	0.5 Ω typ	10 V	74-Lead CSPBGA	BC-74
AD5532ABC-2*	32 DACs, 32-Channel ISHA	0.5 Ω typ	20 V	74-Lead CSPBGA	BC-74
AD5532ABC-3*	32 DACs, 32-Channel ISHA	500 Ω typ	10 V	74-Lead CSPBGA	BC-74
AD5532ABC-5*	32 DACs, 32-Channel ISHA	1 kΩ typ	10 V	74-Lead CSPBGA	BC-74
AD5532BBC-1*	32 DACs, 32-Channel Precision ISHA	0.5 Ω typ	10 V	74-Lead CSPBGA	BC-74
AD5532HS*	32-Channel High-Speed DAC	0.5 kΩ typ	5 V	74-Lead CSPBGA	BC-74
EVAL-AD5532EB	AD5532/AD5533 Evaluation Board				

\*Separate Data Sheet.

## CAUTION

ESD (electrostatic discharge) sensitive device. Electrostatic charges as high as 4000 V readily accumulate on the human body and test equipment and can discharge without detection. Although the AD5533 features proprietary ESD protection circuitry, permanent damage may occur on devices subjected to high energy electrostatic discharges. Therefore, proper ESD precautions are recommended to avoid performance degradation or loss of functionality.



PIN CONFIGURATION

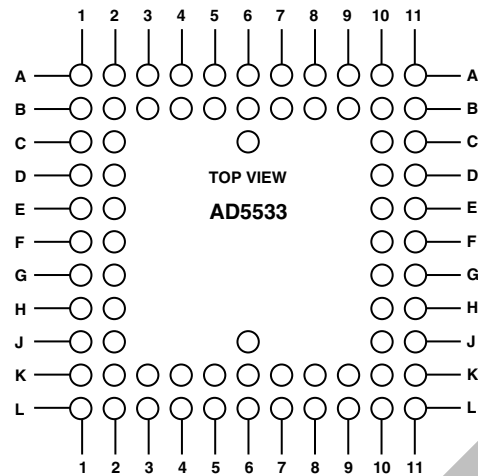

74-Lead CSPBGA Ball Configuration

CSPBGA Number	Ball Name	CSPBGA Number	Ball Name	CSPBGA Number	Ball Name
A1	N/C*	C10	AV <sub>CC1</sub>	J10	VO9
A2	A4	C11	REF_OUT	J11	VO11
A3	A2	D1	VO20	K1	VO17
A4	A0	D2	DAC_GND2	K2	VO15
A5	CS/SYNC	D10	AV <sub>CC2</sub>	K3	VO27
A6	DV <sub>CC</sub>	D11	OFFS_OUT	K4	V <sub>SS3</sub>
A7	SCLK	E1	VO26	K5	V <sub>SS1</sub>
A8	OFFSET_SEL	E2	VO14	K6	V <sub>SS4</sub>
A9	BUSY	E10	AGND1	K7	V <sub>DD2</sub>
A10	TRACK/RESET	E11	OFFS_IN	K8	VO2
A11	N/C*	F1	VO25	K9	VO10
B1	VO16	F2	VO21	K10	VO13
B2	N/C*	F10	AGND2	K11	VO12
B3	A3	F11	VO6	L1	N/C*
B4	A1	G1	VO24	L2	VO28
B5	WR	G2	VO8	L3	VO29
B6	DGND	G10	VO5	L4	VO30
B7	D <sub>IN</sub>	G11	VO3	L5	V <sub>DD3</sub>
B8	CAL	H1	VO23	L6	V <sub>DD1</sub>
B9	SER/PAR	H2	V <sub>IN</sub>	L7	V <sub>DD4</sub>
B10	D <sub>OUT</sub>	H10	VO4	L8	VO31
B11	REF_IN	H11	VO7	L9	VO0
C1	VO18	J1	VO22	L10	VO1
C2	DAC_GND1	J2	VO19	L11	N/C*
C6	N/C*	J6	V <sub>SS2</sub>		

\*N/C = unconnected

## PIN FUNCTION DESCRIPTIONS

Pin	Function
AGND(1–2)	Analog GND Pins
AV <sub>CC</sub> (1–2)	Analog Supply Pins. Voltage range from 4.75 V to 5.25 V.
V <sub>DD</sub> (1–4)	V <sub>DD</sub> Supply Pins. Voltage range from 8 V to 16.5 V.
V <sub>SS</sub> (1–4)	V <sub>SS</sub> Supply Pins. Voltage range from –4.75 V to –16.5 V.
DGND	Digital GND Pins
DV <sub>CC</sub>	Digital Supply Pins. Voltage range from 2.7 V to 5.25 V.
DAC_GND(1–2)	Reference GND Supply for All the DACs
REF_IN	Reference Voltage for Channels 0–31
REF_OUT	Reference Output Voltage
V <sub>OUT</sub> (0–31)	Analog Output Voltages from the 32 Channels
V <sub>IN</sub>	Analog Input Voltage
A4–A1 <sup>1</sup> , A0 <sup>2</sup>	Parallel Interface: 5-Address Pins for 32 Channels. A4 = MSB of Channel Address. A0 = LSB.
CAL <sup>1</sup>	Parallel Interface: Control input that allows all 32 channels to acquire V <sub>IN</sub> simultaneously.
$\overline{\text{CS/SYNC}}$	This pin is both the Active Low Chip Select Pin for the parallel interface and the Frame Synchronization Pin for the serial interface.
$\overline{\text{WR}}$ <sup>1</sup>	Parallel Interface: Write Pin. Active low. This is used in conjunction with the $\overline{\text{CS}}$ Pin to address the device using the parallel interface.
OFFSET_SEL <sup>1</sup>	Parallel Interface: Offset Select Pin. Active high. This is used to select the offset channel.
SCLK <sup>2</sup>	Serial Clock Input for Serial Interface. This operates at clock speeds up to 20 MHz.
D <sub>IN</sub> <sup>2</sup>	Data Input for Serial Interface. Data must be valid on the falling edge of SCLK.
D <sub>OUT</sub>	Output from the DAC Registers for read back. Data is clocked out on the rising edge of SCLK and is valid on the falling edge of SCLK.
SER/ $\overline{\text{PAR}}$ <sup>1</sup>	This pin allows the user to select whether the serial or parallel interface will be used. If the pin is tied low, the parallel interface will be used. If it is tied high, the serial interface will be used.
OFFS_IN	Offset Input. The user can supply a voltage here to offset the output span. OFFS_OUT can also be tied to this pin if the user wants to drive this pin with the offset channel.
OFFS_OUT	Offset Output. This is the acquired offset voltage that can be tied to the OFFS_IN Pin to offset the span.
$\overline{\text{BUSY}}$	This output tells the user when the input voltage is being acquired. It goes low during acquisition and returns high when the acquisition operation is complete.
$\overline{\text{TRACK/RESET}}$ <sup>2</sup>	If this input is held high, V <sub>IN</sub> is acquired once the channel is addressed. While it is held low, the input to the gain/offset stage is switched directly to V <sub>IN</sub> . The addressed channel begins to acquire V <sub>IN</sub> on the rising edge of $\overline{\text{TRACK}}$ . See $\overline{\text{TRACK}}$ Function section for further information. This input can also be used as a means of resetting the complete device to its power-on-reset conditions. This is achieved by applying a low-going pulse of between 90 ns and 200 ns to this pin. See section on $\overline{\text{RESET}}$ Function for further details.

## NOTES

<sup>1</sup>Internal pull-down devices on these logic inputs. Therefore, they can be left floating and will default to a logic low condition.

<sup>2</sup>Internal pull-up devices on these logic inputs. Therefore, they can be left floating and will default to a logic high condition.



## TERMINOLOGY

### $V_{IN}$ to $V_{OUT}$ Nonlinearity

This is a measure of the maximum deviation from a straight line passing through the endpoints of the  $V_{IN}$  versus  $V_{OUT}$  transfer function. It is expressed as a percentage of the full-scale span.

### Offset Error

This is a measure of the output error when  $V_{IN} = 70$  mV. Ideally, with  $V_{IN} = 70$  mV:

$$V_{OUT} = (Gain \times 70) - ((Gain - 1) \times V_{OFFS\_IN}) \text{ mV}$$

Offset error is a measure of the difference between  $V_{OUT}$  (actual) and  $V_{OUT}$  (ideal). It is expressed in mV and can be positive or negative. See Figure 5.

### Gain Error

This is a measure of the span error of the analog channel. It is the deviation in slope of the transfer function. See Figure 5. It is calculated as:

$$\text{Gain Error} = \text{Actual Full-Scale Output} - \text{Ideal Full-Scale Output} - \text{Offset Error}$$

where:

$$\text{Ideal Full-Scale Output} =$$

$$\text{Ideal Gain} \times 2.96 - ((\text{Ideal Gain} - 1) \times V_{OFFS\_IN})$$

$$\text{Ideal Gain} = 3.52$$

### Output Temperature Coefficient

This is a measure of the change in analog output with changes in temperature. It is expressed in ppm/ $^{\circ}$ C.

### DC Power Supply Rejection Ratio

DC power supply rejection ratio (PSRR) is a measure of the change in the analog output for a change in the supply voltage ( $V_{DD}$  and  $V_{SS}$ ). It is expressed in dBs.  $V_{DD}$  and  $V_{SS}$  are varied  $\pm 5\%$ .

### DC Crosstalk

This is the dc change in the output level of one channel in response to a full-scale change in the output of all other channels. It is expressed in  $\mu$ V.

### Output Settling Time

This is the time taken from when  $\overline{\text{BUSY}}$  goes high to when the output has settled to  $\pm 0.018\%$ .

### Acquisition Time

This is the time taken for the  $V_{IN}$  input to be acquired. It is the length of time that  $\overline{\text{BUSY}}$  stays low.

### OFFS\_IN Settling Time

This is the time taken from a 0 V–3 V step change in input voltage on OFFS\_IN until the output has settled to within  $\pm 0.39\%$ .

### Digital Feedthrough

This is a measure of the impulse injected into the analog outputs from the digital control inputs when the part is not being written to, i.e.,  $\overline{\text{CS/SYNC}}$  is high. It is specified in nV-s and is measured with a worst-case change on the Digital Input Pins, e.g., from all 0s to all 1s and vice versa.

### Output Noise Spectral Density

This is a measure of internally generated random noise. Random noise is characterized as a spectral density (voltage per root Hertz). It is measured by loading all DACs to midscale and measuring noise at the output. It is measured in  $\text{nV}/(\sqrt{\text{Hz}})$ .

### AC Crosstalk

This is the area of the glitch that occurs on the output of one channel while another channel is acquiring. It is expressed in nV-s.

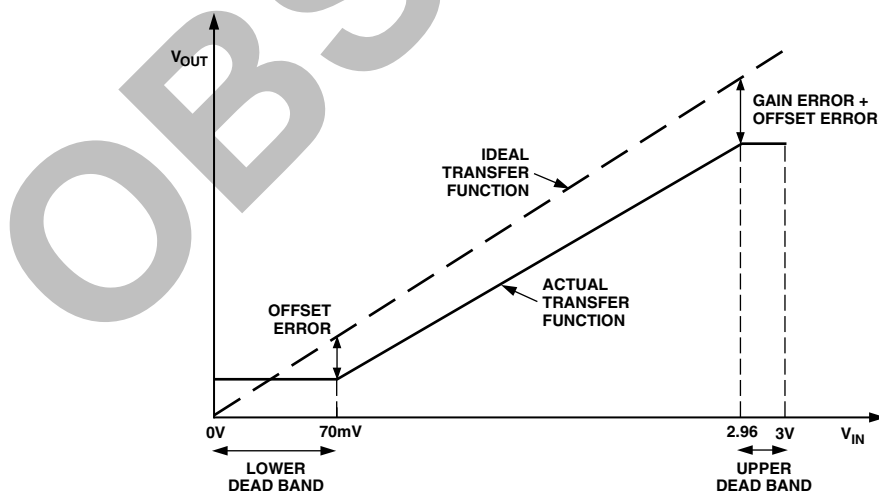
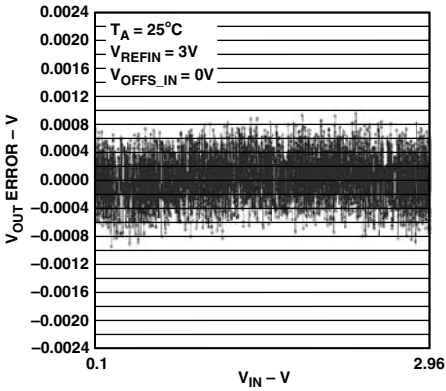
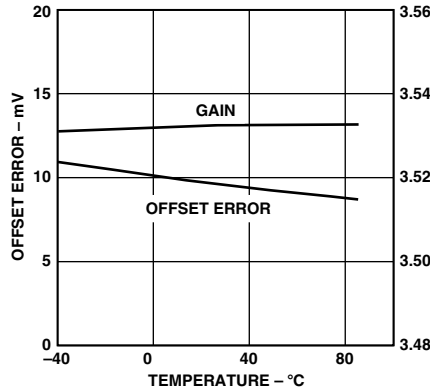

Figure 5. ISHA Transfer Function

# AD5533—Typical Performance Characteristics



TPC 1.  $V_{IN}$  to  $V_{OUT}$  Accuracy after Offset and Gain Adjustment



TPC 2. Offset Error and Gain vs. Temperature

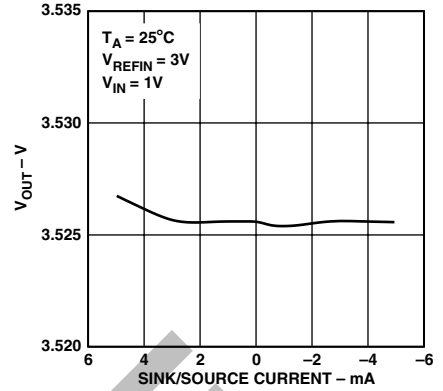

TPC 3.  $V_{OUT}$  Source and Sink Capability

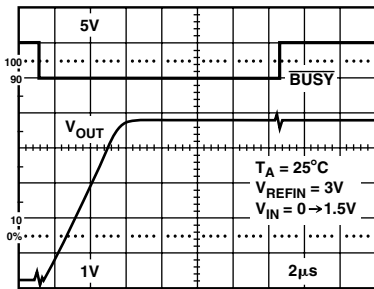

TPC 4. Acquisition Time and Output Settling Time

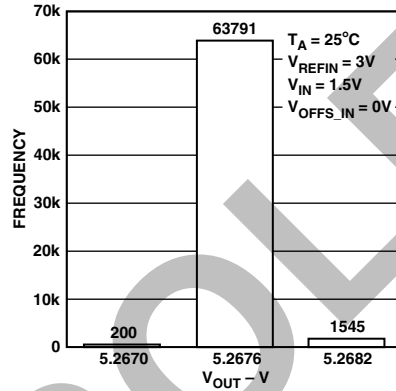

TPC 5. ISHA Mode Repeatability (64 K Acquisitions)

## FUNCTIONAL DESCRIPTION

The AD5533 can be thought of as consisting of an ADC and 32 DACs in a single package. The input voltage  $V_{IN}$  is sampled and converted into a digital word. The digital result is loaded into one of the DAC Registers and is converted (with gain and offset) into an analog output voltage ( $V_{OUT0}$ – $V_{OUT31}$ ). Since the channel output voltage is effectively the output of a DAC, there is no droop associated with it. As long as power to the device is maintained, the output voltage will remain constant until this channel is addressed again.

To update a single channel's output voltage, the required new voltage level is set up on the Common Input Pin,  $V_{IN}$ . The desired channel is then addressed via the Parallel Port or the Serial Port. When the channel address has been loaded, provided  $\overline{TRACK}$  is high, the circuit begins to acquire the correct code to load to the DAC in order that the DAC output matches the voltage on  $V_{IN}$ . The  $BUSY$  Pin goes low and remains so until the acquisition is complete. The noninverting input to the output buffer is tied to  $V_{IN}$  during the acquisition period to avoid spurious outputs, while the DAC acquires the correct code. The acquisition is completed in 16  $\mu$ s max. The  $BUSY$  Pin goes high and the updated DAC output assumes control of the output voltage. The output voltage of the DAC is connected to the noninverting input of the output buffer. Since the internal DACs are offset by 70 mV (max) from GND, the minimum  $V_{IN}$  in ISHA Mode is 70 mV. The maximum  $V_{IN}$  is 2.96 V due to the upper dead band of 40 mV (max).

On power-on, all the DACs, including the offset channel, are loaded with zeros. Each of the 33 DACs is offset internally by 50 mV (typ) from GND so the outputs  $V_{OUT0}$  to  $V_{OUT31}$  are 50 mV (typ) on power-on if the  $OFFS\_IN$  Pin is driven directly by the on-board offset channel ( $OFFS\_OUT$ ), i.e.: If  $OFFS\_IN = OFFS\_OUT = 50$  mV  $\Rightarrow V_{OUT} = (\text{Gain} \times V_{DAC}) - (\text{Gain} - 1) \times V_{OFFS\_IN} = 50$  mV.

### Analog Input

The equivalent analog input circuit is shown in Figure 6. The Capacitor C1 is typically 20 pF and can be attributed to the pin capacitance and 32 off-channels. When a channel is selected, an extra 7.5 pF (typ) is switched in. This Capacitor C2 is charged to the previously acquired voltage on that particular channel so it must charge/discharge to the new level. It is essential that the external source can charge/discharge this additional capacitance within 1  $\mu$ s–2  $\mu$ s of channel selection so that  $V_{IN}$  can be acquired accurately. For this reason a low impedance source is recommended.

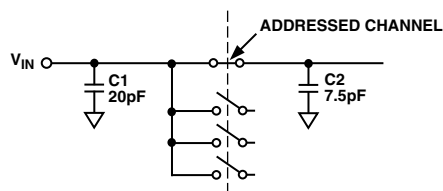

Figure 6. Analog Input Circuit

Large source impedances will significantly affect the performance of the ADC. This may necessitate the use of an input buffer amplifier.

### Output Buffer Stage—Gain and Offset

The function of the output buffer stage is to translate the 50 mV–3 V output of the DAC to a wider range. This is done by gaining up the DAC output by 3.52 and offsetting the voltage by the voltage on the  $OFFS\_IN$  Pin.

$$V_{OUT} = 3.52 \times V_{DAC} - 2.52 \times V_{OFFS\_IN}$$

$V_{DAC}$  is the output of the DAC.

$V_{OFFS\_IN}$  is the voltage at the  $OFFS\_IN$  Pin.

Table I shows how the output range on  $V_{OUT}$  relates to the offset voltage supplied by the user.

Table I. Sample Output Voltage Ranges

$V_{OFFS\_IN}$ (V)	$V_{DAC}$ (V)	$V_{OUT}$ (V)
0	0.05 to 3	0.176 to 10.56
1	0.05 to 3	–2.34 to +8.06
2,130	0.05 to 3	–5.192 to +5.192

$V_{OUT}$  is limited only by the headroom of the output amplifiers,  $V_{OUT}$  must be within the maximum ratings.

### Offset Voltage Channel

The offset voltage can be externally supplied by the user at  $OFFS\_IN$  or it can be supplied by an additional offset voltage channel on the device itself. The required offset voltage is set up on  $V_{IN}$  and acquired by the offset DAC. This offset channel's DAC output is directly connected to  $OFFS\_OUT$ . By connecting  $OFFS\_OUT$  to  $OFFS\_IN$  this offset voltage can be used as the offset voltage for the 32-output amplifiers. It is important to choose the offset so that  $V_{OUT}$  is within maximum ratings.

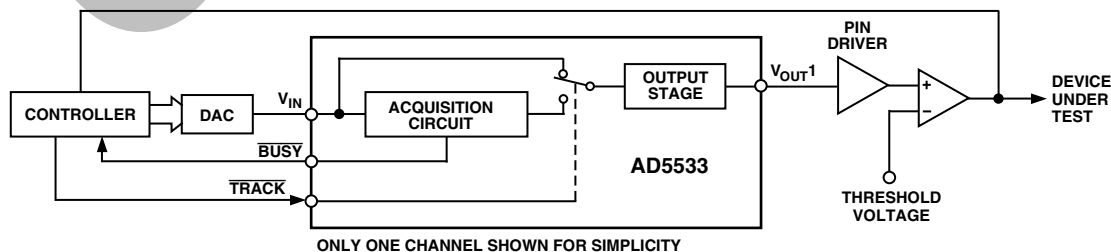

Figure 7. Typical ATE Circuit Using  $\overline{TRACK}$  Input

# AD5533

## Reset Function

The reset function on the AD5533 can be used to reset all nodes on this device to their power-on-reset condition. This is implemented by applying a low-going pulse of between 90 ns and 200 ns to the  $\overline{\text{TRACK/RESET}}$  Pin on the device. If the applied pulse is less than 90 ns, it is assumed to be a glitch and no operation takes place. If the applied pulse is wider than 200 ns, this pin adopts its  $\overline{\text{TRACK}}$  function on the selected channel,  $V_{\text{IN}}$  is switched to the output buffer, and an acquisition on the channel will not occur until a rising edge of  $\overline{\text{TRACK}}$ .

## $\overline{\text{TRACK}}$ Function

Normally in the ISHA Mode of operation,  $\overline{\text{TRACK}}$  is held high and the channel begins to acquire when it is addressed. However, if  $\overline{\text{TRACK}}$  is low when the channel is addressed,  $V_{\text{IN}}$  is switched to the output buffer and an acquisition on the channel will not occur until a rising edge of  $\overline{\text{TRACK}}$ . At this stage, the  $\overline{\text{BUSY}}$  Pin will go low until the acquisition is complete, at which point the DAC assumes control of the voltage to the output buffer and  $V_{\text{IN}}$  is free to change again without affecting this output value.

This is useful in an application where the user wants to ramp up  $V_{\text{IN}}$  until  $V_{\text{OUT}}$  reaches a particular level (Figure 7).  $V_{\text{IN}}$  does not need to be acquired continuously while it is ramping up.  $\overline{\text{TRACK}}$  can be kept low and only when  $V_{\text{OUT}}$  has reached its desired voltage is  $\overline{\text{TRACK}}$  brought high. At this stage, the acquisition of  $V_{\text{IN}}$  begins.

In the example shown, a desired voltage is required on the output of the pin driver. This voltage is represented by one input to a comparator. The  $\mu\text{C}/\mu\text{P}$  ramps up the input voltage on  $V_{\text{IN}}$  through a DAC.  $\overline{\text{TRACK}}$  is kept low while the voltage on  $V_{\text{IN}}$  ramps up so that  $V_{\text{IN}}$  is not continually acquired. When the desired voltage is reached on the output of the pin driver, the comparator output switches. The  $\mu\text{C}/\mu\text{P}$  then knows what code is required to be input in order to obtain the desired voltage at the DUT. The  $\overline{\text{TRACK}}$  input is now brought high and the part begins to acquire  $V_{\text{IN}}$ .  $\overline{\text{BUSY}}$  goes low until  $V_{\text{IN}}$  has been acquired. When  $\overline{\text{BUSY}}$  goes high, the output buffer is switched from  $V_{\text{IN}}$  to the output of the DAC.

## MODES OF OPERATION

The AD5533 can be used in three different modes. These modes are set by two mode bits, the first two bits in the serial word. The 01 option (DAC Mode) is not available for the AD5533. To avail of this mode, refer to the AD5532 data sheet. If you attempt to set up DAC Mode, the AD5533 will enter a Test Mode and a 24-clock write will be necessary to clear this.

Table II. Modes of Operation

Mode Bit 1	Mode Bit 2	Operating Mode
0	0	ISHA Mode
0	1	DAC Mode (Not Available)
1	0	Acquire and Read Back
1	1	Read Back

## 1. ISHA Mode

In this standard mode, a channel is addressed and that channel acquires the voltage on  $V_{\text{IN}}$ . This mode requires a 10-bit write to address the relevant channel ( $V_{\text{OUT}0}$ – $V_{\text{OUT}31}$ , offset channel or all channels). MSB is written first.

## 2. Acquire and Readback Mode

This mode allows the user to acquire  $V_{\text{IN}}$  and read back the data in a particular DAC Register. The relevant channel is addressed (10-bit write, MSB first) and  $V_{\text{IN}}$  is acquired in 16  $\mu\text{s}$  (max). Following the acquisition, after the next falling edge of  $\overline{\text{SYNC}}$  the data in the relevant DAC Register is clocked out onto the  $D_{\text{OUT}}$  line in a 14-bit serial format. During read back  $D_{\text{IN}}$  is ignored. The full acquisition time must elapse before the DAC register data can be clocked out.

## 3. Readback Mode

Again, this is a Readback Mode but no acquisition is performed. The relevant channel is addressed (10-bit write, MSB first) and on the next falling edge of  $\overline{\text{SYNC}}$ , the data in the relevant DAC Register is clocked out onto the  $D_{\text{OUT}}$  line in a 14-bit serial format. The user must allow 400 ns (min) between the last SCLK falling edge in the 10-bit write and the falling edge of  $\overline{\text{SYNC}}$  in the 14-bit read back. The serial write and read words can be seen in Figure 8.

This feature allows the user to read back the DAC Register code of any of the channels. Read back is useful if the system has been calibrated and the user wants to know what code in the DAC corresponds to a desired voltage on  $V_{\text{OUT}}$ .

## INTERFACES

### Serial Interface

The  $\overline{\text{SER/PAR}}$  Pin is tied high to enable the serial interface and to disable the parallel interface. The serial interface is controlled by the four pins that follow.

### $\overline{\text{SYNC}}$ , $D_{\text{IN}}$ , SCLK

Standard 3-wire Interface Pins. The  $\overline{\text{SYNC}}$  Pin is shared with the CS function of the parallel interface.

### $D_{\text{OUT}}$

Data Out Pin for reading back the contents of the DAC Registers. The data is clocked out on the rising edge of SCLK and is valid on the falling edge of SCLK.

### CAL Bit

When this is high, all 32 channels acquire  $V_{\text{IN}}$  simultaneously. The acquisition time is then 45  $\mu\text{s}$  (typ) and accuracy may be reduced.

### OFFSET\_SEL Bit

If this bit is set high, the offset channel is selected and Bits A4–A0 are ignored.

### Test Bit

This must be set low for correct operation of the part.

### A4–A0

Used to address any one of the 32 channels (A4 = MSB of address, A0 = LSB).

### DB13–DB0

These are used in both Readback Modes to read a 14-bit word from the addressed DAC Register.

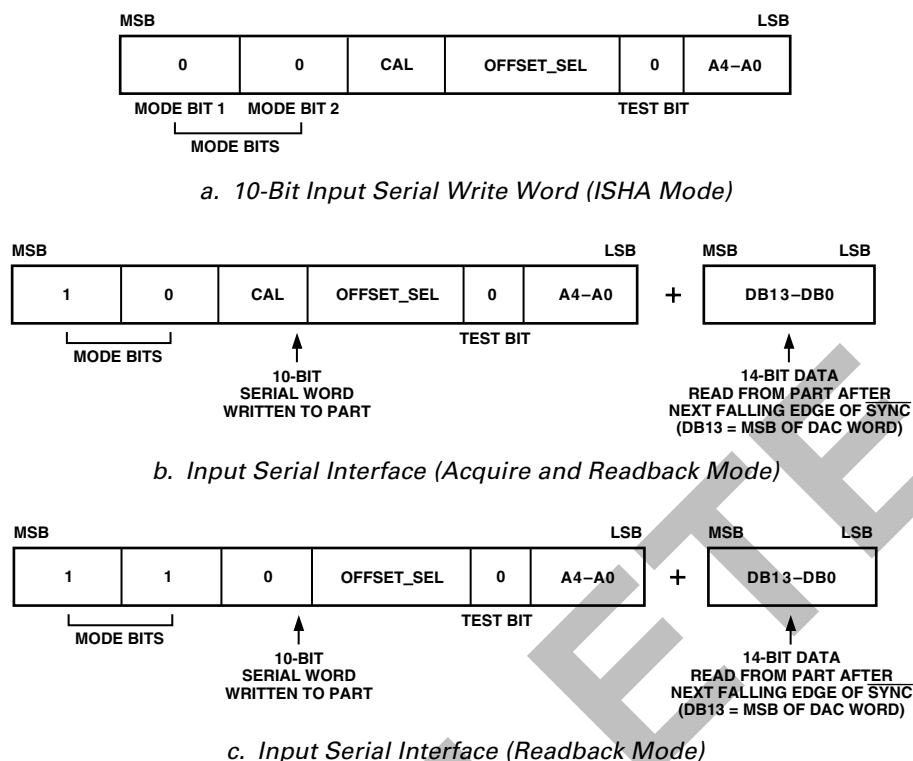

Figure 8. Serial Interface Formats

The serial interface is designed to allow easy interfacing to most microcontrollers and DSPs, e.g., PIC16C, PIC17C, QSPI™, SPI®, DSP56000, TMS320, and ADSP-21xx, without the need for any glue logic. When interfacing to the 8051, the SCLK must be inverted. The Microprocessor Interfacing section explains how to interface to some popular DSPs and microcontrollers.

Figures 3 and 4 show the timing diagram for a serial read and write to the AD5533. The serial interface works with both a continuous and a noncontinuous serial clock. The first falling edge of  $\overline{\text{SYNC}}$  resets a counter that counts the number of serial clocks to ensure the correct number of bits are shifted in and out of the Serial Shift Registers. Any further edges on  $\overline{\text{SYNC}}$  are ignored until the correct number of bits are shifted in or out. Once the correct number of bits have been shifted in or out, the SCLK is ignored. In order for another serial transfer to take place, the counter must be reset by the falling edge of  $\overline{\text{SYNC}}$ . In read back, the first rising SCLK edge after the falling edge of  $\overline{\text{SYNC}}$  causes  $D_{\text{OUT}}$  to leave its high impedance state and data is clocked out onto the  $D_{\text{OUT}}$  line and also on subsequent SCLK rising edges. The  $D_{\text{OUT}}$  Pin goes back into a high impedance state on the falling edge of the 14th SCLK. Data on the  $D_{\text{IN}}$  line is latched in on the first SCLK falling edge after the falling edge of the  $\overline{\text{SYNC}}$  signal and on subsequent SCLK falling edges. The serial interface will not shift data in or out until it receives the falling edge of the  $\overline{\text{SYNC}}$  signal.

#### Parallel Interface

The  $\overline{\text{SER/PAR}}$  Bit must be tied low to enable the parallel interface and disable the serial interface. The parallel interface is controlled by nine pins.

#### $\overline{\text{CS}}$

Active Low Package Select Pin. This pin is shared with the  $\overline{\text{SYNC}}$  function for the serial interface.

#### $\overline{\text{WR}}$

Active Low Write Pin. The values on the Address Pins are latched on a rising edge of  $\overline{\text{WR}}$ .

#### A4-A0

Five Address Pins (A4 = MSB of address, A0 = LSB). These are used to address the relevant channel (out of a possible 32).

#### OFFSET\_SEL

Offset Select Pin. This has the same function as the OFFSET\_SEL Bit in the serial interface. When it is high, the offset channel is addressed and the address on A4-A0 is ignored.

#### CAL

Same functionality as the CAL Bit in the serial interface. When this pin is high, all 32 channels acquire  $V_{\text{IN}}$  simultaneously.

# AD5533

## MICROPROCESSOR INTERFACING

### AD5533 to ADSP-21xx Interface

The ADSP-21xx family of DSPs are easily interfaced to the AD5533 without the need for extra logic.

A data transfer is initiated by writing a word to the Tx Register after the SPORT has been enabled. In a write sequence, data is clocked out on each rising edge of the DSP's serial clock and clocked into the AD5533 on the falling edge of its SCLK. In read back, 16 bits of data are clocked out of the AD5533 on each rising edge of SCLK and clocked into the DSP on the rising edge of SCLK.  $D_{IN}$  is ignored. The valid 14 bits of data will be centered in the 16-bit Rx Register when using this configuration. The SPORT Control Register should be set up as follows:

TFSW = RFSW = 1, Alternate Framing  
 INVRFS = INVTFS = 1, Active Low Frame Signal  
 DTYPE = 00, Right Justify Data  
 ISCLK = 1, Internal Serial Clock  
 TFSR = RFSR = 1, Frame Every Word  
 IRFS = 0, External Framing Signal  
 ITFS = 1, Internal Framing Signal  
 SLEN = 1001, 10-Bit Data-Words (ISHA Mode Write)  
 SLEN = 1111, 16-Bit Data-Words (Readback Mode)

Figure 9 shows the connection diagram.

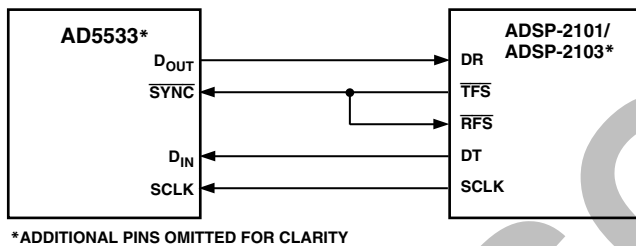

Figure 9. AD5533 to ADSP-2101/ADSP-2103 Interface

### AD5533 to MC68HC11

The Serial Peripheral Interface (SPI) on the MC68HC11 is configured for Master Mode (MSTR) = 1, Clock Polarity Bit (CPOL) = 0, and the Clock Phase Bit (CPHA) = 1. The SPI is configured by writing to the SPI Control Register (SPCR)—see *68HC11 User Manual*. SCK of the 68HC11 drives the SCLK of the AD5533, the MOSI output drives the serial data line ( $D_{IN}$ ) of the AD5533, and the MISO input is driven from  $D_{OUT}$ . The SYNC signal is derived from a port line (PC7). When data is being transmitted to the AD5533, the SYNC line is taken low (PC7). Data appearing on the MOSI output is valid on the falling edge of SCK. Serial data from the 68HC11 is transmitted in 8-bit bytes with only eight falling clock edges occurring in the transmit cycle. Data is transmitted MSB first. To transmit 10 data bits in ISHA Mode, it is important to left-justify the data in the

SPDR Register. PC7 must be pulled low to start a transfer. It is taken high and pulled low again before any further read/write cycles can take place. A connection diagram is shown in Figure 10.

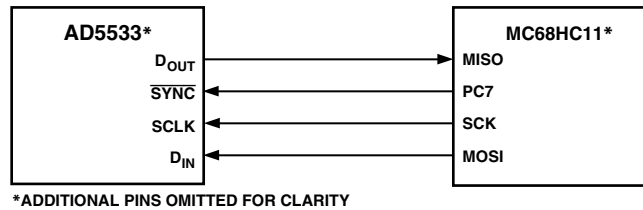

Figure 10. AD5533 to MC68HC11 Interface

### AD5533 to PIC16C6x/PIC16C7x

The PIC16C6x Synchronous Serial Port (SSP) is configured as an SPI Master with the Clock Polarity Bit = 0. This is done by writing to the Synchronous Serial Port Control Register (SSPCON). See *PIC16/PIC17 Microcontroller User Manual*. In this example, I/O port RA1 is being used to pulse SYNC and enable the serial port of the AD5533. This microcontroller transfers only eight bits of data during each serial transfer operation; therefore, two consecutive read/write operations are needed for a 10-bit write and a 14-bit read back. Figure 11 shows the connection diagram.

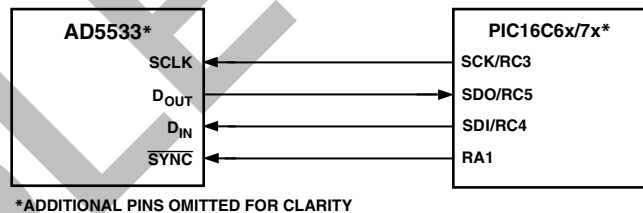

Figure 11. AD5533 to PIC16C6x/7x Interface

### AD5533 to 8051

The AD5533 requires a clock synchronized to the serial data. The 8051 serial interface must therefore be operated in Mode 0. In this mode, serial data enters and exits through RxD and a shift clock is output on TxD. Figure 12 shows how the 8051 is connected to the AD5533. Because the AD5533 shifts data out on the rising edge of the shift clock and latches data in on the falling edge, the shift clock must be inverted. The AD5533 requires its data with the MSB first. Since the 8051 outputs the LSB first, the transmit routine must take this into account.

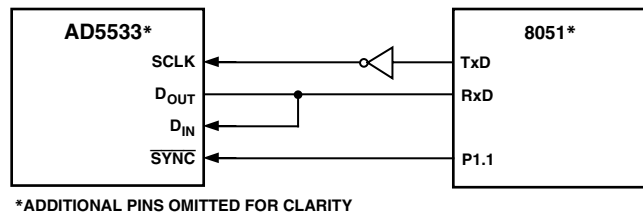

Figure 12. AD5533 to 8051 Interface

## APPLICATION CIRCUITS

### AD5533 in a Typical ATE System

The AD5533 infinite sample-and-hold is ideally suited for use in automatic test equipment. Several ISHAs are required to control pin drivers, comparators, active loads, and signal timing. Traditionally, sample-and-hold devices with droop were used in this application. These required refreshing to prevent the voltage from drifting.

The AD5533 has several advantages: no refreshing is required, there is no droop, pedestal error is eliminated, and there is no need for extra filtering to remove glitches. Overall, a higher level of integration is achieved in a smaller area, see Figure 13.

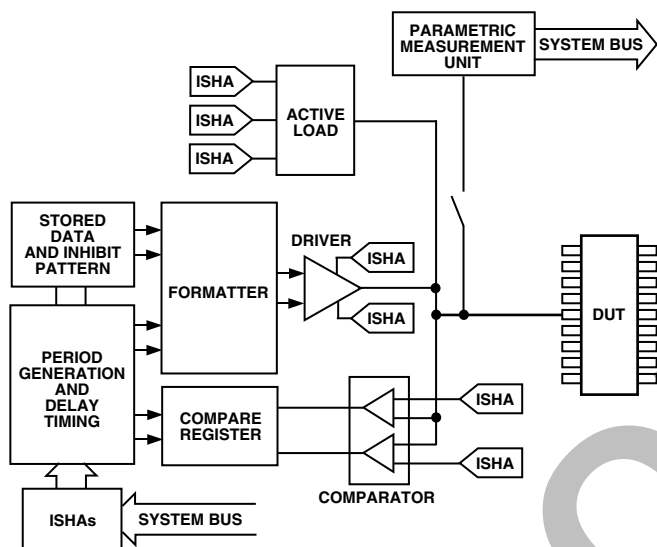

Figure 13. AD5533 in an ATE System

### Typical Application Circuit

The AD5533 can be used to set up voltage levels on 32 channels as shown in the circuit below. An AD780 provides the 3 V reference for the AD5533 and for the AD5541 16-bit DAC. A simple 3-wire interface is used to write to the AD5541. Because the AD5541 has an output resistance of 6.25 k $\Omega$  (typ), the time taken to charge/discharge the capacitance at the  $V_{IN}$  Pin is significant. Hence an AD820 is used to buffer the DAC output. Note that it is important to minimize noise on  $V_{IN}$  and  $REF_{IN}$  when laying out this circuit.

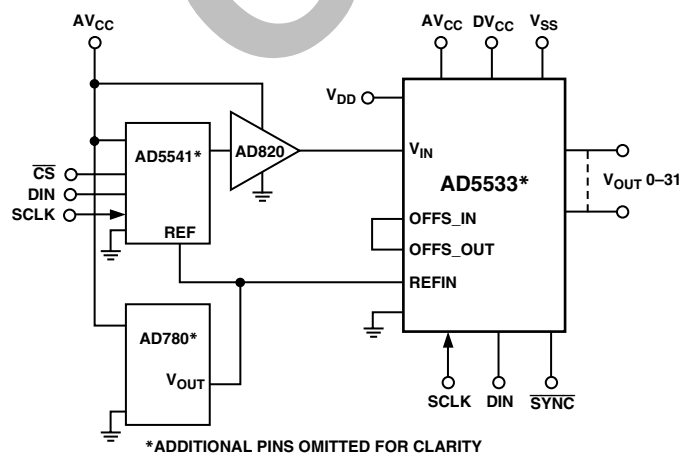

Figure 14. Typical Application Circuit

## POWER SUPPLY DECOUPLING

In any circuit where accuracy is important, careful consideration of the power supply and ground return layout helps to ensure the rated performance. The printed circuit board on which the AD5533 is mounted should be designed so that the analog and digital sections are separated and confined to certain areas of the board. If the AD5533 is in a system where multiple devices require an AGND-to-DGND connection, the connection should be made at one point only. The star ground point should be established as close as possible to the device. For supplies with multiple pins ( $V_{SS}$ ,  $V_{DD}$ , and  $AV_{CC}$ ), it is recommended to tie those pins together. The AD5533 should have ample supply bypassing of 10  $\mu\text{F}$  in parallel with 0.1  $\mu\text{F}$  on each supply located as close to the package as possible, ideally right up against the device. The 10  $\mu\text{F}$  capacitors are the tantalum bead type. The 0.1  $\mu\text{F}$  capacitor should have low effective series resistance (ESR) and effective series inductance (ESI), like the common ceramic types that provide a low impedance path to ground at high frequencies, to handle transient currents due to internal logic switching.

The power supply lines of the AD5533 should use as large a trace as possible to provide low impedance paths and reduce the effects of glitches on the power supply line. Fast switching signals, such as clocks, should be shielded with digital ground to avoid radiating noise to other parts of the board and should never be run near the reference inputs. A ground line routed between the  $D_{IN}$  and  $SCLK$  lines will help reduce crosstalk between them (not required on a multilayer board as there will be a separate ground plane but separating the lines will help).

Note it is essential to minimize noise on  $V_{IN}$  and  $REF_{IN}$  lines. Particularly for optimum ISHA performance, the  $V_{IN}$  line must be kept noise-free. Depending on the noise performance of the board, a noise filtering capacitor may be required on the  $V_{IN}$  line. If this capacitor is necessary, then for optimum throughput it may be necessary to buffer the source which is driving  $V_{IN}$ . Avoid crossover of digital and analog signals. Traces on opposite sides of the board should run at right angles to each other. This reduces the effects of feedthrough through the board. A microstrip technique is by far the best but not always possible with a double-sided board. In this technique, the component side of the board is dedicated to ground plane while signal traces are placed on the solder side.

As is the case for all thin packages, care must be taken to avoid flexing the package and to avoid a point load on the surface of the package during the assembly process.

OUTLINE DIMENSIONS

74-Lead Chip Scale Ball Grid Array [CSPBGA]  
(BC-74)

Dimensions shown in millimeters

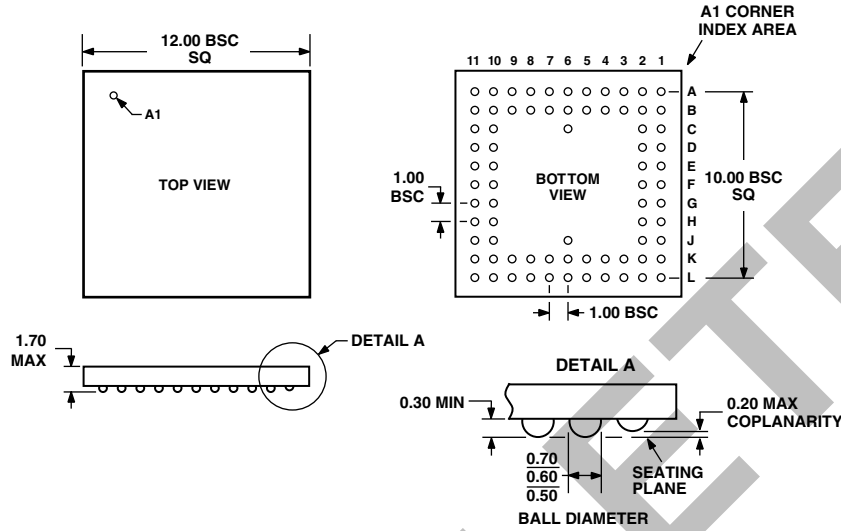

COMPLIANT TO JEDEC STANDARDS MO-192ABD-1

Revision History

Location	Page
7/03—Data Sheet changed from REV. 0 to REV. A.	
Term SHA changed to ISHA	Global
Term LFBGA updated to CSPBGA	Global
Changes to APPLICATIONS	1
Changes to SPECIFICATIONS	2
Changes to TIMING CHARACTERISTICS	4
Changes to ABSOLUTE MAXIMUM RATINGS	6
Changes to ORDERING GUIDE	6
Edits to PIN FUNCTION DESCRIPTION	8
Changes to TERMINOLOGY	9
Changes to FUNCTIONAL DESCRIPTION	11
Changes to Table I	11
Changes to APPLICATION CIRCUITS	15
Updated OUTLINE DIMENSIONS	16