

CMOS Micropower Over/Under Voltage Detector

The ICL7665S super CMOS micropower Over/Under voltage detector contains two low power, individually programmable voltage detectors on a single CMOS chip. Requiring typically 3µA for operation, the device is intended for battery-operated systems and instruments which require high or low voltage warnings, settable trip points, or fault monitoring and correction. The trip points and hysteresis of the two voltage detectors are individually programmed via external resistors. An internal bandgap type reference provides an accurate threshold voltage while operating from any supply in the 1.6V to 16V range.

The ICL7665S, super programmable Over/Under voltage detector is a direct replacement for the industry standard. The ICL7665B offering **wider** operating voltage and temperature ranges, **improved** threshold accuracy (ICL7665SA), and temperature coefficient, and **guaranteed** maximum supply current. All improvements are highlighted in the electrical characteristics section. **All critical parameters are guaranteed over the entire commercial and industrial temperature ranges.**

Pinout

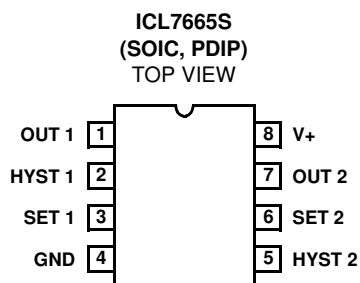

Features

- Guaranteed 10µA maximum quiescent current over-temperature
- Guaranteed wider operating voltage range over entire operating temperature range
- 2% threshold accuracy (ICL7665SA)
- Dual comparator with precision internal reference
- 100ppm/°C temperature coefficient of threshold voltage
- 100% tested at 2V
- Output current sinking ability Up to 20mA
- Individually programmable upper and lower trip voltages and hysteresis levels
- Pb-Free available (RoHS Compliant)

Applications

- Pocket pagers
- Portable instrumentation
- Charging systems
- Memory power back-up
- Battery operated systems
- Portable computers
- Level detectors

Ordering Information

PART NUMBER	PART MARKING	TEMP. RANGE (°C)	PACKAGE	PKG. DWG. #
ICL7665SACBA (Note 1)	7665S ACBA	0 to +70	8 Ld SOIC	M8.15
ICL7665SACBAZ (Notes 1, 3)	7665S ACBAZ	0 to +70	8 Ld SOIC (Pb-free)	M8.15
ICL7665SACBAZA (Notes 1, 3)	7665S ACBAZ	0 to +70	8 Ld SOIC (Pb-free)	M8.15
ICL7665SACPA	7665S ACPA	0 to +70	8 Ld PDIP	E8.3
ICL7665SACPAZ (Note 2)	7665S ACPAZ	0 to +70	8 Ld PDIP (Pb-free)	E8.3
ICL7665SAIBA (Note 1)	7665 SAIBA	-40 to +85	8 Ld SOIC	M8.15
ICL7665SAIBAZ (Notes 1, 3)	7665 SAIBAZ	-40 to +85	8 Ld SOIC (Pb-free)	M8.15
ICL7665SAIPA	7665S AIPA	-40 to +85	8 Ld PDIP	E8.3
ICL7665SAIPAZ (Note 2)	7665S AIPAZ	-40 to +85	8 Ld PDIP (Pb-free)	E8.3
ICL7665SCBA (Note 1)	7665 SCBA	0 to +70	8 Ld SOIC	M8.15
ICL7665SCBAZ (Notes 1, 3)	7665 SCBAZ	0 to +70	8 Ld SOIC (Pb-free)	M8.15
ICL7665SCBAZA (Notes 1, 3)	7665 SCBAZ	0 to +70	8 Ld SOIC (Pb-free)	M8.15
ICL7665SCPA	7665S CPA	0 to +70	8 Ld PDIP	E8.3
ICL7665SCPAZ (Note 2)	7665S CPAZ	0 to +70	8 Ld PDIP (Pb-free)	E8.3
ICL7665SIBAZ (Notes 1, 3)	7665 SIBAZ	-40 to +85	8 Ld SOIC (Pb-free)	M8.15
ICL7665SIBAZA (Notes 1, 3)	7665 SIBAZ	-40 to +85	8 Ld SOIC(Pb-free)	M8.15

NOTES:

1. Add "-T*" suffix for tape and reel. Please refer to [TB347](#) for details on reel specifications.
2. Pb-free PDIPs can be used for through hole wave solder processing only. They are not intended for use in Reflow solder processing applications.
3. Intersil Pb-free plus anneal products employ special Pb-free material sets; molding compounds/die attach materials and 100% matte tin plate termination finish, which are RoHS compliant and compatible with both SnPb and Pb-free soldering operations. Intersil Pb-free products are MSL classified at Pb-free peak reflow temperatures that meet or exceed the Pb-free requirements of IPC/JEDEC J STD-020.

Absolute Maximum Ratings

Supply Voltage (Note 5)	-0.3 to +18V
Output Voltages OUT1 and OUT2 (with respect to GND) (Note 5)	-0.3V to +18V
Output Voltages HYST1 and HYST2 (with respect to V+) (Note 5)	-0.3V to +18V
Input Voltages SET1 and SET2 (Note 5)	(GND -0.3V) to (V+ V- +0.3V)
Maximum Sink Output OUT1 and OUT2	25mA
Maximum Source Output Current HYST1 and HYST2	-25mA

Operating Conditions

Temperature Range	
ICL7665SC	0°C to +70°C
ICL7665SI	-40°C to +85°C

Thermal Information

Thermal Resistance (Typical, Note 4)	θ_{JA} (°C/W)
PDIP Package*	115
SOIC Package	160
Maximum Junction Temperature (Plastic)	+150°C
Maximum Junction Temperature (CERDIP)	+175°C
Maximum Storage Temperature Range	-65°C to +150°C
Maximum Lead Temperature (Soldering 10s) (SOIC - Lead Tips Only)	+300°C
Pb-Free Reflow Profile	see link below http://www.intersil.com/pbfree/Pb-FreeReflow.asp

*Pb-free PDIPs can be used for through hole wave solder processing only. They are not intended for use in Reflow solder processing applications.

CAUTION: Do not operate at or near the maximum ratings listed for extended periods of time. Exposure to such conditions may adversely impact product reliability and result in failures not covered by warranty.

NOTES:

- θ_{JA} is measured with the component mounted on an evaluation PC board in free air.
- Due to the SCR structure inherent in the CMOS process used to fabricate these devices, connecting any terminal to voltages greater than (V+ +0.3V) or less than (GND - 0.3V) may cause destructive device latchup. For these reasons, it is recommended that no inputs from external sources not operating from the same power supply be applied to the device before its supply is established, and that in multiple supply systems, the supply to the ICL7665S be turned on first. If this is not possible, current into inputs and/or outputs must be limited to ± 0.5 mA and voltages must not exceed those defined above.

Electrical Specifications The specifications below are applicable to both the ICL7665S and ICL7665SA. V+ = 5V, T_A = +25°C, Test Circuit Figure 7. Unless Otherwise Specified

PARAMETER	SYMBOL	TEST CONDITIONS	MIN	TYP	MAX	UNITS	
Operating Supply Voltage	V+	ICL7665S	T _A = +25°C	1.6	-	16	V
			0°C ≤ T _A ≤ +70°C	1.8	-	16	V
			-25°C ≤ T _A ≤ +85°C	1.8	-	16	V
		ICL7665SA	0°C ≤ T _A ≤ +70°C	1.8	-	16	V
			-25°C ≤ T _A ≤ +85°C	1.8	-	16	V
Supply Current	I+	GND ≤ V _{SET1} , V _{SET2} ≤ V+, All Outputs Open Circuit					
		0°C ≤ T _A ≤ +70°C	V+ = 2V	-	2.5	10	μA
			V+ = 9V	-	2.6	10	μA
			V+ = 15V	-	2.9	10	μA
		-40°C ≤ T _A ≤ +85°C	V+ = 2V	-	2.5	10	μA
			V+ = 9V	-	2.6	10	μA
			V+ = 15V	-	2.9	10	μA
Input Trip Voltage	V _{SET1}	ICL7665S	1.20	1.30	1.40	V	
	V _{SET2}		1.20	1.30	1.40	V	
	V _{SET1}	ICL7665SA	1.275	1.30	1.325	V	
	V _{SET2}		1.275	1.30	1.325	V	
Temperature Coefficient of V _{SET}	$\frac{\Delta V_{SET}}{\Delta T}$	ICL7665S	-	200	-	ppm	
		ICL7665SA	-	100	-	ppm	
Supply Voltage Sensitivity of V _{SET1} , V _{SET2}	$\frac{\Delta V_{SET}}{\Delta V_S}$	R _{OUT1} , R _{OUT2} , R _{HYST1} , R _{HYST2} = 1MΩ, 2V ≤ V+ ≤ 10V	-	0.03	-	%/V	

ICL7665S

Electrical Specifications The specifications below are applicable to both the ICL7665S and ICL7665SA. $V_+ = 5V$, $T_A = +25^\circ C$, Test Circuit Figure 7. Unless Otherwise Specified **(Continued)**

PARAMETER	SYMBOL	TEST CONDITIONS		MIN	TYP	MAX	UNITS
Output Leakage Currents of OUT and HYST	I_{OLK}	$V_{SET} = 0V$ or $V_{SET} \geq 2V$		-	10	200	nA
	I_{HLK}			-	-10	-100	nA
	I_{OLK}	$V_+ = 15V$		-	-	2000	nA
	I_{HLK}			-	-	-500	nA
Output Saturation Voltages	V_{OUT1}	$V_{SET1} = 2V$, $I_{OUT1} = 2mA$	$V_+ = 2V$	-	0.2	0.5	V
			$V_+ = 5V$	-	0.1	0.3	V
			$V_+ = 15V$	-	0.06	0.2	V
Output Saturation Voltages	V_{HYST1}	$V_{SET1} = 2V$, $I_{HYST1} = -0.5mA$	$V_+ = 2V$	-	-0.15	-0.30	V
			$V_+ = 5V$	-	-0.05	-0.15	V
			$V_+ = 15V$	-	-0.02	-0.10	V
Output Saturation Voltages	V_{OUT2}	$V_{SET2} = 0V$, $I_{OUT2} = 2mA$	$V_+ = 2V$	-	0.2	0.5	V
			$V_+ = 5V$	-	0.15	0.3	V
			$V_+ = 15V$	-	0.11	0.25	V
Output Saturation Voltages	V_{HYST2}	$V_{SET2} = 2V$	$V_+ = 2V$, $I_{HYST2} = -0.2mA$	-	-0.25	-0.8	V
			$V_+ = 5V$, $I_{HYST2} = -0.5mA$	-	-0.43	-1.0	V
			$V_+ = 15V$, $I_{HYST2} = -0.5mA$	-	-0.35	-0.8	V
V_{SET} Input Leakage Current	I_{SET}	$GND \leq V_{SET} \leq V_+$		-	0.01	10	nA
Δ Input for Complete Output Change	ΔV_{SET}	$R_{OUT} = 4.7k\Omega$, $R_{HYST} = 20k\Omega$, $V_{OUTLO} = 1\% V_+$, $V_{OUTH} = 99\% V_+$	ICL7665S	-	1.0	-	mV
			ICL7665SA	-	0.1	-	mV
Difference in Trip Voltages	$V_{SET1} - V_{SET2}$	$R_{OUT}, R_{HYST} = 1mW$		-	± 5	± 50	mV
Output/Hysteresis Difference		$R_{OUT}, R_{HYST} = 1mW$	ICL7665S	-	± 1	-	mV
			ICL7665SA	-	± 0.1	-	mV

NOTES:

6. Derate above $+25^\circ C$ ambient temperature at $4mW/^\circ C$.
7. All significant improvements over the industry standard ICL7665 are highlighted.

AC Electrical Specifications

PARAMETER	SYMBOL	TEST CONDITIONS	MIN	TYP	MAX	UNITS
OUTPUT DELAY TIMES						
Input Going HI	t_{SO1D}	V_{SET} Switched between 1.0V to 1.6V $R_{OUT} = 4.7k\Omega, C_L = 12pF$ $R_{HYST} = 20k\Omega, C_L = 12pF$	-	85	-	μs
	t_{SH1D}		-	90	-	μs
	t_{SO2D}		-	55	-	μs
	t_{SH2D}		-	55	-	μs
Input Going LO	$t_{\bar{S}O1D}$	V_{SET} Switched between 1.6V to 1.0V $R_{OUT} = 4.7k\Omega, C_L = 12pF$ $R_{HYST} = 20k\Omega, C_L = 12pF$	-	75	-	μs
	$t_{\bar{S}H1D}$		-	80	-	μs
	$t_{\bar{S}O2D}$		-	60	-	μs
	$t_{\bar{S}H2D}$		-	60	-	μs
Output Rise Times	t_{O1R}	V_{SET} Switched between 1.0V to 1.6V $R_{OUT} = 4.7k\Omega, C_L = 12pF$ $R_{HYST} = 20k\Omega, C_L = 12pF$	-	0.6	-	μs
	t_{O2R}		-	0.8	-	μs
	t_{H1R}		-	7.5	-	μs
	t_{H2R}		-	0.7	-	μs
Output Fall Times	t_{O1F}	V_{SET} Switched between 1.0V to 1.6V $R_{OUT} = 4.7k\Omega, C_L = 12pF$ $R_{HYST} = 20k\Omega, C_L = 12pF$	-	0.6	-	μs
	t_{O2F}		-	0.7	-	μs
	t_{H1F}		-	4.0	-	μs
	t_{H2F}		-	1.8	-	μs

Functional Block Diagram

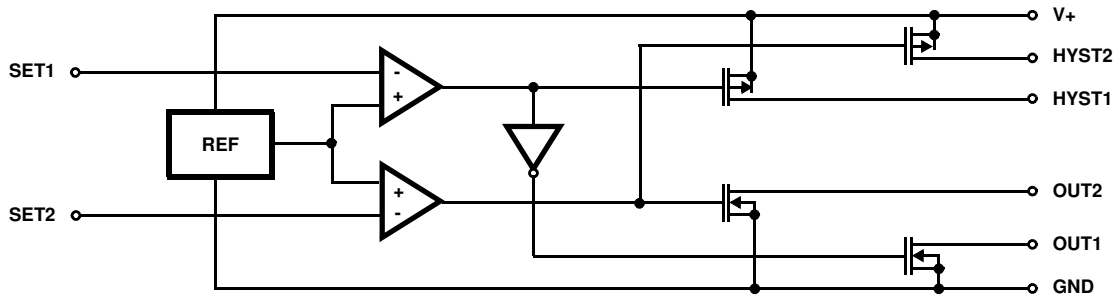

CONDITIONS (Note 5)

- $V_{SET1} > 1.3V$, OUT1 Switch ON, HYST1 Switch ON
- $V_{SET1} < 1.3V$, OUT1 Switch OFF, HYST1 Switch OFF
- $V_{SET2} > 1.3V$, OUT2 Switch OFF, HYST2 Switch ON
- $V_{SET2} < 1.3V$, OUT2 Switch ON, HYST2 Switch OFF

NOTE:

- 8. See Electrical Specifications for exact thresholds.

Typical Performance Curves

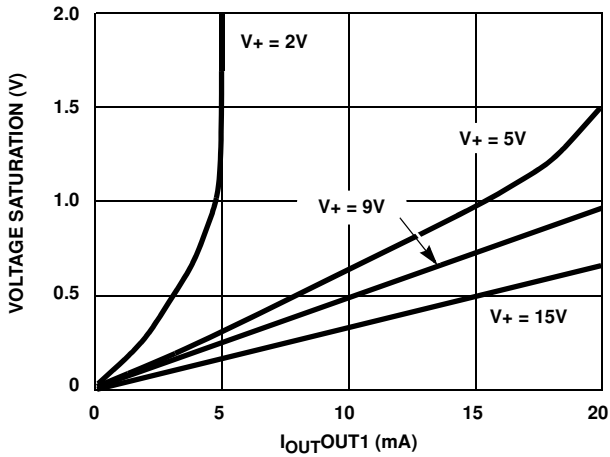

FIGURE 1. OUT1 SATURATION VOLTAGE AS A FUNCTION OF OUTPUT CURRENT

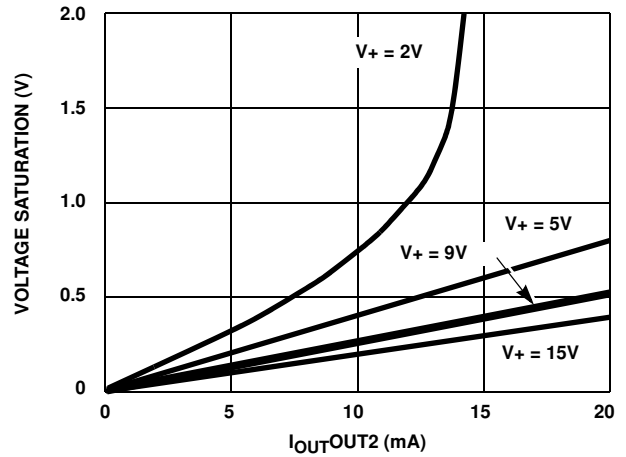

FIGURE 2. OUT2 SATURATION VOLTAGE AS A FUNCTION OF OUTPUT CURRENT

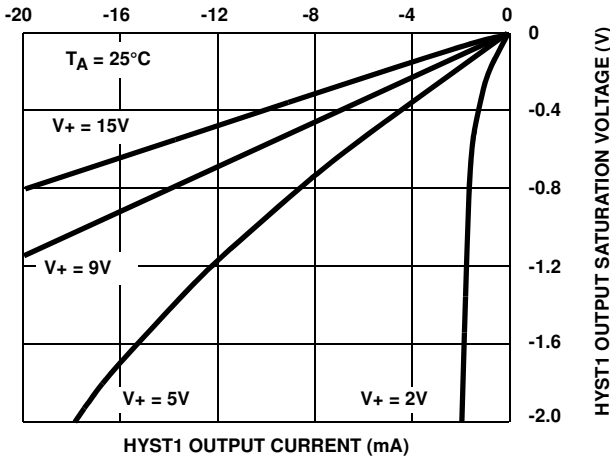

FIGURE 3. HYST1 OUTPUT SATURATION VOLTAGE vs HYST1 OUTPUT CURRENT

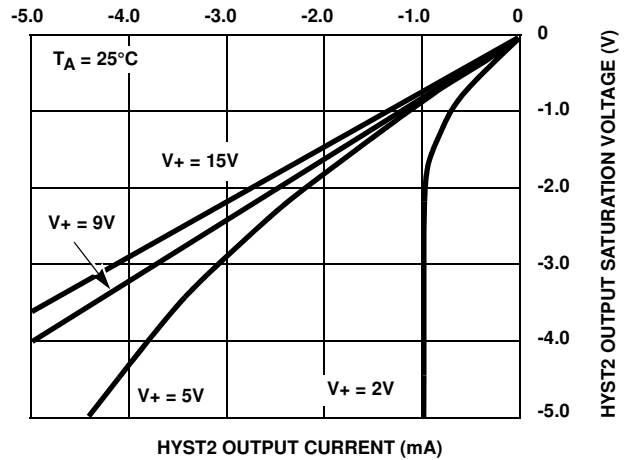

FIGURE 4. HYST2 OUTPUT SATURATION VOLTAGE vs HYST2 OUTPUT CURRENT

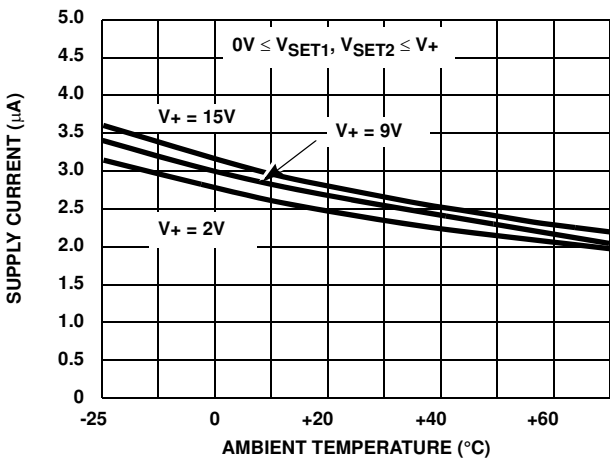

FIGURE 5. SUPPLY CURRENT AS A FUNCTION OF AMBIENT TEMPERATURE

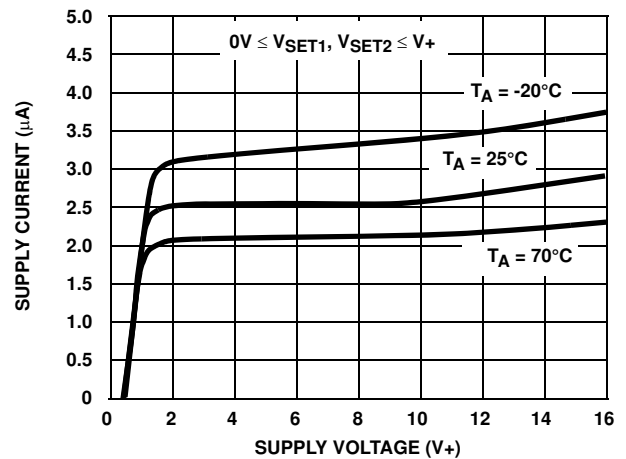

FIGURE 6. SUPPLY CURRENT AS A FUNCTION OF SUPPLY VOLTAGE

Detailed Description

As shown in the Functional Diagram, the ICL7665S consists of two comparators which compare input voltages on the SET1 and SET2 terminals to an internal 1.3V bandgap reference. The outputs from the two comparators drive open-drain N-channel transistors for OUT1 and OUT2, and open-drain P-channel transistors for HYST1 and HYST2 outputs. Each section, the Undervoltage Detector and the Overvoltage Detector, is independent of the other, although both use the internal 1.3V reference. The offset voltages of the two comparators will normally be unequal so V_{SET1} will generally not quite equal V_{SET2} .

The input impedance of the SET1 and SET2 pins are extremely high, and for most practical applications can be ignored. The four outputs are open-drain MOS transistors, and when ON behave as low resistance switches to their respective supply rails. This minimizes errors in setting up the hysteresis, and maximizes the output flexibility. The operating currents of the bandgap reference and the comparators are around 100nA each.

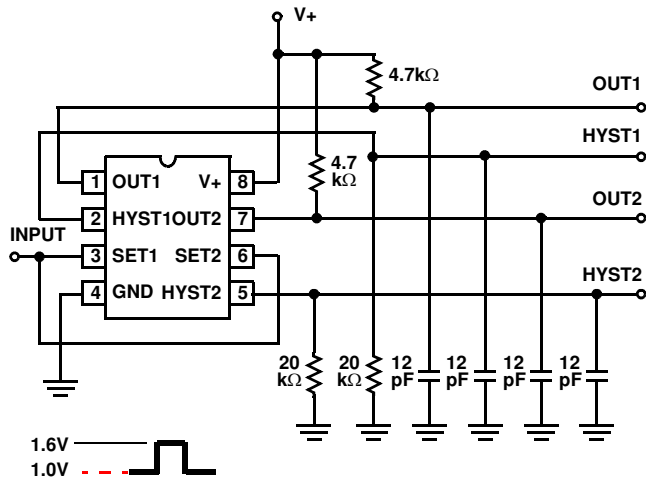

FIGURE 7. TEST CIRCUITS

Precautions

Junction isolated CMOS devices like the ICL7665S have an inherent SCR or 4-layer PNP structure distributed throughout the die. Under certain circumstances, this can be triggered into a potentially destructive high current mode. This latchup can be triggered by forward-biasing an input or output with respect to the power supply, or by applying excessive supply voltages. In very low current analog circuits, such as the ICL7665S, this SCR can also be triggered by applying the input power supply extremely rapidly (“instantaneously”), e.g., through a low impedance battery and an ON/OFF switch with short lead lengths. The rate-of-rise of the supply voltage can exceed 100V/μs in such a circuit. A low impedance capacitor (e.g., 0.05μF disc ceramic) between the V+ and GND pins of the ICL7665S can be used to reduce the rate-of-rise of the supply voltage in battery applications. In line operated systems, the rate-of-rise of the supply is limited by other considerations, and is normally not a problem.

If the SET voltages must be applied before the supply voltage $V+$, the input current should be limited to less than 0.5mA by appropriate external resistors, usually required for voltage setting anyway. A similar precaution should be taken with the outputs if it is likely that they will be driven by other circuits to levels outside the supplies at any time.

Additionally, with a $V+$ supply that has ringing or drooping after power up, a false transition on the OUTx output may occur even though the resistor programmed threshold voltage is not encroached upon. This occurs as the internal bandgap circuit time constant, on the order of a microsecond is matched by the $V+$ transient. If this occurs connecting a 1μF to the SETx pin will eliminate the OUTx false transition as the additional capacitance moves the external time constant three orders of magnitude above the internal time constant.

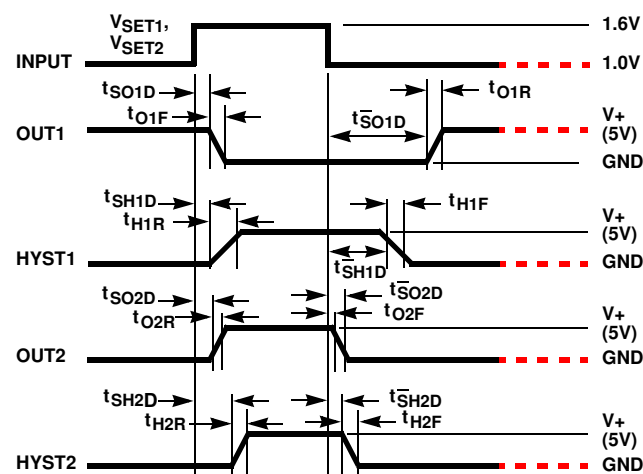

FIGURE 8. SWITCHING WAVEFORMS

Simple Threshold Detector

Figure 9 shows the simplest connection of the ICL7665S for threshold detection. From the graph 9B, it can be seen that at low input voltage OUT1 is OFF, or high, while OUT2 is ON, or low. As the input rises (e.g., at power-on) toward V_{NOM} (usually the eventual operating voltage), OUT2 goes high on reaching V_{TR2} . If the voltage rises above V_{NOM} as much as V_{TR1} , OUT1 goes low. The Equations are giving V_{SET1} and V_{SET2} are from Figure 9A:

$$V_{SET1} = V_{IN} \frac{R_{11}}{(R_{11} + R_{21})} \quad V_{SET2} = V_{IN} \frac{R_{12}}{(R_{12} + R_{22})}$$

Since the voltage to trip each comparator is nominally 1.3V, the value V_{IN} for each trip point can be found from

$$V_{TR1} = V_{SET1} \frac{(R_{11} + R_{21})}{R_{11}} = 1.3 \frac{(R_{11} + R_{21})}{R_{11}} \text{ for detector 1}$$

and

$$V_{TR2} = V_{SET2} \frac{(R_{12} + R_{22})}{R_{12}} = 1.3 \frac{(R_{12} + R_{22})}{R_{12}} \text{ for detector 2}$$

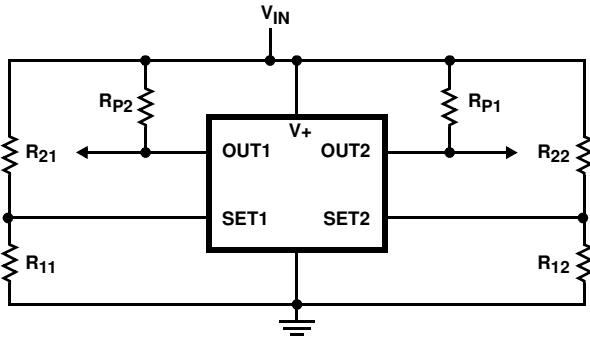

FIGURE 9A. CIRCUIT CONFIGURATION

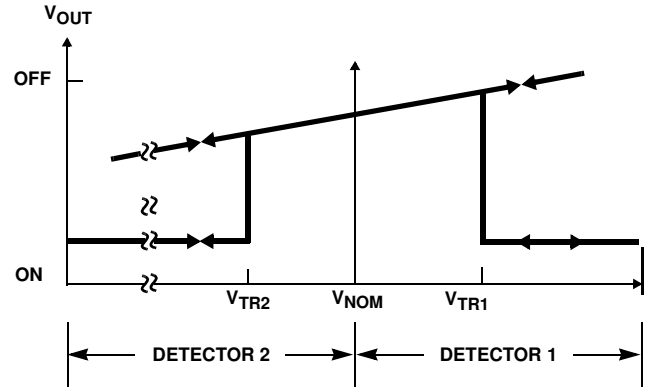

FIGURE 9B. TRANSFER CHARACTERISTICS

FIGURE 9. SIMPLE THRESHOLD DETECTOR

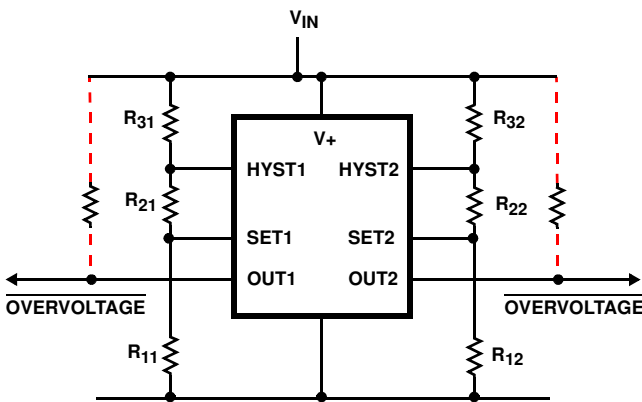

FIGURE 10A. CIRCUIT CONFIGURATION

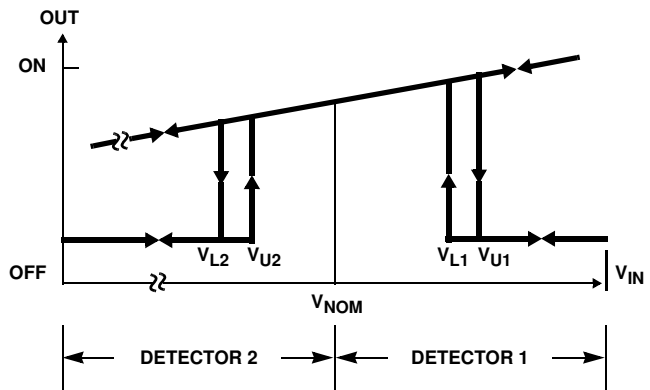

FIGURE 10B. TRANSFER CHARACTERISTICS

FIGURE 10. THRESHOLD DETECTOR WITH HYSTERESIS

Either detector may be used alone, as well as both together, in any of the circuits shown here.

When V_{IN} is very close to one of the trip voltage, normal variations and noise may cause it to wander back and forth across this level, leading to erratic output ON and OFF conditions. The addition of hysteresis, making the trip points slightly different for rising and falling inputs, will avoid this condition.

Threshold Detector with Hysteresis

Figure 10A shows how to set up such hysteresis, while Figure 10B shows how the hysteresis around each trip point produces switching action at different points depending on whether V_{IN} is rising or falling (the arrows indicated direction of change). The HYST outputs are basically switches which short out R_{31} or R_{32} when V_{IN} is above the respective trip point. Thus if the input voltage rises from a low value, the trip point will be controlled by R_{1N} , R_{2N} , and R_{3N} , until the trip point is reached. As this value is passed, the detector changes state, R_{3N} is shorted out, and the trip point

becomes controlled by only R_{1N} and R_{2N} , a lower value. The input will then have to fall to this new point to restore the initial comparator state, but as soon as this occurs, the trip point will be raised again.

An alternative circuit for obtaining hysteresis is shown in Figure 11. In this configuration, the HYST pins put the extra resistor in parallel with the upper setting resistor. The values of the resistors differ, but the action is essentially the same. The governing Equations are given in Table 1. These ignore the effects of the resistance of the HYST outputs, but these can normally be neglected if the resistor values are above about 100k Ω .

$$V_{TR2} = V_{SET2} \frac{(R_{12} + R_{22})}{R_{12}} = 1.3 \frac{(R_{12} + R_{22})}{R_{12}} \text{ for detector 2}$$

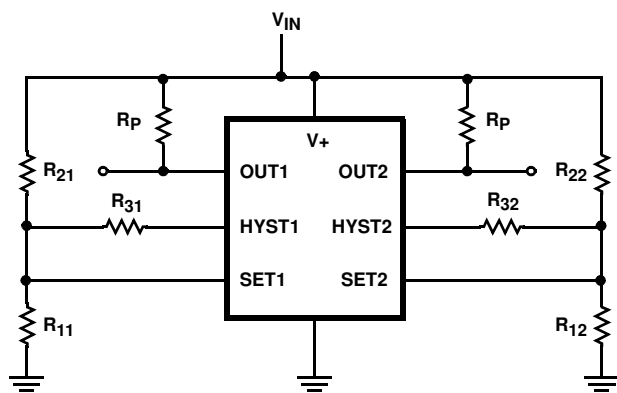

FIGURE 11. AN ALTERNATIVE HYSTERESIS CIRCUIT

TABLE 1. SET-POINT EQUATIONS

NO HYSTERESIS	
Overvoltage V_{TRIP}	$= \frac{R_{11} + R_{21}}{R_{11}} \times V_{SET1}$
Overvoltage V_{TRIP}	$= \frac{R_{12} + R_{22}}{R_{12}} \times V_{SET2}$
HYSTERESIS PER FIGURE 10A	
V_{U1}	$= \frac{R_{11} + R_{21} + R_{31}}{R_{11}} \times V_{SET1}$
Overvoltage V_{TRIP}	
V_{L1}	$= \frac{R_{11} + R_{21}}{R_{11}} \times V_{SET1}$
V_{U2}	$= \frac{R_{12} + R_{22} + R_{32}}{R_{12}} \times V_{SET2}$
Undervoltage V_{TRIP}	
V_{L2}	$= \frac{R_{12} + R_{22}}{R_{12}} \times V_{SET2}$
HYSTERESIS PER FIGURE 11	
V_{U1}	$= \frac{R_{11} + R_{21}}{R_{11}} \times V_{SET1}$
Overvoltage V_{TRIP}	
V_{L1}	$= \frac{R_{11} + \frac{R_{21}R_{31}}{R_{21} + R_{31}}}{R_{11}} \times V_{SET1}$
V_{U2}	$= \frac{R_{12} + R_{22}}{R_{12}} \times V_{SET2}$
Overvoltage V_{TRIP}	
V_{L2}	$= \frac{R_{12} + \frac{R_{22}R_{32}}{R_{22} + R_{32}}}{R_{12}} \times V_{SET2}$

Applications

Single Supply Fault Monitor

Figure 12 shows an over/under voltage fault monitor for a single supply. The overvoltage trip point is centered around 5.5V and the undervoltage trip point is centered around 4.5V. Both have some hysteresis to prevent erratic output ON and OFF conditions. The two outputs are connected in a wired OR configuration with a pull-up resistor to generate a power OK signal.

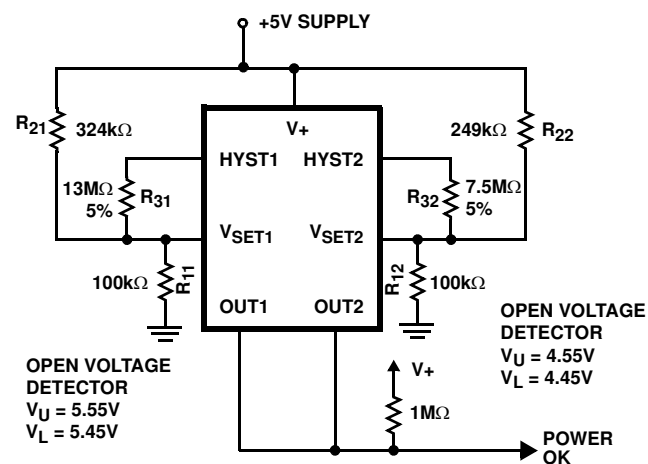

FIGURE 12. FAULT MONITOR FOR A SINGLE SUPPLY

Multiple Supply Fault Monitor

The ICL7665S can simultaneously monitor several supplies when connected as shown in Figure 13. The resistors are chosen such that the sum of the currents through R_{21A} , R_{21B} , and R_{31} is equal to the current through R_{11} when the two input voltage are at the desired low voltage detection point. The current through R_{11} at this point is equal to $1.3V/R_{11}$. The voltage at the V_{SET} input depends on the voltage of both supplies being monitored. The trip voltage of one supply while the other supply is at the nominal voltage will be different that the trip voltage when both supplies are below their nominal voltages.

The other side of the ICL7665S can be used to detect the absence of negative supplies. The trip points for OUT1 depend on both the negative supply voltages and the actual voltage of the +5V supply.

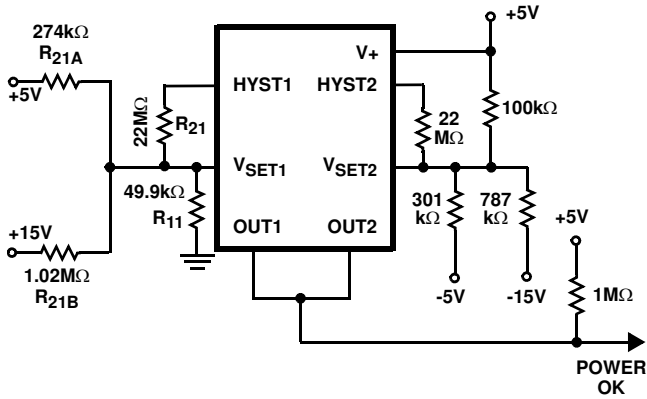

FIGURE 13. MULTIPLE SUPPLY FAULT MONITOR

Combination Low Battery Warning and Low Battery Disconnect

When using rechargeable batteries in a system, it is important to keep the batteries from being over discharged. The circuit shown in Figure 14 provides a low battery warning and also disconnects the low battery from the rest of the system to prevent damage to the battery. The OUT1 is used to shutdown the ICL7663S when the battery voltage drops to the value where the load should be disconnected.

As long as V_{SET1} is greater than 1.3V, OUT1 is low, but when V_{SET1} drops below 1.3V, OUT1 goes high shutting off the ICL7663S. The OUT2 is used for low battery warning. When V_{SET2} is greater than 1.3V, OUT2 is high and the low battery warning is on. When V_{SET2} drops below 1.3V, OUT2 is low and the low battery warning goes off. The trip voltage for low battery warning can be set higher than the trip voltage for shutdown to give advance low battery warning before the battery is disconnected.

Power Fail Warning and Power-up/Power-down Reset

Figure 14 shows a power fail warning circuit with power-up/power-down reset. When the unregulated DC input is above the trip point, OUT1 is low. When the DC input drops below the trip point, OUT1 shuts OFF and the power fail warning goes high. The voltage on the input of the 7805 will continue to provide 5V out at 1A until V_{IN} is less than 7.3V, this circuit will provide a certain amount of warning before the 5V output begins to drop.

The ICL7665S OUT2 is used to prevent a microprocessor from writing spurious data to a CMOS battery backup memory by causing OUT2 to go low when the 7805 5V output drops below the ICL7665S trip point.

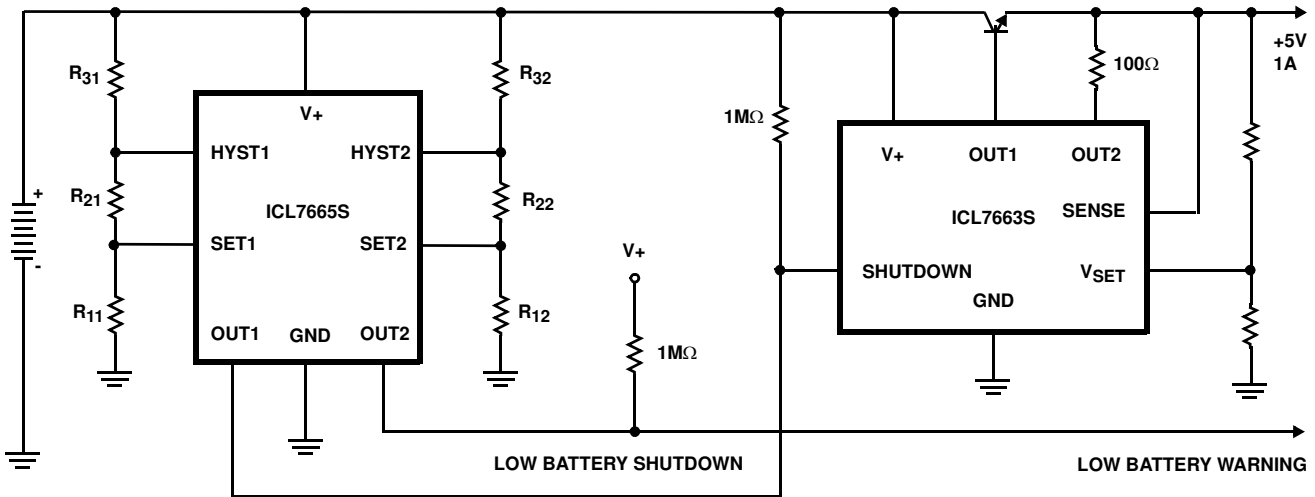

FIGURE 14. LOW BATTERY WARNING AND LOW BATTERY DISCONNECT

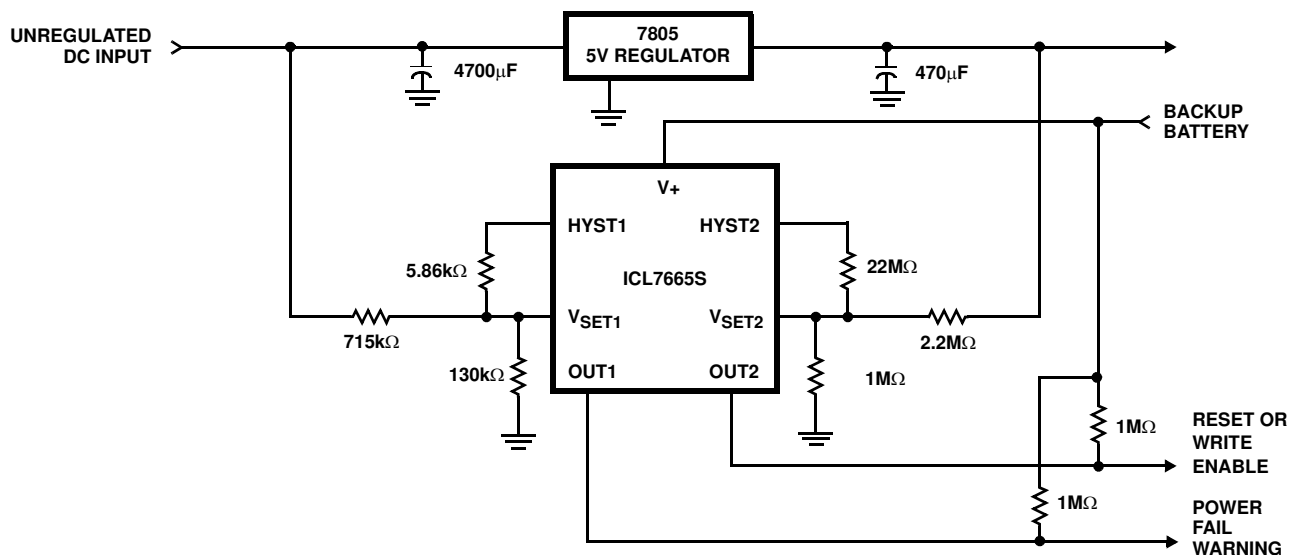

FIGURE 15. POWER FAIL WARNING AND POWERUP/POWERDOWN RESET

Simple High/Low Temperature Alarm

Figure 16 illustrates a simple high/low temperature alarm which uses the ICL7665S with an NPN transistor. The voltage at the top of R_1 is determined by the V_{BE} of the transistor and the position of R_1 's wiper arm. This voltage has a negative temperature coefficient. R_1 is adjusted so that V_{SET2} equals 1.3V when the NPN transistor's temperature reaches the temperature selected for the high temperature alarm. When this occurs, OUT2 goes low. R_2 is adjusted so that V_{SET1} equals 1.3V when the NPN transistor's temperature reaches the temperature selected for the low temperature alarm. When the temperature drops below this limit, OUT1 goes low.

AC Power Fail and Brownout Detector

Figure 17 shows a circuit that detects AC undervoltage by monitoring the secondary side of the transformer. The capacitor, C_1 , is charged through R_1 when OUT1 is OFF. With a normal 100 VAC input to the transformer, OUT1 will discharge C_1 once every cycle, approximately every 16.7ms. When the AC input voltage is reduced, OUT1 will stay OFF, so that C_1 does not discharge. When the voltage on C_1 reaches 1.3V, OUT2 turns OFF and the power fail warning goes high. The time constant, R_1C_1 , is chosen such that it takes longer than 16.7ms to charge C_1 1.3V.

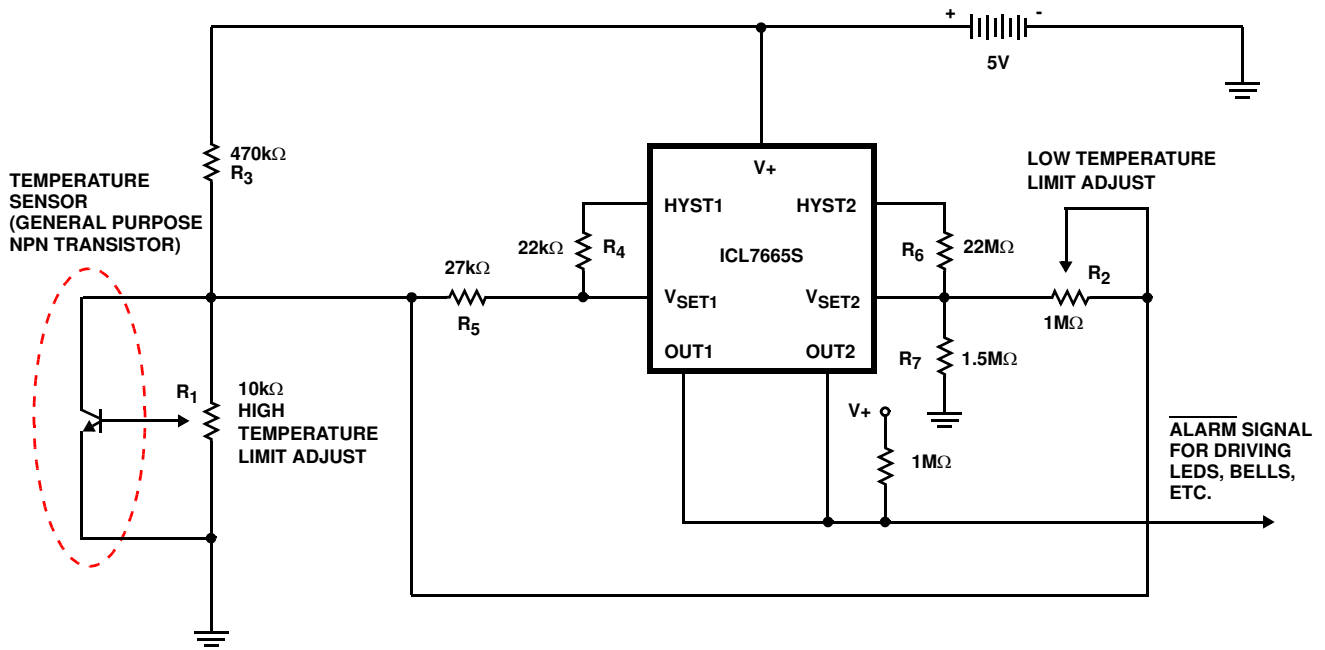

FIGURE 16. SIMPLE HIGH/LOW TEMPERATURE ALARM

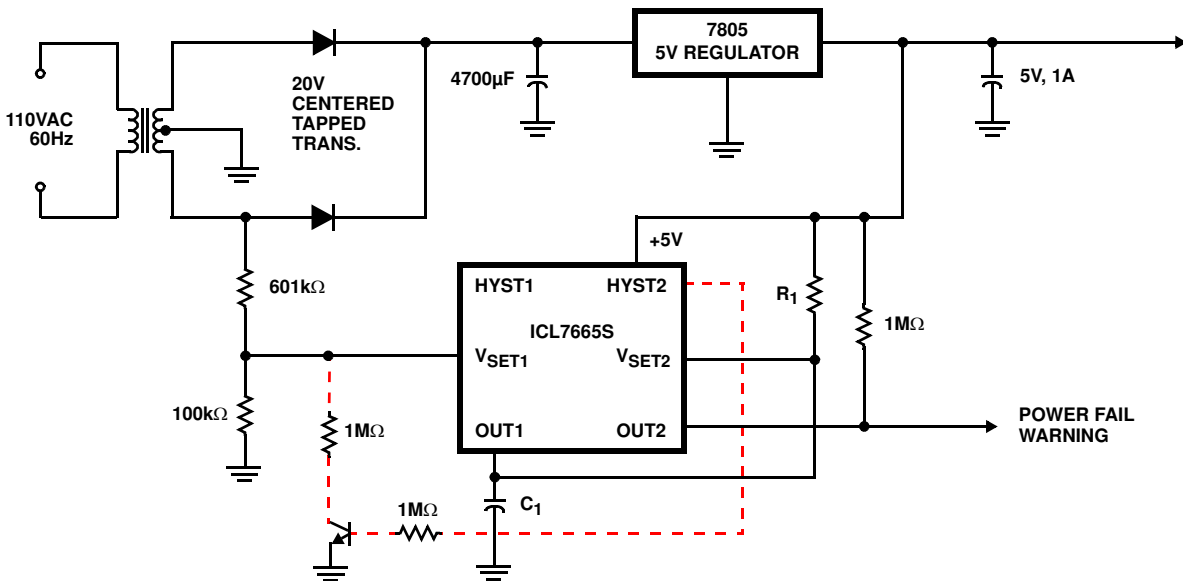

FIGURE 17. AC POWER FAIL AND BROWNOUT DETECTOR

For additional products, see www.intersil.com/en/products.html

Intersil products are manufactured, assembled and tested utilizing ISO9000 quality systems as noted in the quality certifications found at www.intersil.com/en/support/qualandreliability.html

Intersil products are sold by description only. Intersil Corporation reserves the right to make changes in circuit design, software and/or specifications at any time without notice. Accordingly, the reader is cautioned to verify that data sheets are current before placing orders. Information furnished by Intersil is believed to be accurate and reliable. However, no responsibility is assumed by Intersil or its subsidiaries for its use; nor for any infringements of patents or other rights of third parties which may result from its use. No license is granted by implication or otherwise under any patent or patent rights of Intersil or its subsidiaries.

For information regarding Intersil Corporation and its products, see www.intersil.com

Dual-In-Line Plastic Packages (PDIP)

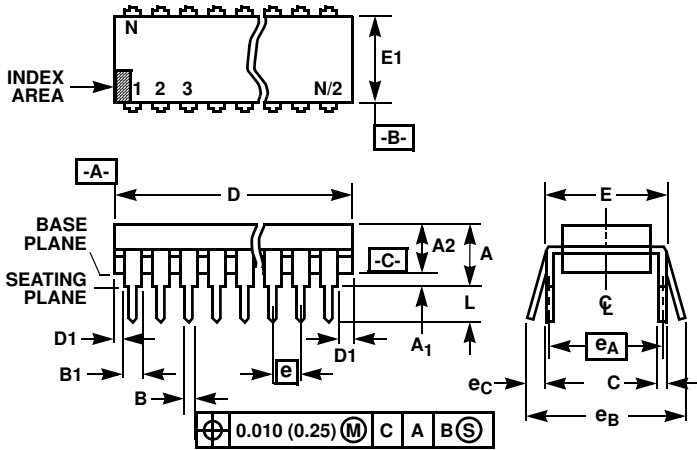

NOTES:

1. Controlling Dimensions: INCH. In case of conflict between English and Metric dimensions, the inch dimensions control.
2. Dimensioning and tolerancing per ANSI Y14.5M-1982.
3. Symbols are defined in the "MO Series Symbol List" in Section 2.2 of Publication No. 95.
4. Dimensions A, A1 and L are measured with the package seated in JEDEC seating plane gauge GS-3.
5. D, D1, and E1 dimensions do not include mold flash or protrusions. Mold flash or protrusions shall not exceed 0.010 inch (0.25mm).
6. E and e_A are measured with the leads constrained to be perpendicular to datum $-C-$.
7. e_B and e_C are measured at the lead tips with the leads unconstrained. e_C must be zero or greater.
8. B1 maximum dimensions do not include dambar protrusions. Dambar protrusions shall not exceed 0.010 inch (0.25mm).
9. N is the maximum number of terminal positions.
10. Corner leads (1, N, N/2 and N/2 + 1) for E8.3, E16.3, E18.3, E28.3, E42.6 will have a B1 dimension of 0.030 - 0.045 inch (0.76 - 1.14mm).

E8.3 (JEDEC MS-001-BA ISSUE D)
8 LEAD DUAL-IN-LINE PLASTIC PACKAGE

SYMBOL	INCHES		MILLIMETERS		NOTES
	MIN	MAX	MIN	MAX	
A	-	0.210	-	5.33	4
A1	0.015	-	0.39	-	4
A2	0.115	0.195	2.93	4.95	-
B	0.014	0.022	0.356	0.558	-
B1	0.045	0.070	1.15	1.77	8, 10
C	0.008	0.014	0.204	0.355	-
D	0.355	0.400	9.01	10.16	5
D1	0.005	-	0.13	-	5
E	0.300	0.325	7.62	8.25	6
E1	0.240	0.280	6.10	7.11	5
e	0.100 BSC		2.54 BSC		-
e_A	0.300 BSC		7.62 BSC		6
e_B	-	0.430	-	10.92	7
L	0.115	0.150	2.93	3.81	4
N	8		8		9

Rev. 0 12/93

Package Outline Drawing

M8.15

8 LEAD NARROW BODY SMALL OUTLINE PLASTIC PACKAGE

Rev 4, 1/12

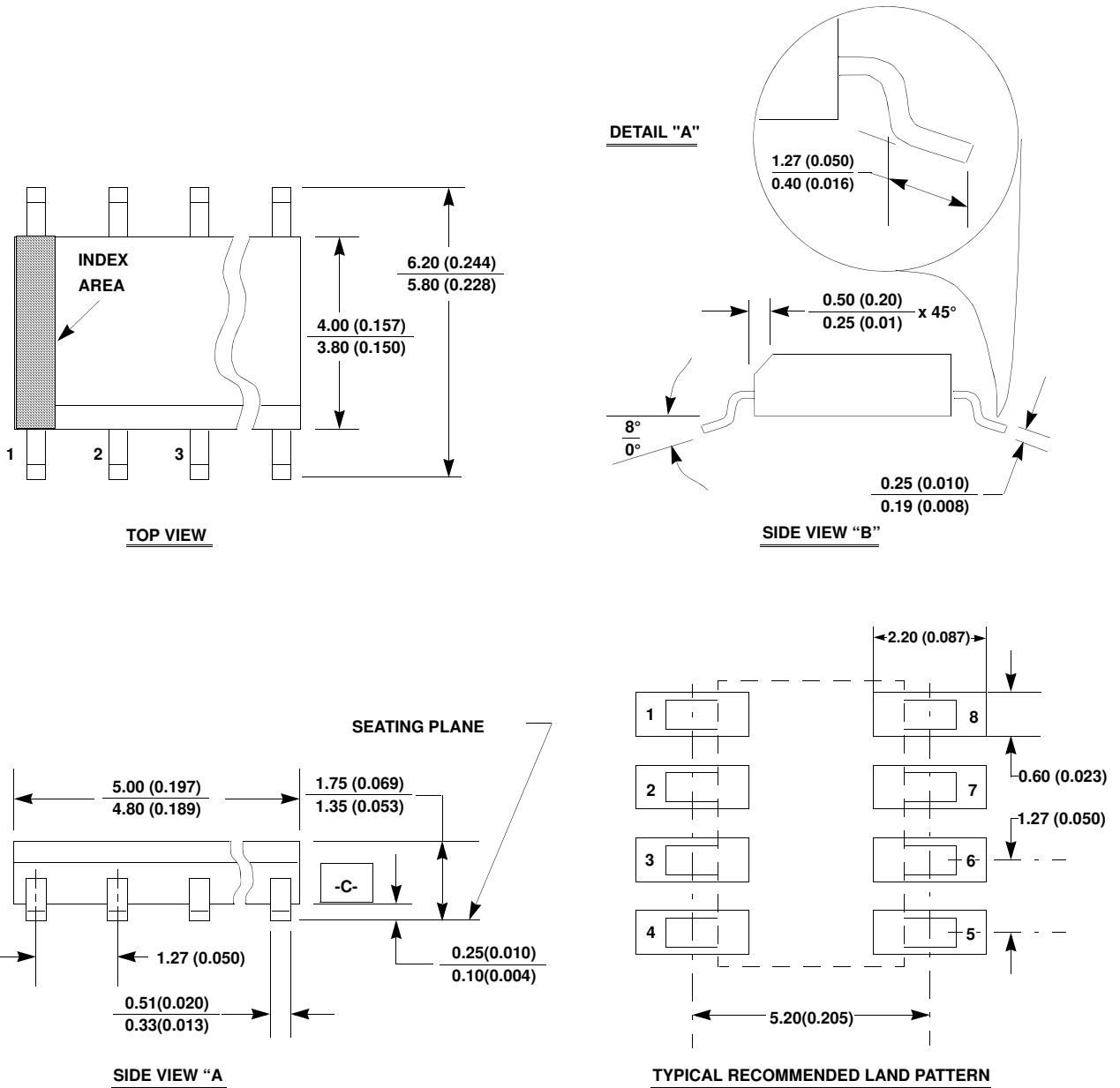

NOTES:

1. Dimensioning and tolerancing per ANSI Y14.5M-1994.
2. Package length does not include mold flash, protrusions or gate burrs. Mold flash, protrusion and gate burrs shall not exceed 0.15mm (0.006 inch) per side.
3. Package width does not include interlead flash or protrusions. Interlead flash and protrusions shall not exceed 0.25mm (0.010 inch) per side.
4. The chamfer on the body is optional. If it is not present, a visual index feature must be located within the crosshatched area.
5. Terminal numbers are shown for reference only.
6. The lead width as measured 0.36mm (0.014 inch) or greater above the seating plane, shall not exceed a maximum value of 0.61mm (0.024 inch).
7. Controlling dimension: MILLIMETER. Converted inch dimensions are not necessarily exact.
8. This outline conforms to JEDEC publication MS-012-AA ISSUE C.